



(11) **EP 2 796 764 B1**

(12) **EUROPEAN PATENT SPECIFICATION**

(45) Date of publication and mention
of the grant of the patent:
28.11.2018 Bulletin 2018/48

(51) Int Cl.:
F17C 13/00^(2006.01)

(21) Application number: **13165564.9**

(22) Date of filing: **26.04.2013**

(54) **Device for maintenance of vacuum isolated cryogenic containers**

Vorrichtung zur Wartung von vakuumisolierten Kryobehältern

Dispositif pour l'entretien des réservoirs cryogéniques isolés par vide

(84) Designated Contracting States:
**AL AT BE BG CH CY CZ DE DK EE ES FI FR GB
GR HR HU IE IS IT LI LT LU LV MC MK MT NL NO
PL PT RO RS SE SI SK SM TR**
Designated Extension States:
BA

(43) Date of publication of application:
29.10.2014 Bulletin 2014/44

(73) Proprietor: **SOL S.p.A.**
20900 Monza (IT)

(72) Inventor: **Valtolina, Daniele**
23896 Sirtori (LC) (IT)

(74) Representative: **Gislon, Gabriele**
Marietti, Gislon e Trupiano S.r.l.
Via Larga, 16
20122 Milano (IT)

(56) References cited:
CA-A1- 2 798 864 DE-A1-102007 016 974
US-A- 2 032 862 US-A- 3 364 649
US-A1- 2003 196 311

EP 2 796 764 B1

Note: Within nine months of the publication of the mention of the grant of the European patent in the European Patent Bulletin, any person may give notice to the European Patent Office of opposition to that patent, in accordance with the Implementing Regulations. Notice of opposition shall not be deemed to have been filed until the opposition fee has been paid. (Art. 99(1) European Patent Convention).

Description

[0001] The present invention relates to a device for the maintenance of cryogenic containers. Particularly, the present invention relates to an actuator device for the closing system which closes the interspace of a cryogenic container, for example of the type used for liquefied gases.

[0002] As used herein, the term "cryogenic containers" is intended to mean any structure in which a wall, generally the external one, is provided with an interspace in which a vacuum is created in order to thermally insulate the content thereof from the external environment; particularly, such a definition is intended to encompass both movable cryogenic containers of the Dewar type which are used for the transportation of liquefied gases such as oxygen and cryogenic liquefied gases in general, and fixed structures such as pipings or other structures (e.g., containers, dispensers, tanks) which either contain or are passed through by liquefied cryogenic gases.

[0003] In fact, in order to ensure a thermal insulation, it is required to extract air from the insulating interspace existing between the outer vessel and the inner vessel so as to obtain a high vacuum with pressures which may reach values even lower than $10^{-6}/10^{-7}$ Torr, thereby minimizing any conductive heat exchange. In order to create the vacuum, the interspace is provided with an opening and a closing system therefor which comprises a protruding cylindrical portion to which the pipe leading to the vacuum pump is fastened, and a member acting as a closing plug to close the opening. Typically, the time required to bring the insulating interspace from atmospheric pressure to the desired pressure is several hours, depending on the type of vacuum pump being used. The closing system for the interspace is known as a "vacuum port" in the art.

[0004] Once the desired pressure value has been reached, the opening connecting the interspace to the outside is closed with the plug, which is inserted into the protruding cylindrical portion; the plug is provided with a sealing gasket and, when the interspace is being closed, it is forced into the cylindrical portion. In the following description, this plug - housing assembly will be referred to as a "closing system for the container".

[0005] Cryogenic containers require maintenance and particularly periodic inspection and restoring the vacuum within the interspace as needed. In order to implement this procedure, the plug is removed from its housing on the container and the interspace of the container is connected to the vacuum pump, preferably without bringing the interspace to ambient pressure because of the long time required to bring it back to the requisite value of vacuum. To this aim, an actuator device (also referred to as a "gun") is used which allows the plug to be removed and repositioned and the interspace to be connected to the vacuum source without losing the residual vacuum existing within the interspace; the actuator device comprises a generally cylindrical body which is provided with

a tubular side fitting for the connection to the vacuum pump; the cylindrical body has accommodated therein a movable rod which can engage with the plug arranged on the outlet of the container interspace in order to pull it out and move it back at the end of the restoring process.

[0006] A problem with the actuators known in the art is that they are entirely made of metal, thereby preventing the user from observing the position of the plug with respect to either its housing on the container or the fitting leading to the vacuum pump; furthermore, conventional actuators prevent the user from visually checking the conditions of the sealing gasket on the plug in order to determine whether the gasket has to be replaced.

[0007] In order to solve this problem, actuators (i.e. guns) have been proposed in which the cylindrical body is made of a transparent plastic material, particularly Plexiglas, so as to allow the position of the plug and the conditions of the gasket to be checked. However, this approach has the drawback of using a material, i.e. plastic, which is partially permeable to gases and also likely to develop cracks and breaks in the device body with use.

[0008] US 3364649 discloses an apparatus for sealing vacuum enclosures, comprising a transparent glass evacuation chamber. An external gasket may be clamped onto the lower portion of the transparent chamber to allow connection with the enclosure. The transparent chamber is also provided with a duct that may be connected to a vacuum source. The shape of the transparent chamber is quite complex to realize, and shaping fittings with precision in glass is very expensive.

[0009] An alternative approach is to use a completely metal actuator which is provided with position sensors for the plug. However, this approach is expensive and still not able to solve the problem of checking the condition of the gasket which, not being visible, should be periodically inspected regardless of its condition. In turn, the periodic inspection of the gasket, and the replacement thereof even if in good condition, leads to a significantly long time to restore the container, resulting in increased costs for the maintenance process.

[0010] The aim of the present invention is to solve the above mentioned problems by providing an actuator device for closing systems for a container, being able to be sealed and allowing the gasket of the plug of the closing system to be checked, thereby reducing time and costs for the container maintenance. This aim is achieved by the present invention which provides an actuator device for closing systems for interspaces in containers for cryogenic gases, said closing system comprising a plug and a seat for said plug, wherein said actuator device comprises:

- an at least partially hollow tubular body;
- a first fitting for the connection to a closing system;
- a rod axially movable through one end of said body and whose length is sufficient to reach at least the opposite end of said body, said rod being provided with means for the engagement with said closing

plug;

- a second tubular fitting for the connection to a vacuum source, the fitting being fastened to the side of said body at said hollow portion of said body;

characterized in that said body comprises a metal portion and a transparent material portion which are sealingly constrained to each other, and in that said first and second fittings are fastened to said metal portion of said tubular body, and in that the afore mentioned end wall passed through by said rod is part of the transparent material portion of said tubular body.

[0011] According to the invention, the actuator acts on the closing system for the vacuum interspace of a cryogenic container, the closing system comprises a plug and a seat for the plug, such a seat being externally engaged by the first fitting of the actuator device. The body of the actuator device is at least partially hollow and, as known in the art, it is provided with a rod axially movable through one end of the body, i.e. through one side of the actuator device, and whose length is sufficient to reach at least the opposite end of said body, and which is provided with means for the engagement with the plug of the closing system; a second tubular fitting is also provided for the connection to a vacuum source, such a second fitting being fastened to the side of the body at said hollow part of said body.

[0012] The tubular body of the actuator device comprises a metal portion and a transparent material portion which can be sealingly constrained to each other, both the first and second fittings are advantageously fastened to the metal portion of said tubular body, whereas the mentioned end wall passed through by the rod is part of the transparent material portion of the tubular body.

[0013] In an embodiment of the invention the first fitting can be removed and/ or replaced with a different fitting.

[0014] In a further embodiment of the invention, the second fitting is a tubular pipe whose diameter is substantially equal to that of the pipe leading to said vacuum pump.

[0015] According to an embodiment of the invention, the distance between the second fitting and the end of the metal body which is adjacent to the transparent body may be such that said plug can be housed therein; in this case, the sizes, namely the internal diameter, of this part of the metal body are such that the plug can be sealingly housed within said portion so as to confine the vacuum only to the metal part of the device.

[0016] Preferably, the metal portion and the transparent portion of the tubular body are constrained to each other by reversible means, such as screws or the like, which allow for the replacement of sealing gaskets interposed therebetween.

[0017] According to a possible embodiment of the device of the invention, the device comprises a slide valve or the like to temporarily close the interspace of the container while the gasket on the plug is being replaced, thereby preventing the residual vacuum in said inter-

space from being lost.

[0018] The invention further concerns a process for the maintenance of cryogenic containers by the removal of the plug of the closing system for said container and the connection of the interspace of said container to a vacuum source, characterized by using an actuator of the afore described type for the removal of said plug, said plug being passed through a metal portion of the body of said actuator until it reaches a transparent portion of said actuator in order to allow said plug to be visually inspected.

[0019] In a preferred embodiment of the invention, the hollow part of said body extends through said metal portion of the tubular body and through part of the transparent material portion of the body, and has a size sufficient to allow said plug to be moved within said transparent part for the inspection thereof.

[0020] Further preferred embodiments are set forth in the dependent claims.

[0021] The invention presents a number of advantages relative to the known art.

[0022] In fact, the presence of a metal portion of the body to which the two fittings for the connection to both the vacuum pump and the closing system of the container are constrained, can provide a structure which is solid and impermeable to gases, without sealing problems for the fittings on the tubular body as well as without cracking problems.

[0023] Moreover, since the condition of the gasket of the plug can be visually inspected by positioning it at the transparent material portion of the body of the device, the condition of the gasket on the plug can be checked in a simple and reliable manner.

[0024] A further advantage is that the fitting for the connection to the vacuum pump can be dimensioned in such a way that the diameter of the fitting is equal or similar to that of the pipe of the pump, thereby preventing the vacuum line from being restricted.

[0025] Furthermore, the invention provides that the plug can be (at least partially) sealingly positioned within the cavity formed in the metal portion of the cylindrical body after the inspection thereof, so as to be able to confine the vacuum only to the metal part of the device during the vacuum restoring process.

[0026] Further characteristics and advantages of the present invention will be more evident from the following description, made for illustration purposes only and without limitation, with particular reference to the accompanying schematic drawings, wherein:

- Figure 1 is an overall view of the actuator device according to the embodiment of the present invention when in use;
- Figure 2 is an exploded view of the actuator device as shown in Figure 1;
- Figure 3 is a perspective view of the transparent plastic portion of the tubular body;
- Figure 4 is a longitudinal section view of the actuator

- device when closed and engaged with the container;
- Figure 5 is a longitudinal section view of the actuator device when open and engaged with the container, and
- Figure 6 is a sectional view of a further embodiment of the device during the step of restoring the vacuum.

[0027] Referring initially to Figures 1 and 2, an actuator device 11 according to the present invention is shown which comprises a knob 1, a tubular body T composed of a metal portion 7 and a transparent portion 4 generally made of a transparent plastic material such as, for example, polycarbonate or the like. As better described below, the two portions 4 and 7 of the body T are constrained to each other so as to form a sealing body T. A first axial fitting 8 and a second side tubular fitting 9, which are both made of a metal, e.g. steel, as is the portion 7 of the body T, are provided for the metal portion 7 in a way known in the art, for example by welding. The two portions 4 and 7 are internally hollow.

[0028] Specifically, with reference to Figure 2, the knob 1 is constrained to a rod 2 which can be rotated together with the knob 1 and axially moved within the portion 4 and portion 7 of the tubular body T (Figs. 4 and 5). As better shown in Figures 4 and 5, the upper end 2a of the rod 2 is housed within the knob 1, and the latter is constrained to the rod so as to allow the rod to be both rotated about its axis A-A and translationally moved therealong within the tubular body T.

[0029] The length of the rod 2 is such that it can reach at least the opposite end of the metal portion 7 of the tubular body T; in such a way, the lower end 2b of the rod 2, which is threaded, can be engaged with a corresponding internal thread (not shown) formed in the sealing plug 13 of the container (Figs. 4-5) through a rotational movement of the knob 1.

[0030] With reference to Figure 3, there is shown in detail the portion 4 which is made of a transparent material, generally a plastic such as polycarbonate; such a portion is provided with an internal cylindrical cavity C1 having size sufficient to freely accommodate the plug 13 of the container when the gasket 16 thereof is being visually inspected. The cavity C1 defines a wall 4a. The rod 2 is sealingly slidable within a hole 4c obtained through the wall 4a of the portion 4 of the body T and the seal between the rod 2 and the wall of the hole 4c is made by means of one or more gaskets; in the embodiment shown herein, there are three gaskets 3 of O-ring type which are identical in size and housed within three grooves 17 intended to accommodate them.

[0031] In order to constrain the two portions 4 and 7 of the tubular body T to each other, the wall 4a of the portion 4 is provided with four fastening holes 12 at the corners, said holes being intended to accommodate constraining means, such as sealing screws or the like (not shown), in order to fasten the transparent portion 4 to the metal portion 7.

[0032] Since the portion 4 is made of a transparent

material, it enables the position of the sealing plug 13 (Fig. 5) to be checked directly once it has been removed from the container 15, and to determine whether the sealing gasket 16 accommodated therein, generally of an O-ring type, has to be replaced due to wear.

[0033] The plug 13 provided with the sealing gasket 16 is usually positioned in a known way (Fig. 4) within the seat 14 acting as a connector to the interspace of the container 15, which is under a high vacuum. The plug 13 is provided with means, such as an internal thread, adapted to be engaged by the end of the rod 2 in a known manner. Furthermore, from Figures 4 and 5, it can be noted that a cylindrical-shaped step protrudes from the lower surface of the portion 4 for the engagement with a corresponding step formed in the front part of the portion 7.

[0034] With reference to Figure 2, the metal portion 7 has an internal cylindrical-shaped cavity C2 whose size is equal to that of the cavity C1 and in any case sufficient to allow the plug 13 to be passed therethrough before the inspection and then housed therein after the inspection. Two grooves or housings 7b are obtained in the upper surface 7a of the portion 7 in order to accommodate the gaskets 5-6 which provide the seal between the two portions of the tubular body T.

[0035] In one embodiment, the gaskets 5-6 have two different diameters which are equal to those of the corresponding grooves 7b in which the gaskets are housed, thereby providing a seal between the portion 7 and the protruding step of the portion 4.

[0036] Moreover, in order to constrain the portion 4 to the portion 7 there are four holes 7c arranged at the corners of the surface 7a and next to the holes 12 which are intended to accommodate the reversible means (not shown) already partially housed within the holes 12 of the portion 4.

[0037] The lower surface of the portion 7 has welded thereto an annular nut 7d for the engagement with the cylindrical-shaped sealing fitting 8 (Fig. 2) with the aid of a pair of sealing gaskets 6a, usually of an O-ring type; the gaskets 6a may be identical in diameter to the gasket 6.

[0038] As shown in Figures 4-5, the sealing fitting 8 is required to ensure the engagement of the actuator device 11 with the closing system of the container 15.

[0039] Such a closing system comprises (Figs. 4-5) a sealing plug 13 and a cylindrical-shaped seat 14 intended to house the sealing plug 13; the seat 14 also acts as a connector to which the "gun", i.e. the actuator device according to the invention, is mounted. The plug 13 is characterized by an internal thread (not shown) intended to be engaged with the end 2b of the rod 2 (Fig. 2) and it is externally provided with a sealing gasket 16, for example of an O-ring type.

[0040] Once the lower end 2b of the rod 2 has been engaged with the corresponding internal thread formed in the sealing plug 13 through the rotational movement of the knob 1 (Fig. 4), the plug is slid through the cavity

C2 and along the axis A-A until it reaches the cavity C1 (Fig. 5), where the visual inspection occurs.

[0041] As shown in Figures 4-5, the sealing fitting 8 is internally engaged with the seat 14 of the sealing plug 13 of the cryogenic container 15. Furthermore, the fitting 8 can be removed and/ or replaced with another fitting which is similar in shape but different in size according to the diameter required for the outlet to properly engage with the seat 14 of the plug.

[0042] One of the side surfaces of the metal portion 7 (Figs. 1-2) has welded thereto a side tubular fitting 9 made of steel for the connection to the vacuum pump (not shown). The fitting 9 is a tubular pipe whose diameter is substantially equal to that of the hose of the pump (not shown), thereby preventing the operation of the pump from being restricted.

[0043] In the embodiment shown in Figures 4-5, the fitting 9 is welded to the portion 7 in such a way that the axis of the fitting 9 forms an angle in the range from 35 to 55°, more preferably of about 45°, with the axis A-A of the tubular body (which is coaxial with the rod 2). The fitting 9 is welded at the cavity C2 of the metal part 7 of the tubular body T.

[0044] The free end of the fitting 9, which is directed towards the pump, has a steel flange 10 to facilitate the connection and release of the device to/ from the pump, for example in order to clean the device 11.

[0045] The embodiment illustrated in Fig. 6 shows an embodiment of a device in which the distance between the weld root 18 of the fitting 9 and the upper surface 7a of the portion 7 (i.e. the surface of portion 7 in contact with the transparent part 4) is such that there is a sufficient space to sealingly house the plug 13 therein after the inspection. In other words, the portion of the metal body 7 which is adjacent to the transparent body 4, is shaped in such a way as to be able to sealingly house the plug; therefore, the plug can take an intermediate position between the position in which the "vacuum port" of the interspace 15 is closed, and the position in which it is fully retracted into the transparent part 4 in order to allow the plug to be visually inspected. The intermediate position shown in Fig. 6, in which the plug is sealed against the body 7, allows the vacuum to be confined to the metal part 7 of the body T. More in detail, the metal portion 7 of the tubular body is provided with a part 17 in which the cavity C2 has a diameter which is reduced with respect to the diameter of the remainder of the cavity C2 and which can be substantially equal to the diameter of the seat 14 of the closing system for the container, such a reduced diameter being in any case sufficient to provide a sufficient seal between the plug and the part 17 of the body 7. In this way, when the plug 13 is positioned in the area defined by the portions 17 of the body 7, as shown in Fig. 6, said plug is sealed thereagainst preferably as if it were in the seat 14, thereby preventing the plastic part 4 of the tubular body T from being stressed by the high vacuum created by the pump.

[0046] Finally, in a further variant embodiment of the

invention, a slide valve (not shown) may be interposed either between the device and the closing system for the interspace of the container 15 or between two portions of the actuator device, for example between the portions 4 and 7 of the body T. In this case, the two portions should be releasable in order to allow the plug to be removed and the gasket to be replaced. When the gasket 16 in the plug 13 of the closing system of the container 15 has to be replaced, the valve is closed so as to allow the interspace of the container 15 to be maintained under vacuum, thereby avoiding the need to remove the residual vacuum in order to carry out the replacement of the gasket.

[0047] When in operation, the device 11 is initially positioned with the fitting 8 which houses the seat 14 of the closing system for the container 15 and the second fitting which is connected to the vacuum source. Once the device is under vacuum, the rod 2 is translated until it reaches the plug 13; at this time, the rod 2 is engaged with the plug, for example, in the embodiment shown herein, the rod 2 is rotated by the knob 1 in order to screw the end of the rod into the threaded seat formed in the plug 13. As mentioned above, the cavities C1 and C2 are under vacuum.

[0048] Once the plug 13 has been engaged by the rod 2, the rod 2 is moved back to the starting position, i.e. partially extracted from the body T, while the plug 13 is simultaneously removed from the seat 14 and moved until it reaches the cavity C1 in the transparent portion 4 of the tubular body T, adjacent to the wall 4a, as shown in Fig. 5. Then, the plug is inspected to check the condition of the gasket 16 and, if necessary, the gasket is replaced with a new one. Thereafter, the vacuum required in the interspace is restored. In case of use of a device as that shown in Fig. 6, the plug 13 is advantageously moved to the intermediate position between the two above described positions as shown in Fig. 6, where the plug is sealingly housed within the portion 17 of the metal body 7.

[0049] At the end of the vacuum restoring process, the plug is moved back to its starting position within the seat 14. Then, the gun 11 is removed from the container.

45 Claims

1. Actuator device (11) for closing systems for a cryogenic container (15), comprising:

- an at least partially hollow tubular body (T);
- a first fitting (8) for the connection to a closing system, said system comprising a plug (13) and a seat (14) for said plug;
- a rod (2) axially movable through one end wall (4a) of said body (T) and whose length is sufficient to reach at least the opposite end of said body (T), said rod (2) being provided with means for the engagement with said closing plug (13);

- a second tubular fitting (9) for the connection to a vacuum source, said second fitting being fastened to the side of said body (T) at said hollow portion of said body;

characterized in that said tubular body (T) comprises a metal portion (7) and a transparent material portion (4) which are sealingly constrained to each other, **in that** said first fitting (8) and said second fitting (9) are fastened to said metal portion (7) of said tubular body (T), and **in that** said end wall passed through by said rod (2) is part of the transparent material portion (4) of said tubular body (T).

2. Actuator (11) according to claim 1, wherein the hollow part of said body extends through said metal portion (7) of the tubular body (T) and through part of the transparent material portion (4) of the body and has a size sufficient to allow said plug (13) to be passed therethrough until it reaches said transparent portion (4).
3. Actuator (11) according to claim 1 or 2, wherein said first fitting (8) can be removed and/ or replaced with a different fitting.
4. Actuator (11) according to any one of the preceding claims, wherein said second fitting (9) is a tubular pipe whose diameter is substantially equal to that of a pipe leading to said vacuum pump.
5. Actuator (11) according to any one of the preceding claims, wherein the distance between said second fitting (9) and the end of the metal body (7) which is adjacent to the transparent body (4) is such that at least part of said plug (13) can be housed therein.
6. Actuator (11) according to claim 5, wherein said portion (7) of the tubular body (T) is provided with a part (17) in which the cavity (C2) of the metal body has a reduced diameter in order to provide a seal between the plug (13) and said part (17) of the body (7).
7. Actuator (11) according to any one of the preceding claims, wherein said metal portion (7) and said transparent portion (4) of the tubular body (T) are constrained to each other by reversible means such as screws or the like.
8. Process for the maintenance of a cryogenic container by the removal of the plug (13) of a closing system for said container and the connection of the interspace of said container to a vacuum source, **characterized by** using an actuator (11) according to any one of the preceding claims for the removal of said plug (13), said plug (13) being passed through the metal portion (7) of the body (T) of said actuator (11) until it reaches the transparent portion (4) of said

actuator (11) in order to allow said plug (13) to be visually inspected.

9. Process according to claim 8 wherein, after said plug (13) has been inspected, it is at least partially moved into the cavity (C2) formed in said metal portion (7) of the cylindrical body (T) and sealingly housed between the walls of said cavity (C2) during the step of vacuum restoring .

Patentansprüche

1. Stelleinrichtung (11) für Verschlussysteme für einen kryogenen Behälter (15), umfassend:
 - einen zumindest teilweise hohlen röhrenförmigen Körper (T);
 - einen ersten Anschluss (8) für die Verbindung mit einem Verschlussystem, wobei das System einen Stopfen (13) und einen Sitz (14) für den Stopfen umfasst;
 - eine Stange (2), die axial durch eine Stirnwand (4a) des Körpers (T) bewegbar ist und deren Länge ausreicht, um mindestens das gegenüberliegende Ende des Körpers (T) zu erreichen, wobei die Stange (2) mit Mitteln zum Eingriff mit dem Verschlussstopfen (13) versehen ist;
 - einen zweiten röhrenförmigen Anschlussstutzen (9) zur Verbindung mit einer Vakuumquelle, wobei der zweite Anschlussstutzen an der Seite des Körpers (T) an dem hohlen Abschnitt des Körpers befestigt ist;

dadurch gekennzeichnet, dass der röhrenförmige Körper (T) einen Metallabschnitt (7) und einen Abschnitt aus transparentem Material (4) umfasst, die abdichtend miteinander verbunden sind, indem der erste Anschlussstutzen (8) und der zweite Anschlussstutzen (9) an dem Metallabschnitt (7) des röhrenförmigen Körpers (T) befestigt sind, und dadurch, dass die Stirnwand, durch die die Stange (2) hindurchgeführt wird, Teil des Abschnitts aus transparentem Material (4) des röhrenförmigen Körpers (T) ist.
2. Stelleinrichtung (11) gemäß Anspruch 1, wobei sich der hohle Abschnitt des Körpers durch den Metallabschnitt (7) des röhrenförmigen Körpers (T) und durch einen Teil des Abschnitts aus transparentem Material (4) des Körpers erstreckt und eine ausreichende Größe aufweist, um zu ermöglichen, dass der Stopfen (13) hindurchgeführt wird, bis er den transparenten Abschnitt (4) erreicht.
3. Stelleinrichtung (11) gemäß Anspruch 1 oder 2, wobei der erste Anschlussstutzen (8) entfernt und/oder durch einen anderen Anschlussstutzen ersetzt wer-

den kann.

4. Stelleinrichtung (11) gemäß irgendeinem der vorhergehenden Ansprüche, wobei das zweite Anschlussstück (9) eine röhrenförmige Leitung ist, deren Durchmesser im Wesentlichen gleich dem eines Rohrs ist, das zu der Vakuumpumpe führt. 5
5. Stelleinrichtung (11) gemäß irgendeinem der vorhergehenden Ansprüche, wobei der Abstand zwischen dem zweiten Anschlussstutzen (9) und dem Ende des Metallgehäuses (7), das an den transparenten Körper (4) angrenzt, derart ist, dass zumindest ein Teil des Stopfens (13) darin untergebracht sein kann. 10
6. Stelleinrichtung (11) gemäß Anspruch 5, wobei der Abschnitt (7) des röhrenförmigen Körpers (T) mit einem Teil (17) versehen ist, in dem der Hohlraum (C2) des Metallgehäuses einen verringerten Durchmesser aufweist, um eine Dichtung zwischen dem Stopfen (13) und dem Teil (17) des Körpers (7) bereitzustellen. 15
7. Stelleinrichtung (11) gemäß irgendeinem der vorhergehenden Ansprüche, wobei der Metallabschnitt (7) und der transparente Abschnitt (4) des röhrenförmigen Körpers (T) durch reversible Mittel wie Schrauben oder dergleichen miteinander verbunden sind. 20
8. Verfahren zur Wartung eines kryogenen Behälters durch Entfernen des Stopfens (13) eines Verschlussystems für den Behälter und die Verbindung des Zwischenraumes des Behälters mit einer Vakuumquelle, **gekennzeichnet durch** Verwendung einer Stelleinrichtung (11) gemäß irgendeinem der vorhergehenden Ansprüche zum Entfernen des Stopfens (13), wobei der Stopfen (13) durch einen Metallabschnitt (7) des Körpers (T) der Stelleinrichtung (11) geführt wird, bis er den transparenten Abschnitt (4) der Stelleinrichtung (11) erreicht, um zu ermöglichen, dass der Stopfen (13) visuell überprüft wird. 25
9. Verfahren gemäß Anspruch 8, bei dem, nachdem der Stopfen (13) überprüft worden ist, dieser zumindest teilweise in den Hohlraum (C2) bewegt wird, der in dem Metallabschnitt (7) des zylindrischen Körpers (T) ausgebildet ist und während des Schritts der Vakuumwiederherstellung abdichtend zwischen den Wänden des Hohlraums (C2) aufgenommen wird. 30

Revendications 35

1. Dispositif actionneur (11) pour des systèmes de fermeture pour un conteneur cryogénique (15),

comprenant :

- un corps tubulaire au moins partiellement creux (T) ;
- un premier raccord (8) pour la connexion à un système de fermeture, ledit système comprenant un bouchon (13) et un siège (14) pour ledit bouchon ;
- une tige (2) mobile de façon axiale à travers une paroi d'extrémité (4a) dudit corps (T) et dont la longueur est suffisante pour atteindre au moins l'extrémité opposée dudit corps (T), ladite tige (2) étant munie d'un moyen pour la mise en prise avec ledit bouchon de fermeture (13) ;
- un second raccord tubulaire (9) pour la connexion à une source de vide, ledit second raccord étant fixé au côté dudit corps (T) au niveau de ladite portion creuse dudit corps ;

caractérisé en ce que ledit corps tubulaire (T) comprend une portion de métal (7) et une portion de matière transparente (4) qui sont contraintes l'une à l'autre de manière étanche, **en ce que** ledit premier raccord (8) et ledit second raccord (9) sont attachés à ladite portion de métal (7) dudit corps tubulaire (T), et **en ce que** ladite paroi d'extrémité à travers laquelle ladite tige passe (2) fait partie de la portion de matière transparente (4) dudit corps tubulaire (T). 20

2. Actionneur (11) selon la revendication 1, dans lequel la partie creuse dudit corps s'étend à travers ladite portion de métal (7) du corps tubulaire (T) et à travers une partie de la portion de matière transparente (4) du corps et a une taille suffisante pour permettre audit bouchon (13) d'être traversé par cette dernière jusqu'à ce qu'il atteigne ladite portion transparente (4). 25
3. Actionneur (11) selon la revendication 1 ou 2, dans lequel ledit premier raccord (8) peut être enlevé et/ou remplacé par un raccord différent. 30
4. Actionneur (11) selon l'une quelconque des revendications précédentes, dans lequel ledit second raccord (9) est un tuyau tubulaire dont le diamètre est sensiblement égal à celui d'un tuyau menant à ladite pompe à vide. 35
5. Actionneur (11) selon l'une quelconque des revendications précédentes, dans lequel la distance entre ledit second raccord (9) et l'extrémité du corps de métal (7) qui est adjacente au corps transparent (4) est telle qu'au moins une partie dudit bouchon (13) peut être logée en son sein. 40
6. Actionneur (11) selon la revendication 5, dans lequel ladite portion (7) du corps tubulaire (T) est munie d'une partie (17) dans laquelle la cavité (C2) du corps 45

de métal a un diamètre réduit afin de définir un joint entre le bouchon (13) et ladite partie (17) du corps (7).

7. Actionneur (11) selon l'une quelconque des revendications précédentes, dans lequel ladite portion de métal (7) et ladite portion transparente (4) du corps tubulaire (T) sont contraintes l'une à l'autre par un moyen réversible comme des vis ou analogues. 5
10
8. Processus pour la maintenance d'un conteneur cryogénique par l'enlèvement du bouchon (13) d'un système de fermeture pour ledit conteneur et la connexion de l'inter-espace dudit conteneur à une source de vide, **caractérisé par** l'utilisation d'un actionneur (11) selon l'une quelconque des revendications précédentes pour l'enlèvement dudit bouchon (13), ledit bouchon (13) étant passé à travers la portion de métal (7) du corps (T) dudit actionneur (11) jusqu'à ce qu'il atteigne la portion transparente (4) dudit actionneur (11) afin de permettre audit bouchon (13) d'être visuellement inspecté. 15
20
9. Processus selon la revendication 8 dans lequel, après que ledit bouchon (13) a été inspecté, il est au moins partiellement déplacé dans la cavité (C2) formée dans ladite portion de métal (7) du corps cylindrique (T) et logé de manière étanche entre les parois de ladite cavité (C2) pendant l'étape de rétablissement de vide. 25
30

35

40

45

50

55

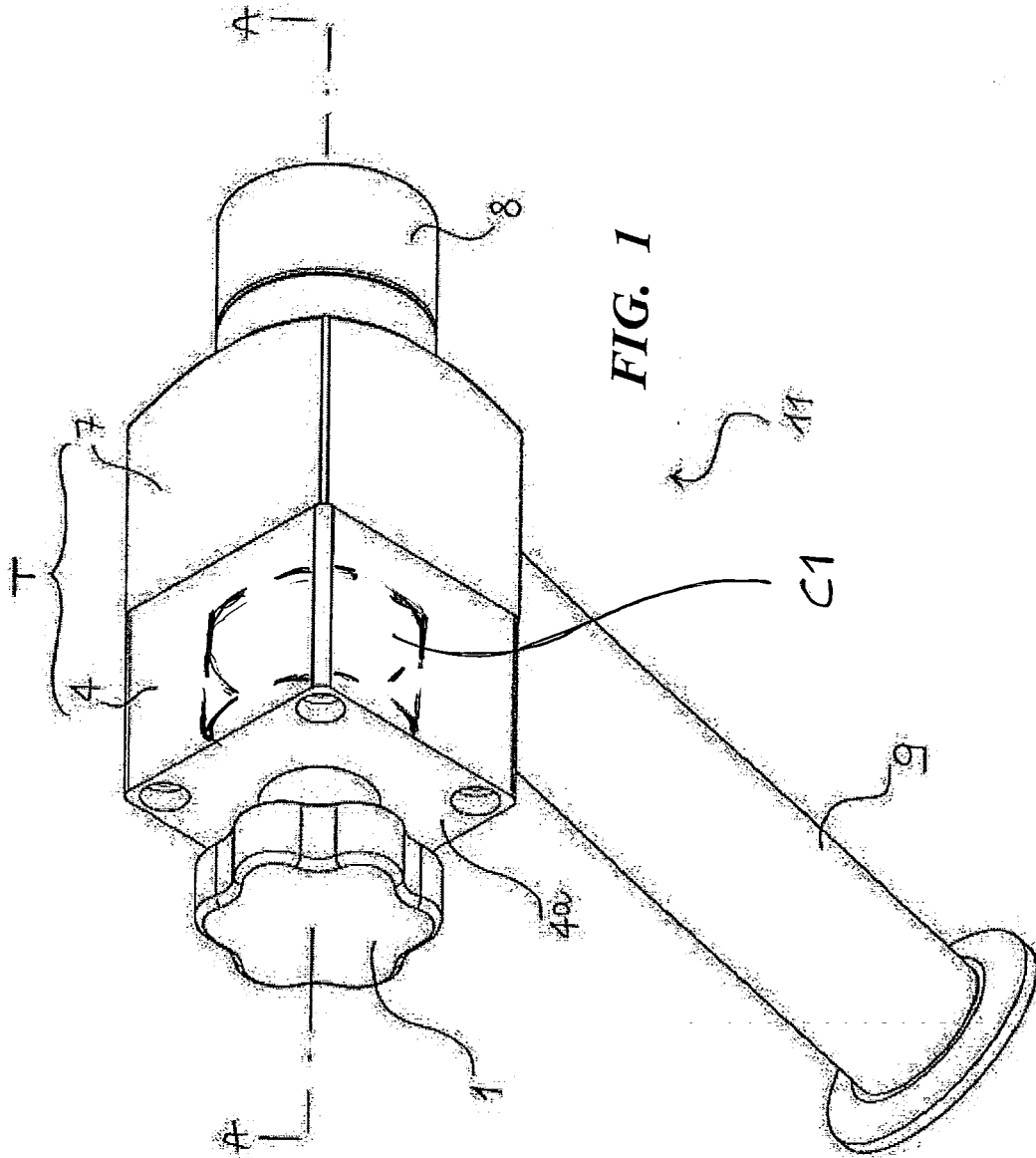

FIG. 2

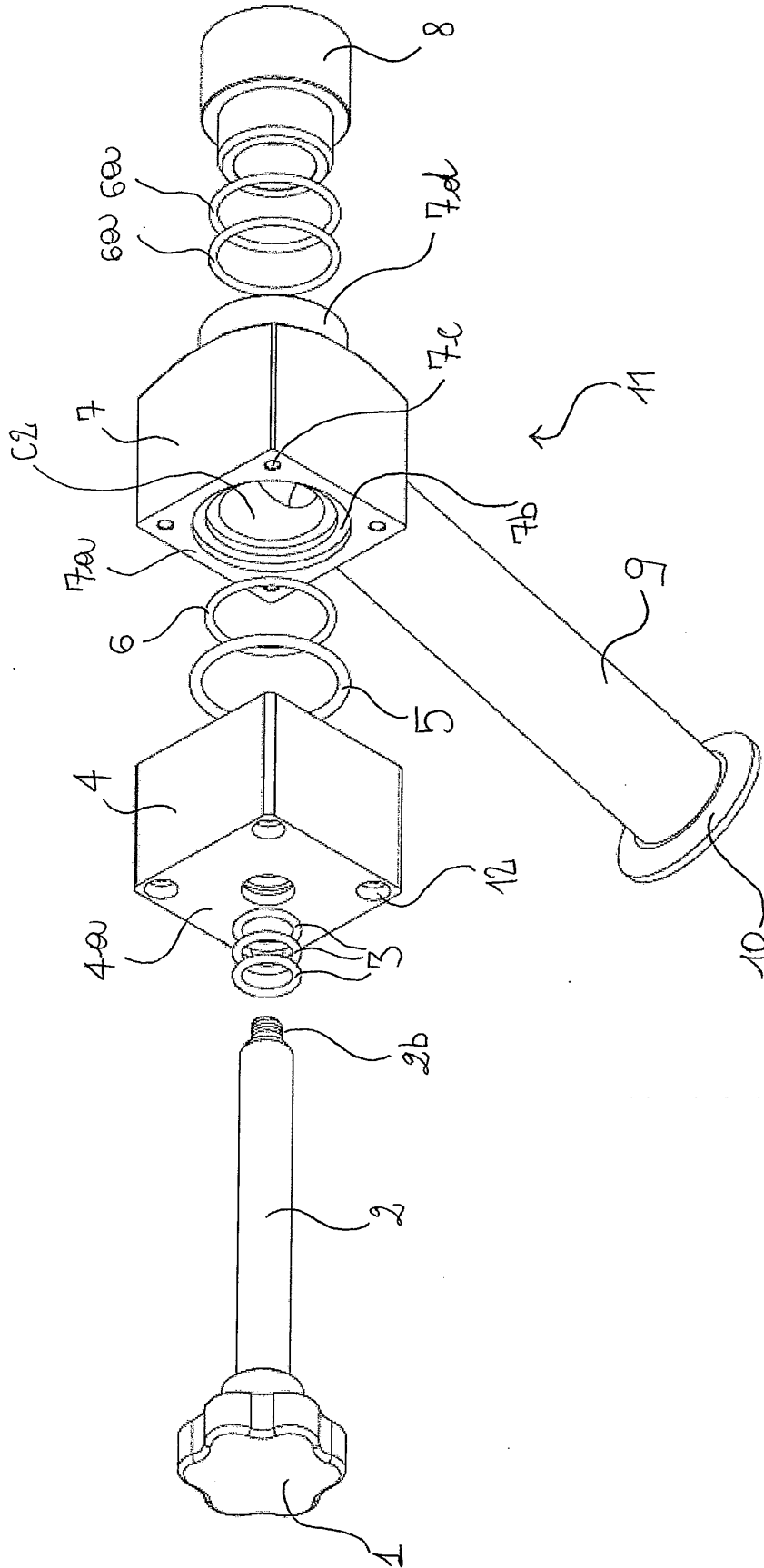
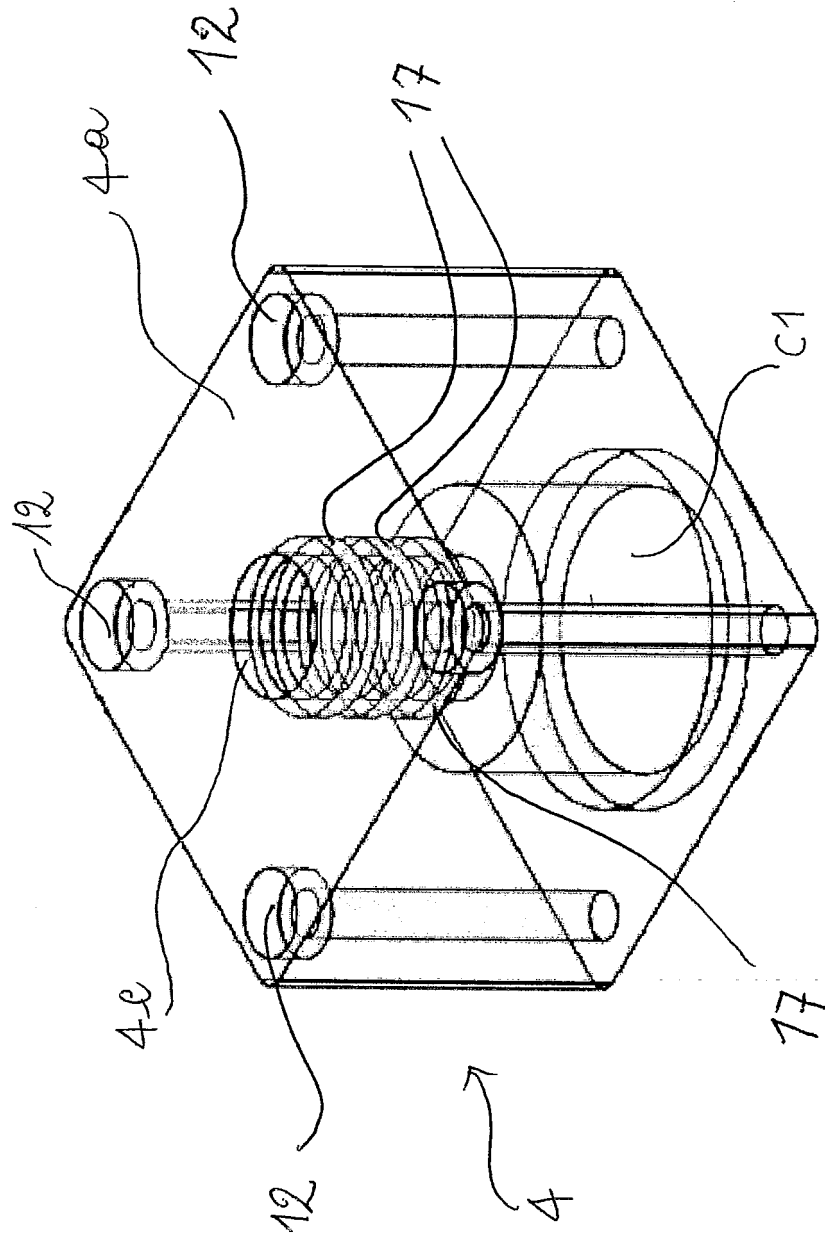
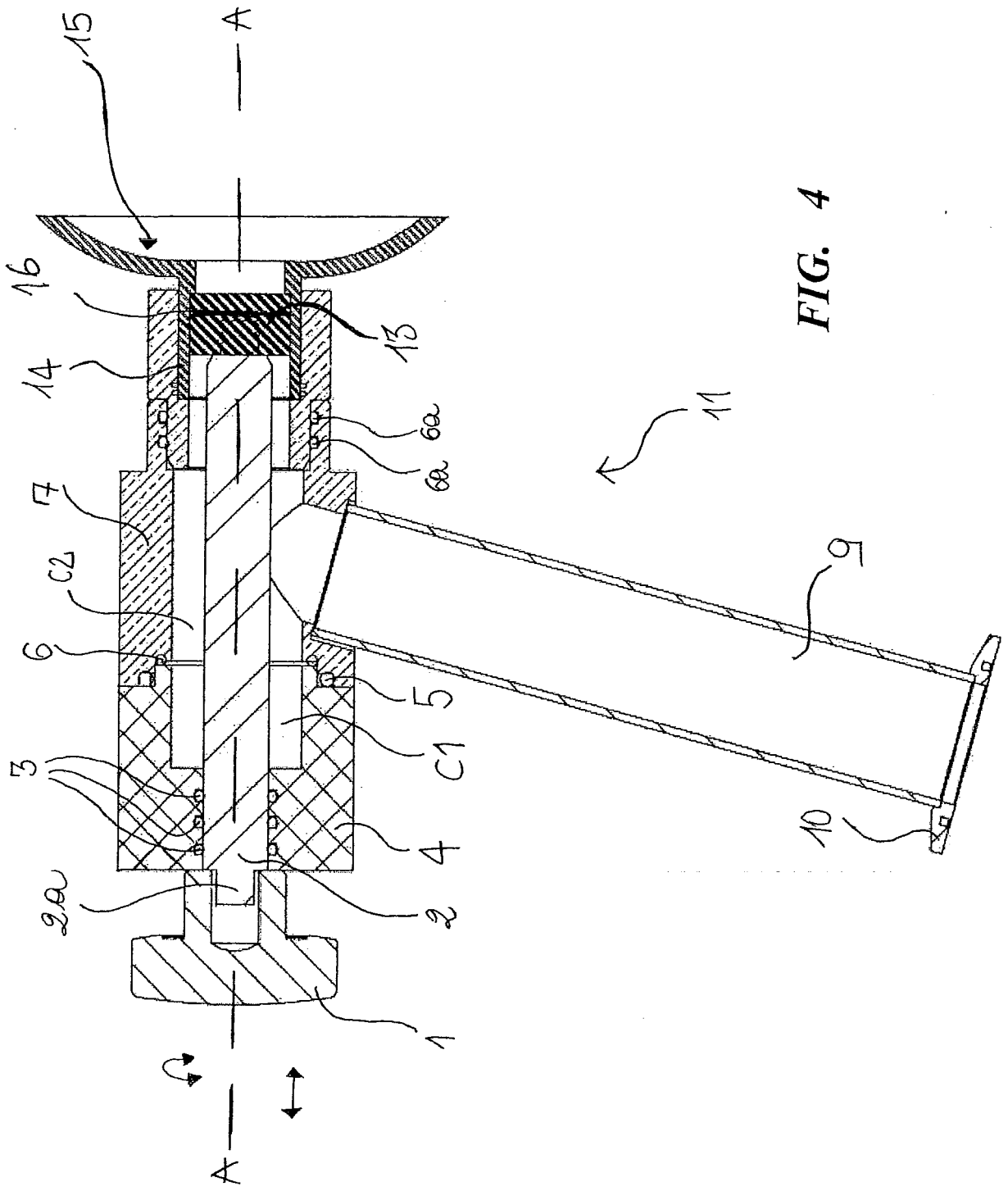

FIG. 3





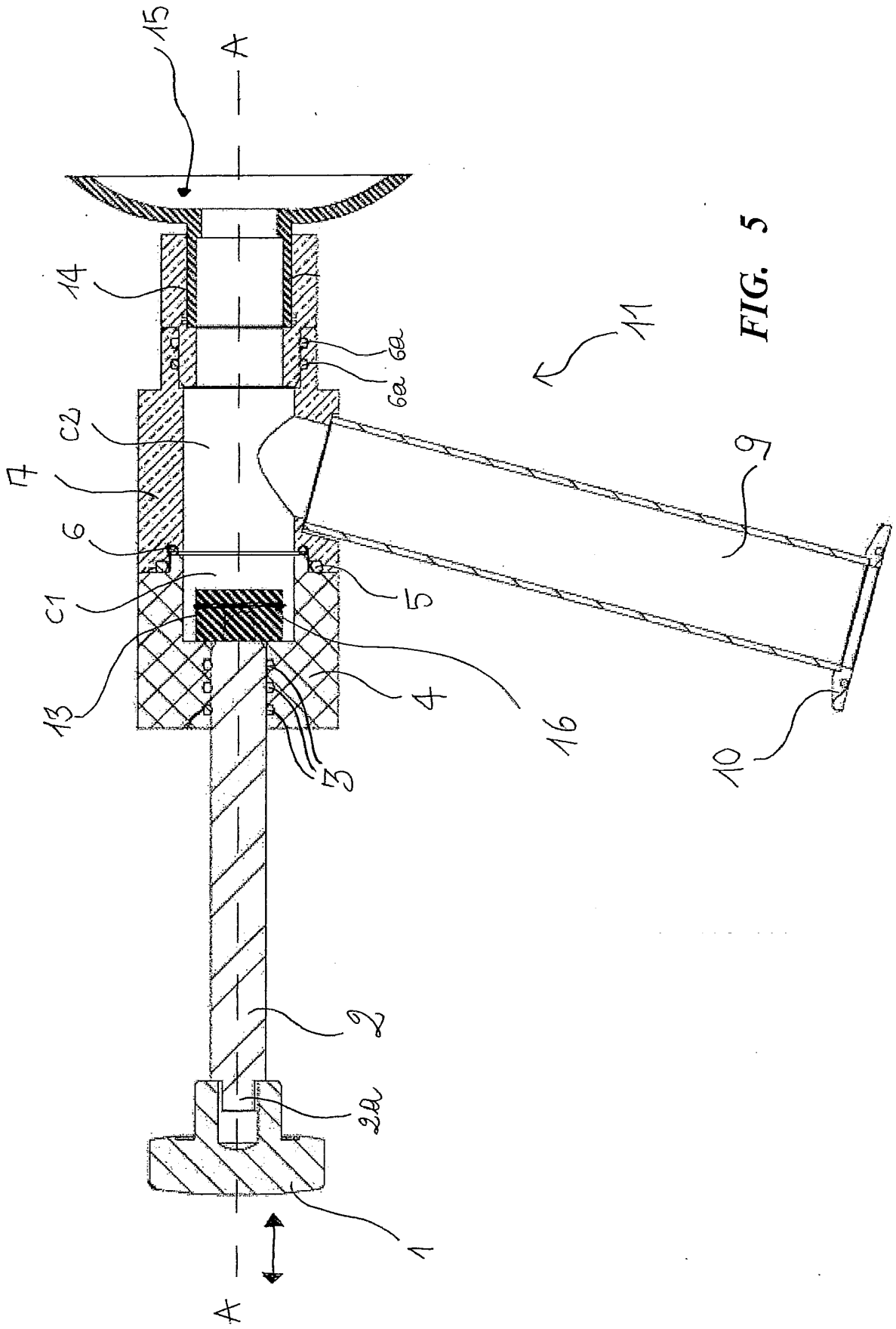
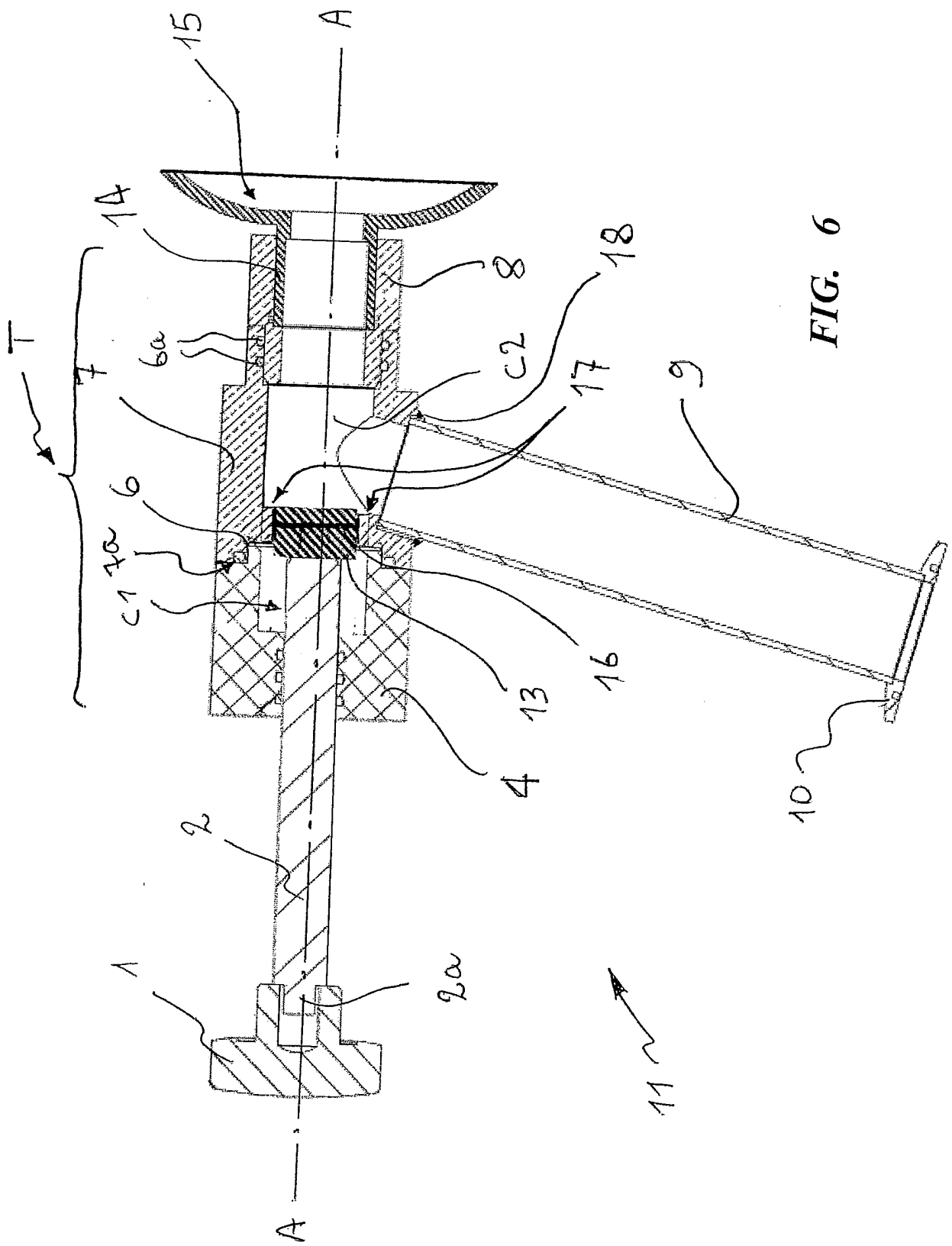

FIG. 5



REFERENCES CITED IN THE DESCRIPTION

This list of references cited by the applicant is for the reader's convenience only. It does not form part of the European patent document. Even though great care has been taken in compiling the references, errors or omissions cannot be excluded and the EPO disclaims all liability in this regard.

Patent documents cited in the description

- US 3364649 A [0008]