

(No Model.)

G. S. PRESTON.
THILL COUPLING.

No. 547,401.

Patented Oct. 1, 1895.

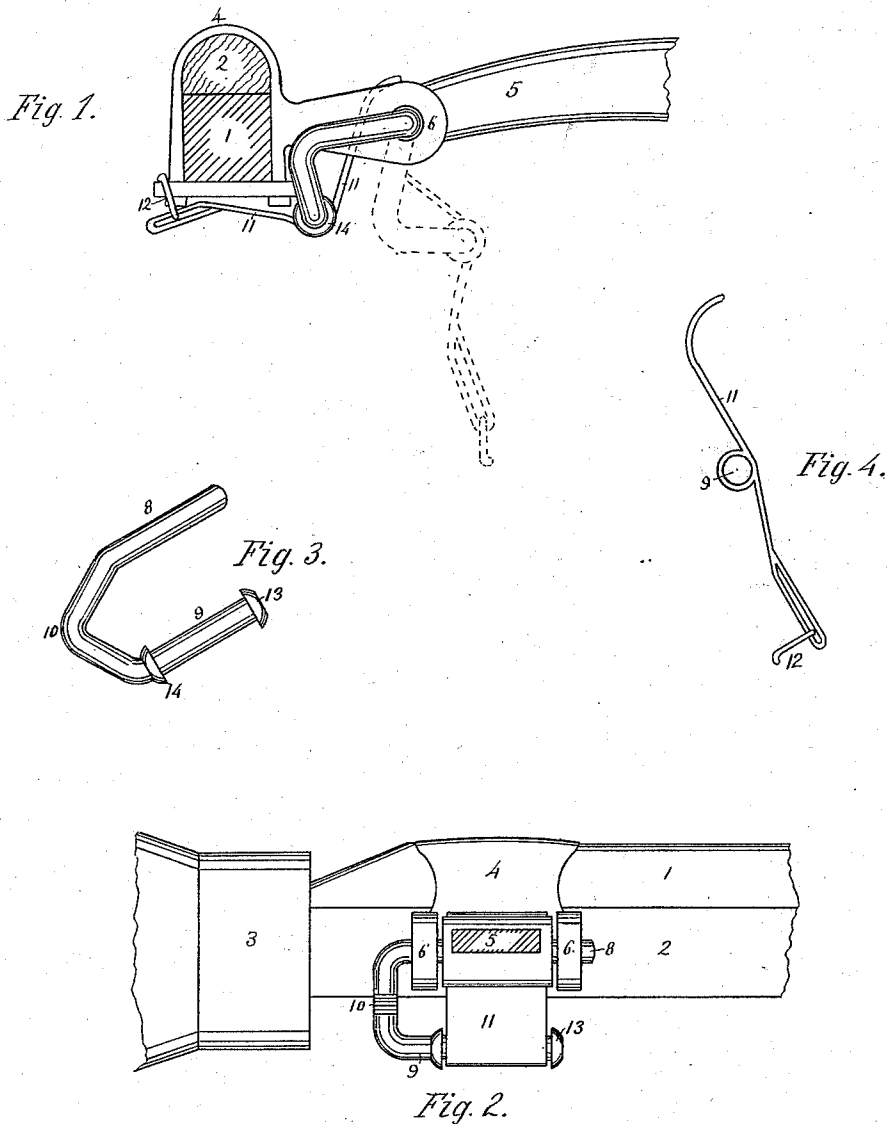

WITNESSES:
David Weed
Edward Smith

George S. Preston INVENTOR

BY *Joseph Smith*

ATTORNEY.

UNITED STATES PATENT OFFICE.

GEORGE S. PRESTON, OF TITUSVILLE, PENNSYLVANIA.

THILL-COUPLING.

SPECIFICATION forming part of Letters Patent No. 547,401, dated October 1, 1895.

Application filed April 30, 1895. Serial No. 547,699. (No model.)

To all whom it may concern:

Be it known that I, GEORGE S. PRESTON, a citizen of the United States, and a resident of Titusville, in the county of Crawford and State of Pennsylvania, have invented a new and useful Improvement in Thill-Couplings, of which the following is a specification.

My invention relates to the devices for coupling the thills or pole to the forward axle in carriages or wagons, principally to light pleasure-carriages, my object being to make one that, while safe and secure, can be easily and quickly removed and replaced, as when it is desired to change from thills to pole, or vice versa. I accomplish this in the device illustrated in the accompanying drawings, in which—

Figure 1 is a side view of my device, looking endwise of the axle, with the wheel removed and the axle shown in section; Fig. 2, a view from the front; Fig. 3, a view of the coupling-bolt, and Fig. 4 a side view of the spring.

In the several views the same numbers are used to indicate the same parts.

1 is the axle; 2, the stock; 3, the wheel band; 4, the ear-clip; 5, the end of the shaft or pole; 6, the clip-ears for receiving the shaft. So far the parts are the forms as commonly used.

My new coupler consists of a plain rod or large wire bent in the form shown in Fig. 3, a longer arm 8 taking the place of the ordinary bolt; but outside the ears of the clip it is bent at approximately right-angle bends into the form shown, so that the shorter arm 9 is in a line parallel to the arm 8 and a short distance outside the clip, while the short bend 10 between the two arms is so arranged that when the coupler is adjusted to place and secured it bears against the axle.

11 is a spring, preferably a band of spring-steel, of a width very slightly narrower than the distance between the ears of the clip. This spring is hinged on the arm 9, one end of the spring being adapted to pass in rear of and bear against the end of the shaft 5, the other arm being provided with a slot and in the slot the chain-link 12, adapted to be hooked over the rear end of the clip-tie of the clip 4. The spring is held on the arm 9 by a button 13, and preferably another shoulder 14 is placed on the bar inside of the spring, so as to

prevent the spring from slipping in either direction.

The application to the carriage is as follows: The hinge end of the shaft or pole being properly adjusted between the clip-ears the long arm 9 of the coupler is inserted in the place of the bolt, the end of the spring is brought to bear against the end of the shaft in the rear, the other end of the spring is brought up to the under side of the axle, the chain-link 12 is then hooked over the rear end of the clip-tie, and the coupling is complete. The spring 11, being between the collars 13 and 14 and also between the clip-ears 6, prevents the bolt from slipping out, and the pressure of the spring against the end of the shaft serves as an antirattler. The pressure of the spring holds the point of the elbow 10 against the axle, and if the pin is inserted from the wheel side of the clip the rim 3 of the wheel will also prevent the bolt from coming out. The coupling is preferably made right and left for that reason, so that the coupling on each side can be inserted from the wheel side.

The chief advantage to be derived from the use of this coupler is that it can be so easily applied and removed. When the spring is loosened, the bolt turns so that the elbow 10 of the bolt will pass outside of the rim 3 of the wheel, taking the position shown by dotted lines in Fig. 1. Therefore all that is needed to apply this coupler to any carriage is to remove the bolt, insert the arm 8 in its place, press down the spring, and hook the link 12 over the end of the clip-tie, and the coupling is complete.

I am aware that antirattlers have been made consisting of a spring made and applied in somewhat the same form as the spring herein described. Therefore I do not make any special claim on that alone.

What I do claim as my invention is—

1. An anti rattling thill coupler, consisting of the bent rod with the parallel arms 8, and 9, and the elbow 10, formed as shown; in combination with the spring 11, and chain link 12; constructed and applied substantially as shown and described.

2. A thill coupler, consisting of the bent rod with the parallel arms 8, and 9, and with

the elbow 10, formed as shown; the arm 8, for
insertion in place of the coupling bolt; the
arm 9, having hinged on it the spring 11, one
end of which is adapted to bear against the
5 rear end of the shaft or pole and the other
end to be brought under the axle and secured
to the clip by the chain link 12; all the parts

working in combination substantially as
shown and described.

GEORGE S. PRESTON.

Witnesses:

DAVID WEED,
J. J. HOLDEN.