



(51) International Patent Classification:

C07D 487/02 (2006.01) A01N 37/32 (2006.01)  
C07D 498/04 (2006.01) A01N 43/92 (2006.01)  
C07D 513/04 (2006.01) A01P 7/04 (2006.01)

(21) International Application Number:

PCT/EP2012/056253

(22) International Filing Date:

5 April 2012 (05.04.2012)

(25) Filing Language:

English

(26) Publication Language:

English

(30) Priority Data:

61/473,209 8 April 2011 (08.04.2011) US

(71) Applicant (for all designated States except US): **BASF SE** [DE/DE]; 67056 Ludwigshafen (DE).

(72) Inventors; and

(75) Inventors/Applicants (for US only): **PAULINI, Ralph** [DE/DE]; Im Nonnengarten 57, 67098 Bad Dürkheim (DE). **BEYER, Carsten** [DE/DE]; Leibnizstr. 40-42, 55118 Mainz (DE). **BASTIAANS, Henricus Maria Martinus** [NL/US]; 613 Aberdeen Drive, Chapel Hill, NC 27516 (US). **RANKL, Nancy, B.** [US/US]; 111 Bardsey Ct., Cary, NC 27513 (US).

(74) Common Representative: **BASF SE**; 67056 Ludwigshafen (DE).

(81) Designated States (unless otherwise indicated, for every kind of national protection available): AE, AG, AL, AM, AO, AT, AU, AZ, BA, BB, BG, BH, BR, BW, BY, BZ, CA, CH, CL, CN, CO, CR, CU, CZ, DE, DK, DM, DO, DZ, EC, EE, EG, ES, FI, GB, GD, GE, GH, GM, GT, HN, HR, HU, ID, IL, IN, IS, JP, KE, KG, KM, KN, KP, KR, KZ, LA, LC, LK, LR, LS, LT, LU, LY, MA, MD, ME, MG, MK, MN, MW, MX, MY, MZ, NA, NG, NI, NO, NZ, OM, PE, PG, PH, PL, PT, QA, RO, RS, RU, RW, SC, SD, SE, SG, SK, SL, SM, ST, SV, SY, TH, TJ, TM, TN, TR, TT, TZ, UA, UG, US, UZ, VC, VN, ZA, ZM, ZW.

(84) Designated States (unless otherwise indicated, for every kind of regional protection available): ARIPO (BW, GH, GM, KE, LR, LS, MW, MZ, NA, RW, SD, SL, SZ, TZ, UG, ZM, ZW), Eurasian (AM, AZ, BY, KG, KZ, MD, RU, TJ, TM), European (AL, AT, BE, BG, CH, CY, CZ, DE, DK, EE, ES, FI, FR, GB, GR, HR, HU, IE, IS, IT, LT, LU, LV, MC, MK, MT, NL, NO, PL, PT, RO, RS, SE, SI, SK, SM, TR), OAPI (BF, BJ, CF, CG, CI, CM, GA, GN, GQ, GW, ML, MR, NE, SN, TD, TG).

Published:

— with international search report (Art. 21(3))

(54) Title: N-SUBSTITUTED HETERO-BICYCLIC COMPOUNDS AND DERIVATIVES FOR COMBATING ANIMAL PESTS

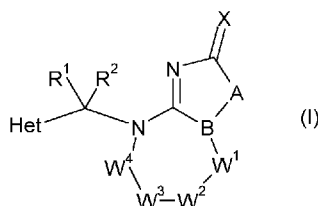

(57) Abstract: The invention relates to N-substituted hetero-bicyclic compounds of formula (I), to the enantiomers, diastereomers and salts thereof and to compositions comprising such compounds. The invention also relates to methods and uses of these N-substituted hetero-bicyclic compounds, and of compositions comprising thereof, for combating and controlling animal pests. Furthermore the invention relates also to pesticidal methods of applying such N-substituted hetero-bicyclic compounds. The N-substituted hetero-bicyclic compounds of the present invention are defined by the following formula (I): wherein A,B,X, Het, R<sup>1</sup>, R<sup>2</sup>, W<sup>1</sup>, W<sup>2</sup>, W<sup>3</sup> and W<sup>4</sup> are defined as in the description.



N-substituted hetero-bicyclic compounds and derivatives for combating animal pests

The present invention relates to N-substituted hetero-bicyclic compounds, to the enantiomers, diastereomers, derivatives and salts thereof and to compositions comprising such compounds. The invention also relates to the use of the N-substituted hetero-bicyclic compounds, of their salts or of compositions comprising them for combating animal pests. Furthermore the invention relates also to methods of applying such compounds.

Animal pests destroy growing and harvested crops and attack wooden dwelling and commercial structures, causing large economic loss to the food supply and to property. While a large number of pesticidal agents are known, due to the ability of target pests to develop resistance to said agents, there is an ongoing need for new agents for combating animal pests. In particular, animal pests such as insects and acaridae are difficult to be effectively controlled.

It is therefore an object of the present invention to provide compounds having a good pesticidal activity, especially against difficult to control insects and acaridae.

It has been found that these objects are solved by N-substituted hetero-bicyclic derivatives of the general formula I:

N-substituted hetero-bicyclic compounds of the general formula (I):

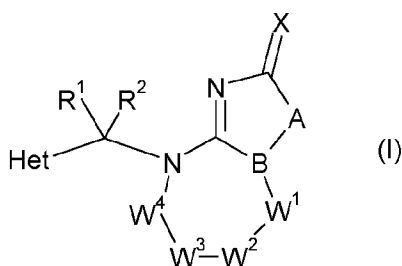

wherein

X is O or S;

A is selected from group consisting of O, S, NR<sup>3</sup>, CR<sup>4</sup>R<sup>5</sup>, A<sup>1a</sup>-A<sup>1b</sup> and A<sup>2a</sup>=A<sup>2b</sup>, wherein

A<sup>1a</sup>, A<sup>1b</sup> are each selected from O, S, NR<sup>3</sup> or CR<sup>4</sup>R<sup>5</sup>,

under the proviso that

A<sup>1a</sup> and A<sup>1b</sup> do not represent O and/or S at the same time,

and

A<sup>2a</sup>, A<sup>2b</sup> are independently from one another N or CR<sup>6</sup>;

B is N or CR<sup>7</sup>;

5

W<sup>1</sup>, W<sup>2</sup>, W<sup>3</sup>

and W<sup>4</sup> represent a chain group connected to N and B, and thus forming a saturated or unsaturated 5-, 6- or 7-membered heterocycle, wherein W<sup>1</sup>, W<sup>2</sup>, W<sup>3</sup> and W<sup>4</sup> each individually represent CR<sup>6</sup>, CR<sup>4</sup>R<sup>5</sup>, N, NR<sup>3</sup>, O, S(O)<sub>n</sub> or C=Y, wherein Y is selected from C(R<sup>6</sup>)<sub>2</sub>, O, S or NR<sup>3</sup>, and wherein

10

W<sup>2</sup> and W<sup>3</sup> may further represent each individually, or both together, a single or double bond;

15

and under the proviso that

(i) not more than two of W<sup>1</sup>, W<sup>2</sup>, W<sup>3</sup> and W<sup>4</sup> represent O, NR<sup>3</sup>, S(O)<sub>n</sub> or C=Y at the same time, and/or

(ii) if two of W<sup>1</sup>, W<sup>2</sup>, W<sup>3</sup> and W<sup>4</sup> represent

20

O or S(O)<sub>n</sub>, then at least one carbon atom is present between them;

Het is a 5 or 6 membered C-bound saturated, unsaturated or aromatic heterocycle, having at least one heteroatom group, selected from O, S and N-R<sup>3</sup>, as ring member and optionally 1 or 2 further N atoms as ring member, wherein

25

the heterocycle is unsubstituted or carries at its carbon atoms 1 or 2 radicals R<sup>8</sup>, wherein

R<sup>8</sup> is selected from the group consisting of hydrogen, halogen, C<sub>1</sub>-C<sub>6</sub>-alkyl, C<sub>3</sub>-C<sub>6</sub>-cycloalkyl, C<sub>2</sub>-C<sub>6</sub>-alkenyl, C<sub>2</sub>-C<sub>6</sub>-alkynyl, C<sub>1</sub>-C<sub>6</sub>-alkoxy, C<sub>2</sub>-C<sub>6</sub>-alkenyloxy, C<sub>2</sub>-C<sub>6</sub>-alkynyloxy, C<sub>1</sub>-C<sub>4</sub>-alkylthio, CN, NO<sub>2</sub>, S(O)<sub>m</sub>R<sup>c</sup>, C(O)R<sup>c</sup>, C(O)OR<sup>a</sup>, C(O)NR<sup>a</sup>R<sup>b</sup> and C(S)NR<sup>a</sup>R<sup>b</sup>, wherein the aforementioned alkyl, cycloalkyl, alkenyl, alkynyl, alkoxy, alkylthio, alkenyloxy and alkynyloxy radicals are unsubstituted, partly or completely halogenated or may carry any combination of 1, 2 or 3 radicals R<sup>d</sup>;

35

- R<sup>1</sup>, R<sup>2</sup> are selected independently from one another from the group consisting of hydrogen, halogen, C<sub>1</sub>-C<sub>6</sub>-alkyl, C<sub>3</sub>-C<sub>6</sub>-cycloalkyl, C<sub>2</sub>-C<sub>6</sub>-alkenyl, C<sub>2</sub>-C<sub>6</sub>-alkynyl, C<sub>1</sub>-C<sub>6</sub>-alkoxy, C<sub>1</sub>-C<sub>6</sub>-alkylthio, CN, NO<sub>2</sub>, C(O)R<sup>c</sup>, C(O)OR<sup>a</sup>, C(O)NR<sup>a</sup>R<sup>b</sup>, C(S)NR<sup>a</sup>R<sup>b</sup> and S(O)<sub>m</sub>R<sup>c</sup>, wherein
- 5 the aforementioned alkyl, cycloalkyl, alkenyl, alkynyl, alkoxy and alkylthio radicals are unsubstituted, partly or completely halogenated or may carry any combination of 1, 2 or 3 radicals R<sup>d</sup>; or
- R<sup>1</sup> and R<sup>2</sup> from, together with the carbon atom, which they attached to, a 3- to 6-membered saturated carbocycle, wherein
- 10 each of the carbon atoms of said carbocycle are unsubstituted or may carry any combination of 1 or 2 radicals R<sup>d</sup>.
- R<sup>3</sup> is selected, and if more than one R<sup>3</sup> is present, independently from one another, from the group consisting of hydrogen, C<sub>1</sub>-C<sub>6</sub>-alkyl, C<sub>1</sub>-C<sub>6</sub>-haloalkyl,
- 15 C<sub>3</sub>-C<sub>6</sub>-cycloalkyl, C<sub>2</sub>-C<sub>6</sub>-alkenyl, C<sub>2</sub>-C<sub>6</sub>-haloalkenyl, C<sub>2</sub>-C<sub>6</sub>-alkynyl, C<sub>2</sub>-C<sub>6</sub>-haloalkynyl, C(O)R<sup>c</sup>, C(S)R<sup>c</sup>, C(O)OR<sup>a</sup>, C(O)NR<sup>a</sup>R<sup>b</sup>, C(S)NR<sup>a</sup>R<sup>b</sup> and S(O)<sub>m</sub>R<sup>c</sup> and S(O)<sub>m</sub>NR<sup>a</sup>R<sup>b</sup>, and wherein
- the aforementioned alkyl, cycloalkyl, alkenyl and alkynyl radicals are unsubstituted or may carry any combination of 1, 2 or 3 radicals R<sup>d</sup>,
- 20
- R<sup>4</sup>, R<sup>5</sup> are independently from one another selected from the group consisting of hydrogen, halogen, C<sub>1</sub>-C<sub>6</sub>-alkyl, C<sub>3</sub>-C<sub>6</sub>-cycloalkyl, C<sub>2</sub>-C<sub>6</sub>-alkenyl and C<sub>2</sub>-C<sub>6</sub>-alkynyl, wherein
- the aforementioned alkyl, cycloalkyl, alkenyl and alkynyl radicals are
- 25 unsubstituted, partly or completely halogenated or may carry any combination of 1, 2 or 3 radicals R<sup>d</sup>;
- R<sup>6</sup> is selected, and if more than one R<sup>6</sup> is present, independently from one another, from the group consisting of hydrogen, halogen, C<sub>1</sub>-C<sub>6</sub>-alkyl, C<sub>1</sub>-C<sub>6</sub>-alkoxy and C<sub>1</sub>-C<sub>6</sub>-alkylthio, wherein carbon atoms of the
- 30 aforementioned radicals are unsubstituted, partly or completely halogenated or may carry any combination of 1, 2 or 3 radicals R<sup>d</sup>;
- R<sup>7</sup> has one of the meanings given for R<sup>6</sup>,
- 35 or
- R<sup>7</sup> represents a bond to the neighboring atom W<sup>1</sup> such that B and W<sup>1</sup> are connected by a double bond, under the proviso,

that in this case  $W^1$  does not represent  $CR^4R^5$ ,  $NR^3$ ,  $O$ ,  $S(O)_n$  or  $C=Y$ ;

- 5  $R^a$ ,  $R^b$  are selected independently from one another from the group consisting of hydrogen,  $C_1$ - $C_4$ -alkyl,  $C_1$ - $C_4$ -haloalkyl,  $C_3$ - $C_6$ -cycloalkyl,  $C_3$ - $C_6$ -alkenyl,  $C_3$ - $C_6$ -haloalkenyl and  $C_3$ - $C_6$ -alkynyl;
- $R^c$  is selected from the group consisting of  $C_1$ - $C_4$ -alkyl,  $C_1$ - $C_4$ -haloalkyl,  $C_3$ - $C_6$ -cycloalkyl,  $C_2$ - $C_6$ -alkenyl,  $C_2$ - $C_6$ -haloalkenyl and  $C_2$ - $C_6$ -alkynyl;
- 10  $R^d$  is selected from the group consisting of halogen,  $C_1$ - $C_4$ -alkyl,  $C_3$ - $C_6$ -cycloalkyl,  $C_2$ - $C_6$ -alkenyl,  $C_2$ - $C_6$ -alkynyl,  $C_1$ - $C_4$ -alkoxy,  $C_2$ - $C_6$ -alkenyloxy,  $C_2$ - $C_6$ -alkynyloxy,  $C_1$ - $C_4$ -alkylthio,  $C_1$ - $C_4$ -alkoxy- $C_1$ - $C_4$ -alkyl,  $C_1$ - $C_4$ -alkylthio- $C_1$ - $C_4$ -alkyl, wherein all carbon atoms of the
- 15 fully halogenated,  $NO_2$ ,  $CN$ ,  $NR^eR^f$ ,  $C(O)R^c$ ,  $C(S)R^c$ ,  $C(O)OR^a$ ,  $C(O)NR^aR^b$ ,  $C(S)NR^aR^b$  or  $S(O)_mR^c$ ,  $S(O)_mNR^aR^b$ , phenyl, heteroaryl, phenyl- $C_1$ - $C_4$ -alkyl and heteroaryl- $C_1$ - $C_4$ -alkyl,
- 20 wherein the rings of the four last mentioned radicals may carry 1, 2, 3, 4 or 5 substituents, which, independently from each other are selected from halogen,  $NO_2$ ,  $CN$ ,  $C_1$ - $C_4$ -alkyl,  $C_1$ - $C_4$ -haloalkyl,  $C_1$ - $C_4$ -alkoxy and  $C_1$ - $C_4$ -haloalkoxy;
- $R^e$ ,  $R^f$  are selected independently from one another from the group consisting of hydrogen,  $C_1$ - $C_4$ -alkyl,  $C_1$ - $C_4$ -haloalkyl,  $C_3$ - $C_6$ -cycloalkyl,  $C_3$ - $C_6$ -alkenyl,  $C_3$ - $C_6$ -haloalkenyl,  $C_3$ - $C_6$ -alkynyl,  $C(O)R^c$ ,  $C(O)OR^a$ ,
- 25  $C(O)NR^aR^b$  and  $C(S)NR^aR^b$ ;
- $n$ ,  $m$  are integers selected from 0, 1 or 2;
- 30 and/or their enantiomers or diastereomers or agriculturally or veterinary acceptable salts, and

with the proviso, that the compound of formula (I) is not representing 4-pyridin-2-ylmethyl-4H-oxazolo[4,5-b]pyridin-2-one or 4-thiophen-2-ylmethyl-4H-oxazolo[4,5-b]pyridin-2-one.

35

Such insecticidal active N-substituted hetero-bicyclic compounds according to the present invention have not been described in the art before.

CH 461489 shows two examples of oxazole derivatives, namely 4-pyridin-2-ylmethyl-4H-oxazolo[4,5-b]pyridin-2-one and 4-thiophen-2-ylmethyl-4H-oxazolo[4,5-b]pyridin-2-one

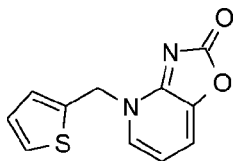
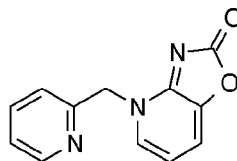
example 9b<sup>3</sup>)example 11b<sup>3</sup>)

5

for pharmaceutical purposes such as having analgetic and antiphlogistic properties. No further N-substituted hetero-bicyclic derivatives are disclosed in CH 461 489 and no pesticidal activity of any of the compounds therein is described

10

Substituted enamino(thio)carbonyl compounds having pesticidal activity are described in DE 10 2006 015 467, DE 10 2006 015 470, WO2007/115647 and WO2009/121507. Pesticidal active isoxazole derivatives are described in DE 198 38 138. Insecticidal cyclic carbonyl amidines are disclosed in WO 2010/005692 and EP 0 259 738 describes heterocyclic substituted compounds with insecticidal activity.

15

The N- substituted hetero-bicyclic compounds of the formula I, and their agriculturally acceptable salts are highly active against animal pest, i.e. harmful arthropodes and nematodes, especially against difficult to control insects and acaridae.

20

Accordingly, the present invention relates to N-substituted hetero-bicyclic compounds of the general formula I, to their agriculturally or veterinarily useful salts, their enantiomers or diastereomers.

25

Moreover, the present invention relates to and includes the following embodiments:

- agricultural and veterinary compositions comprising an amount of at least one compound of the formula I or an enantiomer, diastereomer or salt thereof;
- the use of a compound of formula I or an enantiomer, diastereomer or salt thereof for combating animal pests;
- a method of combating animal pests which comprises contacting the animal pests, their habit, breeding ground, food supply, plant, seed, soil, area, material or environment in which the animal pests are growing or may grow, or the materials, plants, seeds, soils, surfaces or spaces to be protected from animal attack or infestation with a pesticidally effective amount of at least one compound of the formula I or an enantiomer, diastereomer or salt thereof;
- a method for protecting crops from attack or infestation by animal pests, which comprises contacting a crop with a pesticidally effective amount of at least one compound of the formula I or an enantiomer, diastereomer or salt thereof;

30

35

- 5 - a method for the protection of plant propagation, especially seeds, from soil insects and of the seedlings' roots and shoots from soil and foliar insects comprising contacting the seeds before sowing and/or after pregermination with at least one compound of the formula I, or the enantiomers, diastereomers or salts thereof;
- seeds comprising a compound of the formula I or an enantiomer, diastereomer or salt thereof;
- the use of compounds of formula I or the enantiomers, diastereomers or veterinary acceptable salts thereof for combating parasites in and on animals.
- 10 - a method for treating, controlling, preventing or protecting animals against infestation or infection by parasites which comprises orally, topically or parenterally administering or applying to the animals a parasitically effective amount of an compound of formula I or the enantiomers, diastereomers and/or veterinary acceptable salt thereof;
- 15 - a process for the preparation of a veterinary composition for treating, controlling, preventing or protecting animals against infestation or infection by parasites which comprises adding a parasitically effective amount of an compound of formula I or the enantiomers, diastereomers and/or veterinary acceptable salt thereof to a carrier composition suitable for veterinary use;
- 20 - the use of a compound of formula I or the enantiomers, diastereomers and/or veterinary acceptable salt thereof for the preparation of a medicament for treating, controlling, preventing or protecting animals against infestation or infection by parasites;

25 The present invention especially relates to plant propagation materials, in particular as mentioned above to seeds, comprising at least one compound of formula I and/or an agriculturally acceptable salt thereof.

30 The present invention relates to every possible stereoisomer of the compounds of formula I, i.e. to single enantiomers or diastereomers, as well as to mixtures thereof.

35 The compounds of the present invention may be amorphous or may exist in one or more different crystalline states (polymorphs) or modifications which may have a different macroscopic properties such as stability or show different biological properties such as activities. The present invention includes both amorphous and crystalline compounds of the formula I, mixtures of different crystalline states or modifications of the respective compound I, as well as amorphous or crystalline salts thereof.

40 Salts of the compounds of the formula I are preferably agriculturally and/or veterinary acceptable salts. They can be formed in a customary method, e.g. by reacting the compound with an acid of the anion in question if the compound of formula I has a basic functionality or by reacting an acidic compound of formula I with a suitable base.

Suitable agriculturally or veterinary useful salts are especially the salts of those cations or the acid addition salts of those acids whose cations and anions, respectively, do not have any adverse effect on the action of the compounds according to the present invention. Suitable cations are in particular the ions of the alkali metals, preferably lithium, sodium and potassium, of the alkaline earth metals, preferably calcium, magnesium and barium, and of the transition metals, preferably manganese, copper, zinc and iron, and also ammonium (NH<sub>4</sub><sup>+</sup>) and substituted ammonium in which one to four of the hydrogen atoms are replaced by C<sub>1</sub>-C<sub>4</sub>-alkyl, C<sub>1</sub>-C<sub>4</sub>-hydroxyalkyl, C<sub>1</sub>-C<sub>4</sub>-alkoxy, C<sub>1</sub>-C<sub>4</sub>-alkoxy-C<sub>1</sub>-C<sub>4</sub>-alkyl, hydroxy-C<sub>1</sub>-C<sub>4</sub>-alkoxy-C<sub>1</sub>-C<sub>4</sub>-alkyl, phenyl or benzyl. Examples of substituted ammonium ions comprise methylammonium, isopropylammonium, dimethylammonium, diisopropylammonium, trimethylammonium, tetramethylammonium, tetraethylammonium, tetrabutylammonium, 2-hydroxyethylammonium, 2-(2-hydroxyethoxy)ethyl-ammonium, bis(2-hydroxyethyl)ammonium, benzyltrimethylammonium and benzyltriethylammonium, furthermore phosphonium ions, sulfonium ions, preferably tri(C<sub>1</sub>-C<sub>4</sub>-alkyl)sulfonium, and sulfoxonium ions, preferably tri(C<sub>1</sub>-C<sub>4</sub>-alkyl)sulfoxonium.

Anions of useful acid addition salts are primarily chloride, bromide, fluoride, hydrogen sulfate, sulfate, dihydrogen phosphate, hydrogen phosphate, phosphate, nitrate, hydrogen carbonate, carbonate, hexafluorosilicate, hexafluorophosphate, benzoate, and the anions of C<sub>1</sub>-C<sub>4</sub>-alkanoic acids, preferably formate, acetate, propionate and butyrate. They can be formed by reacting the compounds of the formulae I with an acid of the corresponding anion, preferably of hydrochloric acid, hydrobromic acid, sulfuric acid, phosphoric acid or nitric acid.

The organic moieties mentioned in the above definitions of the variables are - like the term halogen - collective terms for individual listings of the individual group members. The prefix C<sub>n</sub>-C<sub>m</sub> indicates in each case the possible number of carbon atoms in the group.

"Halogen" will be taken to mean fluoro, chloro, bromo and iodo.

The term "partially or fully halogenated" will be taken to mean that 1 or more, e.g. 1, 2, 3, 4 or 5 or all of the hydrogen atoms of a given radical have been replaced by a halogen atom, in particular by fluorine or chlorine.

The term "C<sub>n</sub>-C<sub>m</sub>-alkyl" as used herein (and also in C<sub>n</sub>-C<sub>m</sub>-alkylamino, di-C<sub>n</sub>-C<sub>m</sub>-alkylamino, C<sub>n</sub>-C<sub>m</sub>-alkylaminocarbonyl, di-(C<sub>n</sub>-C<sub>m</sub>-alkylamino)carbonyl, C<sub>n</sub>-C<sub>m</sub>-alkylthio, C<sub>n</sub>-C<sub>m</sub>-alkylsulfinyl and C<sub>n</sub>-C<sub>m</sub>-alkylsulfonyl) refers to a branched or unbranched saturated hydrocarbon group having n to m, e.g. 1 to 10 carbon atoms, preferably 1 to 6 carbon atoms, for example methyl, ethyl, propyl, 1-methylethyl, butyl, 1-methylpropyl, 2-methylpropyl, 1,1-dimethylethyl, pentyl, 1-methylbutyl, 2-methylbutyl, 3-methylbutyl, 2,2-dimethylpropyl, 1-ethylpropyl, hexyl, 1,1-dimethylpropyl, 1,2-dimethylpropyl, 1-

methylpentyl, 2-methylpentyl, 3-methylpentyl, 4-methylpentyl, 1,1-dimethylbutyl, 1,2-dimethylbutyl, 1,3-dimethylbutyl, 2,2-dimethylbutyl, 2,3-dimethylbutyl, 3,3-dimethylbutyl, 1-ethylbutyl, 2-ethylbutyl, 1,1,2-trimethylpropyl, 1,2,2-trimethylpropyl, 1-ethyl-1-methylpropyl, 1-ethyl-2-methylpropyl, heptyl, octyl, 2-ethylhexyl, nonyl and decyl and  
5 their isomers. C<sub>1</sub>-C<sub>4</sub>-alkyl means for example methyl, ethyl, propyl, 1-methylethyl, butyl, 1-methylpropyl, 2-methylpropyl or 1,1-dimethylethyl.

The term "C<sub>n</sub>-C<sub>m</sub>-haloalkyl" as used herein (and also in C<sub>n</sub>-C<sub>m</sub>-haloalkylsulfinyl and C<sub>n</sub>-C<sub>m</sub>-haloalkylsulfonyl) refers to a straight-chain or branched alkyl group having n to m  
10 carbon atoms, e.g. 1 to 10 in particular 1 to 6 carbon atoms (as mentioned above), where some or all of the hydrogen atoms in these groups may be replaced by halogen atoms as mentioned above, for example C<sub>1</sub>-C<sub>4</sub>-haloalkyl, such as chloromethyl, bromomethyl, dichloromethyl, trichloromethyl, fluoromethyl, difluoromethyl, trifluoromethyl, chlorofluoromethyl, dichlorofluoromethyl, chlorodifluoromethyl, 1-chloroethyl, 1-  
15 bromoethyl, 1-fluoroethyl, 2-fluoroethyl, 2,2-difluoroethyl, 2,2,2-trifluoroethyl, 2-chloro-2-fluoroethyl, 2-chloro-2,2-difluoroethyl, 2,2-dichloro-2-fluoroethyl, 2,2,2-trichloroethyl, pentafluoroethyl and the like. The term C<sub>1</sub>-C<sub>10</sub>-haloalkyl in particular comprises C<sub>1</sub>-C<sub>2</sub>-fluoroalkyl, which is synonym with methyl or ethyl, wherein 1, 2, 3, 4 or 5 hydrogen atoms are substituted by fluorine atoms, such as fluoromethyl, difluoromethyl, trifluoro-  
20 methyl, 1-fluoroethyl, 2-fluoroethyl, 2,2-difluoroethyl, 2,2,2-trifluoroethyl and pentafluoromethyl.

Similarly, "C<sub>n</sub>-C<sub>m</sub>-alkoxy" and "C<sub>n</sub>-C<sub>m</sub>-alkylthio" (or C<sub>n</sub>-C<sub>m</sub>-alkylsulphenyl, respectively) refer to straight-chain or branched alkyl groups having n to m carbon atoms, e.g. 1 to  
25 10, in particular 1 to 6 or 1 to 4 carbon atoms (as mentioned above) bonded through oxygen or sulfur linkages, respectively, at any bond in the alkyl group. Examples include C<sub>1</sub>-C<sub>4</sub>-alkoxy such as methoxy, ethoxy, propoxy, isopropoxy, butoxy, sec-butoxy, isobutoxy and tert-butoxy, further C<sub>1</sub>-C<sub>4</sub>-alkylthio such as methylthio, ethylthio, propylthio, isopropylthio, and n-butylthio.

30 Accordingly, the terms "C<sub>n</sub>-C<sub>m</sub>-haloalkoxy" and "C<sub>n</sub>-C<sub>m</sub>-haloalkylthio" (or C<sub>n</sub>-C<sub>m</sub>-haloalkylsulphenyl, respectively) refer to straight-chain or branched alkyl groups having n to m carbon atoms, e.g. 1 to 10, in particular 1 to 6 or 1 to 4 carbon atoms (as mentioned above) bonded through oxygen or sulfur linkages, respectively, at any bond in  
35 the alkyl group, where some or all of the hydrogen atoms in these groups may be replaced by halogen atoms as mentioned above, for example C<sub>1</sub>-C<sub>2</sub>-haloalkoxy, such as chloromethoxy, bromomethoxy, dichloromethoxy, trichloromethoxy, fluoromethoxy, difluoromethoxy, trifluoromethoxy, chlorofluoromethoxy, dichlorofluoromethoxy, chlorodifluoromethoxy, 1-chloroethoxy, 1-bromoethoxy, 1-fluoroethoxy, 2-fluoroethoxy, 2,2-  
40 difluoroethoxy, 2,2,2-trifluoroethoxy, 2-chloro-2-fluoroethoxy, 2-chloro-2,2-difluoroethoxy, 2,2-dichloro-2-fluoroethoxy, 2,2,2-trichloroethoxy and pentafluoroethoxy, further C<sub>1</sub>-C<sub>2</sub>-haloalkylthio, such as chloromethylthio, bromomethylthio, dichloromethylthio, trichloromethylthio, fluoromethylthio, difluoromethylthio, trifluoromethylthio,

chlorofluoromethylthio, dichlorofluoromethylthio, chlorodifluoromethylthio, 1-chloroethylthio, 1-bromoethylthio, 1-fluoroethylthio, 2-fluoroethylthio, 2,2-difluoroethylthio, 2,2,2-trifluoroethylthio, 2-chloro-2-fluoroethylthio, 2-chloro-2,2-difluoroethylthio, 2,2-dichloro-2-fluoroethylthio, 2,2,2-trichloroethylthio and pentafluoroethylthio and the like. Similarly the terms C<sub>1</sub>-C<sub>2</sub>-fluoroalkoxy and C<sub>1</sub>-C<sub>2</sub>-fluoroalkylthio refer to C<sub>1</sub>-C<sub>2</sub>-fluoroalkyl which is bound to the remainder of the molecule via an oxygen atom or a sulfur atom, respectively.

The term "C<sub>2</sub>-C<sub>m</sub>-alkenyl" as used herein intends a branched or unbranched unsaturated hydrocarbon group having 2 to m, e.g. 2 to 10 or 2 to 6 carbon atoms and a double bond in any position, such as ethenyl, 1-propenyl, 2-propenyl, 1-methyl-ethenyl, 1-butenyl, 2-butenyl, 3-butenyl, 1-methyl-1-propenyl, 2-methyl-1-propenyl, 1-methyl-2-propenyl, 2-methyl-2-propenyl, 1-pentenyl, 2-pentenyl, 3-pentenyl, 4-pentenyl, 1-methyl-1-butenyl, 2-methyl-1-butenyl, 3-methyl-1-butenyl, 1-methyl-2-butenyl, 2-methyl-2-butenyl, 3-methyl-2-butenyl, 1-methyl-3-butenyl, 2-methyl-3-butenyl, 3-methyl-3-butenyl, 1,1-dimethyl-2-propenyl, 1,2-dimethyl-1-propenyl, 1,2-dimethyl-2-propenyl, 1-ethyl-1-propenyl, 1-ethyl-2-propenyl, 1-hexenyl, 2-hexenyl, 3-hexenyl, 4-hexenyl, 5-hexenyl, 1-methyl-1-pentenyl, 2-methyl-1-pentenyl, 3-methyl-1-pentenyl, 4-methyl-1-pentenyl, 1-methyl-2-pentenyl, 2-methyl-2-pentenyl, 3-methyl-2-pentenyl, 4-methyl-2-pentenyl, 1-methyl-3-pentenyl, 2-methyl-3-pentenyl, 3-methyl-3-pentenyl, 4-methyl-3-pentenyl, 1-methyl-4-pentenyl, 2-methyl-4-pentenyl, 3-methyl-4-pentenyl, 4-methyl-4-pentenyl, 1,1-dimethyl-2-butenyl, 1,1-dimethyl-3-butenyl, 1,2-dimethyl-1-butenyl, 1,2-dimethyl-2-butenyl, 1,2-dimethyl-3-butenyl, 1,3-dimethyl-1-butenyl, 1,3-dimethyl-2-butenyl, 1,3-dimethyl-3-butenyl, 2,2-dimethyl-3-butenyl, 2,3-dimethyl-1-butenyl, 2,3-dimethyl-2-butenyl, 2,3-dimethyl-3-butenyl, 3,3-dimethyl-1-butenyl, 3,3-dimethyl-2-butenyl, 1-ethyl-1-butenyl, 1-ethyl-2-butenyl, 1-ethyl-3-butenyl, 2-ethyl-1-butenyl, 2-ethyl-2-butenyl, 2-ethyl-3-butenyl, 1,1,2-trimethyl-2-propenyl, 1-ethyl-1-methyl-2-propenyl, 1-ethyl-2-methyl-1-propenyl and 1-ethyl-2-methyl-2-propenyl.

The term "C<sub>2</sub>-C<sub>m</sub>-alkynyl" as used herein refers to a branched or unbranched unsaturated hydrocarbon group having 2 to m, e.g. 2 to 10 or 2 to 6 carbon atoms and containing at least one triple bond, such as ethynyl, propynyl, 1-butyne, 2-butyne, and the like.

The term "C<sub>1</sub>-C<sub>4</sub>-alkoxy-C<sub>1</sub>-C<sub>4</sub>-alkyl" as used herein refers to alkyl having 1 to 4 carbon atoms, e.g. like specific examples mentioned above, wherein one hydrogen atom of the alkyl radical is replaced by an C<sub>1</sub>-C<sub>4</sub>-alkoxy group.

The term "C<sub>3</sub>-C<sub>m</sub>-cycloalkyl" as used herein refers to a monocyclic 3- to m-membered saturated cycloaliphatic radicals, e.g. cyclopropyl, cyclobutyl, cyclopentyl, cyclohexyl, cycloheptyl, cyclooctyl and cyclodecyl.

The term "aryl" as used herein refers to an aromatic hydrocarbon radical such as naphthyl or in particular phenyl.

5 The term "3- to 6-membered carbocyclic ring" as used herein refers to cyclopropane, cyclobutane, cyclopentane and cyclohexane rings.

10 The term "3-, 4-, 5-, 6- or 7-membered saturated, partially unsaturated or aromatic heterocyclic ring containing 1, 2 or 3 heteroatoms" or "containing heteroatom groups", wherein those heteroatom(s) (group(s)) are selected from N, O, S, NO, SO and SO<sub>2</sub> and are ring members, as used herein refers to monocyclic radicals, the monocyclic radicals being saturated, partially unsaturated or aromatic. The heterocyclic radical may be attached to the remainder of the molecule via a carbon ring member or via a nitrogen ring member.

15 Examples of 3-, 4-, 5-, 6- or 7-membered saturated heterocyclyl or heterocyclic rings include: Oxiranyl, aziridinyl, azetidiny, 2 tetrahydrofuranyl, 3-tetrahydrofuranyl, 2 tetrahydrothienyl, 3 tetrahydrothienyl, 2-pyrrolidinyl, 3-pyrrolidinyl, 3 pyrazolidinyl, 4 pyrazolidinyl, 5-pyrazolidinyl, 2 imidazolidinyl, 4 imidazolidinyl, 2-oxazolidinyl, 4-oxazolidinyl, 5 oxazolidinyl, 3-isoxazolidinyl, 4 isoxazolidinyl, 5 isoxazolidinyl, 2 thiazolidinyl, 4-thiazolidinyl, 5-thiazolidinyl, 3 isothiazolidinyl, 4-isothiazolidinyl, 5 isothiazolidinyl, 1,2,4-oxadiazolidin-3-yl, 1,2,4 oxadiazolidin 5 yl, 1,2,4-thiadiazolidin-3-yl, 1,2,4 thiadiazolidin-5-yl, 1,2,4 triazolidin-3-yl, 1,3,4-oxadiazolidin-2-yl, 1,3,4 thiadiazolidin-2-yl, 1,3,4 triazolidin-2-yl, 2-tetrahydropyranly, 4 tetrahydropyranly, 1,3-dioxan-5-yl, 1,4-dioxan-2-yl, 2-piperidinyl, 3-piperidinyl, 4-piperidinyl, 3-  
25 hexahydropyridazinyl, 4 hexahydropyridazinyl, 2-hexahydropyrimidinyl, 4-hexahydropyrimidinyl, 5 hexahydropyrimidinyl, 2-piperazinyl, 1,3,5-hexahydrotriazin-2-yl and 1,2,4 hexahydrotriazin-3-yl, 2-morpholinyl, 3-morpholinyl, 2-thiomorpholinyl, 3-thiomorpholinyl, 1-oxothiomorpholin-2-yl, 1-oxothiomorpholin-3-yl, 1,1-dioxothiomorpholin-2-yl, 1,1-dioxothiomorpholin-3-yl, hexahydroazepin-1-, -2-, -3- or -4-  
30 yl, hexahydrooxepinyl, hexahydro-1,3-diazepinyl, hexahydro-1,4-diazepinyl, hexahydro-1,3-oxazepinyl, hexahydro-1,4-oxazepinyl, hexahydro-1,3-dioxepinyl, hexahydro-1,4-dioxepinyl and the like.

Examples of 3-, 4-, 5-, 6- or 7-membered partially unsaturated heterocyclyl or heterocyclic rings include: 2,3-dihydrofur-2-yl, 2,3-dihydrofur-3-yl, 2,4-dihydrofur-2-yl, 2,4-  
35 dihydrofur-3-yl, 2,3-dihydrothien-2-yl, 2,3 dihydrothien-3-yl, 2,4 dihydrothien-2-yl, 2,4-dihydrothien-3-yl, 2-pyrrolin-2-yl, 2-pyrrolin-3-yl, 3 pyrrolin-2-yl, 3-pyrrolin-3-yl, 2-isoxazolin-3-yl, 3-isoxazolin-3-yl, 4 isoxazolin 3 yl, 2-isoxazolin-4-yl, 3-isoxazolin-4-yl, 4-isoxazolin-4-yl, 2 isoxazolin-5-yl, 3-isoxazolin-5-yl, 4-isoxazolin-5-yl, 2-isothiazolin-3-yl, 3 isothiazolin-3-yl, 4-isothiazolin-3-yl, 2-isothiazolin-4-yl, 3-isothiazolin-4-yl, 4 isothi-  
40 azolin-4-yl, 2-isothiazolin-5-yl, 3-isothiazolin-5-yl, 4-isothiazolin-5-yl, 2,3 dihydropyrazol-1-yl, 2,3-dihydropyrazol-2-yl, 2,3-dihydropyrazol-3-yl, 2,3 dihydropyrazol-4-yl, 2,3-dihydropyrazol-5-yl, 3,4-dihydropyrazol-1-yl, 3,4 dihydropyrazol-3-yl, 3,4-dihydropyrazol-4-yl, 3,4-dihydropyrazol-5-yl, 4,5 dihydropyrazol-1-yl, 4,5-

dihydropyrazol-3-yl, 4,5-dihydropyrazol-4-yl, 4,5 dihydropyrazol-5-yl, 2,3-dihydrooxazol-2-yl, 2,3-dihydrooxazol-3-yl, 2,3 dihydrooxazol-4-yl, 2,3-dihydrooxazol-5-yl, 3,4-dihydrooxazol-2-yl, 3,4 dihydrooxazol-3-yl, 3,4-dihydrooxazol-4-yl, 3,4-dihydrooxazol-5-yl, 3,4 dihydrooxazol-2-yl, 3,4-dihydrooxazol-3-yl, 3,4-dihydrooxazol-4-yl, 2-, 3-, 4-, 5- or 6-di- or tetrahydropyridinyl, 3-di- or tetrahydropyridazinyl, 4 di- or tetrahydropyridazinyl, 2-di- or tetrahydropyrimidinyl, 4-di- or tetrahydropyrimidinyl, 5 di- or tetrahydropyrimidinyl, di- or tetrahydropyrazinyl, 1,3,5-di- or tetrahydrotriazin-2-yl, 1,2,4-di- or tetrahydrotriazin-3-yl, 2,3,4,5-tetrahydro[1H]azepin-1-, -2-, -3-, -4-, -5-, -6- or -7-yl, 3,4,5,6-tetrahydro[2H]azepin-2-, -3-, -4-, -5-, -6- or -7-yl, 2,3,4,7 tetrahydro[1H]azepin-1-, -2-, -3-, -4-, -5-, -6- or -7-yl, 2,3,6,7 tetrahydro[1H]azepin-1-, -2-, -3-, -4-, -5-, -6- or -7-yl, tetrahydrooxepinyl, such as 2,3,4,5-tetrahydro[1H]oxepin-2-, -3-, -4-, -5-, -6- or -7-yl, 2,3,4,7 tetrahydro[1H]oxepin-2-, -3-, -4-, -5-, -6- or -7-yl, 2,3,6,7 tetrahydro[1H]oxepin-2-, -3-, -4-, -5-, -6- or -7-yl, tetrahydro-1,3-diazepinyl, tetrahydro-1,4-diazepinyl, tetrahydro-1,3-oxazepinyl, tetrahydro-1,4-oxazepinyl, tetrahydro-1,3-dioxepinyl and tetrahydro-1,4-dioxepinyl.

Examples of 5- or 6-membered aromatic heterocyclyl (hetaryl) or heteroaromatic rings are: 2-furyl, 3-furyl, 2-thienyl, 3-thienyl, 2-pyrrolyl, 3-pyrrolyl, 3-pyrazolyl, 4-pyrazolyl, 5-pyrazolyl, 2-oxazolyl, 4-oxazolyl, 5-oxazolyl, 2-thiazolyl, 4 thiazolyl, 5-thiazolyl, 2-imidazolyl, 4-imidazolyl, 1,3,4-triazol-2-yl, 2-pyridinyl, 3-pyridinyl, 4-pyridinyl, 3-pyridazinyl, 4-pyridazinyl, 2-pyrimidinyl, 4-pyrimidinyl, 5-pyrimidinyl and 2-pyrazinyl.

A "C<sub>2</sub>-C<sub>m</sub>-alkylene" is divalent branched or preferably unbranched saturated aliphatic chain having 2 to m, e.g. 2 to 7 carbon atoms, for example CH<sub>2</sub>CH<sub>2</sub>, -CH(CH<sub>3</sub>)-, CH<sub>2</sub>CH<sub>2</sub>CH<sub>2</sub>, CH(CH<sub>3</sub>)CH<sub>2</sub>, CH<sub>2</sub>CH(CH<sub>3</sub>), CH<sub>2</sub>CH<sub>2</sub>CH<sub>2</sub>CH<sub>2</sub>, CH<sub>2</sub>CH<sub>2</sub>CH<sub>2</sub>CH<sub>2</sub>CH<sub>2</sub>, CH<sub>2</sub>CH<sub>2</sub>CH<sub>2</sub>CH<sub>2</sub>CH<sub>2</sub>CH<sub>2</sub>, and CH<sub>2</sub>CH<sub>2</sub>CH<sub>2</sub>CH<sub>2</sub>CH<sub>2</sub>CH<sub>2</sub>CH<sub>2</sub>.

#### Preferences

Embodiments and preferred compounds of the present invention are outlined in the following paragraphs.

The remarks made below concerning preferred embodiments of the variables of the compounds of formula I, especially with respect to their substituents X, A, B, W<sup>1</sup>, W<sup>2</sup>, W<sup>3</sup>, W<sup>4</sup>, Het, R<sup>1</sup> and R<sup>2</sup> are valid both on their own and, in particular, in every possible combination with each other.

When # appears in a formula showing a preferred substructure of a compound of the present invention, it denotes the attachment bond in the remainder molecule.

Preferred are compounds of formula (I), wherein Het is selected from the group consisting of radicals of formulae Het-1 to Het-24:

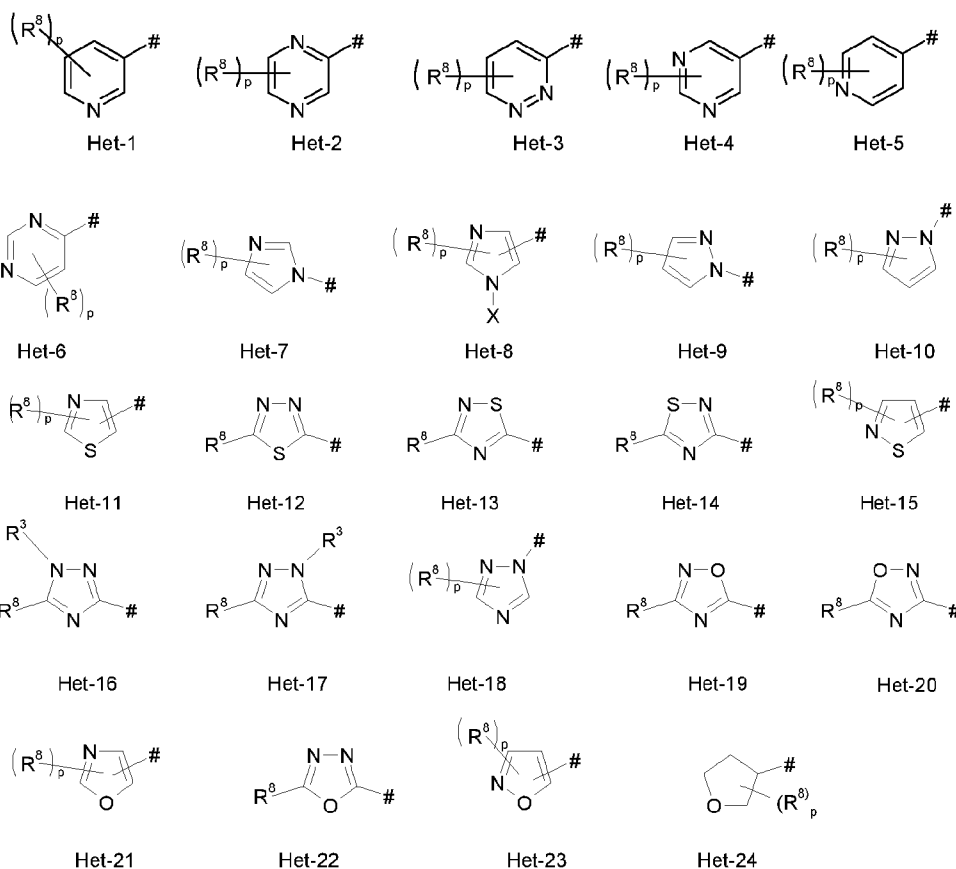

and wherein # denotes the bond in formula (I), p is 0, 1 or 2 and R<sup>8</sup> has the meaning as defined further above.

10 Especially preferred are compounds of formula (I), wherein Het is selected from the group consisting of radicals of formulae Het-1, Het-11a and Het-24:

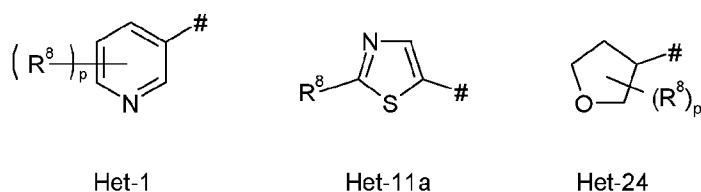

wherein R<sup>8</sup> is selected from hydrogen, halogen, C<sub>1</sub>-C<sub>4</sub>-alkoxy or C<sub>1</sub>-C<sub>4</sub>-alkyl, and where-  
 15 in the carbon atoms of the latter two radicals may be partially or fully halogenated, and p is 0, 1 or 2.

Especially more preferred are compounds of formula (I), wherein Het is Het-1a:

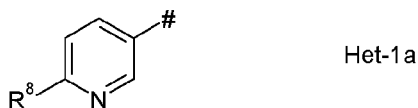

and wherein R<sup>8</sup> is as defined as further above. Preferably R<sup>8</sup> is selected from hydrogen, halogen, C<sub>1</sub>-C<sub>4</sub>-alkoxy or C<sub>1</sub>-C<sub>4</sub>-alkyl, and wherein the carbon atoms of the latter two radicals may be partially or fully halogenated.

- 5 Especially more preferred are compounds of formula (I), wherein Het is Het-11a:

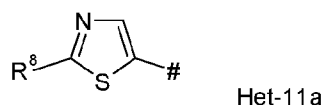

and wherein R<sup>8</sup> is as defined as further above. Preferably R<sup>8</sup> is selected from hydrogen, halogen, C<sub>1</sub>-C<sub>4</sub>-alkoxy or C<sub>1</sub>-C<sub>4</sub>-alkyl, and wherein the carbon atoms of the latter two radicals may be partially or fully halogenated.

10

Preferred are compounds of formula (I), wherein R<sup>1</sup> and R<sup>2</sup> are, independently from one another, selected from the group consisting of hydrogen, halogen, C<sub>1</sub>-C<sub>4</sub>-alkyl, C<sub>1</sub>-C<sub>4</sub>-haloalkyl and C<sub>3</sub>-C<sub>6</sub>-cycloalkyl.

- 15 Preferred are compounds of formula (I), wherein A is selected from O, S or CH=CH.

Preferred are compounds of formula (I), wherein B is N or CR<sup>7</sup>, and wherein R<sup>7</sup> is selected from the group consisting of hydrogen, halogen, C<sub>1</sub>-C<sub>4</sub>-alkyl and C<sub>1</sub>-C<sub>4</sub>-haloalkyl.

- 20 Preferred are compounds of formula (I), wherein B is CR<sup>7</sup>, and wherein R<sup>7</sup> represents a bond to the neighboring atom W<sup>1</sup> such that B and W<sup>1</sup> are connected by a double bond, and wherein W<sup>1</sup> is N or CR<sup>6</sup>, and wherein R<sup>6</sup> is selected from the group consisting of hydrogen, halogen C<sub>1</sub>-C<sub>4</sub>-alkyl and C<sub>1</sub>-C<sub>4</sub>-haloalkyl.

- 25 Preferred are compounds of formula (I), wherein W<sup>1</sup>, W<sup>2</sup>, W<sup>3</sup> and W<sup>4</sup> form together with N and B they are linked to, a saturated or unsaturated 5- or 6-membered heterocycle, wherein the group B-W<sup>1</sup>-W<sup>2</sup>-W<sup>3</sup>-W<sup>4</sup>-N together with the annulated ring forms a bicycle selected from the group of radicals of formulae II-1 to II-25:

14

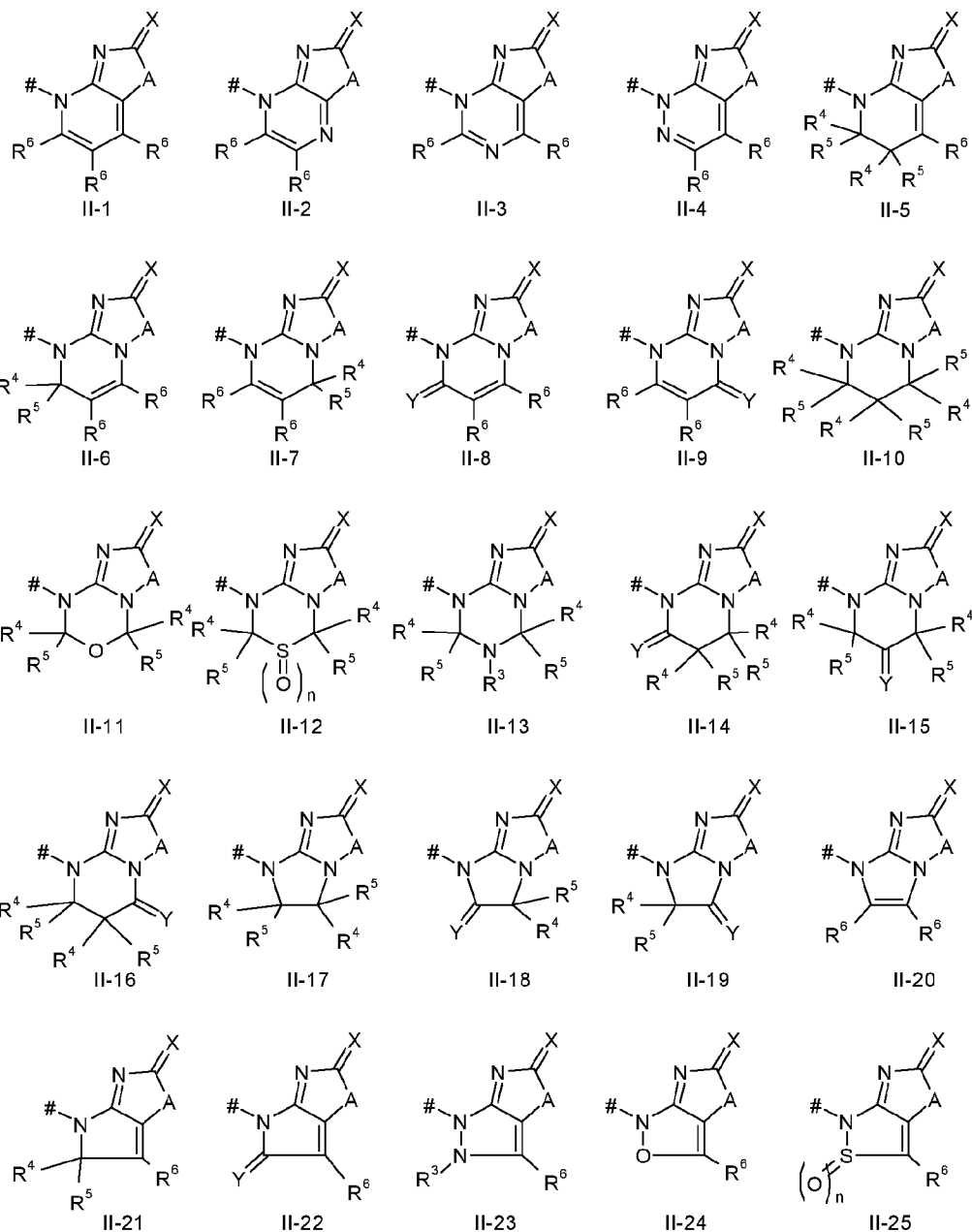

wherein R<sup>4</sup>, R<sup>5</sup> and R<sup>6</sup> are selected independently from one another from the group consisting of hydrogen, halogen, C<sub>1</sub>-C<sub>2</sub>-alkyl or C<sub>1</sub>-C<sub>2</sub>-haloalkyl and A, X, Y and R<sup>3</sup> and n are as defined further above.

5

Especially preferred are compounds of formula (I), wherein the group B-W<sup>1</sup>-W<sup>2</sup>-W<sup>3</sup>-W<sup>4</sup>-N together with the annulated ring forms a bicycle selected from the group of formulae II-1, II-2, II-5, II-6, II-7, II-10, II-17, II-20 and II-21.

15

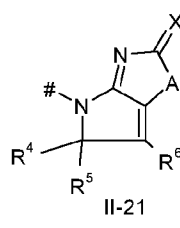
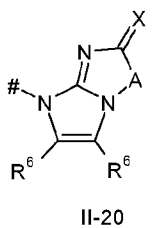
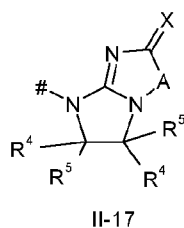
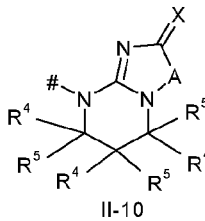
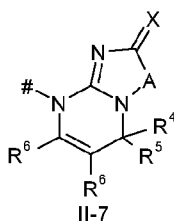
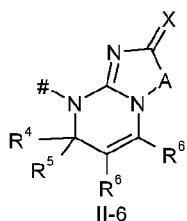
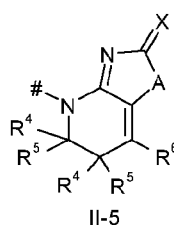
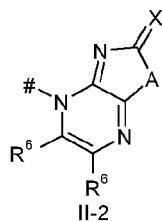
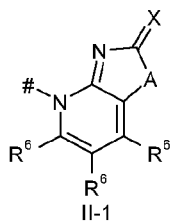

- wherein  $R^4$ ,  $R^5$  and  $R^6$  are selected preferably and independently from one another from hydrogen, halogen,  $C_1$ - $C_3$ -alkyl und  $C_1$ - $C_3$ -haloalkyl;
- 5 especially preferred  $R^4$ ,  $R^5$  and  $R^6$  are selected independently from one another from hydrogen, halogen and methyl; and
- wherein A is selected preferably from O, S or  $CH=CH$ ;
- especially preferred A is selected from O or S;
- especially more preferred A is selected from O;
- 10 especially more preferred A is selected from S; and
- wherein X is selected preferably from O or S;
- especially preferred X is selected from O;
- especially preferred X is selected from S.
- 15 Especially more preferred are compounds of formula (I), wherein the group B-W<sup>1</sup>-W<sup>2</sup>-W<sup>3</sup>-W<sup>4</sup>-N together with the annulated ring forms a bicycle radical of formulae II-1:

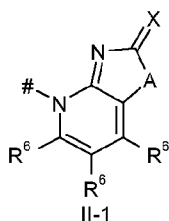

- wherein  $R^6$  is selected preferably and independently from one another from hydrogen, halogen,  $C_1$ - $C_3$ -alkyl und  $C_1$ - $C_3$ -haloalkyl;  
 especially preferred  $R^6$  is selected independently from one another from hydrogen, halogen and methyl; and
- 5 wherein A is selected preferably from O or S;  
 especially more preferred A is selected from O;  
 especially more preferred A is selected from S; and  
 wherein X is selected preferably from O or S;  
 especially preferred X is selected from O;
- 10 especially preferred X is selected from S.

Preferred are compounds of formula (I), wherein

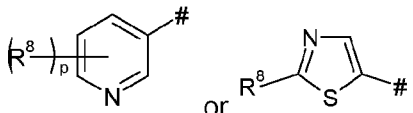
- Het is  , and wherein  $R^8$  is selected from the group consisting of halogen,  $C_1$ - $C_4$ -alkyl and  $C_1$ - $C_4$ -haloalkyl, and p is 0, 1 or 2; and
- 15 wherein A is O, S or  $CH=CH$ , X is O or S, and  $R^1$  and  $R^2$  are independently from one another selected from the group consisting of hydrogen, methyl, ethyl and trifluoromethyl, or  $R^1$  and  $R^2$  form together with the carbon atom which they are attached to, a cyclopropane ring.

- 20 Preferred are compounds of formula (I), wherein

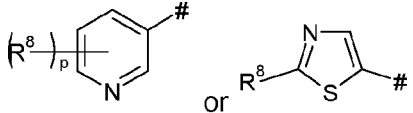
Het is  , and wherein  $R^8$  is selected from the group consisting of halogen and  $C_1$ - $C_4$ -haloalkyl, and p is 1 or 2; and  
 wherein A is O or S, X is O or S, and  $R^1$  and  $R^2$  are both hydrogen.

- 25 Examples of especially preferred compounds of formula I are given herein below.

Examples of such especially preferred compounds are compounds of formula (I-A), wherein A, X,  $R^1$ ,  $R^2$  and Het have the meanings given in any of lines 1 to 192 of table C.

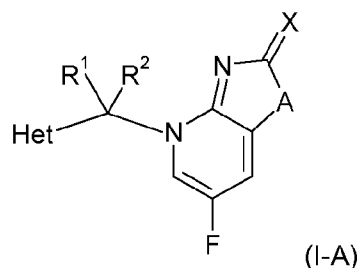

Examples of such especially preferred compounds are compounds of formula (I-B), wherein A, X, R<sup>1</sup>, R<sup>2</sup> and Het have the meanings given in any of lines 1 to 192 of table C.

5

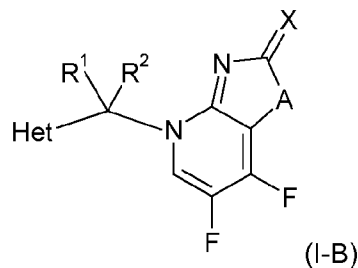

Examples of such especially preferred compounds are compounds of formula (I-C), wherein A, X, R<sup>1</sup>, R<sup>2</sup> and Het have the meanings given in any of lines 1 to 192 of table C.

10

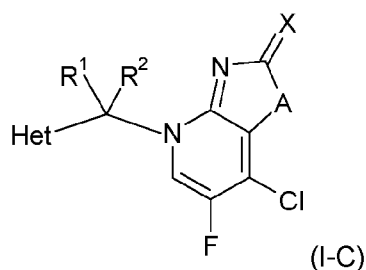

Examples of such especially preferred compounds are compounds of formula (I-D), wherein A, X, R<sup>1</sup>, R<sup>2</sup> and Het have the meanings given in any of lines 1 to 192 of table C.

15

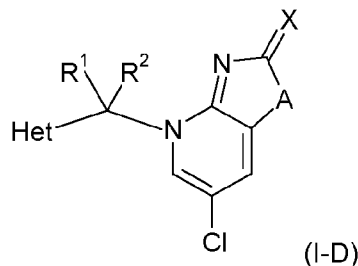

Examples of such especially preferred compounds are compounds of formula (I-E), wherein A, X, R<sup>1</sup>, R<sup>2</sup> and Het have the meanings given in any of lines 1 to 192 of table C.

20

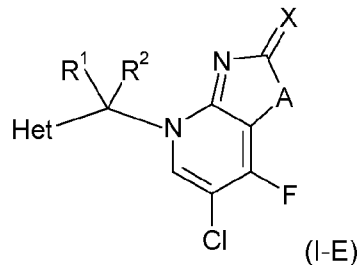

Examples of such especially preferred compounds are compounds of formula (I-F), wherein A, X, R<sup>1</sup>, R<sup>2</sup> and Het have the meanings given in any of lines 1 to 192 of table C.

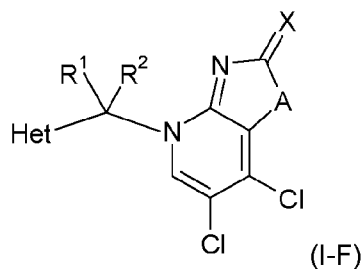

5

Examples of such especially preferred compounds are compounds of formula (I-G), wherein A, X, R<sup>1</sup>, R<sup>2</sup> and Het have the meanings given in any of lines 1 to 192 of table C.

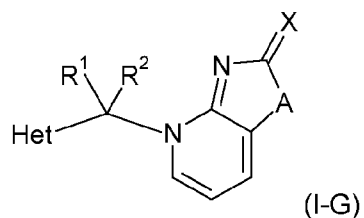

10

Examples of such especially preferred compounds are compounds of formula (I-H), wherein A, X, R<sup>1</sup>, R<sup>2</sup> and Het have the meanings given in any of lines 1 to 192 of table C.

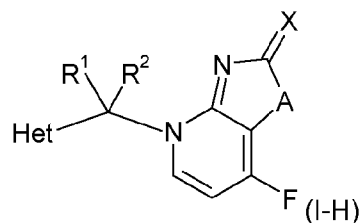

15

Examples of such especially preferred compounds are compounds of formula (I-I), wherein A, X, R<sup>1</sup>, R<sup>2</sup> and Het have the meanings given in any of lines 1 to 192 of table C.

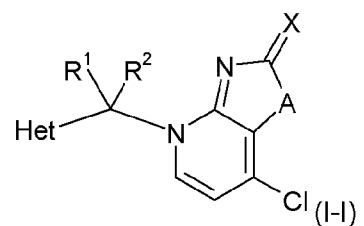

20

Examples of such especially preferred compounds are compounds of formula (I-J), wherein A, X, R<sup>1</sup>, R<sup>2</sup> and Het have the meanings given in any of lines 1 to 192 of table C.

19

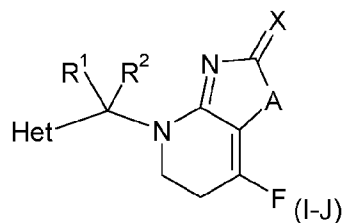

Examples of such especially preferred compounds are compounds of formula (I-K),  
 wherein A, X, R<sup>1</sup>, R<sup>2</sup> and Het have the meanings given in any of lines 1 to 192 of table  
 5 C.

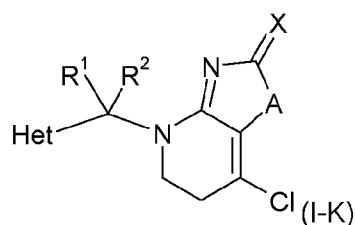

Examples of such especially preferred compounds are compounds of formula (I-L),  
 wherein A, X, R<sup>1</sup>, R<sup>2</sup> and Het have the meanings given in any of lines 1 to 192 of table  
 10 C.

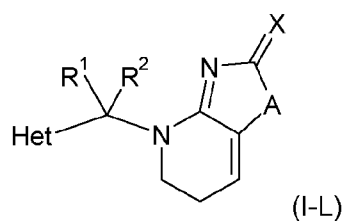

Examples of such especially preferred compounds are compounds of formula (I-M),  
 wherein A, X, R<sup>1</sup>, R<sup>2</sup> and Het have the meanings given in any of lines 1 to 192 of table  
 15 C.

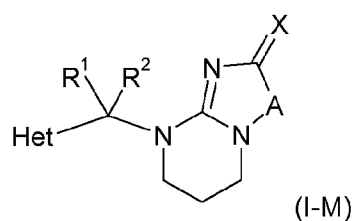

Examples of such especially preferred compounds are compounds of formula (I-N),  
 wherein A, X, R<sup>1</sup>, R<sup>2</sup> and Het have the meanings given in any of lines 1 to 192 of table  
 20 C.

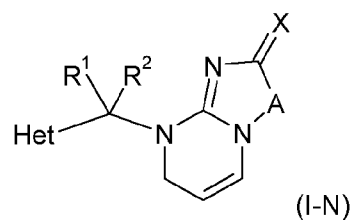

Examples of such especially preferred compounds are compounds of formula (I-O), wherein A, X, R<sup>1</sup>, R<sup>2</sup> and Het have the meanings given in any of lines 1 to 192 of table C.

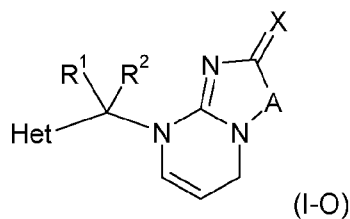

5

Examples of such especially preferred compounds are compounds of formula (I-P), wherein A, X, R<sup>1</sup>, R<sup>2</sup> and Het have the meanings given in any of lines 1 to 192 of table C.

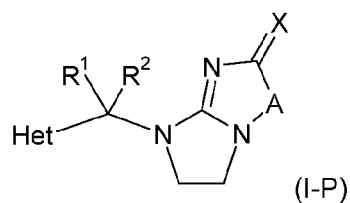

10

Examples of such especially preferred compounds are compounds of formula (I-Q), wherein A, X, R<sup>1</sup>, R<sup>2</sup> and Het have the meanings given in any of lines 1 to 192 of table C.

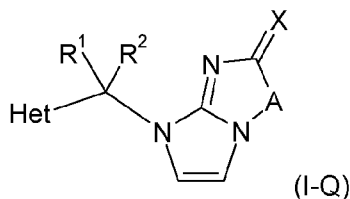

15

Examples of such especially preferred compounds are compounds of formula (I-R), wherein A, X, R<sup>1</sup>, R<sup>2</sup> and Het have the meanings given in any of lines 1 to 192 of table C.

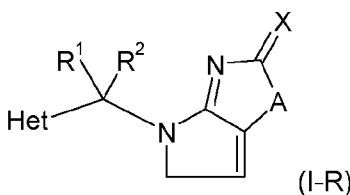

20

Table C:

Compound no.	Het	R <sup>1</sup>	R <sup>2</sup>	X	A
C.1		H	H	O	O

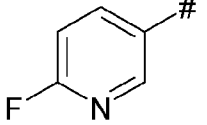
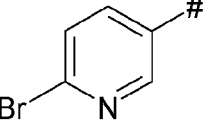
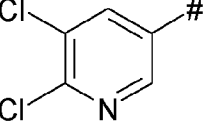
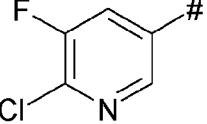
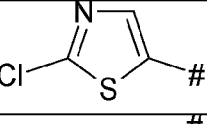
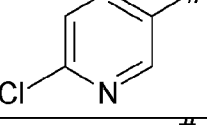
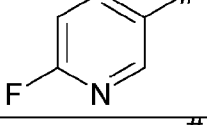
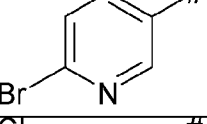
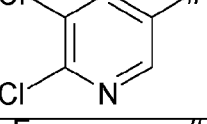
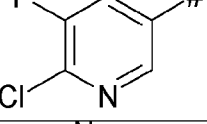
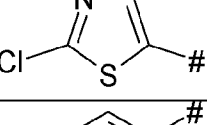
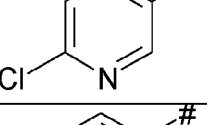
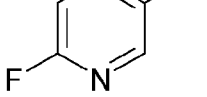
Compound no.	Het	R <sup>1</sup>	R <sup>2</sup>	X	A
C.2		H	H	O	O
C.3		H	H	O	O
C.4		H	H	O	O
C.5		H	H	O	O
C.6		H	H	O	O
C.7		H	H	O	S
C.8		H	H	O	S
C.9		H	H	O	S
C.10		H	H	O	S
C.11		H	H	O	S
C.12		H	H	O	S
C.13		H	H	S	O
C.14		H	H	S	O

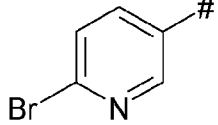
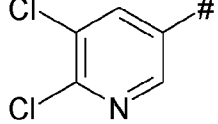
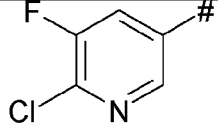
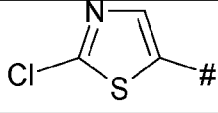
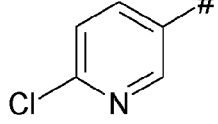
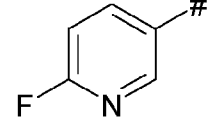
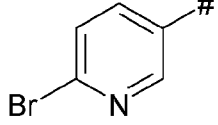
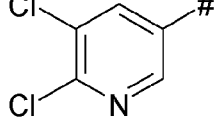
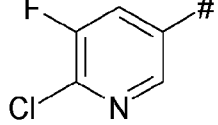
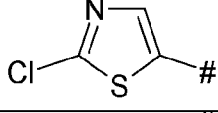
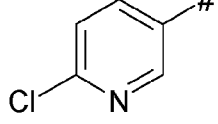
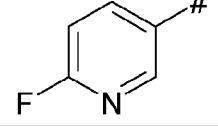
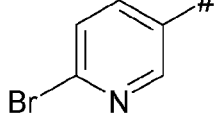
Compound no.	Het	R <sup>1</sup>	R <sup>2</sup>	X	A
C.15		H	H	S	O
C.16		H	H	S	O
C.17		H	H	S	O
C.18		H	H	S	O
C.19		H	H	S	S
C.20		H	H	S	S
C.21		H	H	S	S
C.22		H	H	S	S
C.23		H	H	S	S
C.24		H	H	S	S
C.25		CH <sub>3</sub>	H	O	O
C.26		CH <sub>3</sub>	H	O	O
C.27		CH <sub>3</sub>	H	O	O

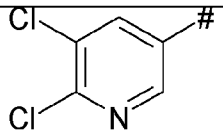
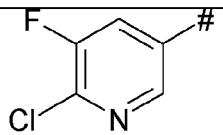
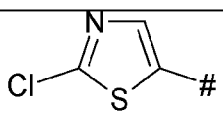
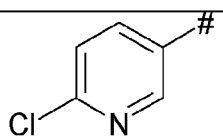
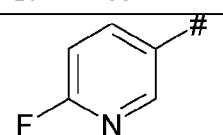
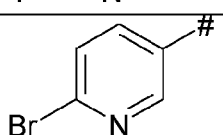
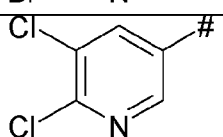
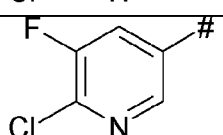
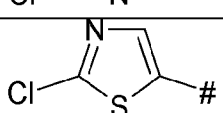
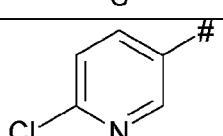
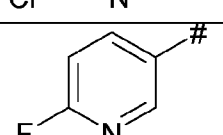
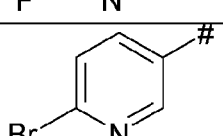
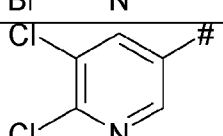
Compound no.	Het	R <sup>1</sup>	R <sup>2</sup>	X	A
C.28		CH <sub>3</sub>	H	O	O
C.29		CH <sub>3</sub>	H	O	O
C.30		CH <sub>3</sub>	H	O	O
C.31		CH <sub>3</sub>	H	O	S
C.32		CH <sub>3</sub>	H	O	S
C.33		CH <sub>3</sub>	H	O	S
C.34		CH <sub>3</sub>	H	O	S
C.35		CH <sub>3</sub>	H	O	S
C.36		CH <sub>3</sub>	H	O	S
C.37		CH <sub>3</sub>	H	S	O
C.38		CH <sub>3</sub>	H	S	O
C.39		CH <sub>3</sub>	H	S	O
C.40		CH <sub>3</sub>	H	S	O

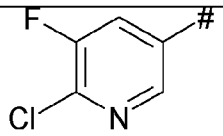
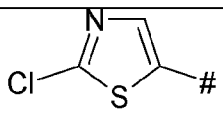
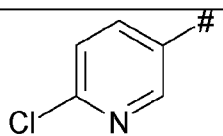
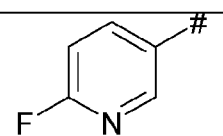
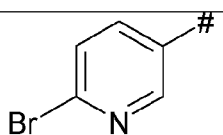
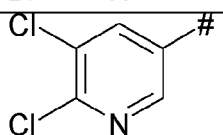
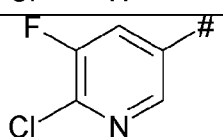
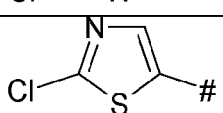
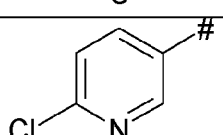
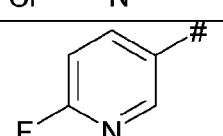
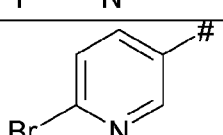
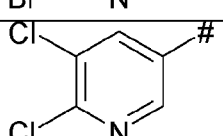
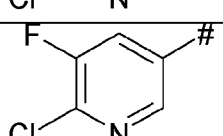
Compound no.	Het	R <sup>1</sup>	R <sup>2</sup>	X	A
C.41		CH <sub>3</sub>	H	S	O
C.42		CH <sub>3</sub>	H	S	O
C.43		CH <sub>3</sub>	H	S	S
C.44		CH <sub>3</sub>	H	S	S
C.45		CH <sub>3</sub>	H	S	S
C.46		CH <sub>3</sub>	H	S	S
C.47		CH <sub>3</sub>	H	S	S
C.48		CH <sub>3</sub>	H	S	S
C.49		H	CF <sub>3</sub>	O	O
C.50		H	CF <sub>3</sub>	O	O
C.51		H	CF <sub>3</sub>	O	O
C.52		H	CF <sub>3</sub>	O	O
C.53		H	CF <sub>3</sub>	O	O

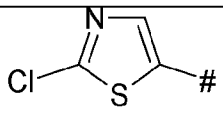
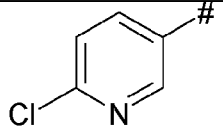
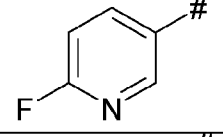
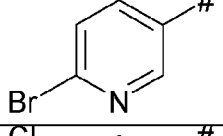
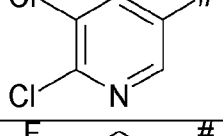
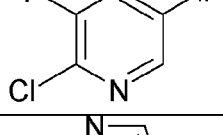
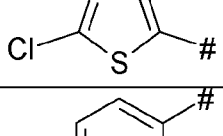
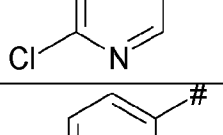
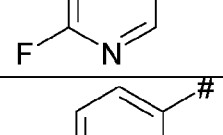
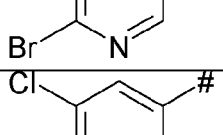
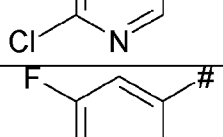
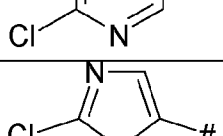
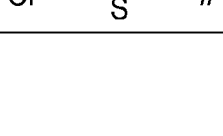
Compound no.	Het	R <sup>1</sup>	R <sup>2</sup>	X	A
C.54		H	CF <sub>3</sub>	O	O
C.55		H	CF <sub>3</sub>	O	S
C.56		H	CF <sub>3</sub>	O	S
C.57		H	CF <sub>3</sub>	O	S
C.58		H	CF <sub>3</sub>	O	S
C.59		H	CF <sub>3</sub>	O	S
C.60		H	CF <sub>3</sub>	O	S
C.61		H	CF <sub>3</sub>	S	O
C.62		H	CF <sub>3</sub>	S	O
C.63		H	CF <sub>3</sub>	S	O
C.64		H	CF <sub>3</sub>	S	O
C.65		H	CF <sub>3</sub>	S	O
C.66		H	CF <sub>3</sub>	S	O

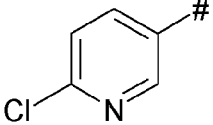
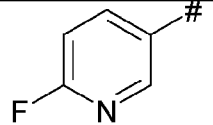
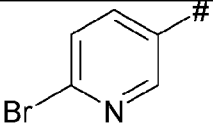
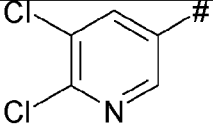
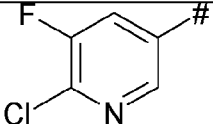
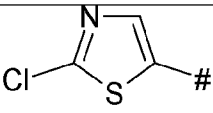
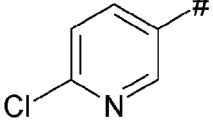
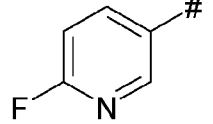
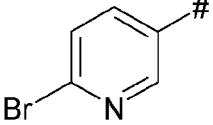
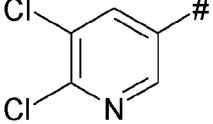
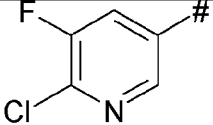
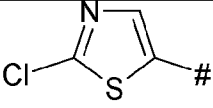
Compound no.	Het	R <sup>1</sup>	R <sup>2</sup>	X	A
C.67		H	CF <sub>3</sub>	S	S
C.68		H	CF <sub>3</sub>	S	S
C.69		H	CF <sub>3</sub>	S	S
C.70		H	CF <sub>3</sub>	S	S
C.71		H	CF <sub>3</sub>	S	S
C.72		H	CF <sub>3</sub>	S	S
C.73		H	CF <sub>3</sub>	O	O
C.74		H	CF <sub>3</sub>	O	O
C.75		H	CF <sub>3</sub>	O	O
C.76		H	CF <sub>3</sub>	O	O
C.77		H	CF <sub>3</sub>	O	O
C.78		H	CF <sub>3</sub>	O	O

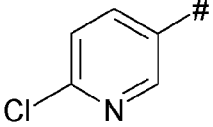
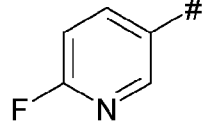
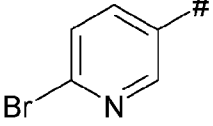
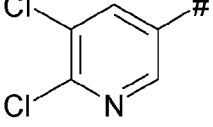
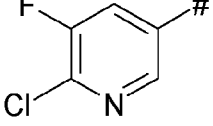
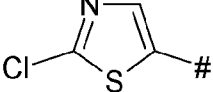
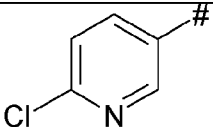
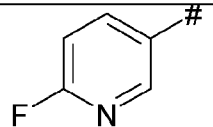
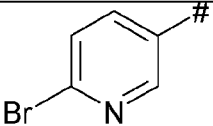
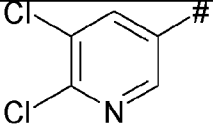
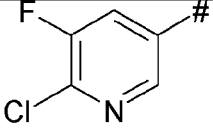
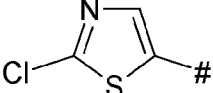
Compound no.	Het	R <sup>1</sup>	R <sup>2</sup>	X	A
C.79		H	CF <sub>3</sub>	O	S
C.80		H	CF <sub>3</sub>	O	S
C.81		H	CF <sub>3</sub>	O	S
C.82		H	CF <sub>3</sub>	O	S
C.83		H	CF <sub>3</sub>	O	S
C.84		H	CF <sub>3</sub>	O	S
C.85		H	CF <sub>3</sub>	S	O
C.86		H	CF <sub>3</sub>	S	O
C.87		H	CF <sub>3</sub>	S	O
C.88		H	CF <sub>3</sub>	S	O
C.89		H	CF <sub>3</sub>	S	O
C.90		H	CF <sub>3</sub>	S	O

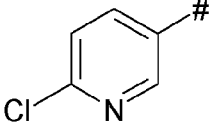
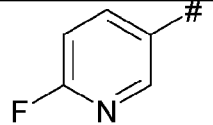
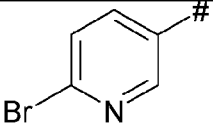
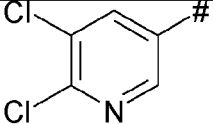
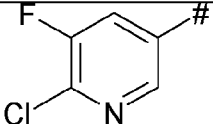
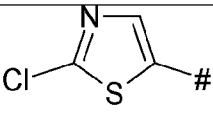
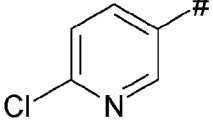
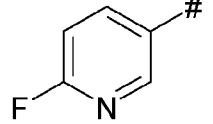
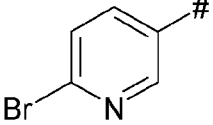
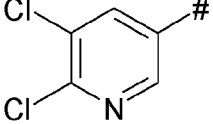
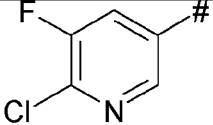
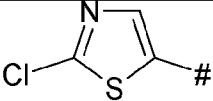
Compound no.	Het	R <sup>1</sup>	R <sup>2</sup>	X	A
C.91		H	CF <sub>3</sub>	S	S
C.92		H	CF <sub>3</sub>	S	S
C.93		H	CF <sub>3</sub>	S	S
C.94		H	CF <sub>3</sub>	S	S
C.95		H	CF <sub>3</sub>	S	S
C.96		H	CF <sub>3</sub>	S	S
C.97		CH <sub>2</sub> -CH <sub>2</sub>		O	O
C.98		CH <sub>2</sub> -CH <sub>2</sub>		O	O
C.99		CH <sub>2</sub> -CH <sub>2</sub>		O	O
C.100		CH <sub>2</sub> -CH <sub>2</sub>		O	O
C.101		CH <sub>2</sub> -CH <sub>2</sub>		O	O
C.102		CH <sub>2</sub> -CH <sub>2</sub>		O	O

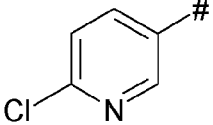
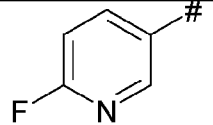
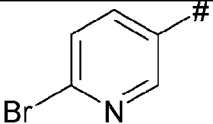
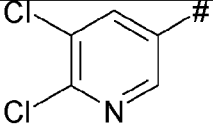
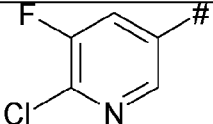
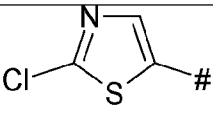
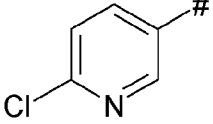
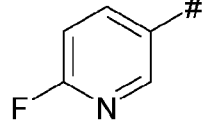
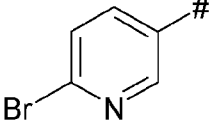
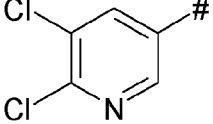
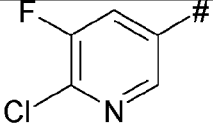
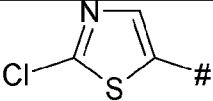
Compound no.	Het	R <sup>1</sup>	R <sup>2</sup>	X	A
C.103		CH <sub>2</sub> -CH <sub>2</sub>		O	S
C.104		CH <sub>2</sub> -CH <sub>2</sub>		O	S
C.105		CH <sub>2</sub> -CH <sub>2</sub>		O	S
C.106		CH <sub>2</sub> -CH <sub>2</sub>		O	S
C.107		CH <sub>2</sub> -CH <sub>2</sub>		O	S
C.108		CH <sub>2</sub> -CH <sub>2</sub>		O	S
C.109		CH <sub>2</sub> -CH <sub>2</sub>		S	O
C.110		CH <sub>2</sub> -CH <sub>2</sub>		S	O
C.111		CH <sub>2</sub> -CH <sub>2</sub>		S	O
C.112		CH <sub>2</sub> -CH <sub>2</sub>		S	O
C.113		CH <sub>2</sub> -CH <sub>2</sub>		S	O
C.114		CH <sub>2</sub> -CH <sub>2</sub>		S	O

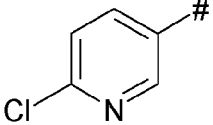
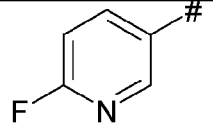
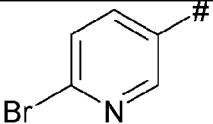
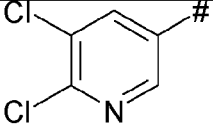
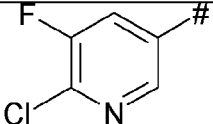
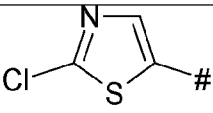
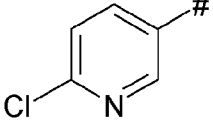
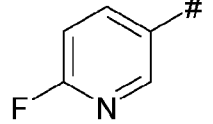
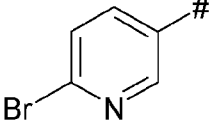
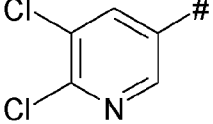
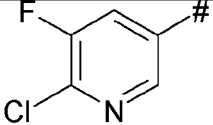
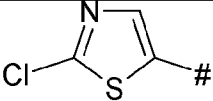
Compound no.	Het	R <sup>1</sup>	R <sup>2</sup>	X	A
C.115		CH <sub>2</sub> -CH <sub>2</sub>		S	S
C.116		CH <sub>2</sub> -CH <sub>2</sub>		S	S
C.117		CH <sub>2</sub> -CH <sub>2</sub>		S	S
C.118		CH <sub>2</sub> -CH <sub>2</sub>		S	S
C.119		CH <sub>2</sub> -CH <sub>2</sub>		S	S
C.120		CH <sub>2</sub> -CH <sub>2</sub>		S	S
C.121		CH <sub>2</sub> -CH <sub>2</sub>		O	O
C.122		CH <sub>2</sub> -CH <sub>2</sub>		O	O
C.123		CH <sub>2</sub> -CH <sub>2</sub>		O	O
C.124		CH <sub>2</sub> -CH <sub>2</sub>		O	O
C.125		CH <sub>2</sub> -CH <sub>2</sub>		O	O
C.126		CH <sub>2</sub> -CH <sub>2</sub>		O	O

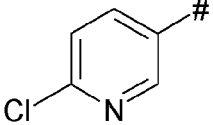
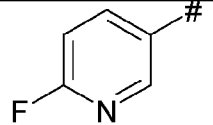
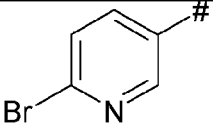
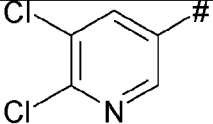
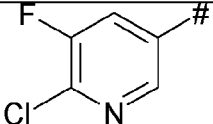
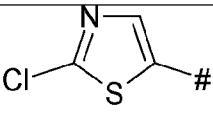
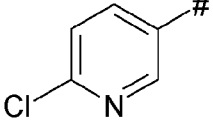
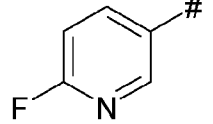
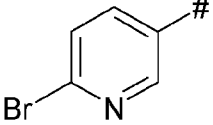
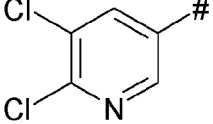
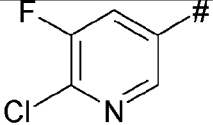
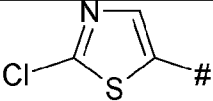
Compound no.	Het	R <sup>1</sup>	R <sup>2</sup>	X	A
C.127		CH <sub>2</sub> -CH <sub>2</sub>		O	S
C.128		CH <sub>2</sub> -CH <sub>2</sub>		O	S
C.129		CH <sub>2</sub> -CH <sub>2</sub>		O	S
C.130		CH <sub>2</sub> -CH <sub>2</sub>		O	S
C.131		CH <sub>2</sub> -CH <sub>2</sub>		O	S
C.132		CH <sub>2</sub> -CH <sub>2</sub>		O	S
C.133		CH <sub>2</sub> -CH <sub>2</sub>		S	O
C.134		CH <sub>2</sub> -CH <sub>2</sub>		S	O
C.135		CH <sub>2</sub> -CH <sub>2</sub>		S	O
C.136		CH <sub>2</sub> -CH <sub>2</sub>		S	O
C.137		CH <sub>2</sub> -CH <sub>2</sub>		S	O
C.138		CH <sub>2</sub> -CH <sub>2</sub>		S	O

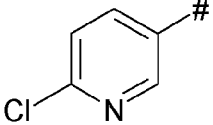
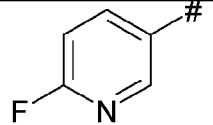
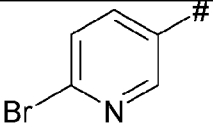
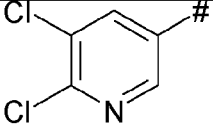
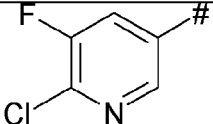
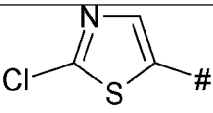
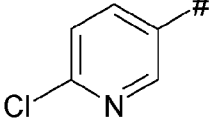
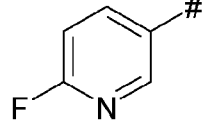
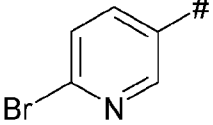
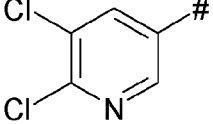
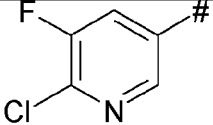
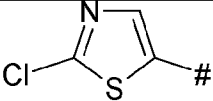
Compound no.	Het	R <sup>1</sup>	R <sup>2</sup>	X	A
C.139		CH <sub>2</sub> -CH <sub>2</sub>		S	S
C.140		CH <sub>2</sub> -CH <sub>2</sub>		S	S
C.141		CH <sub>2</sub> -CH <sub>2</sub>		S	S
C.142		CH <sub>2</sub> -CH <sub>2</sub>		S	S
C.143		CH <sub>2</sub> -CH <sub>2</sub>		S	S
C.144		CH <sub>2</sub> -CH <sub>2</sub>		S	S
C.145		CH <sub>3</sub>	CH <sub>3</sub>	O	O
C.146		CH <sub>3</sub>	CH <sub>3</sub>	O	O
C.147		CH <sub>3</sub>	CH <sub>3</sub>	O	O
C.148		CH <sub>3</sub>	CH <sub>3</sub>	O	O
C.149		CH <sub>3</sub>	CH <sub>3</sub>	O	O
C.150		CH <sub>3</sub>	CH <sub>3</sub>	O	O

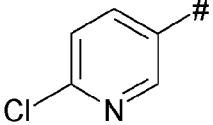
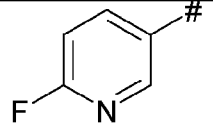
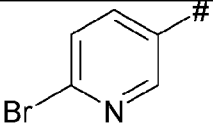
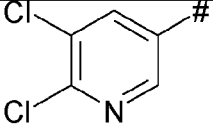
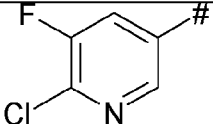
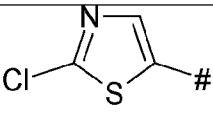
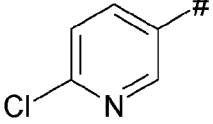
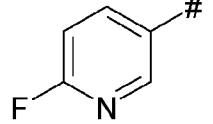
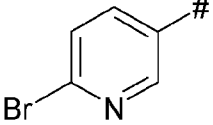
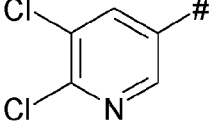
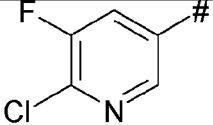
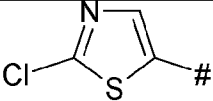
Compound no.	Het	R <sup>1</sup>	R <sup>2</sup>	X	A
C.151		CH <sub>3</sub>	CH <sub>3</sub>	O	S
C.152		CH <sub>3</sub>	CH <sub>3</sub>	O	S
C.153		CH <sub>3</sub>	CH <sub>3</sub>	O	S
C.154		CH <sub>3</sub>	CH <sub>3</sub>	O	S
C.155		CH <sub>3</sub>	CH <sub>3</sub>	O	S
C.156		CH <sub>3</sub>	CH <sub>3</sub>	O	S
C.157		CH <sub>3</sub>	CH <sub>3</sub>	S	O
C.158		CH <sub>3</sub>	CH <sub>3</sub>	S	O
C.159		CH <sub>3</sub>	CH <sub>3</sub>	S	O
C.160		CH <sub>3</sub>	CH <sub>3</sub>	S	O
C.161		CH <sub>3</sub>	CH <sub>3</sub>	S	O
C.162		CH <sub>3</sub>	CH <sub>3</sub>	S	O

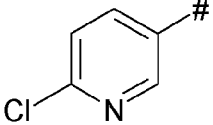
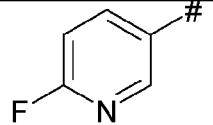
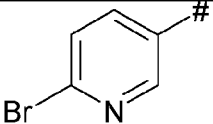
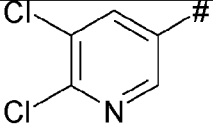
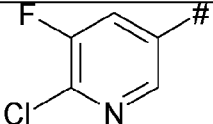
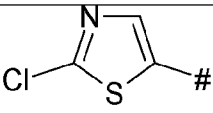
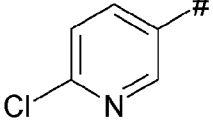
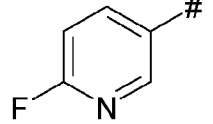
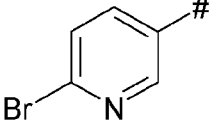
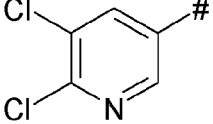
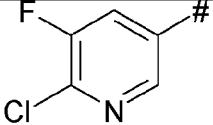
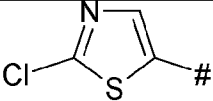
Compound no.	Het	R <sup>1</sup>	R <sup>2</sup>	X	A
C.163		CH <sub>3</sub>	CH <sub>3</sub>	S	S
C.164		CH <sub>3</sub>	CH <sub>3</sub>	S	S
C.165		CH <sub>3</sub>	CH <sub>3</sub>	S	S
C.166		CH <sub>3</sub>	CH <sub>3</sub>	S	S
C.167		CH <sub>3</sub>	CH <sub>3</sub>	S	S
C.168		CH <sub>3</sub>	CH <sub>3</sub>	S	S
C.169		CH <sub>3</sub>	CH <sub>3</sub>	O	O
C.170		CH <sub>3</sub>	CH <sub>3</sub>	O	O
C.171		CH <sub>3</sub>	CH <sub>3</sub>	O	O
C.172		CH <sub>3</sub>	CH <sub>3</sub>	O	O
C.173		CH <sub>3</sub>	CH <sub>3</sub>	O	O
C.174		CH <sub>3</sub>	CH <sub>3</sub>	O	O

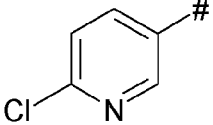
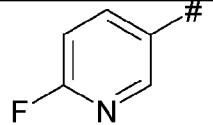
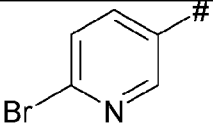
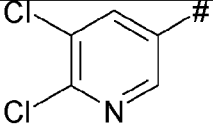
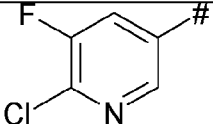
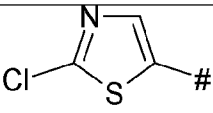
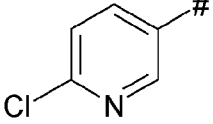
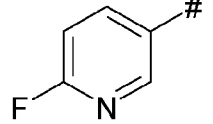
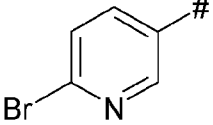
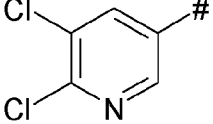
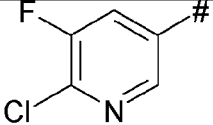
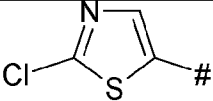
Compound no.	Het	R <sup>1</sup>	R <sup>2</sup>	X	A
C.175		CH <sub>3</sub>	CH <sub>3</sub>	O	S
C.176		CH <sub>3</sub>	CH <sub>3</sub>	O	S
C.177		CH <sub>3</sub>	CH <sub>3</sub>	O	S
C.178		CH <sub>3</sub>	CH <sub>3</sub>	O	S
C.179		CH <sub>3</sub>	CH <sub>3</sub>	O	S
C.180		CH <sub>3</sub>	CH <sub>3</sub>	O	S
C.181		CH <sub>3</sub>	CH <sub>3</sub>	S	O
C.182		CH <sub>3</sub>	CH <sub>3</sub>	S	O
C.183		CH <sub>3</sub>	CH <sub>3</sub>	S	O
C.184		CH <sub>3</sub>	CH <sub>3</sub>	S	O
C.185		CH <sub>3</sub>	CH <sub>3</sub>	S	O
C.186		CH <sub>3</sub>	CH <sub>3</sub>	S	O

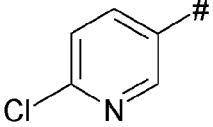
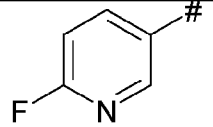
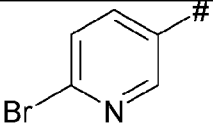
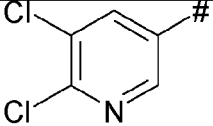
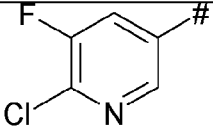
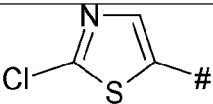
Compound no.	Het	R <sup>1</sup>	R <sup>2</sup>	X	A
C.187		CH <sub>3</sub>	CH <sub>3</sub>	S	S
C.188		CH <sub>3</sub>	CH <sub>3</sub>	S	S
C.189		CH <sub>3</sub>	CH <sub>3</sub>	S	S
C.190		CH <sub>3</sub>	CH <sub>3</sub>	S	S
C.191		CH <sub>3</sub>	CH <sub>3</sub>	S	S
C.192		CH <sub>3</sub>	CH <sub>3</sub>	S	S

Moreover, the meanings mentioned for those individual variables in the tables are per se, independently of the combination in which they are mentioned, a particularly preferred embodiment of the substituents in question.

5

#### Preparation methods

Compound of formula (I) according to the present invention can be prepared e.g. according to the preparation methods and preparation schemes as described below.

10

Compounds of formula (I) according to the present invention can be prepared by standard methods of organic chemistry e.g. by the preparation methods and preparation schemes as described below. The definitions of Het, A, B, X, R<sup>1</sup>, R<sup>2</sup>, R<sup>4</sup>, W<sup>1</sup>, W<sup>2</sup>, W<sup>3</sup> and W<sup>4</sup> of the molecular structures given in the schemes are as defined above. Room temperature means a temperature range between about 20 and 25 °C.

15

Two examples of general methods for the preparation of compounds of formula (I) are shown below in Scheme A. Thus, construction of the bicyclic structural element present in compounds of formula (I) can be achieved, for example, by intramolecular alkylation of the exocyclic amino group of precursors of formula 1. Examples of suitable leaving groups (LG) in formula 1 include, but are not limited to, halogen, alkyl sulfonate or

20

haloalkyl sulfonate. This transformation is preferably carried out in polar solvents such as acetonitrile, tetrahydrofuran or N,N-dimethylformamide in the presence of a base such as a carbonate or tertiary amine base at temperatures ranging between room temperature and the reflux temperature of the solvent.

- 5 A second synthetic route to compounds of formula (I) is the intramolecular cyclization of precursors of formula 2. Suitable leaving groups (LG) include, but are not limited to, halogen, O-alkyl or S-alkyl. The reaction is preferably carried out in an inert solvent such as toluene or xylene at temperatures ranging from room temperature to 160 °C.

10 Scheme A:

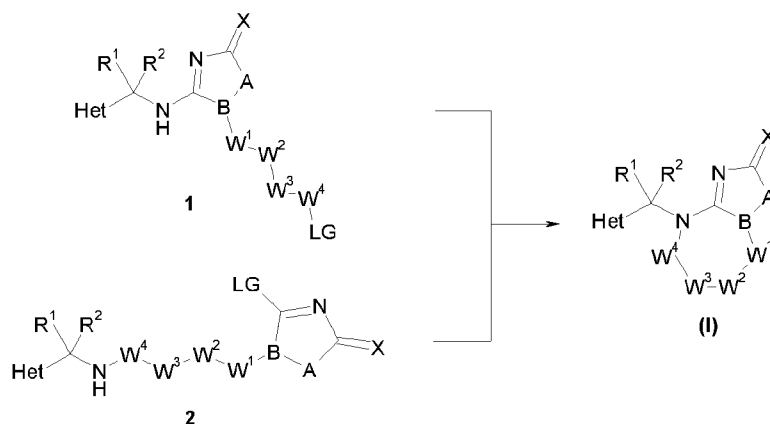

- Compounds of formula 1a, representing precursors for the synthesis of compounds of formula (I) wherein B represents N, can be prepared for example starting from S-alkyl isothiurea intermediates of formula 6 by the route shown in Scheme B. Thus, incubation of an intermediate of formula 6 with a hydroxylamine building block of formula 7 yields amino-oxadiazolones or -oxadiazolothiones of formula 8. Suitable leaving groups (LG<sup>1</sup>) in formula 6 include, but are not limited to, O-alkyl or S-alkyl. Optionally protected hydroxyl groups represent suitable groups L in formula 7; useful protecting groups (if present) include trialkylsilyl, aryl-alkyl-silyl or benzyl groups optionally carrying additional substituents. The cyclocondensation reaction is preferentially carried out in pyridine or in polar solvents such as tetrahydrofuran, dioxane or N,N-dimethylformamide in the presence of a base such as for example a tertiary amine base. Preferred temperatures for this transformation range between room temperature and about 150 °C. Compounds of formula 1a can finally be obtained from precursors of formula 8 by installation of a leaving group (LG). To this end, the (optionally protected) hydroxyl group (L) is converted into a suitable leaving group such as for example a halide, mesylate, tosylate or triflate in a sequence of deprotection (if a protecting group is present) followed by conversion to a halide or alkyl sulfonate leaving group according to standard literature procedures.

Scheme B:

38

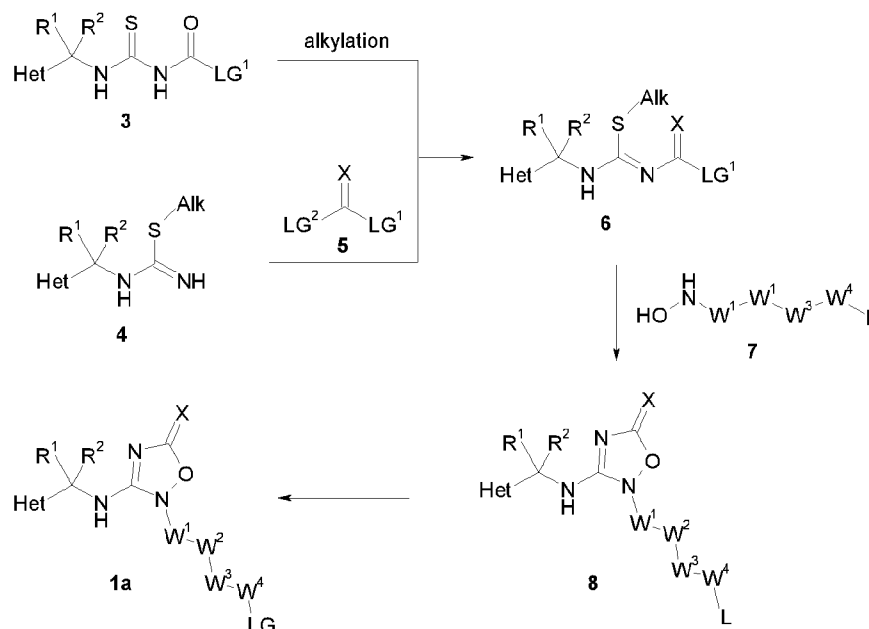

The isothiourea starting materials of formula 6 can in turn be obtained for example by regioselective S-alkylation of thiourea derivatives of formula 3 or by acylation of S-alkyl isothiourea derivatives of formula 4. For examples of representative procedures for the preparation of compounds of formulae 3 and 4, see J. Org. Chem. 2000, 65 (5), 1566-1568 and Synthesis 1988, 6, 460-466, respectively.

Preferred conditions for the alkylation of thiourea derivatives 3 include the use of polar solvents such as acetone, tetrahydrofuran or N,N-dimethylformamide in presence of a carbonate or tertiary amine base at temperatures ranging between room temperature and the boiling point of the respective solvent. A representative procedure is given in WO2008/086462. Acylation reactions of isothiourea derivatives of formula 4 using carbonyl- or thiocarbonyl reagents of formula 5 are preferably conducted in non-polar aprotic solvents such as toluene, dichloromethane or chloroform or biphasic aqueous solvent mixtures containing one of these solvents as the organic phase. Suitable reagents of formula 5 are, for example, alkyl or aryl chloroformates, dialkyl-, diaryl- or alkylaryl-carbonates and -dithiocarbonates (X represents O) and the thiocarbonyl derivatives thereof (X represents S). A preferred set of conditions for this transformation also includes the presence of a base such as a tertiary amine base for reactions carried out in organic solvents or a carbonate base for reactions carried out in biphasic solvent mixtures. Preferred temperatures range between about 0 °C and about 100 °C. Representative procedures are given in Tetrahedron Lett. 1991, 32 (7), 875-878 and Tetrahedron Lett. 2009, 50 (15), 1667-1670.

25 Scheme C:

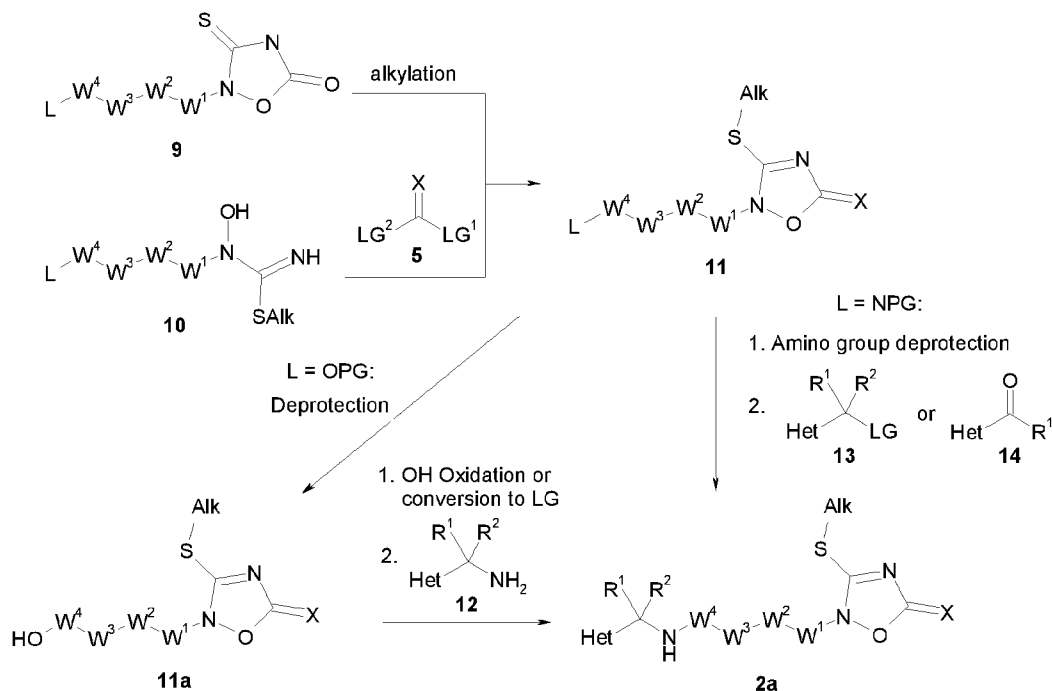

- Compounds of formula 2a, representing precursors for the synthesis of compounds of formula (I) wherein D represents N, can be prepared for example starting from 2-
- 5 substituted 3-thio-1,2,4-oxadiazolidine-3,5-dione intermediates of formula 9 or S-alkyl carbamimidothioic acid esters 10 by the route shown in Scheme C. Building blocks of formula 9 and 10 can be prepared by methods known in the art; see, for example ChemMedChem 2010, 5(1), 79-85 and B. Clement et al., Archiv der Pharmazie 1988, 321 (10), 769-770. Suitable groups L present in these starting materials are, for example, optionally protected hydroxyl or protected amino groups. Useful hydroxyl protecting groups (OPG) include trialkylsilyl, aryl-alkyl-silyl or benzyl groups optionally carrying additional substituents. Suitable amino protecting groups (NPG) include carbamates such as tert-butyl-, benzyl- or fluorenylmethyl carbamates, acetates such as trifluoroacetate or imides such as phthalimide or succinimide.
- 10 Alkylation of compounds of formula 9 using alkylating reagents such as iodomethane or iodoethane proceeds in a regioselective manner to give intermediates of formula 11. This transformation is typically carried out in a solvent such as acetone, acetonitrile or N,N-dimethylformamide in the presence of a tertiary amine or a carbonate base (such as triethyl amine or sodium carbonate, respectively) at temperatures between room
- 20 temperature and the reflux temperature of the solvent. Alternatively, compounds of formula 11 can be prepared by reaction of precursors of formula 10 with carbonyl- or thiocarbonyl reagents of formula 5. Examples of suitable reagents of formula 5 are phosgene, carbonyl diimidazole, alkyl or aryl chloroformates, dialkyl-, diaryl- or alkylaryl-carbonates and -dithiocarbonates (X represents O) and the thiocarbonyl derivatives thereof (X represents S).
- 25 Depending on the nature of the functional group L, intermediates of formula 11 can be converted to products of formula 2a following several different protocols. In cases where L represents a protected hydroxyl group, deprotection is followed by conversion

of the free OH functionality to a leaving group (such as a halide or alkyl sulfonate group) or oxidation to an aldehyde functional group and subsequent incubation with an amine of formula 12 under alkylation (L represents a leaving group) or reductive amination (L represents an aldehyde group) conditions, according to standard literature procedures. Amine building blocks of formula 12 can be prepared by methods known in the art; see, for example S. Patai "The Chemistry of the Amino Group" Interscience Publishers, New York, 1968. For compounds of formula 11 wherein L represents a protected amino group, conversion to products of formula 2a can be achieved by initial deprotection of the amino group by standard literature methods followed by incubation with electrophiles of formula 13. Suitable leaving groups (LG) include, but are not limited to, halogen, mesylate, tosylate or triflate. This transformation is typically carried out in a polar solvent such as DMF, acetonitrile or THF in the presence of a tertiary amine or carbonate base (such as triethyl amine or sodium carbonate, respectively) at temperatures ranging from room temperature to the reflux temperature of the solvent. Alternatively, compounds of formula 2a, wherein R<sup>2</sup> is H, can be obtained from compounds of formula 11 wherein L represents NH<sub>2</sub> by reaction with aldehydes or ketones of formula 14 under reductive amination conditions.

Scheme D:

20

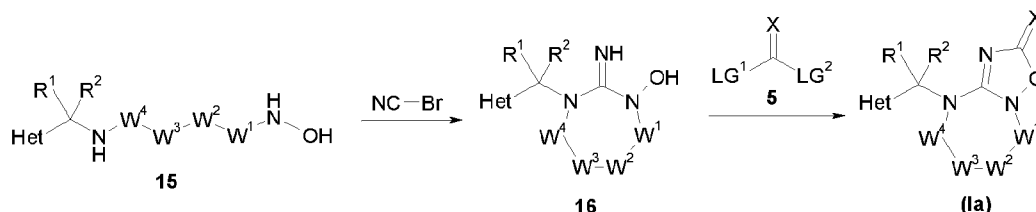

Compounds of formula (1a) representing a subset of compounds of formula (I) wherein A is O and B is N, can be prepared by the sequence of steps shown in Scheme D. Thus, cyclisation of compounds of formula 15 by reaction with cyanogen bromide or cyanogen chloride yields hydroxyguanidine intermediates of formula 16. This transformation is preferably carried out in a polar solvent such as acetonitrile or N,N-dimethylformamide at room temperature or moderately elevated temperatures in analogy to the conversion of diamines to the corresponding cyclic guanidines; see, for example, J. E. Casida et al., J. Med. Chem. 1999, 42, 2227-2234. Hydroxyguanidines of formula 16 can be converted to the corresponding bicyclic compounds of formula (1a) by incubation with a carbonylation reagent of formula 5. Examples of suitable reagents of formula 5 are phosgene, carbonyl diimidazole, alkyl or aryl chloroformates, dialkyl-, diaryl- or alkylaryl-carbonates and -dithiocarbonates (X represents O) and the thiocarbonyl derivatives thereof (X represents S). Preferred conditions for this transformation include the use of nonpolar solvents such as dichloromethane, chloroform or toluene at temperatures ranging from room temperature to the reflux temperature of the solvent. The presence of a base such a tertiary amine base is preferred if one of the leaving groups in formula 5 is halogen. Analogous carbonylation reactions of hydroxyamidine

compounds have been described for example in G. Zinner et al, *Archiv der Pharmazie* 1986, 319 (12), 1073-1079 or C.-Z. Dong et al., *Bioorg. Med. Chem.* 2005, 13 (6), 1989-2007.

## 5 Scheme E:

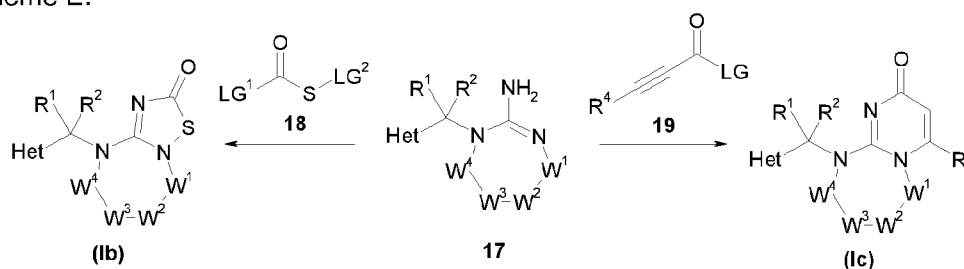

- Further useful intermediates for the synthesis of subsets of compounds of formula (I) are guanidine derivatives of formula 17. The preparation of these intermediates has been described in the literature; see, for example, J. E. Casida et al., *J. Labelled Compounds Radiopharm.* 1996, 38, 971-978 and J. E. Casida et al., *J. Med. Chem.* 1999, 42, 2227-2234. Reaction of compounds of formula 17 with an acylsulfenyl reagent of formula 18 provides bicyclic products of formula (Ib). Suitable acylsulfenyl reagents are, for example, chloroformyl sulfenyl chloride or alkyl chlorocarbonyl disulfides. Preferred conditions for this transformation include the use of aprotic solvents such as tetrahydrofuran, toluene or benzene in the presence of a base such as a tertiary amine base at temperatures between about 0 and about 100 °C. For representative procedures see, for example, K. Pilgram et al., *J. Org. Chem.* 1973, 38 (8), 1575-1578 and K. Pilgram et al., *J. Org. Chem.* 1973, 38 (8), 1578-1582.
- Compounds of formula (Ic) can be obtained from guanidines of formula 17 by reaction with a propionic acid derivative of formula 19. Suitable reagents of formula 19 include, for example, alkyl propiolates or propionyl halides. This transformation is preferably carried out in nonpolar solvents such as toluene or xylene at elevated temperatures such as the reflux temperature of the solvent. For a representative procedure, see M. A. Muniem et al., *J. Heterocycl. Chem.* 1978, 15 (5), 849-853.

## Scheme F:

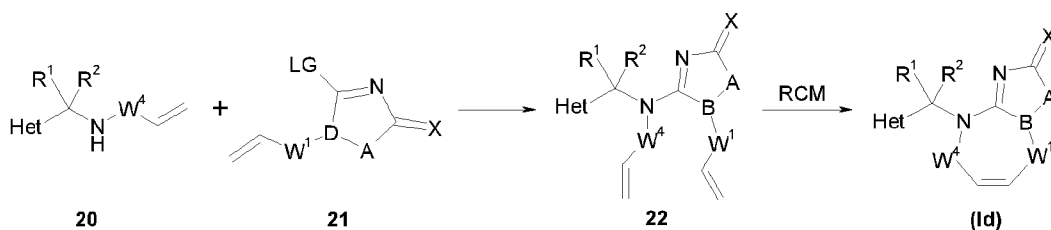

- Compounds of formula (Id) containing an unsaturated element within the bicyclic structural motif can also be prepared from precursors of formula 22 by ring closing metathesis. To this end, dienes of formula 22 are incubated with a metathesis catalyst such as, for example, the Grubbs ruthenium or Schrock molybdenum complex catalysts following procedures well known in the art (see, for example, A. Gradillas et al., *Angew.*

Chem. Int. Ed. 2006, 45 (37), 6086-6101 and references cited therein). Intermediates of formula 22 are accessible by incubation of amines of formula 20 with building blocks of formula 21, which in turn may be obtained by methods employed for the synthesis of compounds of formula 11 (Scheme C). Suitable leaving groups LG in formula 21 include S-alkyl, O-alkyl or halogen. Amines of formula 20 can be prepared by methods known in the art; see, for example S. Patai "The Chemistry of the Amino Group" Interscience Publishers, New York, 1968. The reaction of compounds 20 and 21 to give intermediate 22 is preferably carried out in a polar solvent such as tetrahydrofuran, acetonitrile or N,N-dimethylformamide in the presence of a tertiary amine or carbonate base (such as triethyl amine or sodium carbonate, respectively) at temperatures ranging from room temperature to the reflux temperature of the solvent. A representative procedure for this transformation is given in: S. Chen et al., Bioorg. Med. Chem. Lett. 2007, 17 (8), 2134-2138.

15 Scheme G:

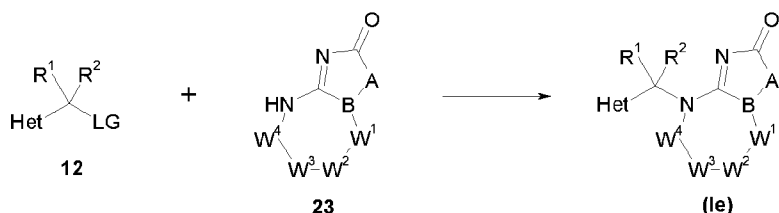

A general method for the preparation of compounds of formula (Ie) is the alkylation of bicycles of formula 23 with an electrophile of formula 13 (Scheme G). Examples of the leaving group (LG) in formula 13 include halogen, alkyl sulfonates or fluoroalkyl sulfonates. Preferably, this transformation is carried out in a polar solvent such as acetonitrile or acetone in the presence of a base such as a carbonate or tertiary amine base (such as triethyl amine or sodium carbonate, respectively) at temperatures between room temperature and the reflux temperature of the solvent. For bicycles 23 corresponding to the subset of formula (II-1) wherein A represents O, such alkylation reactions have been described, for example, in CH461489 and WO2007/022257.

Scheme H:

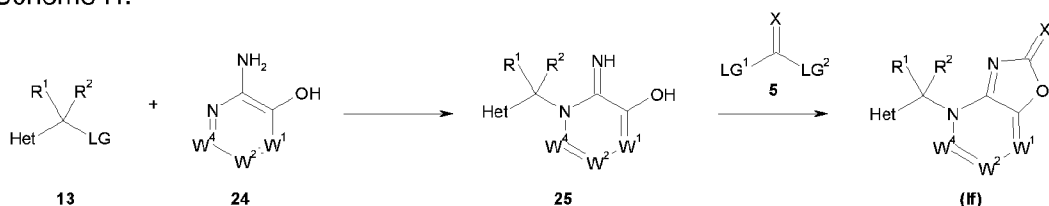

30 Compounds of formula (If) featuring a structural element representing a subset of bicycles of formulae (II-1), (II-2), (II-3) or (II-4) wherein X represents O or S, W<sup>1</sup>, W<sup>2</sup> and W<sup>4</sup> represent CR<sup>6</sup> or N can be prepared by the synthetic sequence outlined in Scheme H. Thus, N-alkylation of an amino-hydroxy-substituted aromatic heterocycle (e.g. pyridine, pyridazine, pyrimidine, pyrazine or triazine) of formula 24 with an electrophile of formula 13 (see, for example, R. C. Young et al., J. Med. Chem. 1987, 30 (7), 1150-1156), followed by reaction of the product of formula 25 with a carbonylation / thiocarbonylation reagent of formula 5 gives rise to bicycles of formula (If). Suitable

tion reagent of formula 5 gives rise to bicycles of formula (If). Suitable reagents of formula 5 are, for example, phosgene, carbonyl diimidazole, alkyl or aryl chloroformates, dialkyl-, diaryl- or alkylaryl-carbonates and -dithiocarbonates (X represents O) and the thiocarbonyl derivatives thereof (X represents S). For a representative example of a carbonylation reaction, see WO2009/023844.

Scheme I:

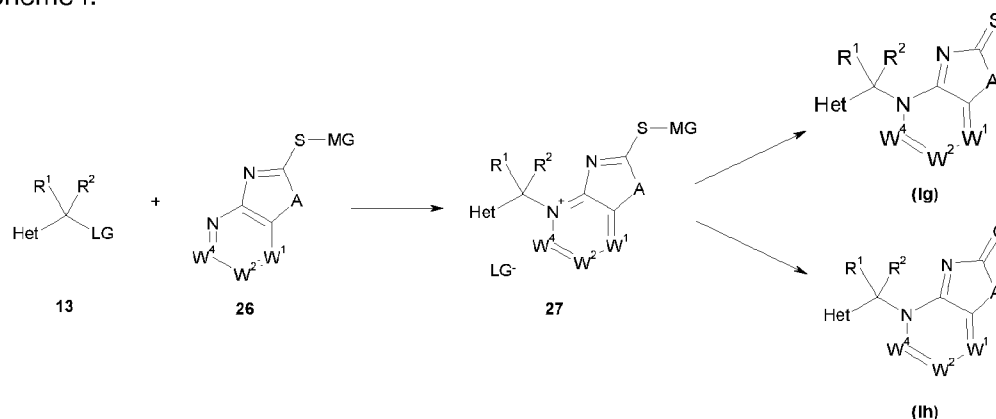

- 10 A synthetic route for the preparation of compounds of formulae (Ig) and (Ih) that takes advantage of the regioselective alkylation of thioethers of formula 26 is shown in Scheme I. For examples of this transformation, as well as of the synthesis of compounds of formula 26, see: L. Bethge et al., *Bioorg. Med. Chem.* 2008, 16 (1), 114-125; Y. Liu et al., *J. Heterocyclic Chem.* 2010, 47 (3), 683-686; WO2000/066664.
- 15 Depending on the nature of the sulfur masking group (MG), intermediates of formula 27 can be converted to products of formulae (Ig) and (Ih). For compounds of formula 27 wherein MG is a sulfur protecting group, such as, for example, (substituted) benzyl, fluorenylmethyl or methoxymethyl, deprotection of this masking group according to standard literature procedures provides compounds of formula (Ig). Alternatively,
- 20 conversion of intermediates of formula 27 to products of formula (Ig) can be achieved by incubation of 27 with a sulfide salt (such as ammonium sulfide) or H<sub>2</sub>S in a polar solvent, optionally in the presence of a base at temperatures ranging from 0 °C to the reflux temperature of the solvent. Preferred solvents are methanol, ethanol, tetrahydrofuran, N,N-dimethylformamide or pyridine.
- 25 Furthermore, compounds of formula (Ih) can be obtained from intermediates of formula 26 wherein MG denotes a (substituted) alkyl group by sulfur oxidation followed by substitution of the resulting sulfoxide or sulfone group by hydroxide. Suitable oxidants include, for example, meta-chloroperbenzoic acid, hydrogen peroxide or sodium hypochlorite. In cases where the oxidation is carried out in basic aqueous media, conversion of compounds of formula 27 to products of formula (Ih) can be achieved in one
- 30 single step.

If individual compounds cannot be prepared via the above-described routes, they can be prepared by derivatization of other compounds (I) or by customary modifications of the synthesis routes described.

- 5 The reaction mixtures are worked up in the customary manner, for example by mixing with water, separating the phases, and, if appropriate, purifying the crude products by chromatography, for example on alumina or silica gel. Some of the intermediates and end products may be obtained in the form of colorless or pale brown viscous oils, which are freed or purified from volatile components under reduced pressure and at moderately elevated temperature. If the intermediates and end products are obtained as solids, they may be purified by recrystallization or digestion.

#### Pests

- 15 The compounds of the formula I, and their salts are in particular suitable for efficiently controlling arthropodal pests such as arachnids, myriapedes and insects as well as nematodes.

The compounds of the formula I are especially suitable for efficiently combating the following pests:

- Insects from the order of the lepidopterans (*Lepidoptera*), for example *Agrotis ypsilon*, *Agrotis segetum*, *Alabama argillacea*, *Anticarsia gemmatalis*, *Argyresthia conjugella*, *Autographa gamma*, *Bupalus piniarius*, *Cacoecia murinana*, *Capua reticulana*, *Cheimatobia brumata*, *Choristoneura fumiferana*, *Choristoneura occidentalis*, *Cirphis unipuncta*, *Cydia pomonella*, *Dendrolimus pini*, *Diaphania nitidalis*, *Diatraea grandiosella*, *Earias insulana*, *Elasmopalpus lignosellus*, *Eupoecilia ambiguella*, *Evetria bouliana*, *Feltia subterranea*, *Galleria mellonella*, *Grapholitha funebrana*, *Grapholitha molesta*, *Heliothis armigera*, *Heliothis virescens*, *Heliothis zea*, *Hellula undalis*, *Hibernia defoliaria*, *Hyphantria cunea*, *Hyponomeuta malinellus*, *Keiferia lycopersicella*, *Lambdina fiscellaria*, *Laphygma exigua*, *Leucoptera coffeella*, *Leucoptera scitella*, *Lithocolletis blancardella*, *Lobesia botrana*, *Loxostege sticticalis*, *Lymantria dispar*, *Lymantria monacha*, *Lyonetia clerkella*, *Malacosoma neustria*, *Mamestra brassicae*, *Orgyia pseudotsugata*, *Ostrinia nubilalis*, *Panolis flammea*, *Pectinophora gossypiella*, *Peridroma saucia*, *Phalera bucephala*, *Phthorimaea operculella*, *Phyllocnistis citrella*, *Pieris brassicae*, *Plathypena scabra*, *Plutella xylostella*, *Pseudoplusia includens*, *Rhyacionia frustrana*, *Scrobipalpula absoluta*, *Sitotroga cerealella*, *Sparganothis pilleriana*, *Spodoptera frugiperda*, *Spodoptera littoralis*, *Spodoptera litura*, *Thaumatopoea pityocampa*, *Tortrix viridana*, *Trichoplusia ni* and *Zeiraphera canadensis*;
- beetles (*Coleoptera*), for example *Agrilus sinuatus*, *Agriotes lineatus*, *Agriotes obscurus*, *Amphimallus solstitialis*, *Anisandrus dispar*, *Anthonomus grandis*, *Anthonomus pomorum*, *Apthona euphoridae*, *Athous haemorrhoidalis*, *Atomaria linearis*, *Blastophagus piniperda*, *Blitophaga undata*, *Bruchus rufimanus*, *Bruchus pisorum*,

- gus piniperda*, *Blitophaga undata*, *Bruchus rufimanus*, *Bruchus pisorum*, *Bruchus lentis*, *Byctiscus betulae*, *Cassida nebulosa*, *Cerotoma trifurcata*, *Cetonia aurata*, *Ceuthorrhynchus assimilis*, *Ceuthorrhynchus napi*, *Chaetocnema tibialis*, *Conoderus vesperinus*, *Crioceris asparagi*, *Ctenicera ssp.*, *Diabrotica longicornis*, *Diabrotica semipunctata*, *Diabrotica 12-punctata* *Diabrotica speciosa*, *Diabrotica virgifera*, *Epilachna varivestis*, *Epitrix hirtipennis*, *Eutinobothrus brasiliensis*, *Hylobius abietis*, *Hypera brunneipennis*, *Hypera postica*, *Ips typographus*, *Lema bilineata*, *Lema melanopus*, *Leptinotarsa decemlineata*, *Limonius californicus*, *Lissorhoptrus oryzophilus*, *Melanotus communis*, *Meligethes aeneus*, *Melolontha hippocastani*, *Melolontha melolontha*, *Oulema oryzae*, *Otiorrhynchus sulcatus*, *Otiorrhynchus ovatus*, *Phaedon cochleariae*, *Phyllobius pyri*, *Phyllotreta chrysocephala*, *Phyllophaga sp.*, *Phyllopertha horticola*, *Phyllotreta nemorum*, *Phyllotreta striolata*, *Popillia japonica*, *Sitona lineatus* and *Sitophilus granaria*;
- 15 flies, mosquitoes (*Diptera*), e.g. *Aedes aegypti*, *Aedes albopictus*, *Aedes vexans*, *Anastrepha ludens*, *Anopheles maculipennis*, *Anopheles crucians*, *Anopheles albimanus*, *Anopheles gambiae*, *Anopheles freeborni*, *Anopheles leucosphyrus*, *Anopheles minimus*, *Anopheles quadrimaculatus*, *Calliphora vicina*, *Ceratitis capitata*, *Chrysomya bezziana*, *Chrysomya hominivorax*, *Chrysomya macellaria*, *Chrysops discalis*, *Chrysops silacea*, *Chrysops atlanticus*, *Cochliomyia hominivorax*, *Contarinia sorghicola* *Cordylobia anthropophaga*, *Culicoides furens*, *Culex pipiens*, *Culex nigripalpus*, *Culex quinquefasciatus*, *Culex tarsalis*, *Culiseta inornata*, *Culiseta melanura*, *Dacus cucurbitae*, *Dacus oleae*, *Dasineura brassicae*, *Delia antique*, *Delia coarctata*, *Delia platura*, *Delia radicum*, *Dermatobia hominis*, *Fannia canicularis*, *Geomyza Tripunctata*, *Gasterophilus intestinalis*, *Glossina morsitans*, *Glossina palpalis*, *Glossina fuscipes*, *Glossina tachinoides*, *Haematobia irritans*, *Haplodiplosis equestris*, *Hippelates spp.*, *Hylemyia platura*, *Hypoderma lineata*, *Leptoconops torrens*, *Liriomyza sativae*, *Liriomyza trifolii*, *Lucilia caprina*, *Lucilia cuprina*, *Lucilia sericata*, *Lycoria pectoralis*, *Mansonina titillanus*, *Mayetiola destructor*, *Musca autumnalis*, *Musca domestica*, *Muscina stabulans*, *Oestrus ovis*, *Opomyza florum*, *Oscinella frit*, *Pegomya hysocyami*, *Phorbia antiqua*, *Phorbia brassicae*, *Phorbia coarctata*, *Phlebotomus argentipes*, *Psorophora columbiae*, *Psila rosae*, *Psorophora discolor*, *Prosimulium mixtum*, *Rhagoletis cerasi*, *Rhagoletis pomonella*, *Sarcophaga haemorrhoidalis*, *Sarcophaga spp.*, *Simulium vittatum*, *Stomoxys calcitrans*, *Tabanus bovinus*, *Tabanus atratus*, *Tabanus lineola*, and *Tabanus similis*, *Tipula oleracea*, and *Tipula paludosa*;
- 20
- 25
- 30
- 35
- thrips (*Thysanoptera*), e.g. *Dichromothrips corbetti*, *Dichromothrips ssp.*, *Frankliniella fusca*, *Frankliniella occidentalis*, *Frankliniella tritici*, *Scirtothrips citri*, *Thrips oryzae*, *Thrips palmi* and *Thrips tabaci*,
- 40
- termites (*Isoptera*), e.g. *Calotermes flavicollis*, *Leucotermes flavipes*, *Heterotermes aureus*, *Reticulitermes flavipes*, *Reticulitermes virginicus*, *Reticulitermes lucifugus*, *Re-*

*ticulitermes santonensis*, *Reticulitermes grassei*, *Termes natalensis*, and *Coptotermes formosanus*;

5 cockroaches (*Blattaria* - *Blattodea*), e.g. *Blattella germanica*, *Blattella asahinae*, *Periplaneta americana*, *Periplaneta japonica*, *Periplaneta brunnea*, *Periplaneta fuliginosa*, *Periplaneta australasiae*, and *Blatta orientalis*;

10 bugs, aphids, leafhoppers, whiteflies, scale insects, cicadas (*Hemiptera*), e.g. *Acrosternum hilare*, *Blissus leucopterus*, *Cyrtopeltis notatus*, *Dysdercus cingulatus*, *Dysdercus intermedius*, *Eurygaster integriceps*, *Euschistus impictiventris*, *Leptoglossus phyllopus*, *Lygus lineolaris*, *Lygus pratensis*, *Nezara viridula*, *Piesma quadrata*, *Solubea insularis*, *Thyanta perditor*, *Acyrtosiphon onobrychis*, *Adelges laricis*, *Aphidula nasturtii*, *Aphis fabae*, *Aphis forbesi*, *Aphis pomi*, *Aphis gossypii*, *Aphis grossulariae*, *Aphis schneideri*, *Aphis spiraecola*, *Aphis sambuci*, *Acyrtosiphon pisum*, *Aulacorthum solani*, *Bemisia argentifolii*, *Brachycaudus cardui*, *Brachycaudus helichrysi*, *Brachycaudus persicae*, *Brachycaudus prunicola*, *Brevicoryne brassicae*, *Capitophorus horni*, *Cerosiphia gossypii*, *Chaetosiphon fragaefolii*, *Cryptomyzus ribis*, *Dreyfusia nordmanniana*, *Dreyfusia piceae*, *Dysaphis radicola*, *Dysaulacorthum pseudosolani*, *Dysaphis plantaginea*, *Dysaphis pyri*, *Empoasca fabae*, *Hyalopterus pruni*, *Hyperomyzus lactucae*,  
 20 *Macrosiphum avenae*, *Macrosiphum euphorbiae*, *Macrosiphon rosae*, *Megoura viciae*, *Melanaphis pyraeum*, *Metopolophium dirhodum*, *Myzus persicae*, *Myzus ascalonicus*, *Myzus cerasi*, *Myzus varians*, *Nasonovia ribis-nigri*, *Nilaparvata lugens*, *Pemphigus bursarius*, *Perkinsiella saccharicida*, *Phorodon humuli*, *Psylla mali*, *Psylla piri*, *Rhopalomyzus ascalonicus*, *Rhopalosiphum maidis*, *Rhopalosiphum padi*, *Rhopalosiphum insertum*, *Sappaphis mala*, *Sappaphis mali*, *Schizaphis graminum*, *Schizoneura lanuginosa*, *Sitobion avenae*, *Trialetrodes vaporariorum*, *Toxoptera aurantiiand*, *Viteus vitifolii*, *Cimex lectularius*, *Cimex hemipterus*, *Reduvius senilis*, *Triatoma* spp., and *Arilus critatus*;

30 ants, bees, wasps, sawflies (*Hymenoptera*), e.g. *Athalia rosae*, *Atta cephalotes*, *Atta capiguara*, *Atta cephalotes*, *Atta laevigata*, *Atta robusta*, *Atta sexdens*, *Atta texana*, *Crematogaster* spp., *Hoplocampa minuta*, *Hoplocampa testudinea*, *Lasius niger*, *Monomorium pharaonis*, *Solenopsis geminata*, *Solenopsis invicta*, *Solenopsis richteri*, *Solenopsis xyloni*, *Pogonomyrmex barbatus*, *Pogonomyrmex californicus*, *Pheidole megacephala*, *Dasymutilla occidentalis*, *Bombus* spp., *Vespula squamosa*, *Paravespula vulgaris*, *Paravespula pennsylvanica*, *Paravespula germanica*, *Dolichovespula maculata*, *Vespa crabro*, *Polistes rubiginosa*, *Camponotus floridanus*, and *Linepithema humile*;

40 crickets, grasshoppers, locusts (*Orthoptera*), e.g. *Acheta domestica*, *Gryllotalpa gryllotalpa*, *Locusta migratoria*, *Melanoplus bivittatus*, *Melanoplus femurrubrum*, *Melanoplus mexicanus*, *Melanoplus sanguinipes*, *Melanoplus spretus*, *Nomadacris septemfasciata*, *Schistocerca americana*, *Schistocerca gregaria*, *Dociostaurus maroccanus*, *Tachycines asynamorus*, *Oedaleus senegalensis*, *Zonozerus variegatus*, *Hieroglyphus daganensis*,

*Kraussaria angulifera*, *Calliptamus italicus*, *Chortoicetes terminifera*, and *Locustana pardalina*;

- arachnoidea, such as arachnids (*Acarina*), e.g. of the families Argasidae, Ixodidae and
- 5 Sarcoptidae, such as *Amblyomma americanum*, *Amblyomma variegatum*, *Amblyomma maculatum*, *Argas persicus*, *Boophilus annulatus*, *Boophilus decoloratus*, *Boophilus microplus*, *Dermacentor silvarum*, *Dermacentor andersoni*, *Dermacentor variabilis*, *Hyalomma truncatum*, *Ixodes ricinus*, *Ixodes rubicundus*, *Ixodes scapularis*, *Ixodes holocyclus*, *Ixodes pacificus*, *Ornithodoros moubata*, *Ornithodoros hermsi*, *Ornithodoros turicata*,
- 10 *Ornithonyssus bacoti*, *Otobius megnini*, *Dermanyssus gallinae*, *Psoroptes ovis*, *Rhipicephalus sanguineus*, *Rhipicephalus appendiculatus*, *Rhipicephalus evertsi*, *Sarcoptes scabiei*, and Eriophyidae spp. such as *Aculus schlechtendali*, *Phyllocoptrata oleivora* and *Eriophyes sheldoni*; Tarsonemidae spp. such as *Phytonemus pallidus* and *Polyphagotarsonemus latus*; Tenuipalpidae spp. such as *Brevipalpus phoenicis*;
- 15 Tetranychidae spp. such as *Tetranychus cinnabarinus*, *Tetranychus kanzawai*, *Tetranychus pacificus*, *Tetranychus telarius* and *Tetranychus urticae*, Panonychus ulmi, *Panonychus citri*, and *Oligonychus pratensis*; Araneida, e.g. *Latrodectus mactans*, and *Loxosceles reclusa*;
- 20 fleas (*Siphonaptera*), e.g. *Ctenocephalides felis*, *Ctenocephalides canis*, *Xenopsylla cheopis*, *Pulex irritans*, *Tunga penetrans*, and *Nosopsyllus fasciatus*,
- silverfish, firebrat (*Thysanura*), e.g. *Lepisma saccharina* and *Thermobia domestica*,
- 25 centipedes (*Chilopoda*), e.g. *Scutigera coleoptrata*,
- millipedes (*Diplopoda*), e.g. *Narceus spp.*,
- Earwigs (*Dermaptera*), e.g. *forficula auricularia*,
- 30 lice (*Phthiraptera*), e.g. *Pediculus humanus capitis*, *Pediculus humanus corporis*, *Pthirus pubis*, *Haematopinus eurytenuis*, *Haematopinus suis*, *Linognathus vituli*, *Bovicola bovis*, *Menopon gallinae*, *Menacanthus stramineus* and *Solenopotes capillatus*.
- 35 Collembola (springtails), e.g. *Onychiurus ssp.*

They are also suitable for controlling Nematodes : plant parasitic nematodes such as root knot nematodes, *Meloidogyne hapla*, *Meloidogyne incognita*, *Meloidogyne javanica*, and other *Meloidogyne* species; cyst-forming nematodes, *Globodera rostochiensis*

40 and other *Globodera* species; *Heterodera avenae*, *Heterodera glycines*, *Heterodera schachtii*, *Heterodera trifolii*, and other *Heterodera* species; Seed gall nematodes, *Anguina* species; Stem and foliar nematodes, *Aphelenchoides* species; Sting nematodes, *Belonolaimus longicaudatus* and other *Belonolaimus* species; Pine nematodes, *Bursa-*

*phelenchus xylophilus* and other Bursaphelenchus species; Ring nematodes, *Cricone-*  
*ma* species, *Criconemella* species, *Criconemoides* species, *Mesocriconema* species;  
 Stem and bulb nematodes, *Ditylenchus destructor*, *Ditylenchus dipsaci* and other *Dity-*  
*lenchus* species; Awl nematodes, *Dolichodorus* species; Spiral nematodes, *Helicoty-*  
 5 *lenchus multicinctus* and other *Helicotylenchus* species; Sheath and sheathoid nema-  
 todes, *Hemicycliophora* species and *Hemicriconemoides* species; *Hirshmanniella* spe-  
 cies; Lance nematodes, *Hoploaimus* species; false rootknot nematodes, *Nacobbus*  
 species; Needle nematodes, *Longidorus elongatus* and other *Longidorus* species; Le-  
 sion nematodes, *Pratylenchus neglectus*, *Pratylenchus penetrans*, *Pratylenchus curvi-*  
 10 *tatus*, *Pratylenchus goodeyi* and other *Pratylenchus* species; Burrowing nematodes,  
*Radopholus similis* and other *Radopholus* species; Reniform nematodes, *Rotylenchus*  
*robustus* and other *Rotylenchus* species; Scutellonema species; Stubby root nema-  
 todes, *Trichodorus primitivus* and other *Trichodorus* species, *Paratrachodorus* species;  
 Stunt nematodes, *Tylenchorhynchus claytoni*, *Tylenchorhynchus dubius* and other *Ty-*  
 15 *lenchorhynchus* species; Citrus nematodes, *Tylenchulus* species; Dagger nematodes,  
*Xiphinema* species; and other plant parasitic nematode species.

The compounds of the formula I and their salts are also useful for controlling arachnids  
 (*Arachnoidea*), such as acarians (*Acarina*), e.g. of the families *Argasidae*, *Ixodidae* and  
 20 *Sarcoptidae*, such as *Amblyomma americanum*, *Amblyomma variegatum*, *Argas persi-*  
*cus*, *Boophilus annulatus*, *Boophilus decoloratus*, *Boophilus microplus*, *Dermacentor*  
*silvarum*, *Hyalomma truncatum*, *Ixodes ricinus*, *Ixodes rubicundus*, *Ornithodoros mou-*  
*bata*, *Otobius megnini*, *Dermanyssus gallinae*, *Psoroptes ovis*, *Rhipicephalus appendi-*  
*culatus*, *Rhipicephalus evertsi*, *Sarcoptes scabiei*, and Eriophyidae spp. such as *Aculus*  
 25 *schlechtendali*, *Phyllocoptrata oleivora* and *Eriophyes sheldoni*; Tarsonemidae spp.  
 such as *Phytonemus pallidus* and *Polyphagotarsonemus latus*; Tenuipalpidae spp.  
 such as *Brevipalpus phoenicis*; Tetranychidae spp. such as *Tetranychus cinnabarinus*,  
*Tetranychus kanzawai*, *Tetranychus pacificus*, *Tetranychus telarius* and *Tetranychus*  
*urticae*, *Panonychus ulmi*, *Panonychus citri*, and *oligonychus pratensis*.

30 Compounds of the formula I are particularly useful for controlling insects, preferably  
 sucking or piercing insects such as insects from the genera Thysanoptera, Diptera and  
 Hemiptera, in particular the following species:

35 *Thysanoptera* : *Frankliniella fusca*, *Frankliniella occidentalis*, *Frankliniella tritici*, *Scirto-*  
*thrips citri*, *Thrips oryzae*, *Thrips palmi* and *Thrips tabaci*,

40 *Diptera*, e.g. *Aedes aegypti*, *Aedes albopictus*, *Aedes vexans*, *Anastrepha ludens*,  
*Anopheles maculipennis*, *Anopheles crucians*, *Anopheles albimanus*, *Anopheles gam-*  
*biae*, *Anopheles freeborni*, *Anopheles leucosphyrus*, *Anopheles minimus*, *Anopheles*  
*quadrimaculatus*, *Calliphora vicina*, *Ceratitis capitata*, *Chrysomya bezziana*, *Chryso-*  
*mya hominivorax*, *Chrysomya macellaria*, *Chrysops discalis*, *Chrysops silacea*,  
*Chrysops atlanticus*, *Cochliomyia hominivorax*, *Contarinia sorghicola* *Cordylobia an-*

*thropophaga, Culicoides furens, Culex pipiens, Culex nigripalpus, Culex quinquefasciatus, Culex tarsalis, Culiseta inornata, Culiseta melanura, Dacus cucurbitae, Dacus oleae, Dasineura brassicae, Delia antique, Delia coarctata, Delia platura, Delia radicum, Dermatobia hominis, Fannia canicularis, Geomyza Tripunctata, Gasterophilus intestinalis, Glossina morsitans, Glossina palpalis, Glossina fuscipes, Glossina tachinoides, Haematobia irritans, Haplodiplosis equestris, Hippelates spp., Hylemyia platura, Hypoderma lineata, Leptoconops torrens, Liriomyza sativae, Liriomyza trifolii, Lucilia caprina, Lucilia cuprina, Lucilia sericata, Lycoria pectoralis, Mansonia titillanus, Mayetiola destructor, Musca autumnalis, Musca domestica, Muscina stabulans, Oestrus ovis, Opomyza florum, Oscinella frit, Pegomya hysocyami, Phorbia antiqua, Phorbia brassicae, Phorbia coarctata, Phlebotomus argentipes, Psorophora columbiae, Psila rosae, Psorophora discolor, Prosimulium mixtum, Rhagoletis cerasi, Rhagoletis pomonella, Sarcophaga haemorrhoidalis, Sarcophaga spp., Simulium vittatum, Stomoxys calcitrans, Tabanus bovinus, Tabanus atratus, Tabanus lineola, and Tabanus similis, Tipula oleracea, and Tipula paludosa;*

Hemiptera, in particular aphids: *Acyrtosiphon onobrychis, Adelges laricis, Aphidula nasturtii, Aphis fabae, Aphis forbesi, Aphis pomi, Aphis gossypii, Aphis grossulariae, Aphis schneideri, Aphis spiraecola, Aphis sambuci, Acyrtosiphon pisum, Aulacorthum solani, Brachycaudus cardui, Brachycaudus helichrysi, Brachycaudus persicae, Brachycaudus prunicola, Brevicoryne brassicae, Capitophorus horni, Cerosipha gossypii, Chaetosiphon fragaefolii, Cryptomyzus ribis, Dreyfusia nordmannianae, Dreyfusia piceae, Dysaphis radicola, Dysaulacorthum pseudosolani, Dysaphis plantaginea, Dysaphis pyri, Empoasca fabae, Hyalopterus pruni, Hyperomyzus lactucae, Macrosiphum avenae, Macrosiphum euphorbiae, Macrosiphon rosae, Megoura viciae, Melanaphis pyriarius, Metopolophium dirhodum, Myzodes persicae, Myzus ascalonicus, Myzus cerasi, Myzus varians, Nasonovia ribis-nigri, Nilaparvata lugens, Pemphigus bursarius, Perkinsiella saccharicida, Phorodon humuli, Psylla mali, Psylla piri, Rhopalomyzus ascalonicus, Rhopalosiphum maidis, Rhopalosiphum padi, Rhopalosiphum insertum, Sappaphis mala, Sappaphis mali, Schizaphis graminum, Schizoneura lanuginosa, Sitobion avenae, Trialeurodes vaporariorum, Toxoptera aurantiand, and Viteus vitifolii.*

Compounds of the formula I are particularly useful for controlling insects of the orders Hemiptera and Thysanoptera.

35

#### Formulations

For use in a method according to the present invention, the compounds I can be converted into the customary formulations, e.g. solutions, emulsions, suspensions, dusts, powders, pastes, granules and directly sprayable solutions. The use form depends on the particular purpose and application method. Formulations and application methods are chosen to ensure in each case a fine and uniform distribution of the compound of the formula I according to the present invention.

40

The formulations are prepared in a known manner (see e.g. for review US 3,060,084, EP-A 707 445 (for liquid concentrates), Browning, "Agglomeration", Chemical Engineering, Dec. 4, 1967, 147-48, Perry's Chemical Engineer's Handbook, 4th Ed.,  
5 McGraw-Hill, New York, 1963, pages 8-57 and et seq. WO 91/13546, US 4,172,714, US 4,144,050, US 3,920,442, US 5,180,587, US 5,232,701, US 5,208,030, GB 2,095,558, US 3,299,566, Klingman, Weed Control as a Science, John Wiley and Sons, Inc., New York, 1961, Hance et al., Weed Control Handbook, 8th Ed., Blackwell Scientific Publications, Oxford, 1989 and Mollet, H., Grubemann, A., Formulation technology, Wiley VCH Verlag GmbH, Weinheim (Germany), 2001, 2. D. A. Knowles,  
10 Chemistry and Technology of Agrochemical Formulations, Kluwer Academic Publishers, Dordrecht, 1998 (ISBN 0-7514-0443-8), for example by extending the active compound with auxiliaries suitable for the formulation of agrochemicals, such as solvents and/or carriers, if desired emulsifiers, surfactants and dispersants, preservatives, anti-foaming agents, anti-freezing agents, for seed treatment formulation also optionally  
15 colorants and/or binders and/or gelling agents.

Solvents/carriers, which are suitable, are e.g.:

- 20 - solvents such as water, aromatic solvents (for example Solvesso products, xylene and the like), paraffins (for example mineral fractions), alcohols (for example methanol, butanol, pentanol, benzyl alcohol), ketones (for example cyclohexanone, gamma-butyrolactone), pyrrolidones (N-methyl-pyrrolidone (NMP), N-octylpyrrolidone NOP), acetates (glycol diacetate), alkyl lactates, lactones such  
25 as gamma-butyrolactone, glycols, fatty acid dimethylamides, fatty acids and fatty acid esters, triglycerides, oils of vegetable or animal origin and modified oils such as alkylated plant oils. In principle, solvent mixtures may also be used.
- carriers such as ground natural minerals and ground synthetic minerals, such as silica gels, finely divided silicic acid, silicates, talc, kaolin, attaclay, limestone,  
30 lime, chalk, bole, loess, clay, dolomite, diatomaceous earth, calcium sulfate and magnesium sulfate, magnesium oxide, ground synthetic materials, fertilizers, such as, for example, ammonium sulfate, ammonium phosphate, ammonium nitrate, ureas and products of vegetable origin, such as cereal meal, tree bark meal, wood meal and nutshell meal, cellulose powders and other solid carriers.

35

Suitable emulsifiers are nonionic and anionic emulsifiers (for example polyoxyethylene fatty alcohol ethers, alkylsulfonates and arylsulfonates).

Examples of dispersants are lignin-sulfite waste liquors and methylcellulose.

40

Suitable surfactants are alkali metal, alkaline earth metal and ammonium salts of lignosulfonic acid, naphthalenesulfonic acid, phenolsulfonic acid, dibutyl-naphthalenesulfonic acid, alkylarylsulfonates, alkyl sulfates, alkylsulfonates, fatty

alcohol sulfates, fatty acids and sulfated fatty alcohol glycol ethers, furthermore condensates of sulfonated naphthalene and naphthalene derivatives with formaldehyde, condensates of naphthalene or of naphthalenesulfonic acid with phenol and formaldehyde, polyoxyethylene octylphenyl ether, ethoxylated isooctylphenol, 5 octylphenol, nonylphenol, alkylphenyl polyglycol ethers, tributylphenyl polyglycol ether, tristearylphenyl polyglycol ether, alkylaryl polyether alcohols, alcohol and fatty alcohol/ethylene oxide condensates, ethoxylated castor oil, polyoxyethylene alkyl ethers, ethoxylated polyoxypropylene, lauryl alcohol polyglycol ether acetal, sorbitol esters,

10

Also anti-freezing agents such as glycerin, ethylene glycol, propylene glycol and bactericides such as can be added to the formulation.

15

Suitable antifoaming agents are for example antifoaming agents based on silicon or magnesium stearate.

Suitable preservatives are for example dichlorophen und benzyl alcohol hemiformal

20

Suitable thickeners are compounds which confer a pseudoplastic flow behavior to the formulation, i.e. high viscosity at rest and low viscosity in the agitated stage. Mention may be made, in this context, for example, of commercial thickeners based on polysaccharides, such as Xanthan Gum® (Kelzan® from Kelco), Rhodopol®23 (Rhone Poulenc) or Veegum® (from R.T. Vanderbilt), or organic phyllosilicates, such as Attaclay® (from Engelhardt). Antifoam agents suitable for the dispersions according to the invention are, for example, silicone emulsions (such as, for example, Silikon® SRE, Wacker or Rhodorsil® from Rhodia), long-chain alcohols, fatty acids, organofluorine compounds and mixtures thereof. Biocides can be added to stabilize the compositions according to the invention against attack by microorganisms. Suitable biocides are, for example, based on isothiazolones such as the compounds marketed under the trademarks 25 Proxel® from Avecia (or Arch) or Acticide® RS from Thor Chemie and Kathon® MK from Rohm & Haas. Suitable antifreeze agents are organic polyols, for example ethylene glycol, propylene glycol or glycerol. These are usually employed in amounts of not more than 10% by weight, based on the total weight of the active compound composition. If appropriate, the active compound compositions according to the invention may 35 comprise 1 to 5% by weight of buffer, based on the total amount of the formulation prepared, to regulate the pH, the amount and type of the buffer used depending on the chemical properties of the active compound or the active compounds. Examples of buffers are alkali metal salts of weak inorganic or organic acids, such as, for example, phosphoric acid, boronic acid, acetic acid, propionic acid, citric acid, fumaric acid, tartaric acid, oxalic acid and succinic acid. 40

Substances which are suitable for the preparation of directly sprayable solutions, emulsions, pastes or oil dispersions are mineral oil fractions of medium to high boiling point,

such as kerosene or diesel oil, furthermore coal tar oils and oils of vegetable or animal origin, aliphatic, cyclic and aromatic hydrocarbons, for example toluene, xylene, paraffin, tetrahydronaphthalene, alkylated naphthalenes or their derivatives, methanol, ethanol, propanol, butanol, cyclohexanol, cyclohexanone, isophorone, strongly polar solvents, for example dimethyl sulfoxide, N-methylpyrrolidone and water.

Powders, materials for spreading and dusts can be prepared by mixing or concomitantly grinding the active substances with a solid carrier.

Granules, for example coated granules, impregnated granules and homogeneous granules, can be prepared by binding the active ingredients to solid carriers. Examples of solid carriers are mineral earths such as silica gels, silicates, talc, kaolin, attaclay, limestone, lime, chalk, bole, loess, clay, dolomite, diatomaceous earth, calcium sulfate, magnesium sulfate, magnesium oxide, ground synthetic materials, fertilizers, such as, for example, ammonium sulfate, ammonium phosphate, ammonium nitrate, ureas, and products of vegetable origin, such as cereal meal, tree bark meal, wood meal and nut-shell meal, cellulose powders and other solid carriers.

In general, the formulations comprise from 0.01 to 95% by weight, preferably from 0.1 to 90% by weight, of the active ingredient. The active ingredients are employed in a purity of from 90% to 100%, preferably 95% to 100% (according to NMR spectrum).

For seed treatment purposes, respective formulations can be diluted 2-10 fold leading to concentrations in the ready to use preparations of 0,01 to 60% by weight active compound by weight, preferably 0,1 to 40% by weight.

The compound of formula I can be used as such, in the form of their formulations or the use forms prepared therefrom, for example in the form of directly sprayable solutions, powders, suspensions or dispersions, emulsions, oil dispersions, pastes, dustable products, materials for spreading, or granules, by means of spraying, atomizing, dusting, spreading or pouring. The use forms depend entirely on the intended purposes; they are intended to ensure in each case the finest possible distribution of the active compounds according to the invention.

The following are examples of formulations:

1. Products for dilution with water. For seed treatment purposes, such products may be applied to the seed diluted or undiluted.
- A) Water-soluble concentrates (SL, LS)

10 parts by weight of the active compound is dissolved in 90 parts by weight of water or a water-soluble solvent. As an alternative, wetters or other auxiliaries are added. The

active compound dissolves upon dilution with water, whereby a formulation with 10 % (w/w) of active compound is obtained.

B) Dispersible concentrates (DC)

5

20 parts by weight of the active compound is dissolved in 70 parts by weight of cyclohexanone with addition of 10 parts by weight of a dispersant, for example polyvinylpyrrolidone. Dilution with water gives a dispersion, whereby a formulation with 20% (w/w) of active compounds is obtained.

10

C) Emulsifiable concentrates (EC)

15 parts by weight of the active compounds is dissolved in 7 parts by weight of xylene with addition of calcium dodecylbenzenesulfonate and castor oil ethoxylate (in each case 5 parts by weight). Dilution with water gives an emulsion, whereby a formulation with 15% (w/w) of active compounds is obtained.

15

D) Emulsions (EW, EO, ES)

20 25 parts by weight of the active compound is dissolved in 35 parts by weight of xylene with addition of calcium dodecylbenzenesulfonate and castor oil ethoxylate (in each case 5 parts by weight). This mixture is introduced into 30 parts by weight of water by means of an emulsifier machine (e.g. Ultraturrax) and made into a homogeneous emulsion. Dilution with water gives an emulsion, whereby a formulation with 25% (w/w) of active compound is obtained.

25

E) Suspensions (SC, OD, FS)

In an agitated ball mill, 20 parts by weight of the active compound is comminuted with addition of 10 parts by weight of dispersants, wetters and 70 parts by weight of water or of an organic solvent to give a fine active compound suspension. Dilution with water gives a stable suspension of the active compound, whereby a formulation with 20% (w/w) of active compound is obtained.

30

35 F) Water-dispersible granules and water-soluble granules (WG, SG)

50 parts by weight of the active compound is ground finely with addition of 50 parts by weight of dispersants and wetters and made as water-dispersible or water-soluble granules by means of technical appliances (for example extrusion, spray tower, fluidized bed). Dilution with water gives a stable dispersion or solution of the active compound, whereby a formulation with 50% (w/w) of active compound is obtained.

40

G) Water-dispersible powders and water-soluble powders (WP, SP, SS, WS)

75 parts by weight of the active compound are ground in a rotor-stator mill with addition of 25 parts by weight of dispersants, wetters and silica gel. Dilution with water gives a stable dispersion or solution of the active compound, whereby a formulation with 75%  
5 (w/w) of active compound is obtained.

H) Gel-Formulation (GF)

10 In an agitated ball mill, 20 parts by weight of the active compound is comminuted with addition of 10 parts by weight of dispersants, 1 part by weight of a gelling agent wetters and 70 parts by weight of water or of an organic solvent to give a fine active compound suspension. Dilution with water gives a stable suspension of the active compound, whereby a formulation with 20% (w/w) of active compound is obtained.

15 2. Products to be applied undiluted for foliar applications. For seed treatment purposes, such products may be applied to the seed diluted or undiluted.

I) Dustable powders (DP, DS)

20 5 parts by weight of the active compound are ground finely and mixed intimately with 95 parts by weight of finely divided kaolin. This gives a dustable product having 5% (w/w) of active compound.

J) Granules (GR, FG, GG, MG)

25 0.5 part by weight of the active compound is ground finely and associated with 95.5 parts by weight of carriers, whereby a formulation with 0.5% (w/w) of active compound is obtained. Current methods are extrusion, spray-drying or the fluidized bed. This gives granules to be applied undiluted for foliar use.

30

K) ULV solutions (UL)

10 parts by weight of the active compound is dissolved in 90 parts by weight of an organic solvent, for example xylene. This gives a product having 10% (w/w) of active  
35 compound, which is applied undiluted for foliar use.

Aqueous use forms can be prepared from emulsion concentrates, pastes or wettable powders (sprayable powders, oil dispersions) by adding water. To prepare emulsions, pastes or oil dispersions, the substances, as such or dissolved in an oil or solvent, can  
40 be homogenized in water by means of a wetter, tackifier, dispersant or emulsifier. Alternatively, it is possible to prepare concentrates composed of active substance, wetter, tackifier, dispersant or emulsifier and, if appropriate, solvent or oil, and such concentrates are suitable for dilution with water.

The active ingredient concentrations in the ready-to-use products can be varied within relatively wide ranges. In general, they are from 0.0001 to 10%, preferably from 0.01 to 1%.

5

The active ingredients may also be used successfully in the ultra-low-volume process (ULV), it being possible to apply formulations comprising over 95% by weight of active ingredient, or even to apply the active ingredient without additives.

- 10 In the method of this invention compounds I may be applied with other active ingredients, for example with other pesticides, insecticides, herbicides, fertilizers such as ammonium nitrate, urea, potash, and superphosphate, phytotoxicants and plant growth regulators, safeners and nematicides. These additional ingredients may be used sequentially or in combination with the above-described compositions, if
- 15 appropriate also added only immediately prior to use (tank mix). For example, the plant(s) may be sprayed with a composition of this invention either before or after being treated with other active ingredients.

- 20 The following list M of pesticides together with which the compounds according to the invention can be used and with which potential synergistic effects might be produced, is intended to illustrate the possible combinations, but not to impose any limitation:

- M.1 Acetylcholine esterase (AChE) inhibitors from the class of
- M.1A carbamates, for example aldicarb, alanycarb, bendiocarb, benfuracarb, butocarboxim, butoxycarboxim, carbaryl, carbofuran, carbosulfan, ethiofencarb, fenobucarb, 25 formetanate, furathiocarb, isoprocarb, methiocarb, methomyl, metolcarb, oxamyl, pirimicarb, propoxur, thiodicarb, thiofanox, trimethacarb, XMC, xylycarb and triazamate; or from the class of
- M.1B organophosphates, for example acephate, azamethiphos, azinphos-ethyl, azinphosmethyl, cadusafos, chlorethoxyfos, chlorfenvinphos, chlormephos, chlorpyrifos, chlorpyrifos-methyl, coumaphos, cyanophos, demeton-S-methyl, diazinon, dichlorvos/DDVP, dicrotophos, dimethoate, dimethylvinphos, disulfoton, EPN, ethion, ethoprophos, famphur, fenamiphos, fenitrothion, fenthion, fosthiazate, heptenophos, imicyafos, isofenphos, isopropyl O- (methoxyaminothio-phosphoryl) salicylate, isoxathion, malathion, mecarbam, methamidophos, methidathion, mevinphos, monocrotophos, naled, 35 omethoate, oxydemeton-methyl, parathion, parathion-methyl, phenthoate, phorate, phosalone, phosmet, phosphamidon, phoxim, pirimiphos-methyl, profenofos, prope-tamphos, prothiofos, pyraclofos, pyridaphenthion, quinalphos, sulfotep, tebupirimfos, temephos, terbufos, tetrachlorvinphos, thiometon, triazophos, trichlorfon and vamido-
- 40 thion;

M.2. GABA-gated chloride channel antagonists such as:

- M.2A cyclodiene organochlorine compounds, as for example endosulfan or chlordane;  
or  
M.2B fiproles (phenylpyrazoles), as for example ethiprole, fipronil, flufiprole, pyrafluprole and pyriprole;
- 5
- M.3 Sodium channel modulators from the class of  
M.3A pyrethroids, for example acrinathrin, allethrin, d-cis-trans allethrin, d-trans allethrin, bifenthrin, bioallethrin, bioallethrin S-cyclopentenyl, bioresmethrin, cycloprothrin, cyfluthrin, beta-cyfluthrin, cyhalothrin, lambda-cyhalothrin, gamma-cyhalothrin, cypermethrin, alpha-cypermethrin, beta-cypermethrin, theta-cypermethrin,  
10 zeta-cypermethrin, cyphenothrin, deltamethrin, empenthrin, esfenvalerate, etofenprox, fenpropathrin, fenvalerate, flucythrinate, flumethrin, tau-fluvalinate, halfenprox, imiprothrin, meperfluthrin, metofluthrin, permethrin, phenothrin, prallethrin, profluthrin, pyrethrin (pyrethrum), resmethrin, silafluofen, tefluthrin, tetramethylfluthrin,  
15 tetramethrin, tralomethrin and transfluthrin; or  
M.3B sodium channel modulators such as DDT or methoxychlor;
- M.4 Nicotinic acetylcholine receptor agonists (nAChR) from the class of  
M.4A neonicotinoids, for example acetamiprid, clothianidin, dinotefuran, imidacloprid,  
20 nitenpyram, thiacloprid and thiamethoxam; or M.4B nicotine.
- M.5 Nicotinic acetylcholine receptor allosteric activators from the class of spinosyns, for example spinosad or spinetoram;
- 25 M.6 Chloride channel activators from the class of avermectins and milbemycins, for example abamectin, emamectin benzoate, ivermectin, lepimectin or milbemectin;
- M.7 Juvenile hormone mimics, such as  
M.7A juvenile hormone analogues as hydroprene, kinoprene and methoprene; or others as M.7B fenoxycarb or M.7C pyriproxyfen;  
30
- M.8 miscellaneous non-specific (multi-site) inhibitors, for example  
M.8A alkyl halides as methyl bromide and other alkyl halides, or  
M.8B chloropicrin, or M.8C sulfuric fluoride, or M.8D borax, or M.8E tartar emetic;  
35
- M.9 Selective homopteran feeding blockers, for example  
M.9B pymetrozine, or M.9C flonicamid;
- M.10 Mite growth inhibitors, for example  
40 M.10A clofentezine, hexythiazox and diflovidazin, or M.10B etoxazole;
- M.11 Microbial disruptors of insect midgut membranes, for example *Bacillus thuringiensis* or *Bacillus sphaericus* and the insecticidal proteins they produce such as *Bacillus*

*thuringiensis subsp. israelensis*, *bacillus sphaericus*, *bacillus thuringiensis subsp. aizawai*, *bacillus thuringiensis subsp. kurstaki* and *bacillus thuringiensis subsp. tenebrionis*, or the Bt crop proteins: Cry1Ab, Cry1Ac, Cry1Fa, Cry2Ab, mCry3A, Cry3Ab, Cry3Bb and Cry34/35Ab1;

5

M.12 Inhibitors of mitochondrial ATP synthase, for example

M.12A diafenthiuron, or

M.12B organotin miticides such as azocyclotin, cyhexatin or fenbutatin oxide, or M.12C propargite, or M.12D tetradifon;

10

M.13 Uncouplers of oxidative phosphorylation via disruption of the proton gradient, for example chlorfenapyr, DNOC or sulfluramid;

M.14 Nicotinic acetylcholine receptor (nAChR) channel blockers, for example nereis-

15

toxin analogues as bensultap, cartap hydrochloride, thiocyclam or thiosultap sodium;

M.15 Inhibitors of the chitin biosynthesis type 0, such as benzoylureas as for example bistrifluron, chlorfluazuron, diflubenzuron, flucycloxuron, flufenoxuron, hexaflumuron, lufenuron, novaluron, noviflumuron, teflubenzuron or triflumuron;

20

M.16 Inhibitors of the chitin biosynthesis type 1, as for example buprofezin;

M.17 Moulting disruptors, Dipteran, as for example cyromazine;

25

M.18 Ecdyson receptor agonists such as diacylhydrazines, for example methoxyfenozone, tebufenozide, halofenozide, fufenozide or chromafenozide;

M.19 Octopamin receptor agonists, as for example amitraz;

30

M.20 Mitochondrial complex III electron transport inhibitors, for example M.20A hydramethylnon, or M.20B acequinocyl, or M.20C fluacrypyrim;

M.21 Mitochondrial complex I electron transport inhibitors, for example

35

M.21A METI acaricides and insecticides such as fenazaquin, fenpyroximate, pyrimidifen, pyridaben, tebufenpyrad or tolfenpyrad, or M.21B rotenone;

M.22 Voltage-dependent sodium channel blockers, for example

M.22A indoxacarb, or M.22B metaflumizone;

40

M.23 Inhibitors of the of acetyl CoA carboxylase, such as Tetric and Tetramic acid derivatives, for example spirodiclofen, spiromesifen or spirotetramat;

M.24 Mitochondrial complex IV electron transport inhibitors, for example

M.24A phosphine such as aluminium phosphide, calcium phosphide, phosphine or zinc phosphide, or M.24B cyanide.

5 M.25 Mitochondrial complex II electron transport inhibitors, such as beta-ketonitrile derivatives, for example cyenopyrafen or cyflumetofen;

M.28 Ryanodine receptor-modulators from the class of diamides, as for example flubendiamide, chloranthraniliprole (rynaxypyr®), cyanthraniliprole (cyazypyr®), or the phthalamide compounds

10 M.28.1: (R)-3-Chlor-N1-{2-methyl-4-[1,2,2,2 – tetrafluor-1-(trifluormethyl)ethyl]phenyl}-N2-(1-methyl-2-methylsulfonylethyl)phthalamid and

M.28.2: (S)-3-Chlor-N1-{2-methyl-4-[1,2,2,2 – tetrafluor-1-(trifluormethyl)ethyl]phenyl}-N2-(1-methyl-2-methylsulfonylethyl)phthalamid, or the compound

15 M.28.3: 3-bromo-N-{2-bromo-4-chloro-6-[(1-cyclopropylethyl)carbamoyl]phenyl}-1-(3-chloropyridin-2-yl)-1H-pyrazole-5-carboxamide, or the compound

M.28.4: methyl-2-[3,5-dibromo-2-{{[3-bromo-1-(3-chloropyridin-2-yl)-1H-pyrazol-5-yl]carbonyl}amino)benzoyl]-1,2-dimethylhydrazinecarboxylate;

20 M.X insecticidal active compounds of unknown or uncertain mode of action, as for example azadirachtin, amidoflumet, benzoximate, bifenazate, bromopropylate, chinomethionat, cryolite, dicofol, flufenerim, flometoquin, fluensulfone, flupyradifurone, piperonyl butoxide, pyridalyl, pyrifluquinazon, sulfoxaflor, or the compound

M.X.1: 4-[5-(3,5-Dichloro-phenyl)-5-trifluoromethyl-4,5-dihydro-isoxazol-3-yl]-2-methyl-N-[(2,2,2-trifluoro-ethylcarbamoyl)-methyl]-benzamide, or the compound

25 M.X.2: cyclopropaneacetic acid, 1,1'-[[(3S,4R,4aR,6S,6aS,12R,12aS,12bS)-4-[[[(2-cyclopropylacetyl)oxy]methyl]-1,3,4,4a,5,6,6a,12,12a,12b-decahydro-12-hydroxy-4,6a,12b-trimethyl-11-oxo-9-(3-pyridinyl)-2H,11H-naphtho[2,1-b]pyrano[3,4-e]pyran-3,6-diy]] ester, or the compound

30 M.X.3: 11-(4-chloro-2,6-dimethylphenyl)-12-hydroxy-1,4-dioxo-9-azadispiro[4.2.4.2]-tetradec-11-en-10-one, or the compound

M.X.4: 3-(4'-fluoro-2,4-dimethylbiphenyl-3-yl)-4-hydroxy-8-oxa-1-azaspiro[4.5]dec-3-en-2-one, or the compound

M.X.5: 1-[2-fluoro-4-methyl-5-[(2,2,2-trifluoroethyl)sulfinyl]phenyl]-3-(trifluoromethyl)-1H-1,2,4-triazole-5-amine, or actives on basis of *bacillus firmus* (Votivo, I-1582).

35

The commercially available compounds of the group M listed above may be found in The Pesticide Manual, 15th Edition, C. D. S. Tomlin, British Crop Protection Council (2011) among other publications.

40 The phthalamides M.28.1 and M.28.2 are both known from WO 2007/101540. The anthranilamide M.28.3 has been described in WO2005/077943. The hydrazide compound M.28.4 has been described in WO 2007/043677.-The quinoline derivative flometoquin is shown in WO2006/013896. The aminofuranone compounds flupyradifurone is known from WO 2007/115644. The sulfoximine compound sulfoxaflor is known from

WO2007/149134. The isoxazoline compound M.X.1 has been described in WO2005/085216. The pyripyropene derivative M.X.2 has been described in WO2006/129714. The spiroketal-substituted cyclic ketoenol derivative M.X.3 is known from WO2006/089633 and the biphenyl-substituted spirocyclic ketoenol derivative M.X.4  
 5 from WO2008/067911. Finally triazolylphenylsulfide like M.X.5 have been described in WO2006/043635 and biological control agents on basis of *bacillus firmus* in WO2009/124707.

The following list of active fungicidal substances, in conjunction with which the compounds according to the invention can be used, is intended to illustrate the possible combinations but does not limit them:  
 10

#### F.I) Respiration Inhibitors

##### F.I-1) Inhibitors of complex III at Qo site (e.g. strobilurins)

15 strobilurins: azoxystrobin, dimoxystrobin, enestroburin, fluoxastrobin, kresoxim-methyl, metominostrobin, orysastrobin, picoxystrobin, pyraclostrobin, pyrametostrobin, pyraoxystrobin, pyribencarb, trifloxystrobin, methyl (2-chloro-5 [1-(3-methylbenzyloxyimino)ethyl]benzyl)carbamate and 2 (2-(3-(2,6-dichlorophenyl)-1-methyl-allylideneaminooxymethyl)-phenyl)-2-methoxyimino-N methyl-acetamide;  
 20 oxazolinediones and imidazolinones: famoxadone, fenamidone;

##### F.I-2) Inhibitors of complex II (e.g. carboxamides):

carboxanilides: benodanil, bixafen, boscalid, carboxin, fenfuram, fenhexamid, flupyram, flutolanil, furametpyr, isopyrazam, isotianil, mepronil, oxycarboxin, penflufen, penthiopyrad, sedaxane, tecloftalam, thifluzamide, tiadinil, 2-amino-4 methyl-thiazole-5-  
 25 carboxanilide, N-(3',4',5' trifluorobiphenyl-2 yl)-3-difluoromethyl-1-methyl-1H-pyrazole-4 carboxamide, N-(4'-trifluoromethylthiobiphenyl-2-yl)-3 difluoromethyl-1-methyl-1H pyrazole-4-carboxamide and N-(2-(1,3,3-trimethyl-butyl)-phenyl)-1,3-dimethyl-5 fluoro-1H-pyrazole-4 carboxamide;

##### F.I-3) Inhibitors of complex III at Qi site: cyazofamid, amisulbrom;

##### F.I-4) Other respiration inhibitors (complex I, uncouplers)

diflumerimor; tecnazen; ferimzone; ametoctradin; silthiofam;  
 nitrophenyl derivates: binapacryl, dinobuton, dinocap, fluazinam, nitrthal-isopropyl,  
 organometal compounds: fentin salts, such as fentin-acetate, fentin chloride or fentin hydroxide;

#### 35 F.II) Sterol biosynthesis inhibitors (SBI fungicides)

##### F.II-1) C14 demethylase inhibitors (DMI fungicides, e.g. triazoles, imidazoles)

triazoles: azaconazole, bitertanol, bromuconazole, cyproconazole, difenoconazole, diniconazole, diniconazole-M, epoxiconazole, fenbuconazole, fluquinconazole, flusilazole, flutriafol, hexaconazole, imibenconazole, ipconazole, metconazole, myclobutanil,  
 40 paclobutrazole, penconazole, propiconazole, prothioconazole, simeconazole, tebuconazole, tetraconazole, triadimefon, triadimenol, triticonazole, uniconazole;  
 imidazoles: imazalil, pefurazoate, oxpoconazole, prochloraz, triflumizole;  
 pyrimidines, pyridines and piperazines: fenarimol, nuarimol, pyrifenoxy, triforine;

- F.II-2) Delta14-reductase inhibitors (Amines, e.g. morpholines, piperidines)  
morpholines: aldimorph, dodemorph, dodemorph-acetate, fenpropimorph, tridemorph;  
piperidines: fenpropidin, piperalin;  
spiroketalamines: spiroxamine;
- 5 F.II-3) Inhibitors of 3-keto reductase: hydroxyanilides: fenhexamid;
- F.III) Nucleic acid synthesis inhibitors  
F.III-1) RNA, DNA synthesis  
phenylamides or acyl amino acid fungicides: benalaxyl, benalaxyl-M, kiralaxyl, met-  
10 alaxyl, metalaxyl-M (mefenoxam), ofurace, oxadixyl;  
isoxazoles and isothiazolones: hymexazole, octhilinone;  
F.III-2) DNA topoisomerase inhibitors: oxolinic acid;  
F.III-3) Nucleotide metabolism (e.g. adenosin-deaminase)  
hydroxy (2-amino)-pyrimidines: bupirimate;
- 15 F.IV) Inhibitors of cell division and or cytoskeleton  
F.IV-1) Tubulin inhibitors: benzimidazoles and thiophanates: benomyl, carbendazim,  
fuberidazole, thiabendazole, thiophanate-methyl;  
triazolopyrimidines: 5-chloro-7 (4-methylpiperidin-1-yl)-6-(2,4,6-trifluorophenyl)-  
20 [1,2,4]triazolo[1,5 a]pyrimidine  
F.IV-2) Other cell division inhibitors  
benzamides and phenyl acetamides: diethofencarb, ethaboxam, pencycuron, fluopi-  
colide, zoxamide;  
F.IV-3) Actin inhibitors: benzophenones: metrafenone;
- 25 F.V) Inhibitors of amino acid and protein synthesis  
F.V-1) Methionine synthesis inhibitors (anilino-pyrimidines)  
anilino-pyrimidines: cyprodinil, mepanipyrim, nitrapyrin, pyrimethanil;  
F.V-2) Protein synthesis inhibitors (anilino-pyrimidines)  
30 antibiotics: blastidicin-S, kasugamycin, kasugamycin hydrochloride-hydrate, mildiomy-  
cin, streptomycin, oxytetracyclin, polyoxine, validamycin A;
- F.VI) Signal transduction inhibitors  
F.VI-1) MAP / Histidine kinase inhibitors (e.g. anilino-pyrimidines)  
35 dicarboximides: fluoroimid, iprodione, procymidone, vinclozolin;  
phenylpyrroles: fencpiclonil, fludioxonil;  
F.VI-2) G protein inhibitors: quinolines: quinoxyfen;
- F.VII) Lipid and membrane synthesis inhibitors  
40 F.VII-1) Phospholipid biosynthesis inhibitors  
organophosphorus compounds: edifenphos, iprobenfos, pyrazophos;  
dithiolanes: isoprothiolane;  
F.VII-2) Lipid peroxidation

- aromatic hydrocarbons: dicloran, quintozone, tecnazene, tolclofos-methyl, biphenyl, chloroneb, etridiazole;
- F.VII-3) Carboxyl acid amides (CAA fungicides)  
 cinnamic or mandelic acid amides: dimethomorph, flumorph, mandiproamid, pyrimorph;
- 5 valinamide carbamates: benthialvalicarb, iprovalicarb, pyribencarb, valifenalate and N-(1-(1-(4-cyano-phenyl)ethanesulfonyl)-but-2-yl) carbamic acid-(4-fluorophenyl) ester;
- F.VII-4) Compounds affecting cell membrane permeability and fatty acids  
 carbamates: propamocarb, propamocarb-hydrochlorid
- 10 F.VIII) Inhibitors with Multi Site Action  
 F.VIII-1) Inorganic active substances: Bordeaux mixture, copper acetate, copper hydroxide, copper oxychloride, basic copper sulfate, sulfur;
- F.VIII-2) Thio- and dithiocarbamates: ferbam, mancozeb, maneb, metam, methasulfocarb, metiram, propineb, thiram, zineb, ziram;
- 15 F.VIII-3) Organochlorine compounds (e.g. phthalimides, sulfamides, chloronitriles): anilazine, chlorothalonil, captafol, captan, folpet, dichlofluanid, dichlorophen, flusulfamide, hexachlorobenzene, pentachlorophenole and its salts, phthalide, tolylfluanid, N-(4-chloro-2-nitro-phenyl)-N-ethyl-4-methyl-benzenesulfonamide;
- F.VIII-4) Guanidines: guanidine, dodine, dodine free base, guazatine, guazatine-acetate, iminoctadine, iminoctadine-triacetate, iminoctadine-tris(albesilate);
- 20 F.VIII-5) Anthraquinones: dithianon;
- F.IX) Cell wall synthesis inhibitors  
 F.IX-1) Inhibitors of glucan synthesis: validamycin, polyoxin B;
- 25 F.IX-2) Melanin synthesis inhibitors: pyroquilon, tricyclazole, carpropamide, dicyclomet, fenoxanil;
- F.X) Plant defence inducers  
 F.X-1) Salicylic acid pathway: acibenzolar-S-methyl;
- 30 F.X-2) Others: probenazole, isotianil, tiadinil, prohexadione-calcium;  
 phosphonates: fosetyl, fosetyl-aluminum, phosphorous acid and its salts;
- F.XI) Unknown mode of action:  
 bronopol, chinomethionat, cyflufenamid, cymoxanil, dazomet, debacarb, diclomezine,
- 35 difenzoquat, difenzoquat-methylsulfate, diphenylamin, flumetover, flusulfamide, flutianil, methasulfocarb, oxin-copper, proquinazid, tebufloquin, tecloftalam, triazoxide, 2-butoxy-6-iodo-3-propylchromen-4-one, N-(cyclopropylmethoxyimino-(6-difluoromethoxy-2,3-difluoro-phenyl)-methyl)-2-phenyl acetamide, N'-(4-(4-chloro-3-trifluoromethyl-phenoxy)-2,5-dimethyl-phenyl)-N-ethyl-N methyl formamidine, N' (4-(4-
- 40 fluoro-3-trifluoromethyl-phenoxy)-2,5-dimethyl-phenyl)-N-ethyl-N-methyl formamidine, N'-(2-methyl-5-trifluoromethyl-4-(3-trimethylsilanyl-propoxy)-phenyl)-N-ethyl-N-methyl formamidine, N'-(5-difluoromethyl-2 methyl-4-(3-trimethylsilanyl-propoxy)-phenyl)-N-ethyl-N-methyl formamidine, 2-{1-[2-(5-methyl-3-trifluoromethyl-pyrazole-1-yl)-acetyl]-

piperidin-4-yl}-thiazole-4-carboxylic acid methyl-(1,2,3,4-tetrahydro-naphthalen-1-yl)-amide, 2-{1-[2-(5-methyl-3-trifluoromethyl-pyrazole-1-yl)-acetyl]-piperidin-4-yl}-thiazole-4-carboxylic acid methyl-(R)-1,2,3,4-tetrahydro-naphthalen-1-yl-amide, methoxy-acetic acid 6-tert-butyl-8-fluoro-2,3-dimethyl-quinolin-4-yl ester and N-Methyl-2-{1-[5-methyl-3-trifluoromethyl-1H-pyrazol-1-yl)-acetyl]-piperidin-4-yl}-N-[(1R)-1,2,3,4-tetrahydronaphthalen-1-yl]-4-thiazolecarboxamide, 3-[5-(4-chloro-phenyl)-2,3-dimethyl-isoxazolidin-3-yl]-pyridine, 3-[5-(4-methyl-phenyl)-2,3-dimethyl-isoxazolidin-3-yl]-pyridine, 5-amino-2-isopropyl-3-oxo-4-ortho-tolyl-2,3-dihydro-pyrazole-1 carbothioic acid S-allyl ester, N-(6-methoxy-pyridin-3-yl) cyclopropanecarboxylic acid amide, 5-chloro-1 (4,6-dimethoxy-pyrimidin-2-yl)-2-methyl-1H-benzoimidazole, 2-(4-chloro-phenyl)-N-[4-(3,4-dimethoxy-phenyl)-isoxazol-5-yl]-2-prop-2-ynyloxy-acetamide;

#### F.XI) Growth regulators:

abscisic acid, amidochlor, ancymidol, 6-benzylaminopurine, brassinolide, butralin, chlormequat (chlormequat chloride), choline chloride, cyclanilide, daminozide, dikegualac, dimethipin, 2,6-dimethylpuridine, ethephon, flumetralin, flurprimidol, fluthiacet, forchlorfenuron, gibberellic acid, inabenfide, indole-3-acetic acid, maleic hydrazide, mefluidide, mepiquat (mepiquat chloride), naphthaleneacetic acid, N 6 benzyladenine, paclobutrazol, prohexadione (prohexadione-calcium), prohydrojasmon, thidiazuron, triapenthenol, tributyl phosphorotrithioate, 2,3,5 tri iodobenzoic acid, trinexapac-ethyl and uniconazole;

#### F.XII) Biological control agents

antifungal biocontrol agents: *Bacillus subtilis* strain with NRRL No. B-21661 (e.g. RHAPSODY®, SERENADE® MAX and SERENADE® ASO from AgraQuest, Inc., USA.), *Bacillus pumilus* strain with NRRL No. B-30087 (e.g. SONATA® and BALLAD® Plus from AgraQuest, Inc., USA), *Ulocladium oudemansii* (e.g. the product BOTRYZEN from BotriZen Ltd., New Zealand), Chitosan (e.g. ARMOUR-ZEN from BotriZen Ltd., New Zealand).

30

#### Applications

The animal pest, i.e. the insects, arachnids and nematodes, the plant, soil or water in which the plant is growing can be contacted with the present compounds of formula I or composition(s) containing them by any application method known in the art. As such, "contacting" includes both direct contact (applying the compounds/compositions directly on the animal pest or plant - typically to the foliage, stem or roots of the plant) and indirect contact (applying the compounds/compositions to the locus of the animal pest or plant).

40

The compounds of formula I or the pesticidal compositions comprising them may be used to protect growing plants and crops from attack or infestation by animal pests, especially insects, acaridae or arachnids by contacting the plant/crop with a pesticidally

effective amount of compounds of formula I. The term "crop" refers both to growing and harvested crops.

The compounds of the present invention and the compositions comprising them are particularly important in the control of a multitude of insects on various cultivated plants, such as cereal, root crops, oil crops, vegetables, spices, ornamentals, for example seed of durum and other wheat, barley, oats, rye, maize (fodder maize and sugar maize / sweet and field corn), soybeans, oil crops, crucifers, cotton, sunflowers, bananas, rice, oilseed rape, turnip rape, sugarbeet, fodder beet, eggplants, potatoes, grass, lawn, turf, fodder grass, tomatoes, leeks, pumpkin/squash, cabbage, iceberg lettuce, pepper, cucumbers, melons, Brassica species, melons, beans, peas, garlic, onions, carrots, tuberous plants such as potatoes, sugar cane, tobacco, grapes, petunias, geranium/pelargoniums, pansies and impatiens.

The compounds of the present invention are employed as such or in form of compositions by treating the insects or the plants, plant propagation materials, such as seeds, soil, surfaces, materials or rooms to be protected from insecticidal attack with a insecticidally effective amount of the active compounds. The application can be carried out both before and after the infection of the plants, plant propagation materials, such as seeds, soil, surfaces, materials or rooms by the insects.

The present invention also includes a method of combating animal pests which comprises contacting the animal pests, their habit, breeding ground, food supply, cultivated plants, seed, soil, area, material or environment in which the animal pests are growing or may grow, or the materials, plants, seeds, soils, surfaces or spaces to be protected from animal attack or infestation with a pesticidally effective amount of a mixture of at least one active compound I.

Moreover, animal pests may be controlled by contacting the target pest, its food supply, habitat, breeding ground or its locus with a pesticidally effective amount of compounds of formula I. As such, the application may be carried out before or after the infection of the locus, growing crops, or harvested crops by the pest.

The compounds of the invention can also be applied preventively to places at which occurrence of the pests is expected.

The compounds of formula I may be also used to protect growing plants from attack or infestation by pests by contacting the plant with a pesticidally effective amount of compounds of formula I. As such, "contacting" includes both direct contact (applying the compounds/compositions directly on the pest and/or plant - typically to the foliage, stem or roots of the plant) and indirect contact (applying the compounds/compositions to the locus of the pest and/or plant).

"Locus" means a habitat, breeding ground, plant, seed, soil, area, material or environment in which a pest or parasite is growing or may grow.

The term "plant propagation material" is to be understood to denote all the generative parts of the plant such as seeds and vegetative plant material such as cuttings and tubers (e. g. potatoes), which can be used for the multiplication of the plant. This includes seeds, roots, fruits, tubers, bulbs, rhizomes, shoots, sprouts and other parts of plants. Seedlings and young plants, which are to be transplanted after germination or after emergence from soil, may also be included. These plant propagation materials may be treated prophylactically with a plant protection compound either at or before planting or transplanting.

The term "cultivated plants" is to be understood as including plants which have been modified by breeding, mutagenesis or genetic engineering. Genetically modified plants are plants, which genetic material has been so modified by the use of recombinant DNA techniques that under natural circumstances cannot readily be obtained by cross breeding, mutations or natural recombination. Typically, one or more genes have been integrated into the genetic material of a genetically modified plant in order to improve certain properties of the plant. Such genetic modifications also include but are not limited to targeted post-translational modification of protein(s) (oligo- or polypeptides) poly for example by glycosylation or polymer additions such as prenylated, acetylated or farnesylated moieties or PEG moieties (e.g. as disclosed in *Biotechnol Prog.* 2001 Jul-Aug;17(4):720-8., *Protein Eng Des Sel.* 2004 Jan;17(1):57-66, *Nat Protoc.* 2007;2(5):1225-35., *Curr Opin Chem Biol.* 2006 Oct;10(5):487-91. *Epub* 2006 Aug 28., *Biomaterials.* 2001 Mar;22(5):405-17, *Bioconjug Chem.* 2005 Jan-Feb;16(1):113-21).

The term "cultivated plants" is to be understood also including plants that have been rendered tolerant to applications of specific classes of herbicides, such as hydroxy-phenylpyruvate dioxygenase (HPPD) inhibitors; acetolactate synthase (ALS) inhibitors, such as sulfonyl ureas (see e. g. US 6,222,100, WO 01/82685, WO 00/26390, WO 97/41218, WO 98/02526, WO 98/02527, WO 04/106529, WO 05/20673, WO 03/14357, WO 03/13225, WO 03/14356, WO 04/16073) or imidazolinones (see e. g. US 6,222,100, WO 01/82685, WO 00/26390, WO 97/41218, WO 98/02526, WO 98/02527, WO 04/106529, WO 05/20673, WO 03/14357, WO 03/13225, WO 03/14356, WO 04/16073); enolpyruvylshikimate-3-phosphate synthase (EPSPS) inhibitors, such as glyphosate (see e. g. WO 92/00377); glutamine synthetase (GS) inhibitors, such as glufosinate (see e. g. EP-A-0242236, EP-A-242246) or oxynil herbicides (see e. g. US 5,559,024) as a result of conventional methods of breeding or genetic engineering. Several cultivated plants have been rendered tolerant to herbicides by conventional methods of breeding (mutagenesis), for example Clearfield® summer rape (Canola) being tolerant to imidazolinones, e. g. imazamox. Genetic engineering methods have been used to render cultivated plants, such as soybean, cotton, corn, beets and rape, tolerant to herbicides, such as glyphosate and glufosinate, some of which are commer-

cially available under the trade names RoundupReady® (glyphosate) and LibertyLink® (glufosinate).

The term "cultivated plants" is to be understood also including plants that are by the  
5 use of recombinant DNA techniques capable to synthesize one or more insecticidal  
proteins, especially those known from the bacterial genus *Bacillus*, particularly from  
*Bacillus thuringiensis*, such as  $\delta$ -endotoxins, e. g. CryIA(b), CryIA(c), CryIF, CryIF(a2),  
CryIIA(b), CryIIIA, CryIIIB(b1) or Cry9c; vegetative insecticidal proteins (VIP), e. g.  
VIP1, VIP2, VIP3 or VIP3A; insecticidal proteins of bacteria colonizing nematodes, for  
10 example *Photorhabdus* spp. or *Xenorhabdus* spp.; toxins produced by animals, such  
as scorpion toxins, arachnid toxins, wasp toxins, or other insect-specific neurotoxins;  
toxins produced by fungi, such *Streptomyces* toxins, plant lectins, such as pea or  
barley lectins; agglutinins; proteinase inhibitors, such as trypsin inhibitors, serine prote-  
ase inhibitors, patatin, cystatin or papain inhibitors; ribosome-inactivating proteins  
15 (RIP), such as ricin, maize-RIP, abrin, luffin, saporin or bryodin; steroid metabolism  
enzymes, such as 3-hydroxysteroid oxidase, ecdysteroid-IDP-glycosyl-transferase,  
cholesterol oxidases, ecdysone inhibitors or HMG-CoA-reductase; ion channel block-  
ers, such as blockers of sodium or calcium channels; juvenile hormone esterase; diu-  
retic hormone receptors (helicokinin receptors); stilben synthase, bibenzyl synthase,  
20 chitinases or glucanases. In the context of the present invention these insecticidal pro-  
teins or toxins are to be understood expressly also as pre-toxins, hybrid proteins, trun-  
cated or otherwise modified proteins. Hybrid proteins are characterized by a new com-  
bination of protein domains, (see, for example WO 02/015701). Further examples of  
such toxins or genetically-modified plants capable of synthesizing such toxins are  
25 dis-closed, for example, in EP-A 374 753, WO 93/007278, WO 95/34656, EP-A 427  
529, EP-A 451 878, WO 03/018810 und WO 03/052073. The methods for producing  
such genetically modified plants are generally known to the person skilled in the art and  
are described, for example, in the publications mentioned above. These insecticidal  
proteins contained in the genetically modified plants impart to the plants producing the-  
30 se proteins protection from harmful pests from certain taxonomic groups of arthropods,  
particularly to beetles (Coleoptera), flies (Diptera), and butterflies and moths (Lepidop-  
tera) and to plant parasitic nematodes (Nematoda).

The term "cultivated plants" is to be understood also including plants that are by the  
35 use of recombinant DNA techniques capable to synthesize one or more proteins to  
increase the resistance or tolerance of those plants to bacterial, viral or fungal patho-  
gens. Examples of such proteins are the so-called " pathogenesis-related proteins"  
(PR proteins, see, for example EP-A 0 392 225), plant disease resistance genes (for  
example potato cultivars, which express resistance genes acting against *Phytophthora*  
40 *infestans* derived from the mexican wild potato *Solanum bulbocastanum*) or T4-  
lyso-zym (e. g. potato cultivars capable of synthesizing these proteins with increased  
resistance against bacteria such as *Erwinia amylovora*). The methods for producing

such genetically modified plants are generally known to the person skilled in the art and are described, for example, in the publications mentioned above.

5 The term "cultivated plants" is to be understood also including plants that are by the use of recombinant DNA techniques capable to synthesize one or more proteins to increase the productivity (e. g. bio mass production, grain yield, starch content, oil content or protein content), tolerance to drought, salinity or other growth-limiting environmental factors or tolerance to pests and fungal, bacterial or viral pathogens of those plants.

10

The term "cultivated plants" is to be understood also including plants that contain by the use of recombinant DNA techniques a modified amount of substances of content or new substances of content, specifically to improve human or animal nutrition, for example oil crops that produce health-promoting long-chain omega-3 fatty acids or 15 unsaturated omega-9 fatty acids (e. g. Nexera® rape).

The term "cultivated plants" is to be understood also including plants that contain by the use of recombinant DNA techniques a modified amount of substances of content or new substances of content, specifically to improve raw material production, for example 20 potatoes that produce increased amounts of amylopectin (e. g. Amflora® potato).

In general, "pesticidally effective amount" means the amount of active ingredient needed to achieve an observable effect on growth, including the effects of necrosis, death, retardation, prevention, and removal, destruction, or otherwise diminishing the occurrence and activity of the target organism. The pestidally effective amount can vary for 25 the various compounds/compositions used in the invention. A pestidally effective amount of the compositions will also vary according to the prevailing conditions such as desired pestidally effect and duration, weather, target species, locus, mode of application, and the like.

30

In the case of soil treatment or of application to the pests dwelling place or nest, the quantity of active ingredient ranges from 0.0001 to 500 g per 100 m<sup>2</sup>, preferably from 0.001 to 20 g per 100 m<sup>2</sup>.

35 Customary application rates in the protection of materials are, for example, from 0.01 g to 1000 g of active compound per m<sup>2</sup> treated material, desirably from 0.1 g to 50 g per m<sup>2</sup>.

40 Insecticidal compositions for use in the impregnation of materials typically contain from 0.001 to 95 weight %, preferably from 0.1 to 45 weight %, and more preferably from 1 to 25 weight % of at least one repellent and/or insecticide.

For use in treating crop plants, the rate of application of the active ingredients of this invention may be in the range of 0.1 g to 4000 g per hectare, desirably from 25 g to 600 g per hectare, more desirably from 50 g to 500 g per hectare.

- 5 The compounds of formula I are effective through both contact (via soil, glass, wall, bed net, carpet, plant parts or animal parts), and ingestion (bait, or plant part).

- The compounds of the invention may also be applied against non-crop insect pests, such as ants, termites, wasps, flies, mosquitos, crickets, or cockroaches. For use  
10 against said non-crop pests, compounds of formula I are preferably used in a bait composition.

- The bait can be a liquid, a solid or a semisolid preparation (e.g. a gel). Solid baits can be formed into various shapes and forms suitable to the respective application e.g.  
15 granules, blocks, sticks, disks. Liquid baits can be filled into various devices to ensure proper application, e.g. open containers, spray devices, droplet sources, or evaporation sources. Gels can be based on aqueous or oily matrices and can be formulated to particular necessities in terms of stickyness, moisture retention or aging characteristics.

- 20 The bait employed in the composition is a product, which is sufficiently attractive to incite insects such as ants, termites, wasps, flies, mosquitos, crickets etc. or cockroaches to eat it. The attractiveness can be manipulated by using feeding stimulants or sex pheromones. Food stimulants are chosen, for example, but not exclusively, from animal and/or plant proteins (meat-, fish- or blood meal, insect parts, egg yolk), from  
25 fats and oils of animal and/or plant origin, or mono-, oligo- or polyorganosaccharides, especially from sucrose, lactose, fructose, dextrose, glucose, starch, pectin or even molasses or honey. Fresh or decaying parts of fruits, crops, plants, animals, insects or specific parts thereof can also serve as a feeding stimulant. Sex pheromones are known to be more insect specific. Specific pheromones are described in the literature  
30 and are known to those skilled in the art.

- For use in bait compositions, the typical content of active ingredient is from 0.001 weight % to 15 weight %, desirably from 0.001 weight % to 5% weight % of active  
35 compound.

- Formulations of compounds of formula I as aerosols (e.g in spray cans), oil sprays or pump sprays are highly suitable for the non-professional user for controlling pests such as flies, fleas, ticks, mosquitos or cockroaches. Aerosol recipes are preferably composed of the active compound, solvents such as lower alcohols (e.g. methanol, etha-  
40 nol, propanol, butanol), ketones (e.g. acetone, methyl ethyl ketone), paraffin hydrocarbons (e.g. kerosenes) having boiling ranges of approximately 50 to 250 °C, dimethylformamide, N-methylpyrrolidone, dimethyl sulfoxide, aromatic hydrocarbons such as toluene, xylene, water, furthermore auxiliaries such as emulsifiers such as sorbitol

monooleate, oleyl ethoxylate having 3-7 mol of ethylene oxide, fatty alcohol ethoxylate, perfume oils such as ethereal oils, esters of medium fatty acids with lower alcohols, aromatic carbonyl compounds, if appropriate stabilizers such as sodium benzoate, amphoteric surfactants, lower epoxides, triethyl orthoformate and, if required, propellants  
5 such as propane, butane, nitrogen, compressed air, dimethyl ether, carbon dioxide, nitrous oxide, or mixtures of these gases.

The oil spray formulations differ from the aerosol recipes in that no propellants are used.

10

For use in spray compositions, the content of active ingredient is from 0.001 to 80 weights %, preferably from 0.01 to 50 weight % and most preferably from 0.01 to 15 weight %.

15 The compounds of formula I and its respective compositions can also be used in mosquito and fumigating coils, smoke cartridges, vaporizer plates or long-term vaporizers and also in moth papers, moth pads or other heat-independent vaporizer systems.

20 Methods to control infectious diseases transmitted by insects (e.g. malaria, dengue and yellow fever, lymphatic filariasis, and leishmaniasis) with compounds of formula I and its respective compositions also comprise treating surfaces of huts and houses, air spraying and impregnation of curtains, tents, clothing items, bed nets, tsetse-fly trap or the like. Insecticidal compositions for application to fibers, fabric, knitgoods, nonwovens, netting material or foils and tarpaulins preferably comprise a mixture including the  
25 insecticide, optionally a repellent and at least one binder. Suitable repellents for example are N,N-Diethyl-meta-toluamide (DEET), N,N-diethylphenylacetamide (DEPA), 1-(3-cyclohexan-1-yl-carbonyl)-2-methylpiperine, (2-hydroxymethylcyclohexyl) acetic acid lactone, 2-ethyl-1,3-hexandiol, indalone, Methylneodecanamide (MNDA), a pyrethroid not used for insect control such as {(+/-)-3-allyl-2-methyl-4-oxocyclopent-2-(+)-enyl-(+)-  
30 trans-chrysantemate (Esbiothrin), a repellent derived from or identical with plant extracts like limonene, eugenol, (+)-Eucamalol (1), (-)-1-epi-eucamalol or crude plant extracts from plants like Eucalyptus maculata, Vitex rotundifolia, Cymbopogon martinii, Cymbopogon citratus (lemon grass), Cymopogon nartdus (citronella). Suitable binders are selected for example from polymers and copolymers of vinyl esters of aliphatic acids (such as such as vinyl acetate and vinyl versatate), acrylic and methacrylic esters of  
35 alcohols, such as butyl acrylate, 2-ethylhexylacrylate, and methyl acrylate, mono- and di-ethylenically unsaturated hydrocarbons, such as styrene, and aliphatic diens, such as butadiene.

40 The impregnation of curtains and bednets is done in general by dipping the textile material into emulsions or dispersions of the insecticide or spraying them onto the nets.

The compounds of formula I and its compositions can be used for protecting wooden materials such as trees, board fences, sleepers, etc. and buildings such as houses, outhouses, factories, but also construction materials, furniture, leathers, fibers, vinyl articles, electric wires and cables etc. from ants and/or termites, and for controlling ants and termites from doing harm to crops or human being (e.g. when the pests invade into houses and public facilities). The compounds of formula I are applied not only to the surrounding soil surface or into the under-floor soil in order to protect wooden materials but it can also be applied to lumbered articles such as surfaces of the under-floor concrete, alcove posts, beams, plywoods, furniture, etc., wooden articles such as particle boards, half boards, etc. and vinyl articles such as coated electric wires, vinyl sheets, heat insulating material such as styrene foams, etc. In case of application against ants doing harm to crops or human beings, the ant controller of the present invention is applied to the crops or the surrounding soil, or is directly applied to the nest of ants or the like.

15

#### Seed treatment

The compounds of formula I are also suitable for the treatment of seeds in order to protect the seed from insect pest, in particular from soil-living insect pests and the resulting plant's roots and shoots against soil pests and foliar insects.

20

The compounds of formula I are particularly useful for the protection of the seed from soil pests and the resulting plant's roots and shoots against soil pests and foliar insects. The protection of the resulting plant's roots and shoots is preferred. More preferred is the protection of resulting plant's shoots from piercing and sucking insects, wherein the protection from aphids is most preferred.

25

The present invention therefore comprises a method for the protection of seeds from insects, in particular from soil insects and of the seedling's roots and shoots from insects, in particular from soil and foliar insects, said method comprising contacting the seeds before sowing and/or after pregermination with a compound of the general formula I or a salt thereof. Particularly preferred is a method, wherein the plant's roots and shoots are protected, more preferably a method, wherein the plants shoots are protected from piercing and sucking insects, most preferably a method, wherein the plants shoots are protected from aphids.

30

35

The term seed embraces seeds and plant propagules of all kinds including but not limited to true seeds, seed pieces, suckers, corms, bulbs, fruit, tubers, grains, cuttings, cut shoots and the like and means in a preferred embodiment true seeds.

40

The term seed treatment comprises all suitable seed treatment techniques known in the art, such as seed dressing, seed coating, seed dusting, seed soaking and seed pelleting.

5 The present invention also comprises seeds coated with or containing the active compound.

10 The term "coated with and/or containing" generally signifies that the active ingredient is for the most part on the surface of the propagation product at the time of application, although a greater or lesser part of the ingredient may penetrate into the propagation product, depending on the method of application. When the said propagation product is (re)planted, it may absorb the active ingredient.

15 Suitable seed is seed of cereals, root crops, oil crops, vegetables, spices, ornamentals, for example seed of durum and other wheat, barley, oats, rye, maize (fodder maize and sugar maize / sweet and field corn), soybeans, oil crops, crucifers, cotton, sunflowers, bananas, rice, oilseed rape, turnip rape, sugarbeet, fodder beet, eggplants, potatoes, grass, lawn, turf, fodder grass, tomatoes, leeks, pumpkin/squash, cabbage, iceberg lettuce, pepper, cucumbers, melons, Brassica species, melons, beans, peas, garlic, onions, carrots, tuberous plants such as potatoes, sugar cane, tobacco, grapes, petunias, geranium/pelargoniums, pansies and impatiens.

20 In addition, the active compound may also be used for the treatment seeds from plants, which tolerate the action of herbicides or fungicides or insecticides owing to breeding, including genetic engineering methods.

25 For example, the active compound can be employed in treatment of seeds from plants, which are resistant to herbicides from the group consisting of the sulfonylureas, imidazolinones, glufosinate-ammonium or glyphosate-isopropylammonium and analogous active substances (see for example, EP-A-0242236, EP-A-242246) (WO 92/00377) (EP-A-0257993, U.S. Pat. No. 5,013,659) or in transgenic crop plants, for example cotton, with the capability of producing *Bacillus thuringiensis* toxins (Bt toxins) which make the plants resistant to certain pests (EP-A-0142924, EP-A-0193259),

35 Furthermore, the active compound can be used also for the treatment of seeds from plants, which have modified characteristics in comparison with existing plants consist, which can be generated for example by traditional breeding methods and/or the generation of mutants, or by recombinant procedures). For example, a number of cases have been described of recombinant modifications of crop plants for the purpose of modifying the starch synthesized in the plants (e.g. WO 92/11376, WO 92/14827, WO 40 91/19806) or of transgenic crop plants having a modified fatty acid composition (WO 91/13972).

The seed treatment application of the active compound is carried out by spraying or by dusting the seeds before sowing of the plants and before emergence of the plants.

Compositions which are especially useful for seed treatment are e.g.:

- 5
- A Soluble concentrates (SL, LS)
  - D Emulsions (EW, EO, ES)
  - E Suspensions (SC, OD, FS)
  - F Water-dispersible granules and water-soluble granules (WG, SG)
  - 10 G Water-dispersible powders and water-soluble powders (WP, SP, WS)
  - H Gel-Formulations (GF)
  - I Dustable powders (DP, DS)

15 Conventional seed treatment formulations include for example flowable concentrates FS, solutions LS, powders for dry treatment DS, water dispersible powders for slurry treatment WS, water-soluble powders SS and emulsion ES and EC and gel formulation GF. These formulations can be applied to the seed diluted or undiluted. Application to the seeds is carried out before sowing, either directly on the seeds or after having pre-germinated the latter

20

In a preferred embodiment a FS formulation is used for seed treatment. Typically, a FS formulation may comprise 1-800 g/l of active ingredient, 1-200 g/l Surfactant, 0 to 200 g/l antifreezing agent, 0 to 400 g/l of binder, 0 to 200 g/l of a pigment and up to 1 liter of a solvent, preferably water.

25

Especially preferred FS formulations of compounds of formula I for seed treatment usually comprise from 0.1 to 80% by weight (1 to 800 g/l) of the active ingredient, from 0.1 to 20 % by weight (1 to 200 g/l) of at least one surfactant, e.g. 0.05 to 5 % by weight of a wetter and from 0.5 to 15 % by weight of a dispersing agent, up to 20 % by weight, e.g. from 5 to 20 % of an anti-freeze agent, from 0 to 15 % by weight, e.g. 1 to 15 % by weight of a pigment and/or a dye, from 0 to 40 % by weight, e.g. 1 to 40 % by weight of a binder (sticker /adhesion agent), optionally up to 5 % by weight, e.g. from 0.1 to 5 % by weight of a thickener, optionally from 0.1 to 2 % of an anti-foam agent, and optionally a preservative such as a biocide, antioxidant or the like, e.g. in an amount from 0.01 to 1 % by weight and a filler/vehicle up to 100 % by weight.

30

35

Seed Treatment formulations may additionally also comprise binders and optionally colorants.

40

Binders can be added to improve the adhesion of the active materials on the seeds after treatment. Suitable binders are homo- and copolymers from alkylene oxides like ethylene oxide or propylene oxide, polyvinylacetate, polyvinylalcohols, polyvinylpyrrolidones, and copolymers thereof, ethylene-vinyl acetate copolymers, acrylic homo- and

copolymers, polyethyleneamines, polyethyleneamides and polyethyleneimines, polysaccharides like celluloses, tylose and starch, polyolefin homo- and copolymers like olefin/maleic anhydride copolymers, polyurethanes, polyesters, polystyrene homo and copolymers

5

Optionally, also colorants can be included in the formulation. Suitable colorants or dyes for seed treatment formulations are Rhodamin B, C.I. Pigment Red 112, C.I. Solvent Red 1, pigment blue 15:4, pigment blue 15:3, pigment blue 15:2, pigment blue 15:1, pigment blue 80, pigment yellow 1, pigment yellow 13, pigment red 112, pigment red 48:2, pigment red 48:1, pigment red 57:1, pigment red 53:1, pigment orange 43, pigment orange 34, pigment orange 5, pigment green 36, pigment green 7, pigment white 6, pigment brown 25, basic violet 10, basic violet 49, acid red 51, acid red 52, acid red 14, acid blue 9, acid yellow 23, basic red 10, basic red 108.

15 Examples of a gelling agent is carrageen (Satiage<sup>®</sup>)

In the treatment of seed, the application rates of the compounds I are generally from 0.1 g to 10 kg per 100 kg of seed, preferably from 1 g to 5 kg per 100 kg of seed, more preferably from 1 g to 1000 g per 100 kg of seed and in particular from 1 g to 200 g per 20 100 kg of seed.

The invention therefore also relates to seed comprising a compound of the formula I, or an agriculturally useful salt of I, as defined herein. The amount of the compound I or the agriculturally useful salt thereof will in general vary from 0.1 g to 10 kg per 100 kg 25 of seed, preferably from 1 g to 5 kg per 100 kg of seed, in particular from 1 g to 1000 g per 100 kg of seed. For specific crops such as lettuce the rate can be higher.

Animal health

30

The compounds of formula I or the enantiomers or veterinarily acceptable salts thereof are in particular also suitable for being used for combating parasites in and on animals.

An object of the present invention is therefore also to provide new methods to control 35 parasites in and on animals. Another object of the invention is to provide safer pesticides for animals. Another object of the invention is further to provide pesticides for animals that may be used in lower doses than existing pesticides. And another object of the invention is to provide pesticides for animals, which provide a long residual control of the parasites.

40

The invention also relates to compositions containing a parasitically effective amount of compounds of formula I or the enantiomers or veterinarily acceptable salts thereof and an acceptable carrier, for combating parasites in and on animals.

The present invention also provides a method for treating, controlling, preventing and protecting animals against infestation and infection by parasites, which comprises orally, topically or parenterally administering or applying to the animals a parasitically effective amount of a compound of formula I or the enantiomers or veterinarily acceptable salts thereof or a composition comprising it.

The invention also provides a process for the preparation of a composition for treating, controlling, preventing or protecting animals against infestation or infection by parasites which comprises a parasitically effective amount of a compound of formula I or the enantiomers or veterinarily acceptable salts thereof or a composition comprising it.

Activity of compounds against agricultural pests does not suggest their suitability for control of endo- and ectoparasites in and on animals which requires, for example, low, non-emetic dosages in the case of oral application, metabolic compatibility with the animal, low toxicity, and a safe handling.

Surprisingly it has now been found that compounds of formula I are suitable for combating endo- and ectoparasites in and on animals.

Compounds of formula I or the enantiomers or veterinarily acceptable salts thereof and compositions comprising them are preferably used for controlling and preventing infestations and infections animals including warm-blooded animals (including humans) and fish. They are for example suitable for controlling and preventing infestations and infections in mammals such as cattle, sheep, swine, camels, deer, horses, pigs, poultry, rabbits, goats, dogs and cats, water buffalo, donkeys, fallow deer and reindeer, and also in fur-bearing animals such as mink, chinchilla and raccoon, birds such as hens, geese, turkeys and ducks and fish such as fresh- and salt-water fish such as trout, carp and eels.

Compounds of formula I or the enantiomers or veterinarily acceptable salts thereof and compositions comprising them are preferably used for controlling and preventing infestations and infections in domestic animals, such as dogs or cats.

Infestations in warm-blooded animals and fish include, but are not limited to, lice, biting lice, ticks, nasal bots, keds, biting flies, muscoid flies, flies, myiasitic fly larvae, chiggers, gnats, mosquitoes and fleas.

The compounds of formula I or the enantiomers or veterinarily acceptable salts thereof and compositions comprising them are suitable for systemic and/or non-systemic control of ecto- and/or endoparasites. They are active against all or some stages of development.

The compounds of formula I are especially useful for combating ectoparasites.

The compounds of formula I are especially useful for combating parasites of the following orders and species, respectively:

5

fleas (Siphonaptera), e.g. *Ctenocephalides felis*, *Ctenocephalides canis*, *Xenopsylla cheopis*, *Pulex irritans*, *Tunga penetrans*, and *Nosopsyllus fasciatus*,

10

cockroaches (Blattaria - Blattodea), e.g. *Blattella germanica*, *Blattella asahinae*, *Periplaneta americana*, *Periplaneta japonica*, *Periplaneta brunnea*, *Periplaneta fuliginosa*, *Periplaneta australasiae*, and *Blatta orientalis*,

15

flies, mosquitoes (Diptera), e.g. *Aedes aegypti*, *Aedes albopictus*, *Aedes vexans*, *Anastrepha ludens*, *Anopheles maculipennis*, *Anopheles crucians*, *Anopheles albimanus*, *Anopheles gambiae*, *Anopheles freeborni*, *Anopheles leucosphyrus*, *Anopheles minimus*, *Anopheles quadrimaculatus*, *Calliphora vicina*, *Chrysomya bezziana*, *Chrysomya hominivorax*, *Chrysomya macellaria*, *Chrysops discalis*, *Chrysops silacea*, *Chrysops atlanticus*, *Cochliomyia hominivorax*, *Cordylobia anthropophaga*, *Culicoides furens*, *Culex pipiens*, *Culex nigripalpus*, *Culex quinquefasciatus*, *Culex tarsalis*, *Culiseta inornata*, *Culiseta melanura*, *Dermatobia hominis*, *Fannia canicularis*, *Gasterophilus intestinalis*, *Glossina morsitans*, *Glossina palpalis*, *Glossina fuscipes*, *Glossina tachinoides*, *Haematobia irritans*, *Haplodiplosis equestris*, *Hippelates spp.*, *Hypoderma lineata*, *Lep-  
toconops torrens*, *Lucilia caprina*, *Lucilia cuprina*, *Lucilia sericata*, *Lycoria pectoralis*, *Manson-  
sonia spp.*, *Musca domestica*, *Muscina stabulans*, *Oestrus ovis*, *Phlebotomus ar-  
gentipes*, *Psorophora columbiae*, *Psorophora discolor*, *Prosimulium mixtum*, *Sar-  
cophaga haemorrhoidalis*, *Sarcophaga sp.*, *Simulium vittatum*, *Stomoxys calcitrans*, *Tabanus bovinus*, *Tabanus atratus*, *Tabanus lineola*, and *Tabanus similis*,

20

25

30

lice (Phthiraptera), e.g. *Pediculus humanus capitis*, *Pediculus humanus corporis*, *Pthirus pubis*, *Haematopinus eurysternus*, *Haematopinus suis*, *Linognathus vituli*, *Bovicola bovis*, *Menopon gallinae*, *Menacanthus stramineus* and *Solenopotes capillatus*.

35

ticks and parasitic mites (Parasitiformes): ticks (Ixodida), e.g. *Ixodes scapularis*, *Ixodes holocyclus*, *Ixodes pacificus*, *Rhiphicephalus sanguineus*, *Dermacentor andersoni*, *Dermacentor variabilis*, *Amblyomma americanum*, *Ambryomma maculatum*, *Ornithodoros hermsi*, *Ornithodoros turicata* and parasitic mites (Mesostigmata), e.g. *Ornithonyssus bacoti* and *Dermanyssus gallinae*,

40

Actinedida (Prostigmata) und Acaridida (Astigmata) e.g. *Acarapis spp.*, *Cheyletiella spp.*, *Ornithocheyletia spp.*, *Myobia spp.*, *Psorergates spp.*, *Demodex spp.*, *Trombicula spp.*, *Listrophorus spp.*, *Acarus spp.*, *Tyrophagus spp.*, *Caloglyphus spp.*, *Hypodectes spp.*, *Pterolichus spp.*, *Psoroptes spp.*, *Chorioptes spp.*, *Otodectes spp.*, *Sarcoptes spp.*, *Notoedres spp.*, *Knemidocoptes spp.*, *Cytodites spp.*, and *Laminosioptes spp.*

Bugs (Heteroptera): *Cimex lectularius*, *Cimex hemipterus*, *Reduvius senilis*, *Triatoma spp.*, *Rhodnius spp.*, *Panstrongylus spp.* and *Arius critatus*,

- 5 Anoplurida, e.g. *Haematopinus spp.*, *Linognathus spp.*, *Pediculus spp.*, *Phthirus spp.*, and *Solenopotes spp.*,

- Mallophagida (suborders Amblycerina and Ischnocerina), e.g. *Trimenopon spp.*, *Menopon spp.*, *Trinoton spp.*, *Bovicola spp.*, *Werneckiella spp.*, *Lepikentron spp.*, *Trichodectes spp.*, and *Felicola spp.*,  
10

Roundworms Nematoda:

- Wipeworms and Trichinosis (Trichosyringida), e.g. Trichinellidae (*Trichinella spp.*), (Trichuridae) *Trichuris spp.*, *Capillaria spp.*,  
15

Rhabditida, e.g. *Rhabditis spp.*, *Strongyloides spp.*, *Helicephalobus spp.*,

- Strongylida, e.g. *Strongylus spp.*, *Ancylostoma spp.*, *Necator americanus*, *Bunostomum spp.* (Hookworm), *Trichostrongylus spp.*, *Haemonchus contortus.*, *Ostertagia spp.*,  
20 , *Cooperia spp.*, *Nematodirus spp.*, *Dictyocaulus spp.*, *Cyathostoma spp.*, *Oesophagostomum spp.*, *Stephanurus dentatus*, *Ollulanus spp.*, *Chabertia spp.*, *Stephanurus dentatus* , *Syngamus trachea*, *Ancylostoma spp.*, *Uncinaria spp.*, *Globocephalus spp.*, *Necator spp.*, *Metastrongylus spp.*, *Muellerius capillaris*, *Protostrongylus spp.*,  
25 *Angiostrongylus spp.*, *Parelaphostrongylus spp.* *Aleurostrongylus abstrusus*, and *Dioctophyma renale*,

- Intestinal roundworms (Ascaridida), e.g. *Ascaris lumbricoides*, *Ascaris suum*, *Ascaridia galli*, *Parascaris equorum*, *Enterobius vermicularis* (Threadworm), *Toxocara canis*,  
30 *Toxascaris leonine*, *Skrjabinema spp.*, and *Oxyuris equi*,

Camallanida, e.g. *Dracunculus medinensis* (guinea worm)

- Spirurida, e.g. *Thelazia spp.* *Wuchereria spp.*, *Brugia spp.*, *Onchocerca spp.*, *Dirofilari spp.a*, *Dipetalonema spp.*, *Setaria spp.*, *Elaeophora spp.*, *Spirocerca lupi*, and *Habronema spp.*,  
35

- Thorny headed worms (Acanthocephala), e.g. *Acanthocephalus spp.*, *Macracanthorhynchus hirudinaceus* and *Oncicola spp.*,  
40

Planarians (Plathelminthes):

Flukes (Trematoda), e.g. *Faciola spp.*, *Fascioloides magna*, *Paragonimus spp.*, *Dicrocoelium spp.*, *Fasciolopsis buski*, *Clonorchis sinensis*, *Schistosoma spp.*, *Trichobilharzia spp.*, *Alaria alata*, *Paragonimus spp.*, and *Nanocyetes spp.*

- 5 Cercomeromorpha, in particular Cestoda (Tapeworms), e.g. *Diphylobothrium spp.*, *Tenia spp.*, *Echinococcus spp.*, *Dipylidium caninum*, *Multiceps spp.*, *Hymenolepis spp.*, *Mesocestoides spp.*, *Vampirolepis spp.*, *Moniezia spp.*, *Anoplocephala spp.*, *Sirometra spp.*, *Anoplocephala spp.*, and *Hymenolepis spp.*

- 10 The compounds of formula I and compositions containing them are particularly useful for the control of pests from the orders Diptera, Siphonaptera and Ixodida.

Moreover, the use of the compounds of formula I and compositions containing them for combating mosquitoes is especially preferred.

- 15 The use of the compounds of formula I and compositions containing them for combating flies is a further preferred embodiment of the present invention.

- 20 Furthermore, the use of the compounds of formula I and compositions containing them for combating fleas is especially preferred.

The use of the compounds of formula I and compositions containing them for combating ticks is a further preferred embodiment of the present invention.

- 25 The compounds of formula I also are especially useful for combating endoparasites (roundworms nematoda, thorny headed worms and planarians).

Administration can be carried out both prophylactically and therapeutically.

- 30 Administration of the active compounds is carried out directly or in the form of suitable preparations, orally, topically/dermally or parenterally.

- 35 For oral administration to warm-blooded animals, the formula I compounds may be formulated as animal feeds, animal feed premixes, animal feed concentrates, pills, solutions, pastes, suspensions, drenches, gels, tablets, boluses and capsules. In addition, the formula I compounds may be administered to the animals in their drinking water. For oral administration, the dosage form chosen should provide the animal with 0.01 mg/kg to 100 mg/kg of animal body weight per day of the formula I compound, preferably with 0.5 mg/kg to 100 mg/kg of animal body weight per day.

- 40 Alternatively, the formula I compounds may be administered to animals parenterally, for example, by intraruminal, intramuscular, intravenous or subcutaneous injection. The formula I compounds may be dispersed or dissolved in a physiologically acceptable

carrier for subcutaneous injection. Alternatively, the formula I compounds may be formulated into an implant for subcutaneous administration. In addition the formula I compound may be transdermally administered to animals. For parenteral administration, the dosage form chosen should provide the animal with 0.01 mg/kg to 100 mg/kg of animal body weight per day of the formula I compound.

The formula I compounds may also be applied topically to the animals in the form of dips, dusts, powders, collars, medallions, sprays, shampoos, spot-on and pour-on formulations and in ointments or oil-in-water or water-in-oil emulsions. For topical application, dips and sprays usually contain 0.5 ppm to 5,000 ppm and preferably 1 ppm to 3,000 ppm of the formula I compound. In addition, the formula I compounds may be formulated as ear tags for animals, particularly quadrupeds such as cattle and sheep.

Suitable preparations are:

- Solutions such as oral solutions, concentrates for oral administration after dilution, solutions for use on the skin or in body cavities, pouring-on formulations, gels;
- Emulsions and suspensions for oral or dermal administration; semi-solid preparations;
- Formulations in which the active compound is processed in an ointment base or in an oil-in-water or water-in-oil emulsion base;
- Solid preparations such as powders, premixes or concentrates, granules, pellets, tablets, boluses, capsules; aerosols and inhalants, and active compound-containing shaped articles.

Compositions suitable for injection are prepared by dissolving the active ingredient in a suitable solvent and optionally adding further ingredients such as acids, bases, buffer salts, preservatives, and solubilizers. The solutions are filtered and filled sterile.

Suitable solvents are physiologically tolerable solvents such as water, alkanols such as ethanol, butanol, benzyl alcohol, glycerol, propylene glycol, polyethylene glycols, N-methyl-pyrrolidone, 2-pyrrolidone, and mixtures thereof.

The active compounds can optionally be dissolved in physiologically tolerable vegetable or synthetic oils which are suitable for injection.

Suitable solubilizers are solvents which promote the dissolution of the active compound in the main solvent or prevent its precipitation. Examples are polyvinylpyrrolidone, polyvinyl alcohol, polyoxyethylated castor oil, and polyoxyethylated sorbitan ester.

Suitable preservatives are benzyl alcohol, trichlorobutanol, p-hydroxybenzoic acid esters, and n-butanol.

5 Oral solutions are administered directly. Concentrates are administered orally after prior dilution to the use concentration. Oral solutions and concentrates are prepared according to the state of the art and as described above for injection solutions, sterile procedures not being necessary.

10 Solutions for use on the skin are trickled on, spread on, rubbed in, sprinkled on or sprayed on.

Solutions for use on the skin are prepared according to the state of the art and according to what is described above for injection solutions, sterile procedures not being necessary.  
15

Further suitable solvents are polypropylene glycol, phenyl ethanol, phenoxy ethanol, ester such as ethyl or butyl acetate, benzyl benzoate, ethers such as alkylene glycol alkylether, e.g. dipropylenglycol monomethylether, ketons such as acetone, methylethylketone, aromatic hydrocarbons, vegetable and synthetic oils, dimethylformamide, dimethylacetamide, transcitol, solketal, propylencarbonate, and mixtures thereof.  
20

It may be advantageous to add thickeners during preparation. Suitable thickeners are inorganic thickeners such as bentonites, colloidal silicic acid, aluminium monostearate, organic thickeners such as cellulose derivatives, polyvinyl alcohols and their copolymers, acrylates and methacrylates.  
25

Gels are applied to or spread on the skin or introduced into body cavities. Gels are prepared by treating solutions which have been prepared as described in the case of the injection solutions with sufficient thickener that a clear material having an ointment-like consistency results. The thickeners employed are the thickeners given above.  
30

Pour-on formulations are poured or sprayed onto limited areas of the skin, the active compound penetrating the skin and acting systemically.  
35

Pour-on formulations are prepared by dissolving, suspending or emulsifying the active compound in suitable skin-compatible solvents or solvent mixtures. If appropriate, other auxiliaries such as colorants, bioabsorption-promoting substances, antioxidants, light stabilizers, adhesives are added.  
40

Suitable solvents which are: water, alkanols, glycols, polyethylene glycols, polypropylene glycols, glycerol, aromatic alcohols such as benzyl alcohol, phenylethanol, phe-

noxyethanol, esters such as ethyl acetate, butyl acetate, benzyl benzoate, ethers such as alkylene glycol alkyl ethers such as dipropylene glycol monomethyl ether, diethylene glycol mono-butyl ether, ketones such as acetone, methyl ethyl ketone, cyclic carbonates such as propylene carbonate, ethylene carbonate, aromatic and/or aliphatic hydrocarbons, vegetable or synthetic oils, DMF, dimethylacetamide, n-alkylpyrrolidones  
5 such as methylpyrrolidone, n-butylpyrrolidone or n-octylpyrrolidone, N-methylpyrrolidone, 2-pyrrolidone, 2,2-dimethyl-4-oxy-methylene-1,3-dioxolane and glycerol formal.

10 Suitable colorants are all colorants permitted for use on animals and which can be dissolved or suspended.

Suitable absorption-promoting substances are, for example, DMSO, spreading oils such as isopropyl myristate, dipropylene glycol pelargonate, silicone oils and copolymers thereof with polyethers, fatty acid esters, triglycerides, fatty alcohols.  
15

Suitable antioxidants are sulfites or metabisulfites such as potassium metabisulfite, ascorbic acid, butylhydroxytoluene, butylhydroxyanisole, tocopherol.

20 Suitable light stabilizers are, for example, novantisolic acid.

Suitable adhesives are, for example, cellulose derivatives, starch derivatives, polyacrylates, natural polymers such as alginates, gelatin.

25 Emulsions can be administered orally, dermally or as injections.

Emulsions are either of the water-in-oil type or of the oil-in-water type.

They are prepared by dissolving the active compound either in the hydrophobic or in the hydrophilic phase and homogenizing this with the solvent of the other phase with  
30 the aid of suitable emulsifiers and, if appropriate, other auxiliaries such as colorants, absorption-promoting substances, preservatives, antioxidants, light stabilizers, viscosity-enhancing substances.

35 Suitable hydrophobic phases (oils) are:

liquid paraffins, silicone oils, natural vegetable oils such as sesame oil, almond oil, castor oil, synthetic triglycerides such as caprylic/capric biglyceride, triglyceride mixture with vegetable fatty acids of the chain length C<sub>8</sub>-C<sub>12</sub> or other specially selected natural fatty acids, partial glyceride mixtures of saturated or unsaturated fatty acids possibly  
40 also containing hydroxyl groups, mono- and diglycerides of the C<sub>8</sub>-C<sub>10</sub> fatty acids, fatty acid esters such as ethyl stearate, di-n-butyryl adipate, hexyl laurate, dipropylene glycol perlargonate, esters of a branched fatty acid of medium chain length with saturated fatty alcohols of chain length C<sub>16</sub>-C<sub>18</sub>, isopropyl myristate, isopropyl palmitate,

caprylic/capric acid esters of saturated fatty alcohols of chain length C<sub>12</sub>-C<sub>18</sub>, isopropyl stearate, oleyl oleate, decyl oleate, ethyl oleate, ethyl lactate, waxy fatty acid esters such as synthetic duck coccygeal gland fat, dibutyl phthalate, diisopropyl adipate, and ester mixtures related to the latter, fatty alcohols such as isotridecyl alcohol, 2-  
5 octyldodecanol, cetylstearyl alcohol, oleyl alcohol, and fatty acids such as oleic acid and mixtures thereof.

Suitable hydrophilic phases are: water, alcohols such as propylene glycol, glycerol, sorbitol and mixtures thereof.

10

Suitable emulsifiers are:

non-ionic surfactants, e.g. polyethoxylated castor oil, polyethoxylated sorbitan monooleate, sorbitan monostearate, glycerol monostearate, polyoxyethyl stearate, alkylphenol polyglycol ether;

15 ampholytic surfactants such as di-sodium N-lauryl-p-iminodipropionate or lecithin; anionic surfactants, such as sodium lauryl sulfate, fatty alcohol ether sulfates, mono/dialkyl polyglycol ether orthophosphoric acid ester monoethanolamine salt; cation-active surfactants, such as cetyltrimethylammonium chloride.

20 Suitable further auxiliaries are: substances which enhance the viscosity and stabilize the emulsion, such as carboxymethylcellulose, methylcellulose and other cellulose and starch derivatives, polyacrylates, alginates, gelatin, gum arabic, polyvinylpyrrolidone, polyvinyl alcohol, copolymers of methyl vinyl ether and maleic anhydride, polyethylene glycols, waxes, colloidal silicic acid or mixtures of the substances mentioned.

25

Suspensions can be administered orally or topically/dermally. They are prepared by suspending the active compound in a suspending agent, if appropriate with addition of other auxiliaries such as wetting agents, colorants, bioabsorption-promoting substances, preservatives, antioxidants, light stabilizers.

30

Liquid suspending agents are all homogeneous solvents and solvent mixtures.

Suitable wetting agents (dispersants) are the emulsifiers given above.

35 Other auxiliaries which may be mentioned are those given above.

Semi-solid preparations can be administered orally or topically/dermally. They differ from the suspensions and emulsions described above only by their higher viscosity.

40 For the production of solid preparations, the active compound is mixed with suitable excipients, if appropriate with addition of auxiliaries, and brought into the desired form.

Suitable excipients are all physiologically tolerable solid inert substances. Those used

are inorganic and organic substances. Inorganic substances are, for example, sodium chloride, carbonates such as calcium carbonate, hydrogencarbonates, aluminium oxides, titanium oxide, silicic acids, argillaceous earths, precipitated or colloidal silica, or phosphates. Organic substances are, for example, sugar, cellulose, foodstuffs and feeds such as milk powder, animal meal, grain meals and shreds, starches.

Suitable auxiliaries are preservatives, antioxidants, and/or colorants which have been mentioned above.

10 Other suitable auxiliaries are lubricants and glidants such as magnesium stearate, stearic acid, talc, bentonites, disintegration-promoting substances such as starch or crosslinked polyvinylpyrrolidone, binders such as starch, gelatin or linear polyvinylpyrrolidone, and dry binders such as microcrystalline cellulose.

15 In general, "parasitically effective amount" means the amount of active ingredient needed to achieve an observable effect on growth, including the effects of necrosis, death, retardation, prevention, and removal, destruction, or otherwise diminishing the occurrence and activity of the target organism. The parasitically effective amount can vary for the various compounds/compositions used in the invention. A parasitically  
20 effective amount of the compositions will also vary according to the prevailing conditions such as desired parasitidal effect and duration, target species, mode of application, and the like.

The compositions which can be used in the invention can comprise generally from  
25 about 0.001 to 95% of the compound of formula I.

Generally it is favorable to apply the compounds of formula I in total amounts of 0.5 mg/kg to 100 mg/kg per day, preferably 1 mg/kg to 50 mg/kg per day.

30 Ready-to-use preparations contain the compounds acting against parasites, preferably ectoparasites, in concentrations of 10 ppm to 80 per cent by weight, preferably from 0.1 to 65 per cent by weight, more preferably from 1 to 50 per cent by weight, most preferably from 5 to 40 per cent by weight.

35 Preparations which are diluted before use contain the compounds acting against ectoparasites in concentrations of 0.5 to 90 per cent by weight, preferably of 1 to 50 per cent by weight.

40 Furthermore, the preparations comprise the compounds of formula I against endoparasites in concentrations of 10 ppm to 2 per cent by weight, preferably of 0.05 to 0.9 per cent by weight, very particularly preferably of 0.005 to 0.25 per cent by weight.

In a preferred embodiment of the present invention, the compositions comprising the compounds of formula I them are applied dermally / topically.

5 In a further preferred embodiment, the topical application is conducted in the form of compound-containing shaped articles such as collars, medallions, ear tags, bands for fixing at body parts, and adhesive strips and foils.

10 Generally it is favorable to apply solid formulations which release compounds of formula I in total amounts of 10 mg/kg to 300 mg/kg, preferably 20 mg/kg to 200 mg/kg, most preferably 25 mg/kg to 160 mg/kg body weight of the treated animal in the course of three weeks.

15 For the preparation of the shaped articles, thermoplastic and flexible plastics as well as elastomers and thermoplastic elastomers are used. Suitable plastics and elastomers are polyvinyl resins, polyurethane, polyacrylate, epoxy resins, cellulose, cellulose derivatives, polyamides and polyester which are sufficiently compatible with the compounds of formula I. A detailed list of plastics and elastomers as well as preparation procedures for the shaped articles is given e.g. in WO 03/086075.

## 20 Examples

The present invention is now illustrated in further details by the following examples, without imposing any limitation thereto.

## 25 S. Synthesis Examples

Synthesis Example S.1:

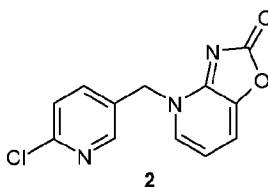

30

To a solution of 2-chloro-5-iodomethyl-pyridine (2.6 g, 10.26 mmol, prepared according to WO2006/060029) in CH<sub>3</sub>CN (50 mL) were added 4H-oxazolo[4,5-b]pyridin-2-one (1.86 g, 13.67 mmol) and K<sub>2</sub>CO<sub>3</sub> (5.67 g, 41.0 mmol) and the suspension was stirred at reflux for 1 h. After cooling to room temperature, solids were removed by filtration and the filtrate was evaporated under reduced pressure. The residue was purified by flash column chromatography (SiO<sub>2</sub>, gradient of MeOH/CH<sub>2</sub>Cl<sub>2</sub>) to yield 0.79 g (3.0 mmol, 29%) of compound E.2 as a colorless solid.

LC-MS: mass calcd. for C<sub>12</sub>H<sub>9</sub>ClN<sub>3</sub>O<sub>2</sub> [M+H]<sup>+</sup> 262.0 found 262.0; t<sub>R</sub> = 1.83 min.

40 Synthesis Example S.2:

83

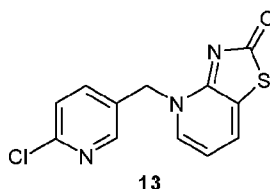

To a solution of 2-chloro-5-iodomethyl-pyridine (0.6 g, 1.97 mmol, prepared according to WO2006/060029) in CH<sub>3</sub>CN (10 mL) were added 3H-thiazolo[4,5-b]pyridin-2-one (0.31 g, 2.04 mmol, prepared according to Bull. Soc. Chim. Fr. 1993, 130, 395) and K<sub>2</sub>CO<sub>3</sub> (1.09 g, 7.89 mmol) and the suspension was stirred at reflux for 2 h. After cooling to room temperature, solids were isolated by filtration and subjected to flash column chromatography (SiO<sub>2</sub>, gradient of MeOH/CH<sub>2</sub>Cl<sub>2</sub>) to yield 90 mg (0.32 mmol, 16%) of compound **13** as a colorless solid.

10

LC-MS: mass calcd. for C<sub>12</sub>H<sub>9</sub>ClN<sub>3</sub>OS [M+H]<sup>+</sup> 278.0 found 278.0; t<sub>R</sub> = 2.00 min.

Synthesis Example S.3:

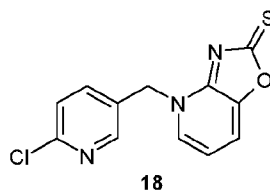

15

A suspension of 2-chloro-5-chloromethyl-pyridine (1.0 g, 6.17 mmol), 2-amino-pyridin-3-ol (0.68 g, 6.17 mmol) and NaI (0.93 g, 6.17 mmol) in acetone (10 mL) was refluxed for 12 h. After cooling to room temperature, solids were removed by filtration and the filtrate was evaporated under reduced pressure. The residue was triturated with ethyl acetate to yield 1.63 g of crude 2-amino-1-(6-chloro-pyridin-3-ylmethyl)-3-hydroxy-pyridinium chloride which was used without further purification.

20

Phenyl chlorothionocarbonate (0.37 g, 2.12 mmol) and Et<sub>3</sub>N (0.32 g, 3.18 mmol) were added to a solution of the crude product (0.5 g) in DMF (3 mL) and the solution was stirred at 70 °C for 5 h. The mixture was diluted with H<sub>2</sub>O and extracted twice with CH<sub>2</sub>Cl<sub>2</sub>. The combined organic phases were dried over Na<sub>2</sub>SO<sub>4</sub> and evaporated under reduced pressure. The residue was triturated with methyl tert-butyl ether and further purified by RP-HPLC to yield 20 mg (0.07 mmol, 3.5%) of compound **E.14** as a yellowish solid.

25

30 LC-MS: mass calcd. for C<sub>12</sub>H<sub>9</sub>ClN<sub>3</sub>OS [M+H]<sup>+</sup> 278.0 found 278.0; t<sub>R</sub> = 2.02 min.

Synthesis Example S.4:

84

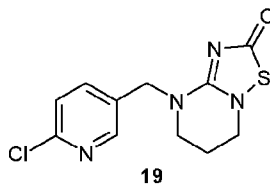

- A solution of 1-(6-Chloro-pyridin-3-ylmethyl)-1,4,5,6-tetrahydro-pyrimidin-2-ylamine (1.0 g, 4.45 mmol, prepared according to J. Med. Chem. 1999, 42 (12), 2231) in dry THF (7.5 mL) was added dropwise to a solution of chloroformylsulfonyl chloride (0.64 g, 4.9 mmol) in dry THF (7.5 mL) at  $-5^{\circ}\text{C}$ . The solution was then stirred at reflux for 2 h. After cooling to room temperature, solids were removed by filtration and the filtrate was evaporated under reduced pressure. The residue was purified by RP-HPLC to yield 90 mg (0.32 mmol, 7%) of compound **E.15**.
- LC-MS: mass calcd. for  $\text{C}_{11}\text{H}_{12}\text{ClN}_4\text{OS}$   $[\text{M}+\text{H}]^+$  283.0 found 283.0;  $t_{\text{R}} = 2.43$  min.

## Synthesis Example S.5:

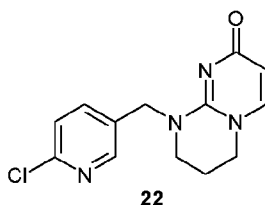

- A solution of 1-(6-chloro-pyridin-3-ylmethyl)-1,4,5,6-tetrahydro-pyrimidin-2-ylamine (200 mg, 0.89 mmol, prepared according to J. Med. Chem. 1999, 42, 2227-2234) and ethyl propiolate (175 mg, 1.78 mmol) in *m*-xylene (3 mL) was stirred at  $80^{\circ}\text{C}$  for 3.5 h. The solvent was then removed under reduced pressure and the residue was purified by flash column chromatography ( $\text{SiO}_2$ , gradient of  $\text{MeOH}/\text{CH}_2\text{Cl}_2$ ) to yield 15 mg (0.05 mmol, 6%) of compound **E.22**.
- LC-MS: mass calcd. for  $\text{C}_{13}\text{H}_{14}\text{ClN}_4\text{O}$   $[\text{M}+\text{H}]^+$  277.1 found 277.1;  $t_{\text{R}} = 1.61$  min.

## Synthesis Example S.6:

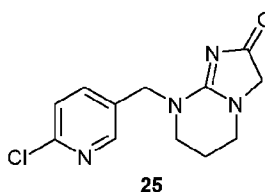

- A solution of 1-(6-chloro-pyridin-3-ylmethyl)-1,4,5,6-tetrahydro-pyrimidin-2-ylamine (250 mg, 1.11 mmol) and ethyl bromoacetate (185 mg, 1.12 mmol) in pyridine (5 mL) was stirred at  $80^{\circ}\text{C}$  for 5 h. A second equivalent of ethyl bromoacetate was added and stirring was continued at  $80^{\circ}\text{C}$  for additional 4 h. The solvent was removed under reduced pressure and the residue was purified by RP-HPLC to yield 20 mg (0.05 mmol, 5%) of compound **E.25** as the TFA salt.

LC-MS: mass calcd. for C<sub>12</sub>H<sub>14</sub>ClN<sub>4</sub>O [M+H]<sup>+</sup> 265.1 found 265.0; t<sub>R</sub> = 1.29 min.

C. Compound examples

- 5 Compound examples of the present invention are shown in the synthesis examples above.

10 Examples of compounds of formula I according to the present invention are given in table E.1 below. The Compound examples can be characterized e.g. by coupled High Performance Liquid Chromatography / mass spectrometry (HPLC/MS).

Analytical HPLC column: RP-18 column Chromolith Speed ROD from Merck KgaA, Germany). Elution: acetonitrile + 0.1% trifluoroacetic acid (TFA) / water + 0.1% trifluoroacetic acid (TFA) in a ratio of from 5:95 to 95:5 in 5 minutes at 40 °C.

- 15 \*)Analytical UPLC column: Phenomenex Kinetex 1.7 μm XB-C18 100A; 50 x 2.1 mm; mobile phase: A: water + 0.1% trifluoroacetic acid (TFA); B: acetonitrile + 0.1% TFA; gradient: 5-100% B in 1.50 minutes; 100% B 0.20 min; flow: 0.8-1.0mL/min in 1.50 minutes at 60°C.

MS-method: ESI positive.

20

Table E.1 Examples of compounds according to formula I-E1:

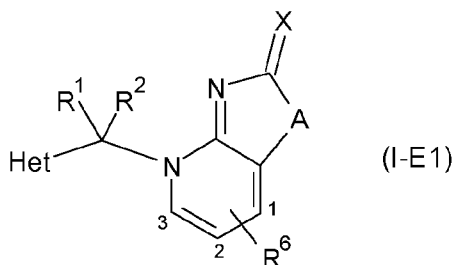

25

No.	Het <sup>a)</sup>	R <sup>1</sup>	R <sup>2</sup>	A	X	R <sup>6</sup>	Physico-chemical data <sup>b)</sup>
E1.1		H	H	O	O	H	r.t. = 1.59 min m/z = 245.4
E1.2		H	H	O	O	H	r.t. = 1.83 min m/z = 262.0
E1.3		H	H	O	O	H	r.t. = 1.96 min m/z = 307.9
E1.4		H	H	O	O	H	r.t. = 2.07 min m/z = 279.4

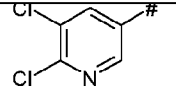
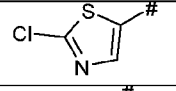
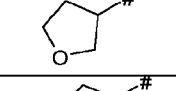
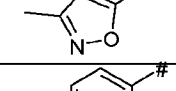
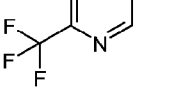
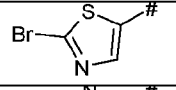
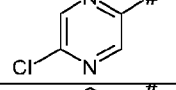
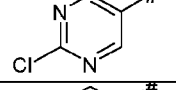
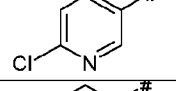
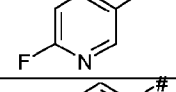
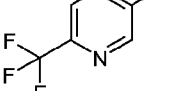
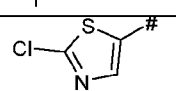
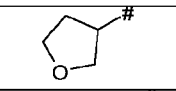
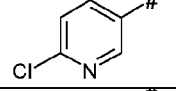
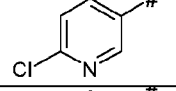
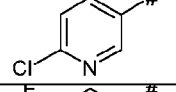
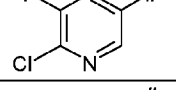
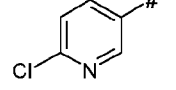
No.	Het <sup>a)</sup>	R <sup>1</sup>	R <sup>2</sup>	A	X	R <sup>6</sup>	Physico-chemical data <sup>b)</sup>
E1.5		H	H	O	O	H	r.t. = 2.25 min m/z = 296.9
E1.6		H	H	O	O	H	r.t. = 1.93 min m/z = 267.9
E1.7		H	H	O	O	H	r.t. = 1.35 min m/z = 221.0
E1.8		H	H	O	O	H	r.t. = 1.41 min m/z = 232.0
E1.9		H	H	O	O	H	r.t. = 2.14 min m/z = 296.1
E1.10		H	H	O	O	H	r.t. = 1.84 min m/z = 313.8
E1.11		H	H	O	O	H	r.t. = 1.64 min m/z = 263.0
E1.12		H	H	O	O	H	r.t. = 1.47 min m/z = 262.9
E1.13		H	H	S	O	H	r.t. = 2.00 min m/z = 278.0
E1.14		H	H	S	O	H	r.t. = 1.77 min m/z = 262.0
E1.15		H	H	S	O	H	r.t. = 2.23 min m/z = 312.0
E1.16		H	H	S	O	H	r.t. = 2.05 min m/z = 206.0
E1.17		H	H	S	O	H	r.t. = 1.54 min m/z = 237.1
E1.18		H	H	O	S	H	r.t. = 2.02 min m/z = 278.0
E1.19		H	H	NH	O	H	r.t. = 1.27 min m/z = 261.0
E1.20		H	H	O	O	2-F	r.t. = 1.90 min m/z = 279.9
E1.21		H	H	S	O	H	r.t. = 2.43 min m/z = 296.0
E1.22		H	H	O	O	2-Cl	r.t. = 2.17 min m/z = 297.0

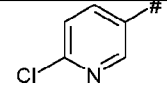
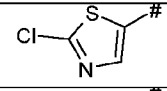
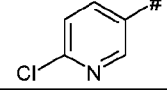
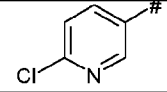
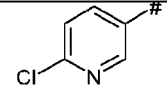
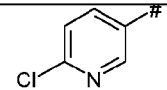
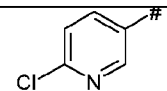
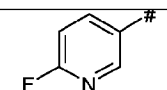
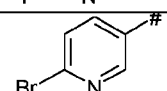
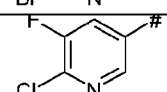
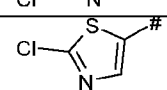
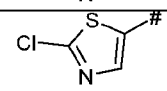
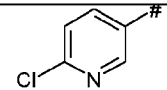
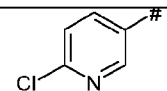
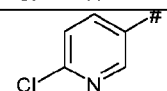
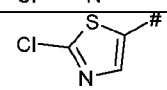
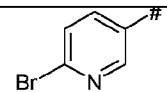
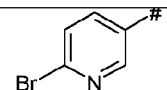
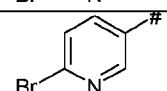
No.	Het <sup>a)</sup>	R <sup>1</sup>	R <sup>2</sup>	A	X	R <sup>6</sup>	Physico-chemical data <sup>b)</sup>
E1.23		H	H	O	O	2-Br	r.t. = 2.25 min m/z = 341.8
E1.24		H	H	O	S	H	r.t. = 2.12 min m/z = 284.0
E1.25		H	H	O	O	2,3-di-Cl	r.t. = 2.56 min m/z = 331.0
E1.26		H	H	O	O	2,3-di-Br	r.t. = 2.71 min m/z = 420.8
E1.27		H	H	O	O	2-CH <sub>3</sub>	r.t. = 1.98 min m/z = 276.0
E1.28		H	H	O	S	2-CH <sub>3</sub>	r.t. = 2.22 min m/z = 292.0
E1.29		H	H	O	S	2-F	r.t. = 2.18 min m/z = 295.9
E1.30		H	H	O	S	H	r.t. = 1.72 min m/z = 262.0
E1.31		H	H	O	S	H	r.t. = 2.09 min m/z = 321.9
E1.32		H	H	O	S	H	r.t. = 2.27 min m/z = 296.0
E1.33		H	H	O	O	2-CH <sub>3</sub>	r.t. = 1.12 min <sup>*)</sup> m/z = 282.0
E1.34		H	H	O	O	2-F	r.t. = 0.78 min <sup>*)</sup> m/z = 285.9
E1.35		H	H	S	S	H	r.t. = 0.81 min <sup>*)</sup> m/z = 293.9
E1.36		H	H	S	S	2-CH <sub>3</sub>	r.t. = 0.87 min <sup>*)</sup> m/z = 308.0
E1.37		H	H	S	S	2-Br	r.t. = 0.96 min <sup>*)</sup> m/z = 373.8
E1.38		H	H	O	S	2-CH <sub>3</sub>	r.t. = 0.84 min <sup>*)</sup> m/z = 297.9
E1.39		H	H	O	S	2-CH <sub>3</sub>	r.t. = 0.84 min <sup>*)</sup> m/z = 337.8
E1.40		H	H	O	O	2-CH <sub>3</sub>	r.t. = 0.80 min <sup>*)</sup> m/z = 321.9
E1.41		H	H	O	S	2-F	r.t. = 0.83 min <sup>*)</sup> m/z = 339.9

No.	Het <sup>a)</sup>	R <sup>1</sup>	R <sup>2</sup>	A	X	R <sup>6</sup>	Physico-chemical data <sup>b)</sup>
E1.42		H	H	S	S	H	r.t. = 0.88 min <sup>*)</sup> m/z = 312.0
E1.43		H	H	O	S	1- CH <sub>3</sub>	r.t. = 0.81 min <sup>*)</sup> m/z = 292.2
E1.44		H	H	O	O	1- CH <sub>3</sub>	r.t. = 0.76 min <sup>*)</sup> m/z = 276.2
E1.45		H	H	S	S	2- CH <sub>3</sub>	r.t. = 0.89 min <sup>*)</sup> m/z = 313.9
E1.46		H	H	S	S	H	r.t. = 0.83 min <sup>*)</sup> m/z = 299.9
E1.47		H	H	S	S	2- CH <sub>3</sub>	r.t. = 0.93 min <sup>*)</sup> m/z = 326.0

a) # denotes the attachment point to the remainder of the molecule;

b) r.t. = HPLC retention time; m/z of the [M+H]<sup>+</sup>, [M+Na]<sup>+</sup> or [M+K]<sup>+</sup> peaks.

\*) analytical UPLC column (see above)

5 Table E.2 Examples of compounds according to formula I-E2:

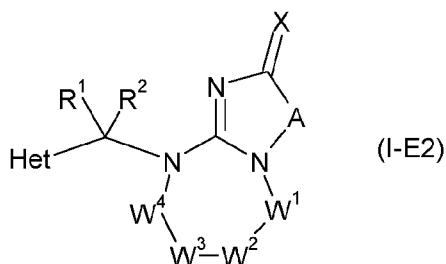

No.	Het <sup>a)</sup>	R <sup>1</sup>	R <sup>2</sup>	W <sup>4</sup> -W <sup>3</sup> -W <sup>2</sup> -W <sup>1</sup>	A	X	Physico-chemical data <sup>b)</sup>
E2.1		H	H	-CH <sub>2</sub> -CH <sub>2</sub> -CH <sub>2</sub> -	S	O	r.t. = 2.43 min m/z = 283.0
E2.2		H	H	-CH <sub>2</sub> -CH <sub>2</sub> -	S	O	r.t. = 2.20 min m/z = 269.0
E2.3		H	H	-CH=CH-	S	O	r.t. = 2.52 min m/z = 304.9
E2.4		H	H	-CH <sub>2</sub> -CH <sub>2</sub> -CH <sub>2</sub> -	-CH=CH-	O	r.t. = 1.61 min m/z = 277.1

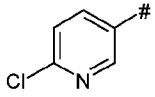
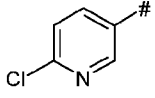
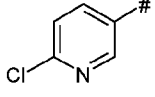
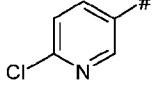
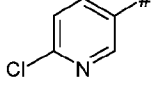
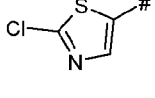
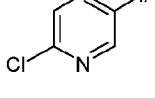
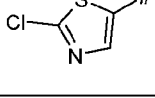
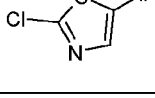
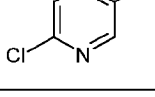
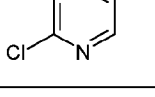
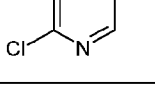
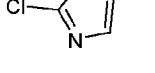
No.	Het <sup>a)</sup>	R1	R2	W <sup>4</sup> -W <sup>3</sup> -W <sup>2</sup> -W <sup>1</sup>	A	X	Physico-chemical data <sup>b)</sup>
E2.5		H	H	-CH <sub>2</sub> -CH <sub>2</sub> -	-CH=CH-	O	r.t. = 1.44 min m/z = 263.1
E2.6		H	H	-CH=CH-	-CH=CH-	O	r.t. = 1.50 min m/z = 261.0
E2.7		H	H	-CH <sub>2</sub> -CH <sub>2</sub> -CH <sub>2</sub> -	CH <sub>2</sub>	O	r.t. = 1.29 min m/z = 265.0
E2.8		H	H	-CH <sub>2</sub> -CH <sub>2</sub> -	O	O	r.t. = 1.71 min m/z = 253.0
E2.9		H	H	-CH <sub>2</sub> -CH <sub>2</sub> -CH <sub>2</sub> -	O	O	r.t. = 0.704 min <sup>*)</sup> m/z = 267.0
E2.10		H	H	-CH <sub>2</sub> -CH <sub>2</sub> -CH <sub>2</sub> -	O	O	r.t. = 0.723 min <sup>*)</sup> m/z = 272.9
E2.11		H	H	-CH <sub>2</sub> -CH <sub>2</sub> -CH <sub>2</sub> -	O	S	r.t. = 2.102 min m/z = 283.1
E2.12		H	H	-CH <sub>2</sub> -CH <sub>2</sub> -	O	O	r.t. = 1.837 min m/z = 259.0
E2.13		H	H	-CH <sub>2</sub> -CH <sub>2</sub> -CH <sub>2</sub> -	O	S	r.t. = 0.723 min <sup>*)</sup> m/z = 272.9
E2.14		H	H	-CH <sub>2</sub> -O-CH <sub>2</sub> -	S	O	r.t. = 0.852 min <sup>*)</sup> m/z = 285.2
E2.15		H	H	-CH <sub>2</sub> -CH <sub>2</sub> -CH <sub>2</sub> -	O	S	r.t. = 0.922 min <sup>*)</sup> m/z = 317.2
E2.16		H	H	-CH <sub>2</sub> -CH <sub>2</sub> -CH <sub>2</sub> -	O	O	r.t. = 0.848 min <sup>*)</sup> m/z = 301.2
E2.17		H	H	-CH <sub>2</sub> -O-CH <sub>2</sub> -	S	O	r.t. = 0.905 min <sup>*)</sup> m/z = 291.2

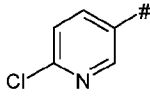
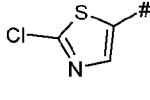
No.	Het <sup>a)</sup>	R1	R2	W <sup>4</sup> -W <sup>3</sup> -W <sup>2</sup> -W <sup>1</sup>	A	X	Physico-chemical data <sup>b)</sup>
E2.18		H	H	-CH=CH-N=	S	O	r.t. = 0.767 min <sup>*)</sup> m/z = 279.2
E2.19		H	H	-CH=CH-N=	S	O	r.t. = 0.794 min <sup>*)</sup> m/z = 285.2

a) # denotes the attachment point to the remainder of the molecule;

b) r.t. = HPLC retention time; m/z of the [M+H]<sup>+</sup>, [M+Na]<sup>+</sup> or [M+K]<sup>+</sup> peaks.

\*) analytical UPLC column

- 5 Compounds can in general be characterized e.g. by coupled High Performance Liquid Chromatography / mass spectrometry (HPLC/MS), by <sup>1</sup>H-NMR and/or by their melting points.

#### B. Biological examples

10

The biological activity of the compounds of formula I of the present invention can or could be demonstrated and evaluated in biological tests as described in the following.

#### General conditions

15

If not otherwise specified, most test solutions are prepared as follows:

The active compound is dissolved at the desired concentration in a mixture of 1:1 (vol:vol) distilled water : acetone. The test solutions are prepared at the day of use (and, if not otherwise specified, in general at concentrations wt/vol).

20

#### B.1 Green Peach Aphid (*Myzus persicae*)

25 The active compounds were formulated in cyclohexanone as a 10,000 ppm solution supplied in tubes. The tubes were inserted into an automated electrostatic sprayer equipped with an atomizing nozzle and they served as stock solutions for which lower dilutions were made in 50% acetone:50% water (v/v). A nonionic surfactant (Kinetic®) was included in the solution at a volume of 0.01% (v/v).

30 Bell pepper plants at the first true-leaf stage were infested prior to treatment by placing heavily infested leaves from the main colony on top of the treatment plants. Aphids were allowed to transfer overnight to accomplish an infestation of 30-50 aphids per plant and the host leaves were removed. The infested plants were then sprayed by an automated electrostatic plant sprayer equipped with an atomizing spray nozzle. The plants were dried in the sprayer fume hood, removed, and then maintained in a growth

room under fluorescent lighting in a 24-hr photoperiod at about 25°C and about 20-40% relative humidity. Aphid mortality on the treated plants, relative to mortality on untreated control plants, was determined after 5 days.

5

In this test, compounds E1.1, E1.2, E1.3, E1.4, E1.5, E1.6, E1.8, E1.12, E1.14, E1.18, E1.20, E1.21, E1.24, E1.28, E1.30, E1.31, E1.32, E1.35, E1.36, E1.40, E1.41, E2.3, E2.9, E2.10, E2.11, E2.12, E2.13, E2.15 and E2.16 at 300 ppm showed at least 75 % mortality in comparison with untreated controls.

10

#### B.2 Cotton aphid (*Aphis gossypii*)

The active compounds were formulated in 50:50 (vol:vol) acetone : water and 100 ppm Kinetica™ surfactant.

15

Cotton plants at the cotyledon stage (one plant per pot) were infested by placing a heavily infested leaf from the main colony on top of each cotyledon. The aphids were allowed to transfer to the host plant overnight, and the leaf used to transfer the aphids was removed. The cotyledons were dipped in the test solution and allowed to dry. After

20

5 days, mortality counts were made.

In this test, compounds E1.1, E1.2, E1.3, E1.4, E1.6, E1.8, E1.12, E1.18, E1.21, E1.24, E1.30, E1.31, E1.32, E1.35, E1.42, E2.9, E2.10, E2.11, E2.13 and E2.16 at 300 ppm showed at least 75 % mortality in comparison with untreated controls.

25

#### B.3 Cowpea aphid (*Aphis craccivora*)

The active compound is dissolved at the desired concentration in a mixture of 1:1 (vol:vol) distilled water : acetone. The test solution is prepared at the day of use.

30

Potted cowpea plants colonized with approximately 100 - 150 aphids of various stages were sprayed after the pest population has been recorded. Population reduction was assessed after 24, 72, and 120 hours.

35

In this test, compounds E1.1, E1.2, E1.3, E1.4, E1.6, E1.7, E1.8, E1.9, E1.10, E1.11, E1.13, E1.14, E1.16, E1.18, E1.20, E1.21, E1.22, E1.23, E1.24, E1.25, E1.26, E1.27, E1.28, E1.30, E1.31, E1.32, E1.35, E1.38, E1.39, E1.41, E1.42, E1.44, E1.45, E1.46, E2.8, E2.9, E2.10, E2.11, E2.12, E2.13, E2.15 and E2.16 at 500 ppm showed at least 75 % mortality in comparison with untreated controls.

40

#### B.4 Vetch aphid (*Megoura viciae*)

For evaluating control of vetch aphid (*Megoura viciae*) through contact or systemic means the test unit consisted of 24-well-microtiter plates containing broad bean leaf disks.

5 The compounds were formulated using a solution containing 75% v/v water and 25% v/v DMSO. Different concentrations of formulated compounds were sprayed onto the leaf disks at 2.5 µl, using a custom built micro atomizer, at two replications.

10 After application, the leaf disks were air-dried and 5 – 8 adult aphids placed on the leaf disks inside the microtiter plate wells. The aphids were then allowed to suck on the treated leaf disks and incubated at about 23 ± 1°C and about 50 ± 5 % relative humidity for 5 days. Aphid mortality and fecundity was then visually assessed.

15 In this test, compounds E1.1, E1.2, E1.3, E1.4, E1.5, E1.6, E1.8, E1.9, E1.10, E1.11, E1.12, E1.13, E1.14, E1.15, E1.16, E1.18, E1.19, E1.21, E1.22, E1.23, E1.24, E1.27, E1.28, E1.30, E1.31, E1.32, E1.33, E1.35, E1.36, E1.37, E1.38, E1.40, E1.41, E1.42, E1.43, E1.44, E1.46, E1.47, E2.3, E2.7, E2.8, E2.9, E2.10, E2.11, E2.13, E2.15, E2.16, E2.18 at 800 ppm showed at least 75 % mortality in comparison with untreated controls.

#### 20 B.5 Silverleaf whitefly (*bemisia argentifolii*)

The active compounds were formulated in cyclohexanone as a 10,000 ppm solution supplied in tubes. The tubes were inserted into an automated electrostatic sprayer equipped with an atomizing nozzle and they served as stock solutions for which lower dilutions were made in 50% acetone:50% water (v/v). A nonionic surfactant (Kinetic®) was included in the solution at a volume of 0.01% (v/v).

30 Cotton plants at the cotyledon stage (one plant per pot) were sprayed by an automated electrostatic plant sprayer equipped with an atomizing spray nozzle. The plants were dried in the sprayer fume hood and then removed from the sprayer. Each pot was placed into a plastic cup and about 10 to 12 whitefly adults (approximately 3-5 days old) were introduced. The insects were collected using an aspirator and a nontoxic Tygon® tubing connected to a barrier pipette tip. The tip, containing the collected insects, was then gently inserted into the soil containing the treated plant, allowing insects to crawl out of the tip to reach the foliage for feeding. Cups were covered with a reusable screened lid. Test plants were maintained in a growth room at about 25°C and about 20-40% relative humidity for 3 days, avoiding direct exposure to fluorescent light (24 hour photoperiod) to prevent trapping of heat inside the cup. Mortality was assessed 3 days after treatment, compared to untreated control plants.

40 In this test, compounds E1.1, E1.2, E1.3, E1.4, E1.7, E1.12, E1.14, E1.16, E1.18, E1.20, E1.24, E1.30, E1.31, E1.32, E1.35, E1.41, E1.42, E2.9, E2.10, E2.11, E2.12, E2.13 and E2.15 at 500 ppm showed at least 75 % mortality in comparison with untreated controls.

#### B.6 Boll weevil (*Anthonomus grandis*)

For evaluating control of boll weevil (*Anthonomus grandis*) the test unit consisted of 24-well-microtiter plates containing an insect diet and 20-30 *A. grandis* eggs.

The compounds were formulated using a solution containing 75% v/v water and 25% v/v DMSO. Different concentrations of formulated compounds were sprayed onto the insect diet at 20 µl, using a custom built micro atomizer, at two replications.

After application, microtiter plates were incubated at about 23 ± 1°C and about 50 ± 5 % relative humidity for 5 days. Egg and larval mortality was then visually assessed.

In this test, compounds E1.1, E1.2, E1.4, E1.5, E1.6, E1.10, E1.12, E1.13, E1.14, E1.16, E1.18, E1.21, E1.24, E1.25, E1.27, E1.30, E1.31, E1.32, E1.33, E1.35, E1.36, E1.37, E1.42, E1.43, E1.45, E1.46, E2.9, E2.10, E2.11, E2.13, E2.15 and E2.16 at 2500 ppm showed over 75 % mortality in comparison with untreated controls.

#### B.7 Orchid thrips (*dichromothrips corbetti*)

*Dichromothrips corbetti* adults used for bioassay were obtained from a colony maintained continuously under laboratory conditions. For testing purposes, the test compound was diluted to a concentration of 300 ppm (wt compound: vol diluent) in a 1:1 mixture of acetone:water (vol:vol), plus 0.01% vol/vol Kinetic® surfactant.

Thrips potency of each compound was evaluated by using a floral-immersion technique. Plastic petri dishes were used as test arenas. All petals of individual, intact orchid flowers were dipped into treatment solution and allowed to dry. Treated flowers were placed into individual petri dishes along with 10 - 15 adult thrips. The petri dishes were then covered with lids. All test arenas were held under continuous light and a temperature of about 28°C for duration of the assay. After 4 days, the numbers of live thrips were counted on each flower, and along inner walls of each petri dish. The level of thrips mortality was extrapolated from pre-treatment thrips numbers.

In this test, compounds E1.1, E1.2, E1.3, E1.4, E1.6, E1.7, E1.8, E1.10, E1.11, E1.14, E1.16, E1.18, E1.20, E1.21, E1.24, E1.28, E1.30, E1.31, E1.32, E1.35, E1.36, E1.38, E1.42, E1.43, E1.46, E2.8, E2.9, E2.10, E2.11, E2.12 and E2.13 at 500 ppm showed at least 75 % mortality in comparison with untreated controls.

#### B.8 Rice green leafhopper (*Nephotettix virescens*)

Rice seedlings were cleaned and washed 24 hours before spraying. The active compounds were formulated in 50:50 acetone:water (vol:vol), and 0.1% vol/vol surfactant (EL 620) was added. Potted rice seedlings were sprayed with 5 ml test solution, air dried, placed in cages and inoculated with 10 adults. Treated rice plants were kept at

about 28-29°C and relative humidity of about 50-60%. Percent mortality was recorded after 72 hours.

5 In this test, compounds E1.1, E1.2, E1.3, E1.4, E1.5, E1.6, E1.8, E1.13, E1.16, E1.18, E1.21, E1.24, E1.30, E.1.31, E1.32, E1.35, E1.42, E1.43, E1.46, E2.9, E2.10, E2.11 and E2.13 at 500 ppm showed at least 75 % mortality in comparison with untreated controls.

#### 10 B.9 Rice brown plant hopper (*Nilaparvata lugens*)

Rice seedlings were cleaned and washed 24 hours before spraying. The active compounds were formulated in 50:50 acetone:water (vol:vol) and 0.1% vol/vol surfactant (EL 620) was added. Potted rice seedlings were sprayed with 5 ml test solution, air dried, placed in cages and inoculated with 10 adults. Treated rice plants were kept at 15 about 28-29°C and relative humidity of about 50-60%. Percent mortality was recorded after 72 hours.

In this test, compounds E1.2, E1.3, E1.4, E1.5, E1.19, E1.24, E1.28, E1.30, E.1.31, E1.32, E1-35, E1.42, E1.43, E2.9, E2.11 and E2.13 at 500 ppm showed at least 75 % 20 mortality in comparison with untreated controls.

#### B.10 Mediterranean fruitfly (*Ceratitis capitata*)

For evaluating control of Mediterranean fruitfly (*Ceratitis capitata*) the test unit consisted of microtiter plates containing an insect diet and 50-80 *C. capitata* eggs. 25 The compounds were formulated using a solution containing 75% v/v water and 25% v/v DMSO. Different concentrations of formulated compounds were sprayed onto the insect diet at 5 µl, using a custom built micro atomizer, at two replications. After application, microtiter plates were incubated at about 28 ± 1°C and about 80 ± 5 30 % relative humidity for 5 days. Egg and larval mortality was then visually assessed.

In this test, compounds E1.1, E1.2, E1.3, E1.6, E1.10, E1.16, E1.18, E1.23, E1.24, E1.30, E1.31, E1.42, E2.9, E2.10, E2.11 and E2.15 at 800 ppm showed over 75 % mortality in comparison with untreated controls.

35

We claim:

1. N-substituted hetero-bicyclic compounds of formula (I)

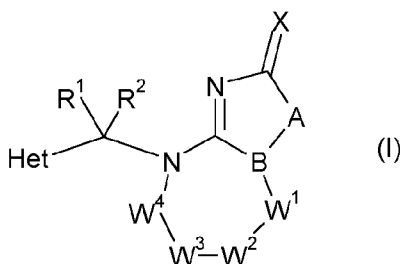

5

wherein

X is O or S;

10

A is selected from group consisting of O, S, NR<sup>3</sup>, CR<sup>4</sup>R<sup>5</sup>, A<sup>1a</sup>-A<sup>1b</sup> and A<sup>2a</sup>=A<sup>2b</sup>, wherein

A<sup>1a</sup>, A<sup>1b</sup> are each selected from O, S, NR<sup>3</sup> or CR<sup>4</sup>R<sup>5</sup>,

under the proviso that

15

A<sup>1a</sup> and A<sup>1b</sup> do not represent O and/or S at the same time,

and

A<sup>2a</sup>, A<sup>2b</sup> are independently from one another N or CR<sup>6</sup>;

B is N or CR<sup>7</sup>;

20

W<sup>1</sup>, W<sup>2</sup>, W<sup>3</sup>

and W<sup>4</sup> represent a chain group connected to N and B, and thus forming a saturated or unsaturated 5-, 6- or 7-membered heterocycle, wherein

25

W<sup>1</sup>, W<sup>2</sup>, W<sup>3</sup> and W<sup>4</sup> each individually represent

CR<sup>6</sup>, CR<sup>4</sup>R<sup>5</sup>, N, NR<sup>3</sup>, O, S(O)<sub>n</sub> or C=Y, wherein

Y is selected from C(R<sup>6</sup>)<sub>2</sub>, O, S or NR<sup>3</sup>, and

wherein

W<sup>2</sup> and W<sup>3</sup> may further represent each individually, or both together,

30

a single or double bond;

and under the proviso that

- (i) not more than two of  $W^1$ ,  $W^2$ ,  $W^3$  and  $W^4$  represent  
O,  $NR^3$ ,  $S(O)_n$  or  $C=Y$  at the same time,  
and/or
- (ii) if two of  $W^1$ ,  $W^2$ ,  $W^3$  and  $W^4$  represent  
O or  $S(O)_n$ , then at least one carbon atom is present between them;
- 5
- Het is a 5 or 6 membered C-bound saturated, unsaturated or aromatic heterocycle, having at least one heteroatom group, selected from O, S and  $N-R^3$ , as ring member and optionally 1 or 2 further N atoms as ring member, wherein
- 10 the heterocycle is unsubstituted or carries at its carbon atoms 1 or 2 radicals  $R^8$ , wherein
- $R^8$  is selected from the group consisting of hydrogen, halogen,  $C_1$ - $C_6$ -alkyl,  $C_3$ - $C_6$ -cycloalkyl,  $C_2$ - $C_6$ -alkenyl,  $C_2$ - $C_6$ -alkynyl,  $C_1$ - $C_6$ -alkoxy,  $C_2$ - $C_6$ -alkenyloxy,  $C_2$ - $C_6$ -alkynyloxy,  $C_1$ - $C_4$ -alkylthio, CN,  $NO_2$ ,  $S(O)_mR^c$ ,  $C(O)R^c$ ,  $C(O)OR^a$ ,  $C(O)NR^aR^b$  and  $C(S)NR^aR^b$ , wherein the aforementioned alkyl, cycloalkyl, alkenyl, alkynyl, alkoxy, alkylthio, alkenyloxy and alkynyloxy radicals are unsubstituted, partly or completely halogenated or may carry any
- 15 combination of 1, 2 or 3 radicals  $R^d$ ;
- 20
- $R^1$ ,  $R^2$  are selected independently from one another from the group consisting of hydrogen, halogen,  $C_1$ - $C_6$ -alkyl,  $C_3$ - $C_6$ -cycloalkyl,  $C_2$ - $C_6$ -alkenyl,  $C_2$ - $C_6$ -alkynyl,  $C_1$ - $C_6$ -alkoxy,  $C_1$ - $C_6$ -alkylthio, CN,  $NO_2$ ,  $C(O)R^c$ ,  $C(O)OR^a$ ,  $C(O)NR^aR^b$ ,  $C(S)NR^aR^b$  and  $S(O)_mR^c$ , wherein the aforementioned alkyl, cycloalkyl, alkenyl, alkynyl, alkoxy and alkylthio radicals are unsubstituted, partly or completely halogenated or may carry any combination of 1, 2 or 3 radicals  $R^d$ ; or
- 25  $R^1$  and  $R^2$  from, together with the carbon atom, which they attached to, a 3- to 6-membered saturated carbocycle, wherein each of the carbon atoms of said carbocycle are unsubstituted or may carry any combination of 1 or 2 radicals  $R^d$ .
- 30
- $R^3$  is selected, and if more than one  $R^3$  is present, independently from one another, from the group consisting of hydrogen,  $C_1$ - $C_6$ -alkyl,  $C_1$ - $C_6$ -haloalkyl,  $C_3$ - $C_6$ -cycloalkyl,  $C_2$ - $C_6$ -alkenyl,  $C_2$ - $C_6$ -haloalkenyl,  $C_2$ - $C_6$ -alkynyl,  $C_2$ - $C_6$ -
- 35

haloalkynyl, C(O)R<sup>c</sup>, C(S)R<sup>c</sup>, C(O)OR<sup>a</sup>, C(O)NR<sup>a</sup>R<sup>b</sup>, C(S)NR<sup>a</sup>R<sup>b</sup> and S(O)<sub>m</sub>R<sup>c</sup> and S(O)<sub>m</sub>NR<sup>a</sup>R<sup>b</sup>, and wherein the aforementioned alkyl, cycloalkyl, alkenyl and alkynyl radicals are unsubstituted or may carry any combination of 1, 2 or 3 radicals R<sup>d</sup>,

5

R<sup>4</sup>, R<sup>5</sup> are independently from one another selected from the group consisting of hydrogen, halogen, C<sub>1</sub>-C<sub>6</sub>-alkyl, C<sub>3</sub>-C<sub>6</sub>-cycloalkyl, C<sub>2</sub>-C<sub>6</sub>-alkenyl and C<sub>2</sub>-C<sub>6</sub>-alkynyl, wherein

10

the aforementioned alkyl, cycloalkyl, alkenyl and alkynyl radicals are unsubstituted, partly or completely halogenated or may carry any combination of 1, 2 or 3 radicals R<sup>d</sup>;

R<sup>6</sup>

15

is selected, and if more than one R<sup>6</sup> is present, independently from one another, from the group consisting of hydrogen, halogen, C<sub>1</sub>-C<sub>6</sub>-alkyl, C<sub>1</sub>-C<sub>6</sub>-alkoxy and C<sub>1</sub>-C<sub>6</sub>-alkylthio, wherein the carbon atoms of the aforementioned radicals are unsubstituted, partly or completely halogenated or may carry any combination of 1, 2 or 3 radicals R<sup>d</sup>;

R<sup>7</sup>

20

has one of the meanings given for R<sup>6</sup>,  
or  
R<sup>7</sup> represents a bond to the neighboring atom W<sup>1</sup> such that B and W<sup>1</sup> are connected by a double bond, under the proviso, that in this case W<sup>1</sup> does not represent CR<sup>4</sup>R<sup>5</sup>, NR<sup>3</sup>, O, S(O)<sub>n</sub> or C=Y;

25

R<sup>a</sup>, R<sup>b</sup>

are selected independently from one another from the group consisting of hydrogen, C<sub>1</sub>-C<sub>4</sub>-alkyl, C<sub>1</sub>-C<sub>4</sub>-haloalkyl, C<sub>3</sub>-C<sub>6</sub>-cycloalkyl, C<sub>3</sub>-C<sub>6</sub>-alkenyl, C<sub>3</sub>-C<sub>6</sub>-haloalkenyl and C<sub>3</sub>-C<sub>6</sub>-alkynyl;

R<sup>c</sup>

30

is selected from the group consisting of C<sub>1</sub>-C<sub>4</sub>-alkyl, C<sub>1</sub>-C<sub>4</sub>-haloalkyl, C<sub>3</sub>-C<sub>6</sub>-cycloalkyl, C<sub>2</sub>-C<sub>6</sub>-alkenyl, C<sub>2</sub>-C<sub>6</sub>-haloalkenyl and C<sub>2</sub>-C<sub>6</sub>-alkynyl;

R<sup>d</sup>

35

is selected from the group consisting of halogen, C<sub>1</sub>-C<sub>4</sub>-alkyl, C<sub>3</sub>-C<sub>6</sub>-cycloalkyl, C<sub>2</sub>-C<sub>6</sub>-alkenyl, C<sub>2</sub>-C<sub>6</sub>-alkynyl, C<sub>1</sub>-C<sub>4</sub>-alkoxy, C<sub>2</sub>-C<sub>6</sub>-alkenyloxy, C<sub>2</sub>-C<sub>6</sub>-alkynyloxy, C<sub>1</sub>-C<sub>4</sub>-alkylthio, C<sub>1</sub>-C<sub>4</sub>-alkoxy-C<sub>1</sub>-C<sub>4</sub>-alkyl, C<sub>1</sub>-C<sub>4</sub>-alkylthio-C<sub>1</sub>-C<sub>4</sub>-alkyl, wherein all carbon atoms of the aforementioned 10 radicals are unsubstituted or may be partially of

fully halogenated, NO<sub>2</sub>, CN, NR<sup>e</sup>R<sup>f</sup>, C(O)R<sup>c</sup>, C(S)R<sup>c</sup>, C(O)OR<sup>a</sup>,  
 C(O)NR<sup>a</sup>R<sup>b</sup>, C(S)NR<sup>a</sup>R<sup>b</sup> or S(O)<sub>m</sub>R<sup>c</sup>, S(O)<sub>m</sub>NR<sup>a</sup>R<sup>b</sup>, phenyl, heteroaryl,  
 phenyl-C<sub>1</sub>-C<sub>4</sub>-alkyl and heteroaryl-C<sub>1</sub>-C<sub>4</sub>-alkyl,  
 wherein the rings of the four last mentioned radicals may carry 1, 2, 3,  
 4 or 5 substituents, which, independently from each other are se-  
 lected from halogen, NO<sub>2</sub>, CN, C<sub>1</sub>-C<sub>4</sub>-alkyl, C<sub>1</sub>-C<sub>4</sub>-haloalkyl, C<sub>1</sub>-C<sub>4</sub>-  
 alkoxy and C<sub>1</sub>-C<sub>4</sub>-haloalkoxy;

5

R<sup>e</sup>, R<sup>f</sup> are selected independently from one another from the group consist-  
 ing of hydrogen, C<sub>1</sub>-C<sub>4</sub>-alkyl, C<sub>1</sub>-C<sub>4</sub>-haloalkyl, C<sub>3</sub>-C<sub>6</sub>-cycloalkyl, C<sub>3</sub>-C<sub>6</sub>-  
 alkenyl, C<sub>3</sub>-C<sub>6</sub>-haloalkenyl, C<sub>3</sub>-C<sub>6</sub>-alkynyl, C(O)R<sup>c</sup>, C(O)OR<sup>a</sup>,  
 C(O)NR<sup>a</sup>R<sup>b</sup> and C(S)NR<sup>a</sup>R<sup>b</sup>;

10

n, m are integers selected from 0, 1 or 2;

15

and/or their enantiomers or diastereomers or agriculturally or veterinary accept-  
 able salts, and

with the proviso, that the compound of formula (I) is not representing 4-pyridin-2-  
 ylmethyl-4H-oxazolo[4,5-b]pyridin-2-one or 4-thiophen-2-ylmethyl-4H-  
 oxazolo[4,5-b]pyridin-2-one.

20

2. The compounds of formula (I) according to claim 1, wherein  
 Het is selected from the group consisting of radicals of formulae Het-1 to Het-24:

25

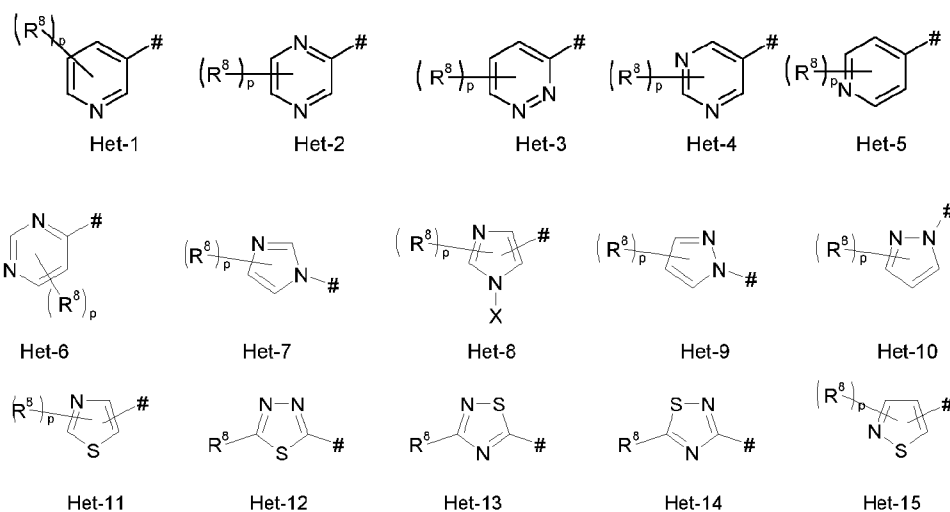

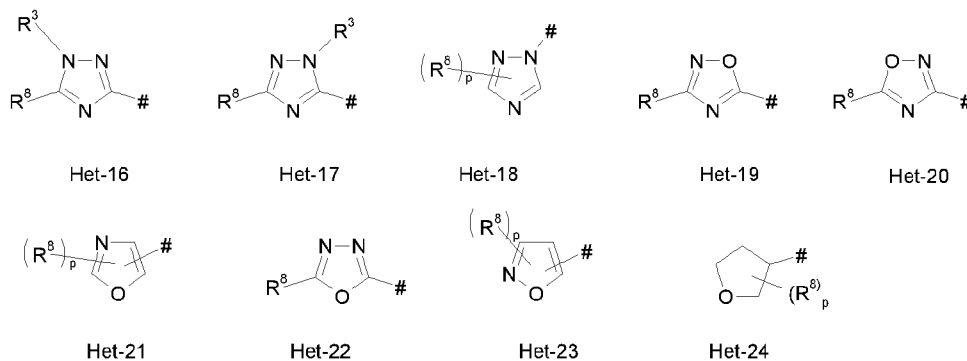

wherein # denotes the bond in formula (I), and

5 p is 0, 1 or 2;

and

R<sup>8</sup> has the meaning as defined in claim 1.

3. The compounds of formula (I) according to claim 2, wherein  
 10 Het is selected from the group consisting of radicals of formulae  
 Het-1, Het-11a and Het-24:

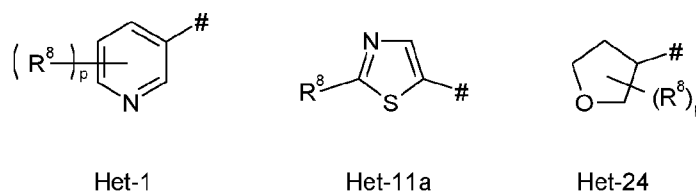

Wherein # denotes the bond in formula (I), and

- 15 R<sup>8</sup> is selected from hydrogen, halogen, C<sub>1</sub>-C<sub>4</sub>-alkoxy or C<sub>1</sub>-C<sub>4</sub>-alkyl,  
 wherein the carbon atoms of the latter two radicals may be partially or  
 fully halogenated;

p is 0, 1 or 2.

- 20 4. The compounds of formula (I) according to claims 1 or 3, wherein  
 Het is Het-1a:

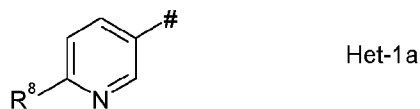

wherein # denotes the bond in formula (I), and  
 R<sup>8</sup> is as defined in claims 1 or 3.

25

5. The compounds of formula (I) according to claims 1 or 3, wherein

Het is Het-11a:

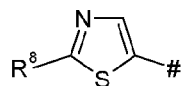

Het-11a

wherein # denotes the bond in formula (I), and  
R<sup>8</sup> is as defined in claims 1 or 3.

5

6. The compounds of formula (I) according to any of the preceding claims, wherein R<sup>1</sup>, R<sup>2</sup> are, independently from one another, selected from the group consisting of hydrogen, halogen, C<sub>1</sub>-C<sub>4</sub>-alkyl, C<sub>1</sub>-C<sub>4</sub>-haloalkyl and C<sub>3</sub>-C<sub>6</sub>-cycloalkyl.

10

7. The compounds of formula (I) according to any of the preceding claims, wherein A is selected from O, S or CH=CH.

15

8. The compounds of formula (I) according to any of the preceding claims, wherein B is N or CR<sup>7</sup>, and wherein R<sup>7</sup> is selected from the group consisting of hydrogen, halogen, C<sub>1</sub>-C<sub>4</sub>-alkyl and C<sub>1</sub>-C<sub>4</sub>-haloalkyl.

20

9. The compounds of formula (I) according to claim 6, wherein B is CR<sup>7</sup>, and wherein R<sup>7</sup> represents a bond to the neighboring atom W<sup>1</sup> such that B and W<sup>1</sup> are connected by a double bond, and wherein W<sup>1</sup> is N or CR<sup>6</sup>, and wherein R<sup>6</sup> is selected from the group consisting of hydrogen, halogen C<sub>1</sub>-C<sub>4</sub>-alkyl and C<sub>1</sub>-C<sub>4</sub>-haloalkyl.

25

10. The compounds of formula (I) according to any of claims 1 to 7, wherein W<sup>1</sup>, W<sup>2</sup>, W<sup>3</sup> and W<sup>4</sup> form together with N and B they are linked to, a saturated or unsaturated 5- or 6-membered heterocycle, wherein the group B-W<sup>1</sup>-W<sup>2</sup>-W<sup>3</sup>-W<sup>4</sup>-N together with the annulated ring forms a bicycle selected from the group of radicals of formulae II-1 to II-25:

30

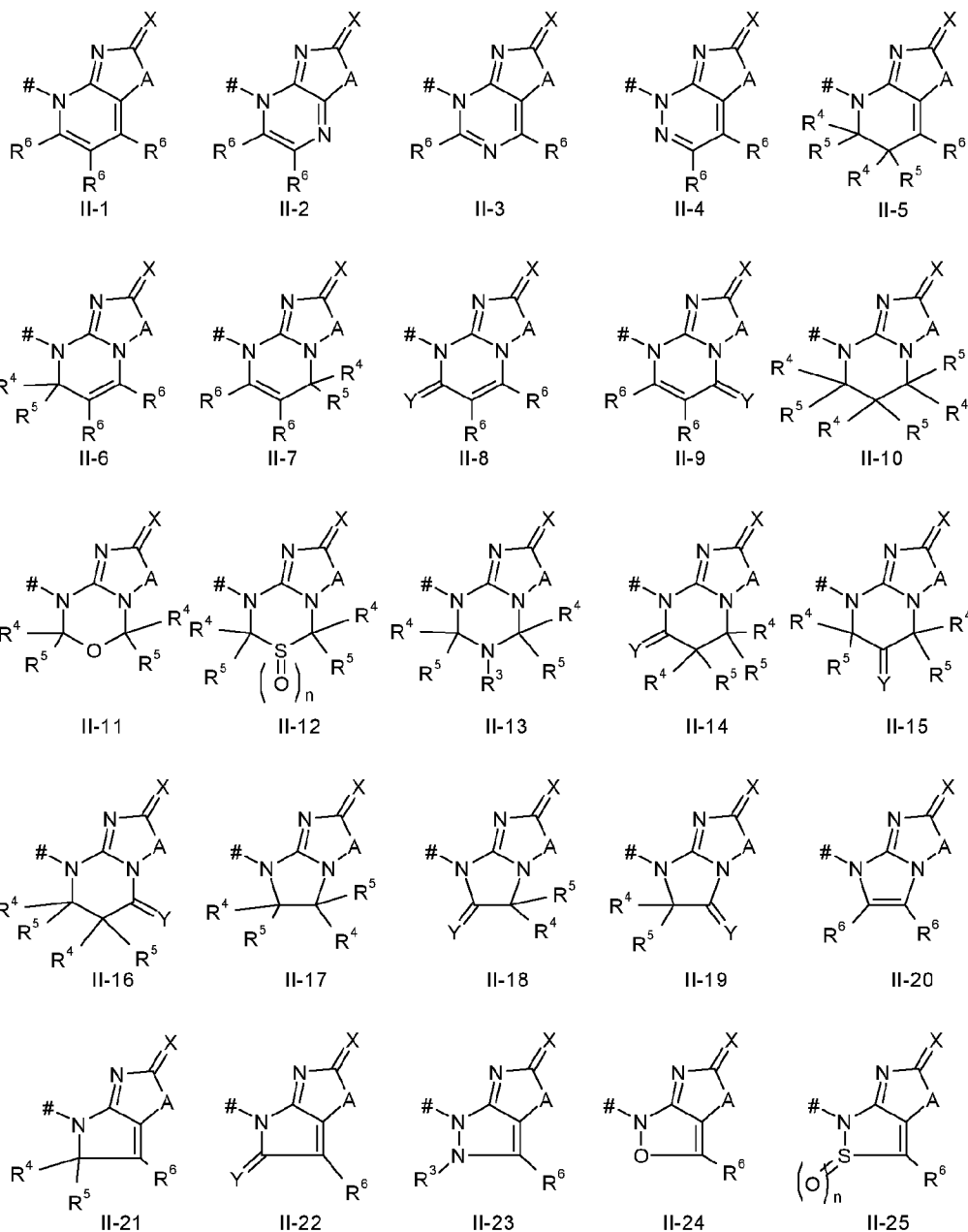

wherein # denotes the attachment to the remainder of the molecule,  
 $R^4$ ,  $R^5$ ,  $R^6$  are selected independently from one another from the group consisting of hydrogen, halogen,  $C_1$ - $C_2$ -alkyl or  $C_1$ - $C_2$ -haloalkyl;

5

11. The compounds of formula (I) according to claim 9, wherein

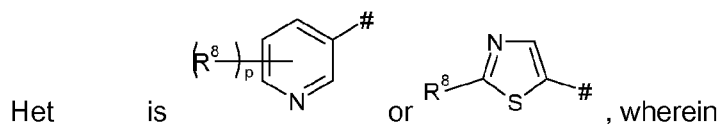

- $R^8$  is selected from the group consisting of halogen, C<sub>1</sub>-C<sub>4</sub>-alkyl and C<sub>1</sub>-C<sub>4</sub>-haloalkyl, and  
 $p$  is 0, 1 or 2;  
 A is O, S or CH=CH;  
 5 X is O or S;  
 and  
 $R^1, R^2$  are independently from one another selected from the group consisting of hydrogen, methyl, ethyl and trifluoromethyl,  
 or  
 10  $R^1$  and  $R^2$  form together with the carbon atom which they are attached to, a cyclopropane ring.

12. The compounds of formula (I) according to claim 10, wherein

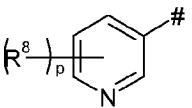
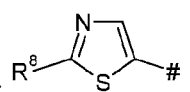
- 15 Het is  or , wherein  
 $R^8$  is selected from the group consisting of halogen and C<sub>1</sub>-C<sub>4</sub>-haloalkyl, and  
 $p$  is 1 or 2;  
 A is O or S;  
 20 X is O or S;  
 and  
 $R^1, R^2$  are both hydrogen;

- 25 13. An agricultural or veterinary composition for combating animal pests comprising at least one compound as defined in any of claims 1 to 12 and at least one inert liquid and/or solid acceptable carrier and optionally, if desired, at least one surfactant.
- 30 14. A method for combating or controlling invertebrate pests of the group of insects, arachnids or nematodes, which method comprises contacting said pest or its food supply, habitat or breeding grounds with a pesticidally effective amount of at least one compound as defined in any one of claims 1 to 12.

15. A method for protecting growing plants from attack or infestation by invertebrate pests of the group of insects, arachnids or nematodes, which method comprises contacting a plant, or soil or water in which the plant is growing, with a pesti-  
5 cidally effective amount of at least one compound as defined in any of claims 1 to 12.
16. A method for the protection of plant proparagation material, especially seeds, from soil insects and of the seedlings' roots and shoots from soil and foliar in-  
10 sects comprising contacting the plant proparagation material before sowing and/or after pregermination with at least one compound as defined in any one of claims 1 to 12.
17. A method for treating animals infested or infected by parasites or preventing ani-  
15 mals of getting infected or infested by parasites or protecting animals against in-  
festation or infection by parasites which comprises orally, topically or parenterally  
administering or applying to the animals a parasitically effective amount of a  
compound as defined in any of claims 1 to 12.
18. The use of a compound as defined in any of claims 1 to 12 for the preparation of  
20 a veterinary composition for treating animals infested or infected by parasites, for  
preventing animals of getting infected or infested by parasites or protecting ani-  
mals against infestation or infection by parasites.

## INTERNATIONAL SEARCH REPORT

International application No  
PCT/EP2012/056253

A. CLASSIFICATION OF SUBJECT MATTER INV. C07D487/02 C07D498/04 C07D513/04 A01N37/32 A01N43/92 A01P7/04 ADD. According to International Patent Classification (IPC) or to both national classification and IPC		
B. FIELDS SEARCHED Minimum documentation searched (classification system followed by classification symbols) C07D A01N A01P Documentation searched other than minimum documentation to the extent that such documents are included in the fields searched Electronic data base consulted during the international search (name of data base and, where practicable, search terms used) EPO-Internal		
C. DOCUMENTS CONSIDERED TO BE RELEVANT		
Category*	Citation of document, with indication, where appropriate, of the relevant passages	Relevant to claim No.
A,P	GEFFKEN, DETLEF; KÖLLNER, MARIA ANNA: "Synthesis of 2-Amino-Imidazo [1,2-b] [1,2,4]Triazine-3,6,7(5H)-Triones", HETEROCYCLIC COMMUNICATIONS, 2 May 2011 (2011-05-02), pages 145-149, XP008151603, compound 5f -----	1,6,8
A	CH 461 489 A (GEIGY AG J R [CH]) 31 August 1968 (1968-08-31) cited in the application the whole document -----	1
Y	WO 2010/005692 A2 (DU PONT [US]; ZHANG WENMING [US]; MCCANN STEPHEN FREDERICK [US]) 14 January 2010 (2010-01-14) cited in the application claim 1 -----	1-18
	-/--	
<input checked="" type="checkbox"/> Further documents are listed in the continuation of Box C. <input checked="" type="checkbox"/> See patent family annex.		
* Special categories of cited documents : "A" document defining the general state of the art which is not considered to be of particular relevance "E" earlier application or patent but published on or after the international filing date "L" document which may throw doubts on priority claim(s) or which is cited to establish the publication date of another citation or other special reason (as specified) "O" document referring to an oral disclosure, use, exhibition or other means "P" document published prior to the international filing date but later than the priority date claimed "T" later document published after the international filing date or priority date and not in conflict with the application but cited to understand the principle or theory underlying the invention "X" document of particular relevance; the claimed invention cannot be considered novel or cannot be considered to involve an inventive step when the document is taken alone "Y" document of particular relevance; the claimed invention cannot be considered to involve an inventive step when the document is combined with one or more other such documents, such combination being obvious to a person skilled in the art "&" document member of the same patent family		
Date of the actual completion of the international search	Date of mailing of the international search report	
21 May 2012	29/05/2012	
Name and mailing address of the ISA/ European Patent Office, P.B. 5818 Patentlaan 2 NL - 2280 HV Rijswijk Tel. (+31-70) 340-2040, Fax: (+31-70) 340-3016	Authorized officer  Skulj, Primoz	

## INTERNATIONAL SEARCH REPORT

International application No  
PCT/EP2012/056253

C(Continuation). DOCUMENTS CONSIDERED TO BE RELEVANT		
Category*	Citation of document, with indication, where appropriate, of the relevant passages	Relevant to claim No.
Y	<p>PETER JESCHKE ET AL: "Neonicotinoids-from zero to hero in insecticide chemistry", PEST MANAGEMENT SCIENCE, vol. 64, no. 11, 1 November 2008 (2008-11-01), pages 1084-1098, XP55008551, ISSN: 1526-498X, DOI: 10.1002/ps.1631 paragraphs [03.2], [04.2]; table 1</p> <p>-----</p>	1-18
Y	<p>ATSUSHI OKAZAWA: "Three-dimensional quantitative structure- activity relationship analysis of acyclic and cyclic chloronicotinyl insecticides", PEST MANAGEMENT SCIENCE, 1 January 2000 (2000-01-01), pages 509-515, XP55026184, figure 2</p> <p>-----</p>	1-18

# INTERNATIONAL SEARCH REPORT

Information on patent family members

International application No

PCT/EP2012/056253

Patent document cited in search report	Publication date	Patent family member(s)	Publication date
CH 461489	A	31-08-1968	NONE
-----			
WO 2010005692	A2	14-01-2010	NONE
-----			