

No. 623,992.

Patented May 2, 1899.

W. E. CURTIS.
POWER TRANSMITTING MECHANISM.

(Application filed Mar. 24, 1899.)

(No Model.)

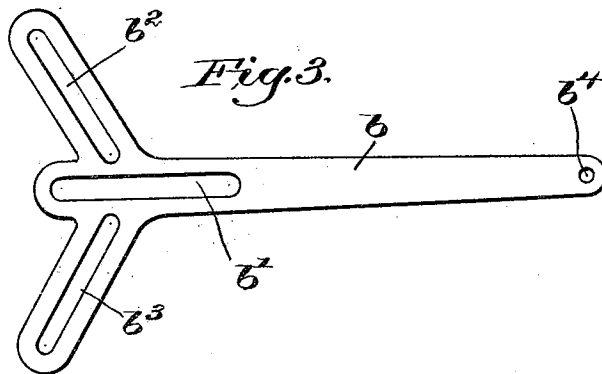
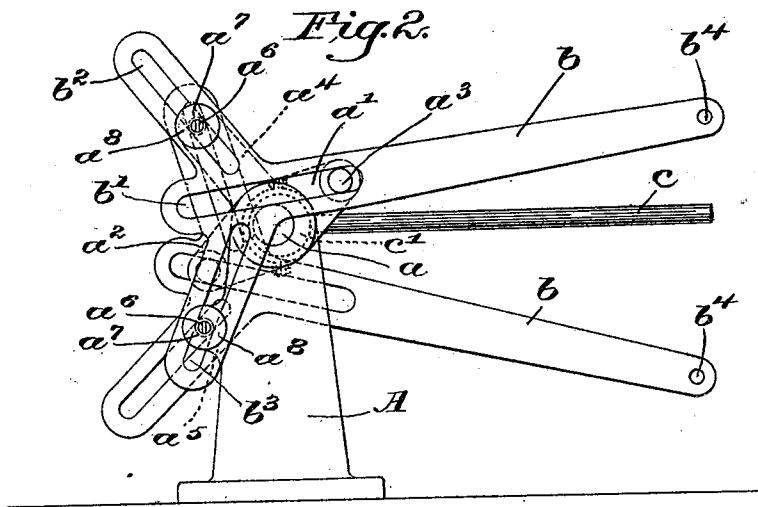
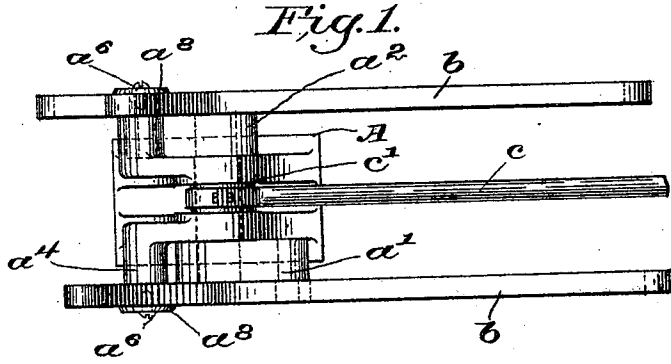

Witnesses.
Thomas J. Drummond
James M. Higubatt.

Inventor.
William E. Curtis.
by Crosby & Gregory
Attys.

UNITED STATES PATENT OFFICE.

WILLIAM E. CURTIS, OF TAUNTON, MASSACHUSETTS.

POWER-TRANSMITTING MECHANISM.

SPECIFICATION forming part of Letters Patent No. 623,992, dated May 2, 1899.

Application filed March 24, 1899. Serial No. 710,327. (No model.)

To all whom it may concern:

Be it known that I, WILLIAM E. CURTIS, of Taunton, county of Bristol, State of Massachusetts, have invented an Improvement in
5 Power-Transmission Mechanism, of which the following description, in connection with the accompanying drawings, is a specification, like letters on the drawings representing like parts.

10 My invention is an apparatus for transmitting power with various advantages of movement and conservation of energy and other advantages, all as will be more particularly explained hereinafter.

15 My invention is more particularly adapted for use in comparatively small machines, such as bicycles, pumps, small engines, &c.; and it consists, in general terms, in providing a power-receiving lever for engaging a crank-pin, said lever having a longitudinal slot in
20 which the pin may play and being provided with obliquely-divergent guide-slots adjacent thereto for permitting the fulcrum-point of the lever to change according to the position
25 of the lever.

The details of construction and manner of operation of my invention will be pointed out in the following description, reference being had to the accompanying drawings, in which
30 I have shown one embodiment of my invention.

In the drawings, Figure 1 is a top plan view of sufficient details of construction to enable my invention to be understood. Fig.
35 2 shows the same in side elevation. Fig. 3 is a view in side elevation of one of the power-receiving levers.

For convenience of illustration and description I have herein shown my mechanism mounted on a stand or pedestal A, although
40 it will be understood that in practice the mechanism will be mounted in any suitable situation desired, according to the machine with which it is to be used. Journalled in the upper end of this standard is a transverse crank-shaft a , having at its ends oppositely-extending cranks a^1 a^2 , each containing
45 crank-pins a^3 .

The standard A has at its rear side and opposite edges upper and lower brackets a^4 a^5 ,
50 each provided with studs a^6 , on which are

mounted friction-rolls a^7 (shown in dotted lines) and retaining-washers a^8 . Mounted on the opposite crank-pins a^3 and the friction-rolls a^7 are similar power receiving or transmitting levers b , one of these being shown in
55 detail in Fig. 3, where it will be seen that it has a longitudinal slot or way b^1 and upper and lower obliquely-divergent guide-slots b^2 b^3 . The slot b^1 receives the crank-pin a^3 , the
60 slot b^2 receiving the stud and friction-roll of the bracket a^4 , and the slot b^3 receiving the stud and friction-roll of the bracket a^5 . The converging ends of the slots b^2 b^3 , adjacent the slot b^1 , project forward, so that as the
65 lever b is moved up and down, being connected at b^4 with the power, the crank a^1 or a^2 , as the case may be, is correspondingly moved, and its pin a^3 is caused to reciprocate back
70 and forth in the slot as the shaft a rotates, and meanwhile the slots b^2 b^3 guide the lever in a bodily-swinging movement, substantially as shown in Fig. 2, so that instead of the lever b swinging as it would if pivoted on a stationary pivot at one end it constantly
75 shifts its fulcrum or pivotal point up and down.

The power may be transmitted from the mechanism described in any suitable means, a connecting-rod c being herein shown, for
80 convenience of illustration, mounted on an eccentric c^1 on the shaft a , although I do not intend to be limited in any way to these details.

The operation of my invention has already
85 been explained; but it will perhaps be better understood if we suppose that it is used for operating a bicycle, in which case the levers b would be the pedal-levers and would carry pedals at their ends at b^4 for the feet of the
90 operator to rest upon, and the crank-shaft a would then be connected by a sprocket-wheel and chain or other means to the rear drive-wheel of the bicycle. As the rider then depressed one pedal—as, for instance, from the
95 position shown at the near side, Fig. 2, to an opposite or lowermost position—the lever b would cause the near crank-pin a^3 to travel down to perform the lower part of its revolution, and in doing so it would slide rearwardly
100 in the slot a^1 , giving increasing leverage as the lever b descended, and then the same op-

eration would take place in the opposite lever while the near crank-pin a^3 was completing its revolution ready to descend again.

The slots $b^2 b^3$ besides operating as already described and giving smooth easy movement also make it possible to revolve the cranks $a' a^2$ with a small amplitude of swinging movement of the levers b .

It will be understood that while I prefer that the guides $b^2 b^3$ should be in the form of slots in the lever b I do not limit myself to this particular arrangement, inasmuch as my object is merely to get the bodily-oblique movement, as described.

Having described my invention, what I claim, and desire to secure by Letters Patent, is—

1. A power-transmitting device comprising a shaft to be rotated, a crank and crank-pin mounted thereon, and a lever having a longitudinal slot receiving said crank-pin, and

divergent guides cooperating with studs working in said guides, for permitting the lever to have a limited bodily movement with the crank-pin, substantially as described. 25

2. A power-transmitting device comprising a shaft to be rotated, a crank and crank-pin mounted at each end thereof, and a lever for each crank-pin, having a longitudinal slot receiving said crank-pin, and divergent guides cooperating with studs working in said guides, for permitting the lever to have a limited bodily movement with the crank-pin, substantially as described. 30

In testimony whereof I have signed my name to this specification in the presence of two subscribing witnesses. 35

WILLIAM E. CURTIS.

Witnesses:

GEO. H. MAXWELL,

FREDERICK L. EMERY.