

Aug. 26, 1969

A. PODESTA ET AL

3,463,349

TIGHTLY SEALED CAN WITH REMOVABLE LID AND METHOD

Filed Dec. 14, 1967

2 Sheets-Sheet 1

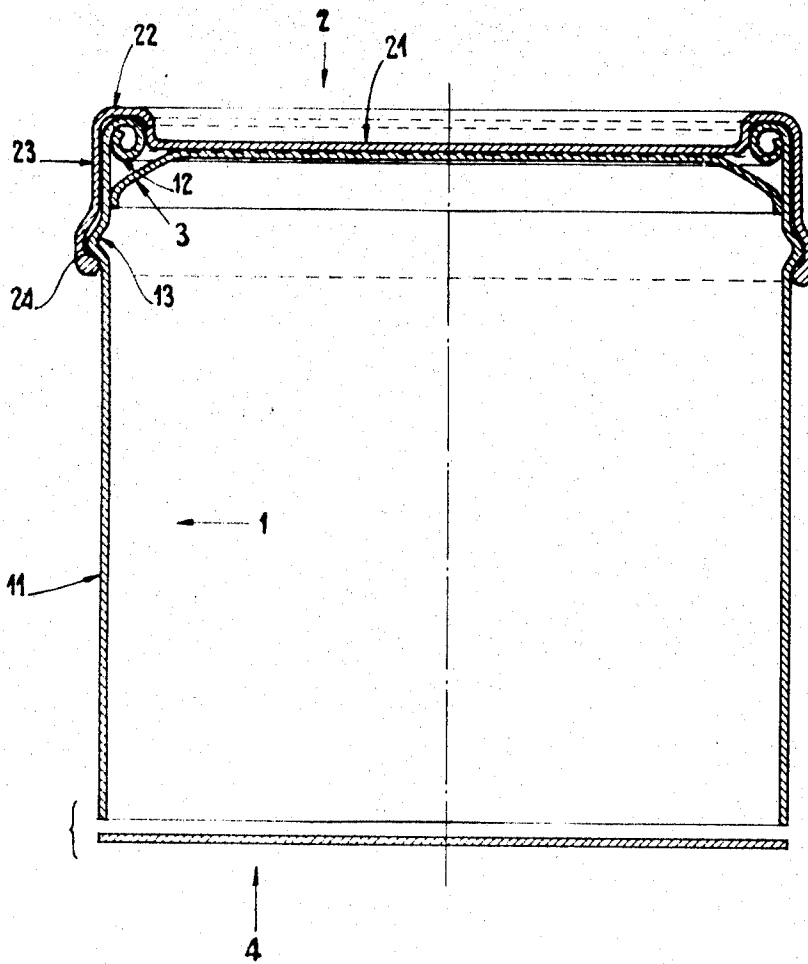

FIG. 1

INVENTORS
Armando Podesta
BY Carlo Vignati
McDougal, Hersh, Scott
and Paddell Attys

Aug. 26, 1969

A. PODESTA ET AL

3,463,349

TIGHTLY SEALED CAN WITH REMOVABLE LID AND METHOD

Filed Dec. 14, 1967

2 Sheets-Sheet 2

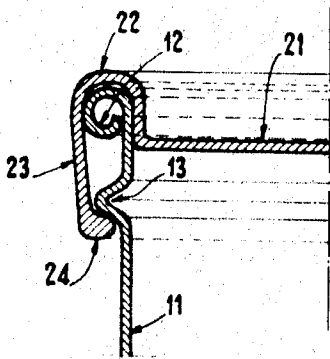

FIG. 2

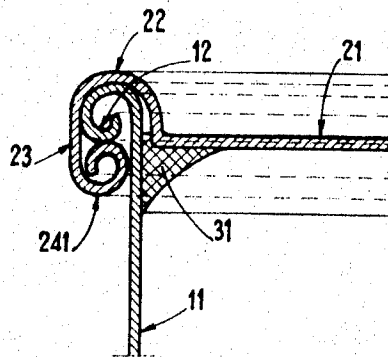

FIG. 3

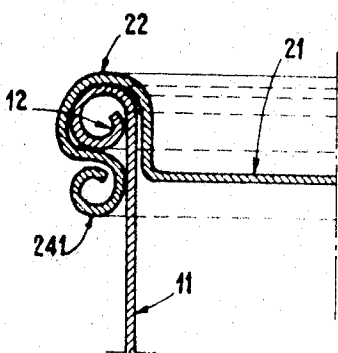

FIG. 4

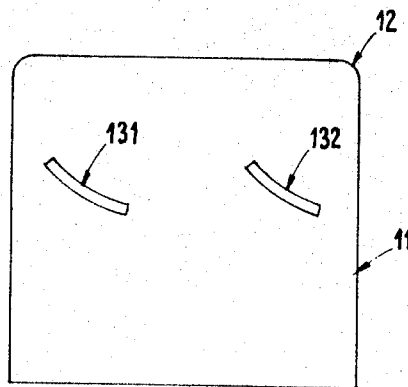

FIG. 5

1

2

3,463,349

TIGHTLY SEALED CAN WITH REMOVABLE LID AND METHOD

Armando Podesta, 4 via Petrarca, and Carlo Vignati, 3 Piazza Sicilia, both of Milan, Italy

Filed Dec. 14, 1967, Ser. No. 690,499

Claims priority, application France, Dec. 19, 1966, 87,904

Int. Cl. B65d 43/04, 43/10

U.S. Cl. 220—60

12 Claims

ABSTRACT OF THE DISCLOSURE

The manufacture of a tightly sealed can with a removable lid in which the can body is of tubular shape having a coiled upper end portion and a first locking portion in the form of outward projections in spaced relation from the coiled end portion, a lid having a body portion dimensioned to correspond with the cross-section of the can body and a depending skirt having an inturned second locking portion in position resiliently to engage the first locking portion when the lid is in position of use on the can body, a sealing means at the juncture between the underside of the can lid and the inside of the can body to effect a sealing relationship therebetween and a bottom on the lower end of the can body and in which the first locking portion and the coiled upper end portion on the can body constitute the same element in the can body.

This invention relates to a tightly sealed can having a detachable lid and to a method for the manufacture of same.

The sealed can of this invention is adapted for use as a food container, including solid foods such as preserves, vegetables, meats and the like, and liquids such as beverages. It is known to fabricate such sealed cans having, as a starting point, a can with an integral inserted bottom which, after being filled with the desired content material, is closed with a detachable lid after it has been put in place with a tightly sealed joint. This construction and operation requires high precision in the formation of the elements of the can and lid with the result that such containers are relatively high in cost.

It is an object of this invention to produce and to provide a method for producing a tightly sealed can having a detachable lid which is relatively easy and inexpensive to produce, which can be formed of relatively low cost and readily available materials and which is simple in construction and operation.

These and other objects and advantages of this invention will hereinafter appear and for purposes of illustration, but not of limitation, embodiments of the invention are shown in the accompanying drawings in which—

FIG. 1 is a sectional elevational view of a can with a detachable lid fabricated in accordance with the practice of this invention;

FIG. 2 is a sectional elevational view showing a modified in the can and lid construction;

FIG. 3 is a sectional elevational view similar to that of FIG. 2 showing a further modification;

FIG. 4 is a sectional elevational view similar to that of FIGS. 2 and 3 showing a still further modification; and

FIG. 5 is a side plan view showing a modification in construction of an upper portion of the can body.

In accordance with the practice of this invention, there is first provided a can body, in the form of a tubular member, which defines the side walls of the can and which can be fabricated by various known methods per

se. The side wall is formed at its upper end with a coiled or looped end portion which can function alone or preferably in combination with a first locking element formed in a spaced portion of the side wall in the form of projections.

The lid comprises a relatively flat horizontally disposed central body portion having a depending vertically disposed skirt shaped to provide a second locking element which cooperates with the first releasably to lock the can lid on the can body.

A sealing means is provided for sealing engagement between the underside of the body portion of the lid and the interior of the can body and particularly at the juncture between the lid and the side wall of the can body for sealing the end portion with the detachable lid in mounted relation.

The can is then filled with content material and the bottom is secured onto the lower end of the side walls of the tubular member by any of the well-known means, such as gluing, welding, interjoining and sealing, and the like.

In a preferred modification the joint for tightly sealing consists of a foil of fluid and vapor impervious material, such as a metal foil, which is bonded in sealing relationship to the interior surface of the side wall of the tubular member and the bottom side of the lid. In another modification, the tightly sealed joint is effected with a hardenable material, such as a plastic, which is poured to form a juncture between the can side wall and the underside of the lid and then hardened in place.

Referring now to the drawings, the can comprises a can body 1 having side wall 11 joined in sealing relationship at its lateral edges to provide a tubular member which may be cylindrical, oblong, square, rectangular or of other polygonal shape. The upper end portion of the side wall is coiled inwardly in FIG. 1 or outwardly in FIGS. 2, 3 and 4 to provide a coil 12 extending continuously about the upper edge. Spaced downwardly a short distance from the upper edge is one of the elements forming a part of the locking device for the lid in the form of an offset 13 which projects outwardly from the side wall of the can.

The can lid 2 is formed with a central body portion 21 dimensioned to correspond to the area between the side walls of the can with a skirt 23 depending downwardly substantially perpendicularly from the outer edge of the body portion 21 with means in the lower end portion of the skirt adapted operatively to engage the element 13 in the side wall 11 releasably to lock the lid onto the can body. In the modification shown in FIGS. 1 and 2, such can lid locking means comprises a lip 24 extending inwardly from the lower end portion of the skirt 23 to snap over the projection 13 from the side wall of the can body resiliently to engage the underside thereof when in position of use.

The tight seal 3 shown in FIG. 1 comprises a thin strip of a fluid and vapor impervious material, such as aluminum or other metal foil, dimensioned to have an area greater than the area between the side walls of the can with a flat central body portion which is adhesively secured in sealing relation to the bottom side of the can lid 24 while the outer edges are turned downwardly into engagement with the adjacent side wall of the can body for attachment thereto in sealing relation, as by an adhesive or the like.

The can is completed with a bottom 4 secured to the lower edge portion of the can side wall 11 in a conventional manner for metal can construction.

In assembly, the lid 2 is positioned on the upper end of the can body by pressing the lid endwise onto the end of the can body until the locking device 13-24 becomes

effective as the lip 24 clears the protuberance 13 resiliently to engage the underside thereof. The sealing joint 3 is formed by application of the sealing strip or by filling the juncture with hardenable sealing material or plastic 31, as shown in FIG. 3.

The can with lid attached is then inverted for filling with desired content material through the open bottom and then the bottom 4 is secured in place to complete the filled can.

It is advantageous to form the lid with the outer end portion 22 raised to provide a recessed portion on the underside adapted to receive the edge coil 12 in fitting relationship therein as an additional locking and sealing means. The central body portion 21 of the lid can be flat, as illustrated, or of other configurations such as convex, grooved and the like, and the relatively flat surface can serve as a support for printed matter, labels or the like.

As previously described, the upper edge coil 12 can extend inwardly, as illustrated in FIG. 1, or outwardly of the can body 11, as illustrated in FIGS. 2, 3 and 4. In the latter instances, the locking element 13 in the can body can have its function included within the upper edge coil 12, in which event the lip 24 is provided in the form of a coil 241 spaced downwardly from the upper edge of the skirt by an amount to engage the underside of the upper edge coil 12 when the lid is placed in position of use on the can body. The locking coil 241 on the edge of the skirt can turn inwardly from the lower edge portion of the skirt in spaced relationship from the upper edge by an amount corresponding to the upper edge coil 12 plus the skirt coil 241, as shown in FIG. 3, or it can be turned outwardly from an inwardly turned end portion of the skirt spaced from the upper edge corresponding to the height of the upper edge coil 12 so that the inwardly turned portion will underlie the upper edge coil 12, as shown in FIG. 4.

The locking device for the can lid can consist of the flange portion 13 arranged to be parallel with the upper edge coil 12 and with a corresponding arrangement of the lip portion 24 on the can lid. The locking device can also be formed of at least two flanged portions in the form of downwardly curved rails formed at the side walls 11 for camming engagement with the inward projections on corresponding portions of the skirt 23 of the can lid.

The foil used in making up the joint 3 should be an impermeable material which is not reactive with the materials making up the side wall or the lid 21 of the can and which has no effect and which is in no way reactive with the content material with which the can is filled. It is not necessary that the foil extend across the bottom wall of the lid since it will be sufficient if the foil extends continuously from the side wall of the can body to an adjacent portion of the underside of the can lid for engagement therewith. Instead of making use of a foil which is glued or otherwise adhesively secured in sealing relationship to the underside of the can lid and to the side wall of the can body, the sealing joint can be formed by pouring a hardenable compound 31 into the zone formed at the juncture of the side wall 11 with the underside of the body portion 21 of the can lid. This same procedure may be followed in the modification shown in FIGS. 1, 2 and 4.

The bottom 4 is of conventional construction and is secured at the lower edge portion of the side wall to complete the can by well known means for can construction, as by intertwining, soldering, gluing, welding, sealing and the like. The side wall is formed in the conventional manner by drawing or by rolling strip or sheet stock with the lateral edges welded, soldered, brazed or glued for joinder in sealing relation. The lid can be molded or stamped of metal sheet stock or the like.

The elements of the can may be selected of various materials, such as of aluminum, tin plate, plastics or the

like, and the elements 1, 2 and 4 can be fabricated of the same materials or of different materials. Sealing joint 3 can be a plastic, as in FIG. 3, or it can be formed of a metal foil.

Removal of the can lid can be accomplished merely by application of force onto the second element 24 or 241 of the lid which has sufficient elasticity for outward displacement to clear the abutments 13 or the upper edge coil 12, as the case may be, to enable the cover to be lifted from the can body after breaking the seal 3. With the curved rails 131, 132 (FIG. 5), the seal can be broken and the lid cleared for removal merely by turning the lid relative to the can body to unscrew the lid. The elements permit replacement of the lid for reengagement in position of use on the can body but once broken, the tight sealing relationship cannot be reestablished.

We claim:

1. A tightly sealed can having a removable lid comprising a can body in the form of a tubular member having a coiled upper end portion and an outwardly protruding first locking portion spaced a short distance below the coiled upper end portion, a can lid having a central body portion dimensioned to span the can body and a skirt portion depending from the outer edge of the central body portion for disposition about the upper end portion of the can body and having an inturned portion in position resiliently to engage said first locking portion when the can lid is in position of use on the can body, a sealing joint between the adjacent portions of the underside of the can lid and the inner wall of the can body to effect a sealing relationship therebetween, and a bottom in sealing engagement across the lower end of the can body.

2. A can as claimed in claim 1 in which the sealing joint comprises a foil of an impermeable material bonded at one end in sealing relationship to the underside of the can lid and at the other end to the adjacent inner side wall of the can body.

3. A can as claimed in claim 1 in which the sealing joint comprises a hardenable material in the juncture between the side wall of the can body and the can lid.

4. A can as claimed in claim 1 in which the outwardly protruding first locking means and the coiled upper end portion comprise the same element.

5. A can as claimed in claim 4 in which the inturned portion comprises a coiled lower end portion on the skirt spaced from the upper edge by an amount resiliently to engage the underside of the upper coiled portion of the can body.

6. A can as claimed in claim 5 in which the coiled lower end portion comprises an inturned coiled portion at the lower edge of the skirt.

7. A can as claimed in claim 5 in which the coiled lower end portion comprises an outturned coiled portion at the lower edge of the skirt.

8. A can as claimed in claim 1 in which the body portion of the lid has a raised portion about the outer edge to provide a recessed portion dimensioned to receive the upper coiled end portion of the can body in fitting engagement therewith.

9. A can as claimed in claim 1 in which the outwardly projecting first locking means on the can body comprises spaced curved rails and in which the skirt on the can lid is formed with inward projections positioned to engage the curved rails to enable the lid to be screwed onto and off of the can body.

10. A process for the manufacture of a tightly sealed can having a removable lid as claimed in claim 1 comprising providing a can body in the form of a tubular member having an upper coiled end portion and a first locking means in the form of an outward protuberance spaced a short distance from the upper coiled end portion, providing a can lid having a central body portion dimensioned to correspond to the cross-sectional area of the tubular member and a skirt depending downwardly from

5

the outer edge of the body portion with an inturned portion on the skirt positioned resiliently to engage the underside of the protuberance of the first locking means, pressing the can lid downwardly onto the coiled upper end portion of the can body until the inturned end portion clears the protuberance resiliently to lock the can lid onto the can body, then attaching a sealing means at the juncture between the underside of the can lid and the inner side of the can body to effect a sealing relationship between the can lid and can body, inverting the can and filling the can through the bottom side with the desired content material, and then fastening the bottom in sealing relation to the lower end of the can body.

11. A process as claimed in claim 10 in which the sealing means comprises a foil of an impermeable material and in which attachment is effected by bonding the

6

inner portion of the foil to the underside of the body portion of the can lid and the outer portion of the foil to the adjacent inner side wall of the can body.

12. A process as claimed in claim 10 in which the sealing means comprises a hardenable bonding material and in which attachment is effected by pouring the material into the juncture between the body portion of the can lid and the can body and hardening the material.

References Cited

UNITED STATES PATENTS

2,251,987	8/1941	Conway	-----	220—27
2,267,422	12/1941	Rakowitzky	-----	220—68
3,333,728	8/1967	Burdick	-----	220—60

JAMES B. MARBERT, Primary Examiner