

(No Model.)

C. A. ANDERSON.  
BRAKE LEVER.

No. 521,252.

Patented June 12, 1894.

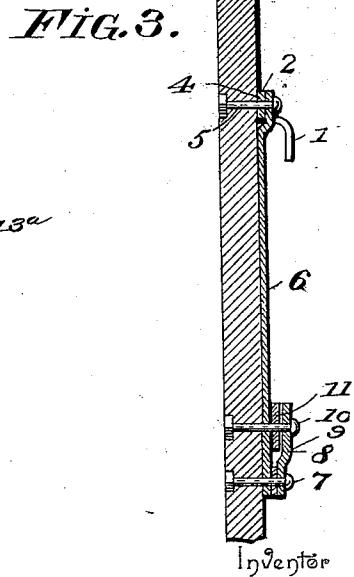
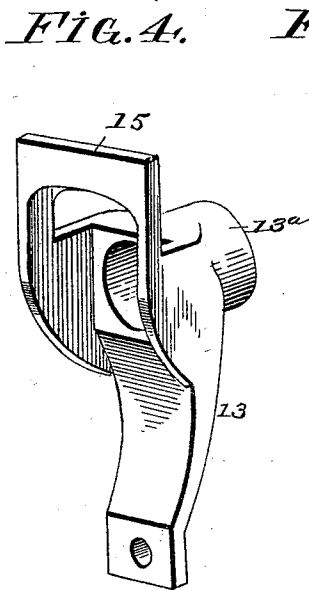
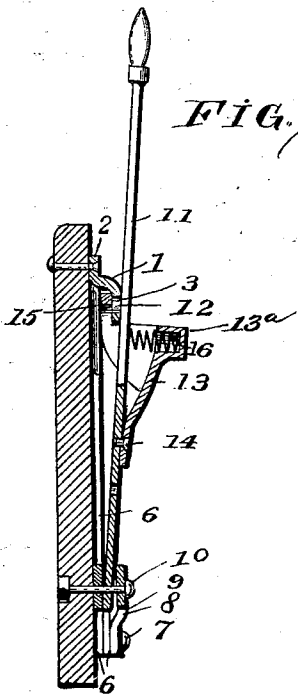
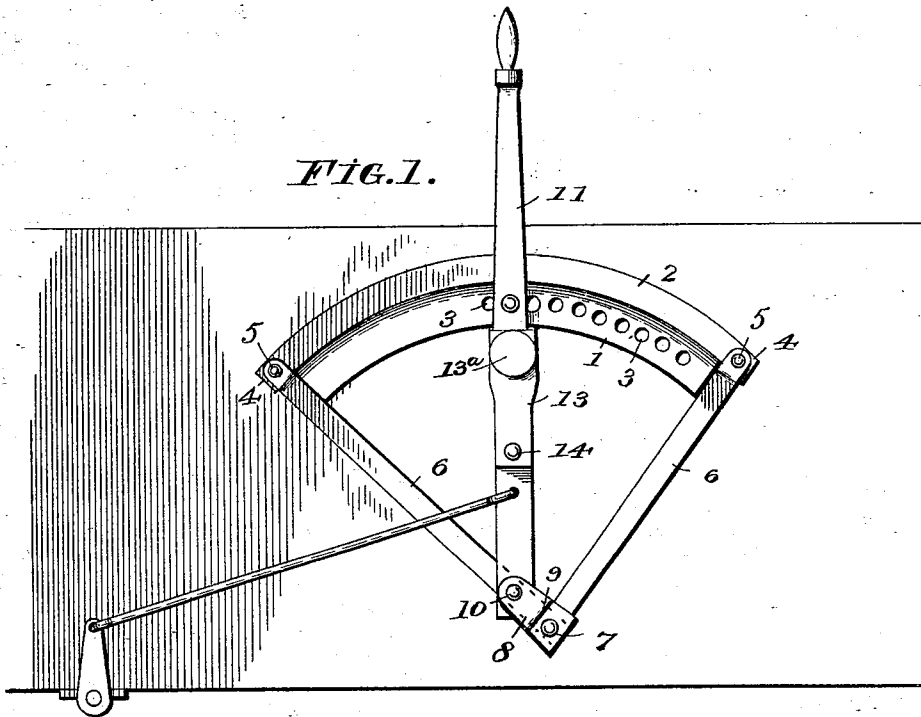

Carl A. Anderson,

Witnesses

Julius Ulke, Jr.  
W. S. Duval.

By his Attorneys.

C. A. Snow & Co.

# UNITED STATES PATENT OFFICE,

CARL A. ANDERSON, OF LYNN CENTER, ILLINOIS.

## BRAKE-LEVER.

SPECIFICATION forming part of Letters Patent No. 521,252, dated June 12, 1894.

Application filed December 8, 1893. Serial No. 493,183. (No model.)

### *To all whom it may concern:*

Be it known that I, CARL A. ANDERSON, a citizen of the United States, residing at Lynn Center, in the county of Henry and State of Illinois, have invented a new and useful Brake-Lever, of which the following is a specification.

My invention relates to improvements in brakes of that class employed on wagons, and has special reference to improvements concerning the brake-lever for throwing on or off the brakes, and the locking-mechanism for the same, whereby said brakes may be locked "on."

The objects of my invention are to provide a very light, simply constructed, strong and durable mechanism of this class adapted to be readily applied to the wagon-body without danger of splitting the same by reason of undue weight; which may be readily manufactured and compactly packed for shipment; which is so constructed as to necessitate in the operation thereof the manipulation of but one lever; and which will automatically lock at any point of the locking-plate.

Other objects and advantages of the invention will appear in the following description, and the novel features thereof will be particularly pointed out in the claims.

Referring to the drawings:—Figure 1 is a front elevation of a brake embodying my invention. Fig. 2 is a vertical sectional view through the brake-lever and the locking-plate. Fig. 3 is a detail of the hollow keeper. Fig. 4 is a longitudinal sectional view through one of the braces and the triangular fulcrum-plate for the lever.

Like numerals of reference indicate like parts in all the figures of the drawings.

In the practice of my invention I construct an arc or segmental shaped locking-plate of light sheet-steel, the same consisting of the outer perforated securing plate 1 and the inner outwardly and downwardly disposed locking-flange 2 formed integral with the plate 1 and provided for the major portion of the length of its downwardly disposed part with a series of perforations 3. The securing-plate 1 extends beyond the locking flange 2, forming ears or extensions 4, and the same are perforated, as shown, for the reception of bolts 5 by which the locking-plate is secured

in position against a wagon-body. By means of the bolts 5 above mentioned I also secure to the locking-plate and wagon-body the upper ends of a pair of brace-straps 6 whose lower ends converge and meet at a point below the locking-plate and are bolted to each other and to the wagon-body by a bolt 7. A triangular keeper-plate 8 is perforated and secured by the bolt 7 at the point of meeting of the two braces 6, and said plate extends over one of said braces and is offset therefrom, as at 9, perforated, and has passed therethrough a fulcrum-bolt 10, which also passes through the brace which is overlapped thereby.

Fulcrumed on the bolt 10 is the resilient hand-lever 11, which is reduced from this point over and above the locking-flange of the locking-plate, and is provided upon its inner side or face opposite the perforations in said locking-flange with a locking-lug 12. This locking-lug travels in a path corresponding with the perforations, and hence may be engaged with any of the same opposite which it may happen to be located.

A tubular keeper 13 is slipped over the lever 11 and bolted thereto at 14 below the locking-plate. This keeper is provided at its upper end upon its inner side with an extension flange or lug 15, and the same takes under the locking-flange 2, so that the lever is maintained in proper relative position with the locking-plate, and at its outer side is provided with a tubular offset or pocket 13'.

A coiled spring 16 is seated in the pocket of the tubular keeper and bears against the outer face of the lever, said spring being of the expansive pattern has a constant tendency to force the lever inward, so that its lug is maintained, when not otherwise influenced, in engagement with the opening or perforation 3 of the locking-plate.

The upper end of the lever 11, it will be understood, is shaped to adapt it to the hand, and in order to operate said lever and either apply or release the brakes, it is simply necessary to press the lever outward against the tension of the coiled-spring, whereby a disengagement between the lug and the perforation takes place. The lever may now be swung like any ordinary lever toward either end of the locking-plate, and as soon as re-

leased will automatically re-engage with a proper perforation, whereby the brakes are held locked "on."

It will be observed that in operation the manipulation of but one lever is required, which reduces the labor and time necessarily consumed to a minimum.

The device being constructed wholly of sheet metal is light, strong, and readily manufactured, and being formed in parts that are separable, may be conveniently packed for shipment and easily set up or taken down when so desired. Any looseness of the parts caused by use will be compensated for by the coiled spring contained within the tubular keeper, and it will be obvious that no rattling can take place by reason thereof.

Having described my invention, what I claim is—

1. In a brake-mechanism, the combination with the opposite braces bolted together at their lower ends and diverging toward their upper ends, and the intermediate curved sheet-metal locking-plate perforated to form a securing-flange and having its inner edge outwardly and downwardly disposed and perforated to form a locking-flange of a brake-lever fulcrumed adjacent to the lower ends of the braces and concentric with the locking-plate, a lug on the inner side of the brake-lever for engaging the perforations of the locking flange, a tubular keeper mounted on the outer face of the brake-lever and having an opening to receive the brake-lever and provided with an upward extending flange at the inner side of the brake-lever to engage under the perforated locking-flange of the locking-plate, and a spring interposed between the brake-lever and the outer side of the tubular keeper, substantially as specified.

2. In a brake-mechanism, the combination with the opposite converging straps bolted to-

gether at their lower ends, the upper curved locking-plate having its lower side outwardly and downwardly extended and perforated to form a locking-flange, the triangular plate 7 at the lower ends of the braces offset at its upper end, and having a fulcrum-bolt passed therethrough, bolts through the upper ends of the braces and the upper ends of the locking-plate, the yielding brake-lever pivoted at its lower end on the fulcrum-bolt and extending over and beyond the perforated locking-flange, the lug on the inner side of the brake-lever, the tubular keeper arranged on the outer face of the brake-lever and having an opening to receive the same and provided with a flange arranged at the inner side of the lever and extended under the locking-flange, said keeper being provided with a tubular pocket and the coiled-spring arranged in the tubular pocket and interposed between the outer wall of the keeper and the face of the brake-lever, substantially as specified.

3. In a brake-mechanism, the combination with the curved locking-flange having locking perforations, of a concentrically pivoted lever having an inner locking-lug, a tubular keeper arranged on the outer face of the lever and provided with an opening receiving the latter and having its upper end arranged at the inner face of the lever and engaging the flange of the locking-plate over the end of the locking-lug, and a coiled-spring interposed between the outer wall of the tubular keeper and the lever, substantially as specified.

In testimony that I claim the foregoing as my own I have hereto affixed my signature in the presence of two witnesses.

CARL A. ANDERSON.

Witnesses:

FRANK L. BRODD,  
C. R. DALRYMPLE.