



- (51) International Patent Classification:  
F41C 23/06 (2006.01)
- (21) International Application Number:  
PCT/US2016/037119
- (22) International Filing Date:  
12 June 2016 (12.06.2016)
- (25) Filing Language: English
- (26) Publication Language: English
- (30) Priority Data:  
14/738,607 12 June 2015 (12.06.2015) US  
14/922,152 24 October 2015 (24.10.2015) US
- (72) Inventor; and
- (71) Applicant : HUANG, George [US/US]; 526 Via Ripagrande Avenue, Henderson, NV 89011 (US).
- (74) Agent: SHADDOCK, Peter, A., II; Shaddock Law Group, PC, 1209 Independence Blvd., Suite 106, Virginia Beach, VA 23455 (US).
- (81) Designated States (unless otherwise indicated, for every kind of national protection available): AE, AG, AL, AM, AO, AT, AU, AZ, BA, BB, BG, BH, BN, BR, BW, BY, BZ, CA, CH, CL, CN, CO, CR, CU, CZ, DE, DK, DM,

DO, DZ, EC, EE, EG, ES, FI, GB, GD, GE, GH, GM, GT, HN, HR, HU, ID, IL, IN, IR, IS, JP, KE, KG, KN, KP, KR, KZ, LA, LC, LK, LR, LS, LU, LY, MA, MD, ME, MG, MK, MN, MW, MX, MY, MZ, NA, NG, NI, NO, NZ, OM, PA, PE, PG, PH, PL, PT, QA, RO, RS, RU, RW, SA, SC, SD, SE, SG, SK, SL, SM, ST, SV, SY, TH, TJ, TM, TN, TR, TT, TZ, UA, UG, US, UZ, VC, VN, ZA, ZM, ZW.

(84) Designated States (unless otherwise indicated, for every kind of regional protection available): ARIPO (BW, GH, GM, KE, LR, LS, MW, MZ, NA, RW, SD, SL, ST, SZ, TZ, UG, ZM, ZW), Eurasian (AM, AZ, BY, KG, KZ, RU, TJ, TM), European (AL, AT, BE, BG, CH, CY, CZ, DE, DK, EE, ES, FI, FR, GB, GR, HR, HU, IE, IS, IT, LT, LU, LV, MC, MK, MT, NL, NO, PL, PT, RO, RS, SE, SI, SK, SM, TR), OAPI (BF, BJ, CF, CG, CI, CM, GA, GN, GQ, GW, KM, ML, MR, NE, SN, TD, TG).

**Declarations under Rule 4.17:**

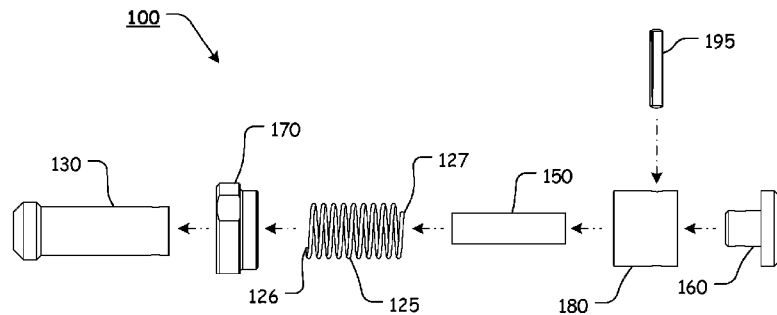
— of inventorship (Rule 4.17(iv))

**Published:**

— without international search report and to be republished upon receipt of that report (Rule 48.2(g))

WO 2017/014862 A2

(54) Title: RECOIL MANAGEMENT SYSTEM



**FIG. 36**

(57) Abstract: A recoil management system having a buffer element with a buffer element body portion, a buffer element knob, and a buffer element cavity; a collar; a sleeve, wherein a sleeve recess is formed so as to accept at least a portion of the buffer element body portion therein; a buffer element recoil spring, wherein the buffer element recoil spring is positioned about at least a portion of the elongate buffer element body portion, between the collar and the sleeve; and a bumper, wherein a bumper extension portion extends from a first end of the bumper to a bumper shoulder, wherein the bumper extension portion is such that at least a portion of the bumper extension portion can be fitted at least partially within the sleeve aperture.

**RECOIL MANAGEMENT SYSTEM**

**CROSS-REFERENCE TO RELATED APPLICATIONS**

5 **[0001]** This application claims the benefit of U.S. Patent Application Ser. No. 14/738,607, filed June 12, 2015, now U.S. Patent No. 9,341,437, issued May 17, 2016, and U.S. Patent Application Ser. No. 14/922,152, filed October 24, 2015, the disclosures of which are incorporated herein in their entireties by reference.

10 **STATEMENT REGARDING FEDERALLY SPONSORED RESEARCH OR DEVELOPMENT**

**[0002]** Not Applicable.

15 **REFERENCE TO SEQUENCE LISTING, A TABLE, OR A COMPUTER PROGRAM LISTING COMPACT DISC APPENDIX**

**[0003]** Not Applicable.

**NOTICE OF COPYRIGHTED MATERIAL**

20 **[0004]** The disclosure of this patent document contains material that is subject to copyright protection. The copyright owner has no objection to the reproduction by anyone of the patent document or the patent disclosure, as it appears in the Patent and Trademark Office patent file or records, but otherwise reserves all copyright rights whatsoever. Unless otherwise noted, all trademarks and service marks identified herein are owned by the  
25 applicant.

## BACKGROUND OF THE INVENTION

### 1. Field of the Invention

**[0005]** The present disclosure relates generally to the field of firearms.

5 More specifically, the present disclosure relates to a recoil management system for a firearm.

### 2. Description of Related Art

**[0006]** The AR-15 is based on the AR-10, which was designed by  
10 Eugene Stoner, Robert Fremont, and L. James Sullivan of the Fairchild ArmaLite Corporation in 1957. Today, there are numerous variants of the AR-15 that are manufactured by a number of companies. The AR-15 and its various related derivative platforms are used by civilians, law enforcement personnel, and military forces around the world.

15 **[0007]** Various firearms, such as, for example, the AR-15 or M-4 style firearms utilize a variable position buttstock **2** that is slidable and lockable at various positions along a buffer tube **5**. A typical variable position buttstock **2** can be locked into a collapsed position, as illustrated in **FIG. 1**, or locked into a fully extended position, as illustrated in **FIG. 2**.

20 **[0008]** As further illustrated in **Figs. 3** and **4**, the typical buffer tube **2** includes a capped cylindrical portion having a threaded portion **8** for installation into a buffer tube receiving aperture **11** of a lower receiver **10**. Typically, an endplate **6** and a lock ring **4** are utilized to complete installation of the buffer tube **5** on the receiver. A key protrusion **7** extends from the  
25 cylindrical portion **9**, typically at the 6 o'clock position. An interior portion of the key protrusion includes a plurality of spaced apart recesses or apertures that interact with a retractable bolt to lock the buttstock **2** in a desired position relative to the buffer tube **5**.

**[0009]** During normal operation of a semiautomatic AR-15 style rifle,  
30 when a round is fired, gas from the burning propellant forces the bullet through the barrel. Before the bullet leaves the barrel, a portion of the gas enters a gas port in the upper part of the barrel under the front sight (or gas

block). The gas port directs gas through a portion of the front sight (or gas block) and into the gas tube, which directs the gas into a cylinder between the bolt carrier **13** and the bolt and drives the bolt carrier **13** rearward.

**[0010]** The buffer **3**, which is pushing on the rear of the bolt carrier group, is forced rearward by the bolt carrier group, compressing the recoil spring **1**. During this rearward movement, a cam track in the upper portion of the bolt carrier **13** acts on the bolt cam pin, rotating the cam pin and bolt clockwise so that the bolt locking lugs are unlocked from the barrel extension locking lugs. As the rearward movement of the bolt carrier group continues, the empty cartridge case is extracted from the chamber, and ejected through the ejection port.

**[0011]** As the bolt carrier group clears the top of an inserted magazine and the empty cartridge case is expelled, a new round is pushed into the path of the bolt by the upward thrust of the magazine follower and spring.

**[0012]** As the bolt carrier group continues to move rearward, it overrides the hammer and forces the hammer down into the receiver, compressing the hammer spring, and allowing the rear hook of the hammer to engage with the hammer disconnect.

**[0013]** When the bolt carrier group reaches its rearmost position (when the rear of the buffer **3** contacts the bottom wall at the rear of the buffer tube **5**), the compressed recoil spring **1** expands, driving the buffer assembly forward with enough force to drive the bolt carrier group forward, toward the chamber, initiating chambering of the waiting round from the magazine into the chamber.

**[0014]** The forward movement of the bolt ceases when the locking lugs pass between the barrel extension locking lugs and the round is fully chambered. When the bolt carrier **13** enters the final portion of its forward movement, the bolt cam pin emerges from the cam pin guide channel in the upper receiver and moves along the cam track, rotating the bolt counterclockwise. This rotation locks the bolt to the barrel extension (by interaction of the bolt locking lugs and the barrel extension locking lugs). The locking of the bolt completes the cycle of operation and, when the

trigger is released, the rear hammer hook hammer slips from the disconnect and the front hammer hook is caught by the sear of the trigger. The firearm is then ready to be fired again.

**[0015]** Any discussion of documents, acts, materials, devices, articles, or  
5 the like, which has been included in the present specification is not to be  
taken as an admission that any or all of these matters form part of the prior  
art base or were common general knowledge in the field relevant to the  
present disclosure as it existed before the priority date of each claim of this  
application.

10

### **BRIEF SUMMARY OF THE INVENTION**

**[0016]** Unfortunately, the typical buffer tube **5** must be relatively lengthy to accommodate the recoil spring **1**, the buffer **3**, and a rear portion of the bolt carrier **13** (during the firing cycle). This results in a buffer tube **5** that is  
5 relatively lengthy, heavy, and cumbersome.

**[0017]** Additionally, attempts to produce compact buffer tube assemblies rely on a design that incorporates the bolt carrier and the buffer into a combined assembly that is either fixed, pinned, or connected by an adapter. This single unit design does not allow the user to "shotgun" the upper and  
10 requires that the user incorporate a proprietary bolt carrier.

**[0018]** Furthermore, known buffers do not take advantage of the weight of the buffer element body as part of the dead blow reciprocating mass. Thus, mass of the known buffer is wasted.

**[0019]** The disadvantages and shortcomings of the prior art are  
15 overcome by the features and elements of the recoil management system of the present disclosure. The advantages of the present disclosure are preferably attained by providing, in an exemplary, nonlimiting embodiment, a recoil management system, comprising a buffer tube, wherein the buffer tube comprises an elongate portion of material extending, along a  
20 longitudinal axis, from a first end to a second end and having an internal buffer tube cavity defined by an open end, one or more side walls, and a bottom wall; a buffer tube recoil spring, wherein the buffer tube recoil spring extends from a first end to a second end; a buffer element, wherein the buffer element comprises an elongate buffer element body portion extending  
25 from a buffer element knob, wherein the buffer element comprises a buffer element cavity defined by an open end, one or more side walls, and a bottom wall; a collar, wherein a collar aperture is formed through the collar, along a longitudinal axis of the collar, wherein a substantially cylindrical collar recess extends from a first end of the collar and is defined by one or  
30 more side walls and a collar recess shoulder; a sleeve, wherein a sleeve aperture is formed through the sleeve, along a longitudinal axis of the sleeve, wherein the sleeve aperture is formed so as to accept at least a

portion of the bumper therein, wherein a substantially cylindrical sleeve recess extends from a first end of the sleeve and is defined by one or more side walls and a sleeve recess shoulder, wherein the sleeve recess is formed so as to accept at least a portion of the buffer element body portion therein; a buffer element recoil spring, wherein the buffer element recoil spring is positioned about at least a portion of the elongate buffer element body portion, between the collar and the sleeve; and a bumper, wherein a bumper extension portion extends from a first end of the bumper to a bumper shoulder, wherein the bumper extension portion is such that at least a portion of the bumper extension portion can be fitted at least partially within the sleeve aperture.

**[0020]** In still other exemplary, nonlimiting embodiments, a recoil management system is provided that comprises a buffer element, wherein the buffer element extends from an elongate buffer element body portion to a buffer element knob, wherein the buffer element comprises a buffer element cavity defined by an open end, one or more side walls, and a bottom wall; a collar, wherein a collar aperture is formed through the collar, along a longitudinal axis of the collar, wherein a substantially cylindrical collar recess extends from a first end of the collar and is defined by one or more side walls and a collar recess shoulder; a sleeve, wherein a sleeve aperture is formed through the sleeve, along a longitudinal axis of the sleeve, wherein a substantially cylindrical sleeve recess extends from a first end of the sleeve and is defined by one or more side walls and a sleeve recess shoulder, wherein the sleeve recess is formed so as to accept at least a portion of the buffer element body portion therein; a buffer element recoil spring, wherein the buffer element recoil spring is positioned about at least a portion of the elongate buffer element body portion, between the collar and the sleeve; and a bumper, wherein a bumper extension portion extends from a first end of the bumper to a bumper shoulder, wherein the bumper extension portion is such that at least a portion of the bumper extension portion can be fitted at least partially within the sleeve aperture.

**[0021]** Accordingly, the presently disclosed systems, methods, and/or

apparatuses provide a recoil management system that allows for the use of a shortened, more compact buffer tube.

**[0022]** The presently disclosed systems, methods, and/or apparatuses separately provide a recoil management system that utilizes at least a buffer  
5 tube recoil spring and a buffer element recoil spring.

**[0023]** The presently disclosed systems, methods, and/or apparatuses separately provide a recoil management system that provides recoil management with a buffer element requiring a shorter distance of travel.

**[0024]** The presently disclosed systems, methods, and/or apparatuses  
10 separately provide a recoil management system that can be utilized in conjunction with a standard bolt carrier.

**[0025]** The presently disclosed systems, methods, and/or apparatuses separately provide a recoil management system that allows the user to “shotgun” the upper receiver.

**[0026]** The presently disclosed systems, methods, and/or apparatuses  
15 separately provide a recoil management system that utilizes various components of the buffer assembly as part of a reciprocating mass.

**[0027]** The presently disclosed systems, methods, and/or apparatuses separately provide a recoil management system that provides and “dead  
20 below” effect.

**[0028]** The presently disclosed systems, methods, and/or apparatuses separately provide a recoil management system that allows a rifle operating system to be “tuned”.

**[0029]** The presently disclosed systems, methods, and/or apparatuses  
25 separately provide a recoil management system that can be easily assembled and/or retrofitted by a user.

**[0030]** These and other aspects, features, and advantages of the present disclosure are described in or are apparent from the following detailed description of the exemplary, non-limiting embodiments of the present  
30 disclosure and the accompanying figures. Other aspects and features of embodiments of the present disclosure will become apparent to those of ordinary skill in the art upon reviewing the following description of specific,

exemplary embodiments of the present disclosure in concert with the figures. While features of the present disclosure may be discussed relative to certain embodiments and figures, all embodiments of the present disclosure can include one or more of the features discussed herein. Further, while one or  
5 more embodiments may be discussed as having certain advantageous features, one or more of such features may also be used with the various embodiments of the systems, methods, and/or apparatuses discussed herein. In similar fashion, while exemplary embodiments may be discussed below as device, system, or method embodiments, it is to be understood that  
10 such exemplary embodiments can be implemented in various devices, systems, and methods of the present disclosure.

**[0031]** Any benefits, advantages, or solutions to problems that are described herein with regard to specific embodiments are not intended to be construed as a critical, required, or essential feature(s) or element(s) of the  
15 present disclosure or the claims.

**BRIEF DESCRIPTION OF THE SEVERAL VIEWS OF THE DRAWINGS**

**[0032]** As required, detailed exemplary embodiments of the present disclosure are disclosed herein; however, it is to be understood that the disclosed embodiments are merely exemplary of the systems, methods, and/or apparatuses that may be embodied in various and alternative forms, within the scope of the present disclosure. The figures are not necessarily to scale; some features may be exaggerated or minimized to illustrate details of particular components. Therefore, specific structural and functional details disclosed herein are not to be interpreted as limiting, but merely as a basis for the claims and as a representative basis for teaching one skilled in the art to employ the present disclosure.

**[0033]** The exemplary embodiments of the presently disclosed systems, methods, and/or apparatuses will be described in detail, with reference to the following figures, wherein like reference numerals refer to like parts throughout the several views, and wherein:

**[0034]** **FIG. 1** illustrates a side view of a standard, AR-15 or M4 style rifle having a collapsible buttstock, shown in a collapsed position relative to a standard buffer tube;

**[0035]** **FIG. 2** illustrates a side view of a standard, AR-15 or M4 style rifle having a collapsible buttstock, shown in an extended position relative to a standard buffer tube;

**[0036]** **FIG. 3** illustrates a side, cross-sectional view of a standard buffer fitted within a standard buffer tube;

**[0037]** **FIG. 4** illustrates a front view of a standard buffer fitted within a standard buffer tube;

**[0038]** **FIG. 5** illustrates an upper, front perspective view of an exemplary embodiment of a compact buffer tube, according to the presently disclosed systems, methods, and/or apparatuses;

**[0039]** **FIG. 6** illustrates an upper, rear perspective view of an exemplary embodiment of a compact buffer tube, according to the presently disclosed systems, methods, and/or apparatuses;

**[0040]** FIG. 7 illustrates a side view of an exemplary embodiment of a compact buffer tube, according to the presently disclosed systems, methods, and/or apparatuses;

**[0041]** FIG. 8 illustrates a side cross-sectional view taken along line 8-8 of the compact buffer tube of FIG. 7, according to the presently disclosed systems, methods, and/or apparatuses;

**[0042]** FIG. 9 illustrates a perspective cross-sectional view taken along line 8-8 of the compact buffer tube of FIG. 7, according to the presently disclosed systems, methods, and/or apparatuses;

**[0043]** FIG. 10 illustrates an upper, rear perspective view of an exemplary embodiment of a buffer element, according to the presently disclosed systems, methods, and/or apparatuses;

**[0044]** FIG. 11 illustrates an upper, front perspective view of an exemplary embodiment of a buffer element, according to the presently disclosed systems, methods, and/or apparatuses;

**[0045]** FIG. 12 illustrates a front view of an exemplary embodiment of a buffer element, according to the presently disclosed systems, methods, and/or apparatuses;

**[0046]** FIG. 13 illustrates a rear view of an exemplary embodiment of a buffer element, according to the presently disclosed systems, methods, and/or apparatuses;

**[0047]** FIG. 14 illustrates a top view of an exemplary embodiment of a buffer element, according to the presently disclosed systems, methods, and/or apparatuses;

**[0048]** FIG. 15 illustrates a side view of an exemplary embodiment of a buffer element, according to the presently disclosed systems, methods, and/or apparatuses;

**[0049]** FIG. 16 illustrates a cross-sectional view taken along line 16-16 of the buffer element of FIG. 14, according to the presently disclosed systems, methods, and/or apparatuses;

**[0050]** FIG. 17 illustrates an upper, front perspective view of an exemplary embodiment of a bumper, according to the presently disclosed systems, methods, and/or apparatuses;

5 **[0051]** FIG. 18 illustrates an upper, rear perspective view of an exemplary embodiment of a bumper, according to the presently disclosed systems, methods, and/or apparatuses;

**[0052]** FIG. 19 illustrates a top view of an exemplary embodiment of a bumper, according to the presently disclosed systems, methods, and/or apparatuses;

10 **[0053]** FIG. 20 illustrates a side view of an exemplary embodiment of a bumper, according to the presently disclosed systems, methods, and/or apparatuses;

**[0054]** FIG. 21 illustrates a cross-sectional view taken along line 21-21 of the bumper of FIG. 19, according to the presently disclosed systems, methods, and/or apparatuses;

15 **[0055]** FIG. 22 illustrates an upper, front perspective view of an exemplary embodiment of a collar, according to the presently disclosed systems, methods, and/or apparatuses;

20 **[0056]** FIG. 23 illustrates an upper, rear perspective view of an exemplary embodiment of a collar, according to the presently disclosed systems, methods, and/or apparatuses;

**[0057]** FIG. 24 illustrates a rear view of an exemplary embodiment of a collar, according to the presently disclosed systems, methods, and/or apparatuses;

25 **[0058]** FIG. 25 illustrates a front view of an exemplary embodiment of a collar, according to the presently disclosed systems, methods, and/or apparatuses;

30 **[0059]** FIG. 26 illustrates a side view of an exemplary embodiment of a collar, according to the presently disclosed systems, methods, and/or apparatuses;

**[0060]** FIG. 27 illustrates a cross-sectional view taken along line 27-27 of the collar of FIG. 24, according to the presently disclosed systems, methods, and/or apparatuses;

5 **[0061]** FIG. 28 illustrates an upper, front perspective view of an exemplary embodiment of a sleeve, according to the presently disclosed systems, methods, and/or apparatuses;

**[0062]** FIG. 29 illustrates an upper, rear perspective view of an exemplary embodiment of a sleeve, according to the presently disclosed systems, methods, and/or apparatuses;

10 **[0063]** FIG. 30 illustrates a front view of an exemplary embodiment of a sleeve, according to the presently disclosed systems, methods, and/or apparatuses;

**[0064]** FIG. 31 illustrates a rear view of an exemplary embodiment of a sleeve, according to the presently disclosed systems, methods, and/or apparatuses;

15 **[0065]** FIG. 32 illustrates a top view of an exemplary embodiment of a sleeve, according to the presently disclosed systems, methods, and/or apparatuses;

**[0066]** FIG. 33 illustrates a right side view of an exemplary embodiment of a sleeve, according to the presently disclosed systems, methods, and/or apparatuses;

**[0067]** FIG. 34 illustrates a left side view of an exemplary embodiment of a sleeve, according to the presently disclosed systems, methods, and/or apparatuses;

25 **[0068]** FIG. 35 illustrates a cross-sectional view taken along line 35-35 of the sleeve of FIG. 32, according to the presently disclosed systems, methods, and/or apparatuses;

**[0069]** FIG. 36 illustrates an left side, exploded view of certain exemplary components of an exemplary embodiment of a recoil management system, according to the presently disclosed systems, methods, and/or apparatuses;

**[0070]** FIG. 37 illustrates a left side view of an exemplary embodiment of an assembled, recoil management system, according to the presently disclosed systems, methods, and/or apparatuses;

5 **[0071]** FIG. 38 illustrates a left side, cross-sectional view of an exemplary embodiment of an assembled, recoil management system, according to the presently disclosed systems, methods, and/or apparatuses, wherein the components are in an uncompressed position;

10 **[0072]** FIG. 39 illustrates a left side, cross-sectional view of an exemplary embodiment of an assembled, recoil management system, according to the presently disclosed systems, methods, and/or apparatuses, wherein the components are in a fully compressed position;

**[0073]** FIG. 40 illustrates a left side, exploded view of certain exemplary components of an exemplary embodiment of a recoil management system, according to the presently disclosed systems, methods, and/or apparatuses;

15 **[0074]** FIG. 41 illustrates a left side, cross-sectional, exploded view of certain exemplary components of an exemplary embodiment of a recoil management system of FIG. 40, according to the presently disclosed systems, methods, and/or apparatuses;

20 **[0075]** FIG. 42 illustrates a left side, cross-sectional view of certain exemplary components of an exemplary embodiment of a recoil management system, assembled according to the presently disclosed systems, methods, and/or apparatuses, wherein the components are in a normal, installed position;

25 **[0076]** FIG. 43 illustrates a left side, cross-sectional view of certain exemplary components of an exemplary embodiment of a recoil management system, assembled according to the presently disclosed systems, methods, and/or apparatuses, wherein the components are in a partially compressed position;

30 **[0077]** FIG. 44 illustrates a left side, cross-sectional view of certain exemplary components of an exemplary embodiment of a recoil management system, assembled according to the presently disclosed

systems, methods, and/or apparatuses, wherein the components are in a further compressed position;

**[0078]** FIG. 45 illustrates a left side, cross-sectional view of certain exemplary components of an exemplary embodiment of a recoil

5 management system, assembled according to the presently disclosed systems, methods, and/or apparatuses, wherein the components are in a fully compressed position;

**[0079]** FIG. 46 illustrates a left side, view of an exemplary embodiment of a recoil management system being assembled together with a lower

10 receiver, according to the presently disclosed systems, methods, and/or apparatuses;

**[0080]** FIG. 47 illustrates a left side, cross-sectional view of certain exemplary components of an exemplary embodiment of a recoil management system being assembled together with a lower receiver,

15 according to the presently disclosed systems, methods, and/or apparatuses;

**[0081]** FIG. 48 illustrates a left side, cross-sectional view of an exemplary embodiment of an assembled, recoil management system, according to the presently disclosed systems, methods, and/or apparatuses;

**[0082]** FIG. 49 illustrates a side view of an exemplary embodiment of a buffer element, according to the presently disclosed systems, methods, and/or apparatuses;

20 **[0083]** FIG. 50 illustrates a left side, cross-sectional view of an exemplary embodiment of a sleeve, according to the presently disclosed systems, methods, and/or apparatuses;

25 **[0084]** FIG. 51 illustrates an left side, exploded view of certain exemplary components of an exemplary embodiment of a recoil management system, according to the presently disclosed systems, methods, and/or apparatuses; and

30 **[0085]** FIG. 52 illustrates an left side, cross-sectional view of an exemplary embodiment of an assembled, recoil management system, according to the presently disclosed systems, methods, and/or apparatuses, wherein the components are in an uncompressed position.

### **DETAILED DESCRIPTION OF THE INVENTION**

**[0086]** For simplicity and clarification, the design factors and operating principles of the recoil management system according to the presently disclosed systems, methods, and/or apparatuses are explained with  
5 reference to various exemplary embodiments of a recoil management system according to the presently disclosed systems, methods, and/or apparatuses. The basic explanation of the design factors and operating principles of the recoil management system is applicable for the understanding, design, and operation of the recoil management system of  
10 the presently disclosed systems, methods, and/or apparatuses. It should be appreciated that the recoil management system can be adapted to many applications where a recoil management system or strap can be used.

**[0087]** As used herein, the word “may” is meant to convey a permissive sense (*i.e.*, meaning “having the potential to”), rather than a mandatory sense (*i.e.*, meaning “must”). Unless stated otherwise, terms such as “first” and “second” are used to arbitrarily distinguish between the elements such terms describe. Thus, these terms are not necessarily intended to indicate temporal or other prioritization of such elements.

**[0088]** The term “coupled”, as used herein, is defined as connected, although not necessarily directly, and not necessarily mechanically. The terms “a” and “an” are defined as one or more unless stated otherwise.  
20

**[0089]** Throughout this application, the terms “comprise” (and any form of comprise, such as “comprises” and “comprising”), “have” (and any form of have, such as “has” and “having”), “include”, (and any form of include, such as “includes” and “including”) and “contain” (and any form of contain, such as “contains” and “containing”) are used as open-ended linking verbs. It will be understood that these terms are meant to imply the inclusion of a stated element, integer, step, or group of elements, integers, or steps, but not the exclusion of any other element, integer, step, or group of elements, integers, or steps. As a result, a system, method, or apparatus that “comprises”,  
25 “has”, “includes”, or “contains” one or more elements possesses those one or more elements but is not limited to possessing only those one or more  
30

elements. Similarly, a method or process that “comprises”, “has”, “includes” or “contains” one or more operations possesses those one or more operations but is not limited to possessing only those one or more operations.

5 **[0090]** It should also be appreciated that the terms “recoil management system”, “buffer assembly”, “lower receiver”, and “firearm” are used for basic explanation and understanding of the operation of the presently disclosed systems, methods, and/or apparatuses. Therefore, the terms “recoil management system”, “buffer assembly”, “lower receiver”, and “firearm” are  
10 not to be construed as limiting the systems, methods, and/or apparatuses of the present disclosure. Thus, for example, the term “lower receiver” is to be understood to broadly include any upper, lower, or combined receiver for a firearm or other similar handheld or shoulder mounted device or tool.

**[0091]** For simplicity and clarification, the recoil management system of  
15 the present disclosure will be described as being used in conjunction with a firearm, such as an AR-15 or M4 style rifle or carbine. However, it should be appreciated that these are merely exemplary embodiments of the recoil management system and are not to be construed as limiting the presently disclosed systems, methods, and/or apparatuses. Thus, the recoil  
20 management system of the present disclosure may be utilized in conjunction with any firearm or rifle, such as, for example, an AR-10 style rifle, air rifle, paintball marker, Airsoft rifle, replica rifle, or any other tool, device, or object.

**[0092]** Turning now to the drawing **Figs.**, as discussed above, **FIG. 1-4** illustrate various components of known buffer tubes. **Figs. 5-48** illustrate  
25 certain elements and/or aspects of an exemplary embodiment of the recoil management system **100**, according to the presently disclosed systems, methods, and/or apparatuses. In illustrative, non-limiting embodiment(s) of the present disclosure, as illustrated in **Figs. 5-48**, the recoil management system **100** comprises at least some of a receiver extension or buffer tube  
30 **110**, a buffer tube recoil spring **120**, a buffer element recoil spring **125**, a buffer element **130**, a weight **150**, a bumper **160**, a collar **170**, and a sleeve **180**.

**[0093]** As illustrated most clearly in **Figs. 5-9**, the receiver extension or buffer tube **110** comprises an elongate portion of material extending, along a longitudinal axis  $A_L$ , from a first end to a second end and having a substantially cylindrical internal cavity **115** defined by one or more side walls **113** and a bottom wall **114**. The internal cavity **115** extends from the bottom wall **114**, along the one or more side walls **113**, to an open end **112**.

**[0094]** In various exemplary embodiments, the buffer tube **110** includes an externally threaded portion **111**, which extends from the first end. The externally threaded portion **111**, if included, allows the buffer tube **110** to be threadedly attached or connected to the lower receiver **10**, via interaction of the externally threaded portion **111** of the buffer tube **110** and an internally threaded buffer tube receiving aperture **11** of the lower receiver **10**.

**[0095]** Alternatively, the portion of the buffer tube **110** represented by the externally threaded portion **111** may comprise a smooth or textured surface that allows the buffer tube **110** to be welded or adhesively attached or coupled to a corresponding buffer tube receiving aperture of a lower receiver. Thus, the buffer tube **110** may be attached, connected, or coupled to a lower receiver in any desired manner. In still other exemplary embodiments, the buffer tube **110** may be formed as an integral component of a lower receiver.

**[0096]** The overall length of the buffer tube **110** is substantially shorter than a known, typical buffer tube **5**. Thus, the buffer tube **110** can be utilized in conjunction with, for example, retractable buttstocks that provide a shorter overall length to the buttstock assembly and/or firearm. Alternatively, the buffer tube **110** can be utilized in conjunction with certain pistol configurations to provide a shorter overall length to the firearm.

**[0097]** In various exemplary embodiments, the buffer tube **110** is substantially rigid and is formed of aluminum. Alternate materials of construction of the buffer tube **110** may include one or more of the following: steel, stainless steel, titanium, and/or other metals, as well as various alloys and composites thereof, glass-hardened polymers, polymeric composites, polymer or fiber reinforced metals, carbon fiber or glass fiber composites,

continuous fibers in combination with thermoset and thermoplastic resins, chopped glass or carbon fibers used for injection molding compounds, laminate glass or carbon fiber, epoxy laminates, woven glass fiber laminates, impregnate fibers, polyester resins, epoxy resins, phenolic resins, polyimide resins, cyanate resins, high-strength plastics, nylon, glass, or polymer fiber reinforced plastics, thermoform and/or thermoset materials, and/or various combinations of the foregoing. Thus, it should be understood that the material or materials used to form the buffer tube **110** is a design choice based on the desired appearance and/or functionality of the buffer tube **110**.

**[0098]** The buffer tube recoil spring **120** extends from a first end **121** to a second end **122**. In various exemplary embodiments, the buffer tube recoil spring **120** comprises a standard AR buffer spring, having a reduced length. In certain exemplary, nonlimiting embodiments, the buffer tube recoil spring **120** comprises a standard AR buffer spring that has been shortened.

**[0099]** The buffer element recoil spring **125** extends from a first end to a second end. The buffer element recoil spring **125** has an external diameter that is less than an internal diameter of the buffer tube recoil spring **120**. In this manner, when assembled, the buffer element recoil spring **125** can be fitted within the buffer tube recoil spring **120**.

**[00100]** In various exemplary embodiments, the buffer element recoil spring **125** may optionally have a spring rate or spring biasing force that is less than a spring rate or spring biasing force of the buffer tube recoil spring **120**. In other exemplary embodiments, the buffer element recoil spring **125** may optionally have a spring rate or spring biasing force that is greater than a spring rate or spring biasing force of the buffer tube recoil spring **120**. In still other exemplary embodiments, the buffer element recoil spring **125** may optionally have a spring rate or spring biasing force that is equal to a spring rate or spring biasing force of the buffer tube recoil spring **120**. Thus, it should be appreciated that the spring rates or spring biasing forces of the buffer element recoil spring **125** and the buffer tube recoil spring **120** may be the same or may be different from one another.

**[00101]** It should be appreciated that the overall size and characteristics of the buffer tube recoil spring **120** and the buffer element recoil spring **125** are designed choices based upon the desired performance of the buffer tube recoil spring **120** and the buffer element recoil spring **125**. Additionally, the  
5 buffer tube recoil spring **120** and the buffer element recoil spring **125** may be formed of steel, spring-tempered steel, brass, phosphor bronze, or any other desired material.

**[00102]** In certain exemplary embodiments, the combined spring rate or spring biasing force of the buffer tube recoil spring **120** and the buffer  
10 element recoil spring **125** is approximately equivalent to the spring biasing force of a standard, MIL-SPEC carbine buffer spring rate or spring biasing force.

**[00103]** As illustrated most clearly in **Figs. 10-16**, the buffer element **130** comprises a buffer element body portion **135** and a buffer element knob **137**.  
15 The buffer element **130** comprises an elongate portion of material extending, along a longitudinal axis  $A_L$ , from a first end **131** to a second end **132**.

**[00104]** In various exemplary embodiments, the buffer element **130** includes a buffer element cavity **139** defined by one or more side walls **139'** and a bottom wall **139''**. The buffer element cavity **139** extends from the  
20 bottom wall **139''**, along the one or more side walls **139'**, to an open end **138**.

**[00105]** In various exemplary, nonlimiting embodiments, the buffer element **130** is formed of a partially or substantially solid portion of material and only includes a buffer element cavity **139** of a sufficient size to accept at least a  
25 portion of the bumper extension portion **163** of the end **160**.

**[00106]** In these exemplary, nonlimiting embodiments, the manufacturing time and cost of the buffer element **130** may be reduced. Furthermore, a solid buffer element **130** may provide sufficient weigh to be close to the reciprocating mass of a standard, MIL-SPEC carbine buffer.

**[00107]** The buffer element body portion **135** extends from the second end **132** to a bulbous portion or buffer element knob **137**. The buffer element knob **137** has a larger outer diameter than an outer diameter of the buffer

element body portion **135**.

**[00108]** In various exemplary embodiments, an optional second buffer element chamfer **136** is formed as a transitional edge or plane between the first end **131** and the outer surface of the buffer element knob **137**. The  
5 second buffer element chamfer **136** provides a transition between the buffer element body portion **135** and the buffer element knob **137**. In various exemplary embodiments, the second buffer element chamfer **136** extends at an angle that is approximately 135° relative to the longitudinal axis  $A_L$ , of the buffer element **130**. Alternatively, the second buffer element chamfer **136**  
10 may extend at an angle that is equal to, greater than, or less than 135° relative to the longitudinal axis  $A_L$ , of the buffer element **130**. For example, the second buffer element chamfer **136** may extend at an angle that is approximately 155°, 150°, 145°, 140°, 135°, 130°, 125°, 120°, or 115° relative to the longitudinal axis  $A_L$ , of the buffer element **130**.

**[00109]** An optional first buffer element chamfer **133** is formed as a transitional edge or plane between the buffer element knob **137** and the first end **131** of the buffer element **130**. The first buffer element chamfer **133** provides a transition between the buffer element knob **137** and the first end **131** of the buffer element **130**. In various exemplary embodiments, the first  
20 buffer element chamfer **133** extends at an angle that is approximately 45° relative to the longitudinal axis  $A_L$ , of the buffer element **130**. Alternatively, the first buffer element chamfer **133** may extend at an angle that is equal to, greater than, or less than 45° relative to the longitudinal axis  $A_L$ , of the buffer element **130**. For example, the first buffer element chamfer **133** may extend  
25 at an angle that is approximately 25°, 30°, 35°, 40°, 45°, 50°, 55°, 60°, or 65° relative to the longitudinal axis  $A_L$ , of the buffer element **130**.

**[00110]** A buffer element retaining pin aperture **191** extends at least partially through the buffer element body portion **135**, proximate the second end **132** and is formed so as to accept at least a portion of a retaining pin  
30 **195** therethrough.

**[00111]** In various exemplary embodiments, the buffer element **130** is substantially rigid and is formed of stainless steel. Alternate materials of

construction of the buffer element **130** may include one or more of the following: steel, aluminum, titanium, and/or other metals, as well as various alloys and composites thereof. Thus, it should be understood that the material or materials used to form the buffer element **130** is a design choice  
5 based on the desired appearance and/or functionality of the buffer element **130**.

**[00112]** The weight **150** is generally cylindrical in shape and is sized so as to be fitted within the buffer element cavity **139** of the buffer element **130**. The actual weight of the weight **150** can vary, depending upon the desired  
10 functionality of the weight **150** and the overall functional weight of the buffer element **130**. In various exemplary embodiments, the weight **150** may comprise a portion of stainless steel or tungsten rod. Alternatively, the weight **150** may comprise a solid portion of material, a powdered or granulated material (such as, for example, loose sand, lead, steel, or other  
15 metallic or nonmetallic shot), or a liquid (such as, for example, Mercury).

**[00113]** As illustrated most clearly in **Figs. 17-21**, the bumper **160** comprises a portion of material extending, along a longitudinal axis  $A_L$ , from a first end **161** to a second end **162**. In various exemplary embodiments, a bumper extension portion **163** extends rearward from the first end **161**. The  
20 bumper extension portion **163** extends from the first end **161** to a bumper shoulder **164**. In various exemplary embodiments, the bumper extension portion **163** extends parallel to the longitudinal axis  $A_L$ , of the bumper **160** and the bumper shoulder **164** extends perpendicular to the longitudinal axis  $A_L$ , of the bumper **160**. Alternatively, the bumper shoulder **164** may extend  
25 at an angle that is equal to, greater than, or less than  $90^\circ$  relative to the longitudinal axis  $A_L$ , of the bumper **160**.

**[00114]** The outer size and shape of the bumper extension portion **163** is such that at least a portion of the bumper extension portion **163** can be fitted through the open end **138** of the buffer element cavity **139** and positioned  
30 within at least a portion of the buffer element cavity **139**.

**[00115]** A bumper head portion **165** extends rearward from the bumper shoulder **164** to the second end **162**. In various exemplary embodiments,

the bumper head portion **165** has an overall dome or a tapered shape. Alternatively, the bumper head portion **165** may comprise a generally cylindrical overall shape.

**[00116]** In various exemplary embodiments, the bumper head portion **165**  
5 has a larger outer diameter or size than an outer diameter or size of the bumper extension portion **163**. Thus, the bumper shoulder **164** provides a transition between the bumper head portion **165** and the bumper extension portion **163**.

**[00117]** A bumper retaining aperture **167** extends at least partially through  
10 the bumper extension portion **163** and is formed so as to accept at least a portion of a retaining pin **195** therethrough.

**[00118]** In various exemplary embodiments, the bumper **160** is substantially rigid and is formed of urethane. Alternatively, the bumper **160** may be substantially deformable or flexible and alternate materials of  
15 construction of the bumper **160** may include one or more of the following: rubber, silicone, plastic, self-lubricating plastic, glass-hardened polymers, polymeric composites, polymer or fiber reinforced metals, carbon fiber or glass fiber composites, continuous fibers in combination with thermoset and thermoplastic resins, chopped glass or carbon fibers used for injection  
20 molding compounds, laminate glass or carbon fiber, epoxy laminates, woven glass fiber laminates, impregnate fibers, polyester resins, epoxy resins, phenolic resins, polyimide resins, cyanate resins, high-strength plastics, nylon, glass, or polymer fiber reinforced plastics, thermoform and/or thermoset materials, and/or various combinations or variations of the  
25 foregoing. Thus, it should be understood that the material or materials used to form the bumper **160** is a design choice based on the desired appearance and/or functionality of the bumper **160**.

**[00119]** As illustrated most clearly in **Figs. 22-27**, the collar **170** comprises a portion of material extending, along a longitudinal axis  $A_L$ , from a first end  
30 **171** to a second end **172**. A collar aperture **176** is formed through the collar **170**, along the longitudinal axis  $A_L$ . A substantially cylindrical collar recess **173** extends from the first end **171** and is defined by one or more side walls

and a collar recess shoulder **174**. The collar recess **173** is formed so as to accept at least a portion of the buffer element knob **137** therein.

**[00120]** In various exemplary embodiments, the collar recess shoulder **174** extends perpendicular to the longitudinal axis  $A_L$ , of the collar **170**.

5 Alternatively, as illustrated, the collar recess shoulder **174** may extend at an angle that is greater than or less than  $90^\circ$  relative to the longitudinal axis  $A_L$ , of the collar **170**. Generally, the collar recess **173** is formed so as to accept at least a portion of the buffer element knob **137** therein and the collar recess shoulder **174** is formed so as to mate with at least a portion of the  
10 second buffer element chamfer **136**, when the buffer element knob **137** is at least partially seated within the collar recess **173**.

**[00121]** In certain exemplary embodiments, one or more recesses or notches **173'** extend from the collar recess **173**. If included, the recesses or notches **173'** provide debris channels, such that any matter or debris that  
15 comes between the collar **170** and the buffer element **130** can be diverted into the recesses or notches **173'**, so as not to hinder the movement of the collar **170** in relation to the buffer element **130**.

**[00122]** In various exemplary embodiments, the collar aperture **176** has a diameter that is less than a diameter of the collar recess **173** and allows the  
20 buffer element body portion **135** to be slidable within the collar aperture **176**.

**[00123]** A substantially cylindrical collar spring recess **177** extends from the second end **172** and is defined by one or more side walls and a collar spring recess shoulder **179**. The collar spring recess **177** is formed so as to accept at least a portion of the buffer element recoil spring **125** therein.

25 **[00124]** In various exemplary embodiments, as illustrated, the collar spring recess shoulder **179** extends perpendicular to the longitudinal axis  $A_L$ , of the collar **170**. Alternatively, the collar spring recess shoulder **179** may extend at an angle that is greater than or less than  $90^\circ$  relative to the longitudinal axis  $A_L$ , of the collar **170**. Generally, the collar spring recess shoulder **179** is  
30 formed so as to be a contact surface for the second end **126** of the buffer element recoil spring **125**, when the buffer element recoil spring **125** is at least partially seated within the collar spring recess **177**.

**[00125]** In various exemplary embodiments, the collar **170** has a substantially circular profile, when viewed from the front or rear. In various exemplary embodiments, one or more grooves, notches, or flats **175'** are formed at various locations around the collar **170**. If included, the flats **175'** may optionally reduce the overall weight of the collar **170**, provide less friction to the collar **170**, and/or provide areas for dirt, debris, or other material to pass by portions of the collar **170**. It should be appreciated that the overall profile of the collar **170** may comprise for example, an overall profile resembling that of a circle, triangle, square, pentagon, hexagon, heptagon, octagon, star shape, or other desired shape.

**[00126]** Regardless of the overall shape or profile of the collar **170**, the outer diameter or extent of the collar **170** is such that the collar **170** fits within and is slidable within the internal cavity **115** of the buffer tube **110**.

**[00127]** In various exemplary embodiments, the collar **170** is substantially rigid and is formed of aluminum. Alternate materials of construction of the collar **170** may include one or more of the following: steel, stainless steel, titanium, and/or other metals, as well as various alloys and composites thereof. Thus, it should be understood that the material or materials used to form the collar **170** is a design choice based on the desired appearance and/or functionality of the collar **170**.

**[00128]** As illustrated most clearly in **Figs. 28-35**, the sleeve **180** comprises a portion of material forming a sleeve body **183** that extends, along a longitudinal axis  $A_L$ , from a first end **181** to a second end **182**. A sleeve aperture **186** is formed through the sleeve **180**, along the longitudinal axis  $A_L$ . The sleeve aperture **186** is formed so as to accept at least a portion of the bumper **160** therein.

**[00129]** In various exemplary embodiments, the vertices of the first end **181** and the sleeve body **183** meet at a right angle, or  $90^\circ$ . Likewise, the vertices of the second end **182** and the sleeve body **183** meet at a right angle, or  $90^\circ$ .

**[00130]** A substantially cylindrical sleeve spring recess **185** extends from the first end **181** and is defined by one or more side walls and a sleeve

recess shoulder **184**. The sleeve spring recess **185** is formed so as to accept at least a portion of the buffer element body portion **135** therein, such that the sleeve retaining pin aperture **188** may be aligned with the buffer element retaining pin aperture **191** and the bumper retaining aperture **167**.

5 **[00131]** In various exemplary embodiments, as illustrated, the sleeve recess shoulder **184** extends substantially perpendicular to the longitudinal axis  $A_L$ , of the sleeve **180**. Alternatively, the sleeve recess shoulder **184** may extend at an angle that is greater than or less than  $90^\circ$  relative to the longitudinal axis  $A_L$ , of the sleeve **180**. Generally, the sleeve spring recess  
10 **185** is formed so as to accept at least a portion of the buffer element body portion **135** therein and the sleeve recess shoulder **184** is formed so as to mate with at least a portion of the second end **132** of the buffer element **130**, when the buffer element body portion **135** is at least partially seated within the sleeve spring recess **185**.

15 **[00132]** In various exemplary embodiments, the sleeve aperture **186** has a diameter that is less than a diameter of the sleeve spring recess **185** and allows the buffer element body portion **135** to be slidable within the sleeve spring recess **185**, until the second end **132** of the buffer element **130** contacts the sleeve recess shoulder **184**.

20 **[00133]** It should be appreciated that the outer diameter and shape of the sleeve body **183** is such that the sleeve **180** fits within and is slidable within the internal cavity **115** of the buffer tube **110**.

**[00134]** A sleeve retaining pin aperture **188** extends at least from an outer surface of the sleeve body **183** into the sleeve aperture **186**. In various  
25 exemplary embodiments, the sleeve retaining pin aperture **188** extends from a first side of the outer surface of the sleeve body **183**, through the sleeve aperture **186**, and through a second side of the outer surface of the sleeve body **183**.

**[00135]** In various exemplary embodiments, the sleeve **180** is substantially  
30 rigid and is formed of aluminum. Alternate materials of construction of the sleeve **180** may include one or more of the following: steel, stainless steel, titanium, and/or other metals, as well as various alloys and composites

thereof. Thus, it should be understood that the material or materials used to form the sleeve **180** is a design choice based on the desired appearance and/or functionality of the sleeve **180**.

**[00136]** As illustrated most clearly in **Figs. 36-47**, the various components of the buffer assembly **100** are fitted together and the buffer tube **110** is attached or coupled to an exemplary lower receiver **10**. As illustrated, during assembly, the buffer tube recoil spring **120** is inserted within the internal cavity **115** of the buffer tube **110**. The buffer tube recoil spring **120** is inserted within the internal cavity **115** such that the second end **122** of the buffer tube recoil spring **120** is in contact with the bottom wall **114** of the internal cavity **115**.

**[00137]** The collar **170** is slidably fitted about the buffer element body portion **135**, via interaction of the collar aperture **176** and the buffer element body portion **135**, such that the second buffer element chamfer **136** of the buffer element **130** contacts the collar recess shoulder **174** of the collar **170**.

**[00138]** The weight **150**, if included, is inserted within the buffer element cavity **139**.

**[00139]** The buffer element recoil spring **125** is slidably fitted about the buffer element body portion **135**, such that a portion of the recoil spring **125** is seated within the collar **170** and the second end **126** of the recoil spring **125** contacts the collar spring recess shoulder **179**, which extends at least partially into the collar aperture **176** of the collar **170**.

**[00140]** The sleeve **180** is slidably fitted about the buffer element body portion **135**, via interaction of the buffer element body portion **135** and the sleeve spring recess **185**, such that sleeve recess shoulder **187** of the sleeve **180** contacts the second end **132** of the buffer element **130**.

**[00141]** At least a portion of the bumper extension portion **163** is fitted through the sleeve aperture **186** of the sleeve **180**, such that the bumper retaining aperture **167** is aligned with the buffer element retaining pin aperture **191** and the sleeve retaining pin aperture **188**. In this configuration, the bumper shoulder **164** optionally contacts the second end **132** of the buffer element **130**.

**[00142]** Once the bumper **160** is appropriately positioned proximate the second end **132** of the buffer element **130**, the retaining pin **195** is positioned through the bumper retaining aperture **167**, the buffer element retaining pin aperture **191**, and the sleeve retaining pin aperture **188**.

5 **[00143]** When the sleeve **180** is attached or coupled to the buffer element **130**, the buffer element recoil spring **125** is captured between the collar **170** and the sleeve **180**, such that the second end **126** contacts the collar spring recess shoulder **179** and the first end **127** contacts the sleeve recess shoulder **184**. Because of the spring biasing force of the buffer element  
10 recoil spring **125**, the collar **170** is biased toward the first end **131** of the buffer element **130**.

**[00144]** Once the relevant components are attached or coupled to the buffer element **130**, the assembled buffer assembly **100** is positionable within the buffer tube recoil spring **120** such that the first end **121** of the  
15 buffer tube recoil spring **120** engages or contacts a shoulder **178** of the collar **170**.

**[00145]** During a firing cycle, as most clearly illustrated in **Figs. 42-45**, as the bolt carrier **13** is driven rearward, the rear of the bolt carrier **13** contacts the collar **170** and urges the collar **170** rearward, toward the bottom wall **114**  
20 of the buffer tube **110**. The rearward force exerted on the collar **170** urges the collar **170** and, in turn, the buffer element **130** rearward, within the interior cavity **115** of the buffer tube **110**.

**[00146]** As illustrated in **FIG. 43**, as the bolt carrier **13** continues to be driven rearward, the resilient spring biasing force of the buffer element recoil  
25 spring **125** continues to maintain the collar **170** in its position relative to the buffer element **130**, as the bolt carrier **130** continues rearward.

**[00147]** As illustrated in **FIG. 44**, as the bolt carrier **13** continues to be driven rearward, the second end **162** of the bumper **160** contacts the bottom wall **114** within the cavity **115** of the buffer tube **110**. If this occurs, and if the  
30 recoil force continues to drive the bolt carrier **13** rearward, the spring biasing force of the buffer element recoil spring **125** is overcome and the collar **170** compresses the buffer element recoil spring **125** as it travels rearward, along

the buffer element body portion **135**.

**[00148]** When the buffer assembly **100** transitions to a compressed position, the collar **170** compresses the buffer element recoil spring **125** and at least a portion of the buffer element knob **137** (and/or a portion of the  
5 buffer element body portion **135**) extends at least partially into an inside diameter of the bolt carrier **13**.

**[00149]** If the bolt carrier **13** continues to drive rearward after the second end **162** of the bumper **160** contacts the bottom wall **114** of the buffer tube **110**, the buffer element recoil spring **125** continues to compress, allowing  
10 the collar **170** to continue traveling rearward, along the buffer element body portion **135**. The collar **170** is in a fully compressed position, as illustrated in **FIG. 45**, when the surface of the second end **172** of the collar **170** contacts the surface of the first end **181** of the sleeve **180**.

**[00150]** If the buffer assembly **100** is in a fully compressed position, the  
15 compression of the buffer element recoil spring **125** is limited by the adjacent sleeve spring recess **185** and collar spring recess **177**.

**[00151]** In a fully compressed position, at least a portion of the collar spring recess **177** is aligned with the sleeve spring recess **185** to form a substantially continuous spring recess. The depth of the collar spring recess  
20 **177** is defined between the second end **172** of the collar **170** and the collar spring recess shoulder **179**. Similarly, the depth of the sleeve spring recess **185** is defined between the first end **181** of the sleeve **180** and the sleeve spring recess **185**.

**[00152]** By defining the overall length of the continuous spring recess  
25 defined by the collar spring recess **177** and the sleeve spring recess **185**, in a fully compressed position, the buffer element recoil spring **125** can only be compressed a determined amount. Thus, the continuous spring recess may be defined such that the buffer element recoil spring **125** maintains a determined travel distance. In certain exemplary embodiments, the  
30 determined travel distance is the safe travel distance for the buffer element recoil spring **125**. The safe travel distance is the distance that the buffer element recoil spring **125** can be compressed without deforming or over

compressing the buffer element recoil spring **125** or altering the desired, mechanical spring biasing properties of the buffer element recoil spring **125**. Typically, the safe travel distance is greater than the fully compressed height of the buffer element recoil spring **125**.

5 **[00153]** When the bolt carrier group reaches its rearmost position, the buffer tube recoil spring **120** and the buffer element recoil spring **125** both provide spring biasing force to the collar **170**, urging the collar **170** and the buffer element **130** forward. When the collar **170** contacts the buffer element knob **137**, the bolt carrier **13** and the buffer element **130** are urged  
10 forward with enough force to drive the bolt carrier **13** forward, toward the chamber, initiating chambering of the waiting round from the magazine into the chamber.

**[00154]** Thus, the buffer tube recoil spring **120** is first compressed by the rearward movement of the buffer element **130** (and more particularly the  
15 collar **170**) until the buffer tube recoil spring **120** is about to bottom out (is almost fully compressed). Then, if the second end **162** of the bumper **160** contacts the bottom wall **114** within the cavity **115** of the buffer tube **110**, the buffer element recoil spring **125** begins to compress. The buffer tube recoil spring **120** does not compress the buffer element recoil spring **125**, the  
20 rearward movement of the collar **170** compress the buffer element recoil spring **125**.

**[00155]** Each of the buffer element recoil spring **125**, the buffer element **130**, the weight **150** (if included), the bumper **160**, the collar **170**, and the sleeve **180** contributes to the reciprocating mass, or "dead blow" effect  
25 provided by the buffer assembly **100**.

**[00156]** As illustrated most clearly in **Figs. 46-47**, the recoil management system **100** is illustrated as being utilized in conjunction with a lower receiver **10** and, further, being threadedly connected to the lower receiver **10** via interaction of an externally threaded portion **111** of the buffer tube **110** and  
30 an internally threaded buffer tube receiving aperture **11** of the lower receiver **10**. It should be appreciated that the lower receiver **10** can be a typical lower receiver for a firearm. It should also be appreciated that a more

detailed explanation of the lower receiver **10**, the standard features and elements of a receiver that are not related to the present disclosure, instructions regarding how to assemble the lower receiver **10**, and certain other items and/or techniques necessary for the implementation and/or operation of the various exemplary embodiments of the present disclosure are not provided herein because such elements are commercially available and/or such background information will be known to one of ordinary skill in the art. Therefore, it is believed that the level of description provided herein is sufficient to enable one of ordinary skill in the art to understand and practice the present disclosure, as described.

**[00157]** **FIG. 48** illustrates a left side, cross-sectional view of an exemplary embodiment of an assembled, recoil management system, according to the presently disclosed systems, methods, and/or apparatuses. As illustrated in **FIG. 48**, the sleeve **180** has been removed from the recoil management system.

**[00158]** As illustrated in **FIG. 48**, a washer **198** may optionally be positioned between the buffer element recoil spring and the retaining pin **195**. However, the washer **198** is optional and, in certain exemplary embodiments, one or more portions of the first end **127** of the buffer element recoil spring **125** contact the retaining pin **195** to maintain the first end **127** of the buffer element recoil spring **125** in position.

**[00159]** **Figs. 49-51** illustrate various components and/or elements of an exemplary embodiment of a buffer element, according to the presently disclosed systems, methods, and/or apparatuses. As illustrated in **FIG. 49**, the optional first buffer element chamfer **133** is more radiused, rounded, or arcuate so as to provide a radiused or substantially radiused transitional surface between the buffer element knob **137** and the first end **131** of the buffer element **130**.

**[00160]** It should be appreciated that the more rounded or arcuate first buffer element chamfer **133** may be formed at any desired radius, arc, or angle, so as to provide a transition surface between the buffer element knob **137** and the first end **131** of the buffer element **130**.

**[00161]** In certain exemplary embodiments, the more rounded or arcuate first buffer element chamfer **133** may be formed so as to provide a transition surface between the second buffer element chamfer **136** and the first end **131** of the buffer element **130**.

5 **[00162]** As further illustrated in **Figs. 49-51**, an externally threaded portion **134** is formed in a portion of the buffer element body portion **135**, extending from the second end **132** of the buffer element **130**. An internally threaded portion **189** is formed in a portion of the sleeve spring recess **185** of the sleeve **180**.

10 **[00163]** In these exemplary embodiments, the interaction of the externally threaded portion **134** and the internally threaded portion **189** allows the buffer element body portion **135** to be threadedly attached or connected to the sleeve **180**.

**[00164]** While the buffer element **130** has been illustrated as being  
15 attached, coupled, or connected to the sleeve **180** by a retaining pin **195** or interaction of the externally threaded portion **134** and the internally threaded portion **189**, it should be appreciated that the buffer element **130** may be pinned, threadedly attached or coupled, attached or coupled through interaction of one or more lugs and corresponding recesses, attached or  
20 coupled by an adhesive, welded, and/or bonded to the sleeve **180**. Thus, it should be understood that the buffer element **130** may be attached, coupled, or connected to the sleeve **180** in any desired manner.

**[00165]** While the presently disclosed systems, methods, and/or  
apparatuses have been described in conjunction with the exemplary  
25 embodiments outlined above, the foregoing description of exemplary embodiments of the present disclosure, as set forth above, are intended to be illustrative, not limiting and the fundamental systems, methods, and/or apparatuses should not be considered to be necessarily so constrained. It is evident that the systems, methods, and/or apparatuses are not limited to the  
30 particular variation or variations set forth and many alternatives, adaptations modifications, and/or variations will be apparent to those skilled in the art.

**[00166]** Furthermore, where a range of values is provided, it is understood that every intervening value, between the upper and lower limit of that range and any other stated or intervening value in that stated range is encompassed within the presently disclosed systems, methods, and/or apparatuses. The upper and lower limits of these smaller ranges may independently be included in the smaller ranges and is also encompassed within the present disclosure, subject to any specifically excluded limit in the stated range. Where the stated range includes one or both of the limits, ranges excluding either or both of those included limits are also included in the present disclosure.

**[00167]** It is to be understood that the phraseology of terminology employed herein is for the purpose of description and not of limitation. Unless defined otherwise, all technical and scientific terms used herein have the same meaning as commonly understood by one of ordinary skill in the art to which the presently disclosed systems, methods, and/or apparatuses belong.

**[00168]** In addition, it is contemplated that any optional feature of the inventive variations described herein may be set forth and claimed independently, or in combination with any one or more of the features described herein.

**[00169]** Accordingly, the foregoing description of exemplary embodiments will reveal the general nature of the presently disclosed systems, methods, and/or apparatuses, such that others may, by applying current knowledge, change, vary, modify, and/or adapt these exemplary, non-limiting embodiments for various applications without departing from the spirit and scope of the present disclosure and elements or methods similar or equivalent to those described herein can be used in practicing the present disclosure. Any and all such changes, variations, modifications, and/or adaptations should and are intended to be comprehended within the meaning and range of equivalents of the disclosed exemplary embodiments and may be substituted without departing from the true spirit and scope of the presently disclosed systems, methods, and/or apparatuses.

**[00170]** Also, it is noted that as used herein and in the appended claims, the singular forms “a”, “and”, “said”, and “the” include plural referents unless the context clearly dictates otherwise. Conversely, it is contemplated that the claims may be so-drafted to require singular elements or exclude any optional element indicated to be so here in the text or drawings. This statement is intended to serve as antecedent basis for use of such exclusive terminology as “solely”, “only”, and the like in connection with the recitation of claim elements or the use of a “negative” claim limitation(s).

**WHAT IS CLAIMED IS:**

- 1           1.     A recoil management system, comprising:  
2                 a buffer tube, wherein said buffer tube extends, along a  
3 longitudinal axis, from a first end to a second end and having an internal  
4 buffer tube cavity defined by an open end, one or more side walls, and a  
5 bottom wall;  
6                 a buffer tube recoil spring;  
7                 a buffer element, wherein said buffer element comprises an  
8 elongate buffer element body portion extending from a buffer element knob,  
9 wherein said buffer element comprises a buffer element cavity defined by an  
10 open end, one or more side walls, and a bottom wall;  
11                 a collar, wherein a collar aperture is formed through said collar,  
12 along a longitudinal axis of said collar, wherein a collar recess extends from  
13 a first end of said collar and is defined by one or more side walls and a collar  
14 recess shoulder;  
15                 a sleeve, wherein a sleeve aperture is formed through said sleeve,  
16 along a longitudinal axis of said sleeve, wherein said sleeve aperture is  
17 formed so as to accept at least a portion of said bumper therein, wherein a  
18 sleeve recess extends from a first end of said sleeve and is defined by one  
19 or more side walls and a sleeve recess shoulder, wherein said sleeve recess  
20 is formed so as to accept at least a portion of said buffer element body  
21 portion therein;  
22                 a buffer element recoil spring, wherein said buffer element recoil  
23 spring is positioned about at least a portion of said elongate buffer element  
24 body portion, between said collar and said sleeve; and  
25                 a bumper, wherein a bumper extension portion extends from a first  
26 end of said bumper to a bumper shoulder, wherein said bumper extension  
27 portion is such that at least a portion of said bumper extension portion can  
28 be fitted at least partially within said sleeve aperture.

1           2.     The recoil management system of claim 1, wherein said collar  
2 recess is formed so as to accept at least a portion of said buffer element  
3 knob at least partially therein.

1           3.     The recoil management system of claim 1, wherein said collar  
2 aperture has a diameter that is less than a diameter of said collar recess and  
3 allows said buffer element body portion to be slidable within said collar  
4 aperture.

1           4.     The recoil management system of claim 1, wherein said buffer  
2 element recoil spring has a spring rate or spring biasing force that is less  
3 than, equal to, or greater than a spring rate or spring biasing force of said  
4 buffer tube recoil spring.

1           5.     The recoil management system of claim 1, wherein said sleeve  
2 comprises a buffer element retaining pin aperture that extends at least  
3 partially through said sleeve and is formed so as to accept at least a portion  
4 of a retaining pin therethrough.

1           6.     The recoil management system of claim 1, further comprising:  
2                 a weight, wherein said weight is positioned within said buffer  
3 element cavity and wherein said weight comprises a solid portion of material,  
4 a powdered or granulated material, or a liquid.

1           7.     The recoil management system of claim 1, wherein when said  
2 buffer element is in a compressed position, at least a portion of said buffer  
3 element knob extends at least partially into an inside diameter of a bolt  
4 carrier.

1           8.     The recoil management system of claim 1, wherein when said  
2 buffer element is in a compressed position, at least a portion of said buffer  
3 element knob extends from said collar.

1           9.     The recoil management system of claim 1, further comprising:  
2                 a bumper retaining aperture that extends at least partially through  
3 said bumper extension portion and is formed so as to accept at least a  
4 portion of a retaining pin therethrough.

1           10.    The recoil management system of claim 1, wherein said buffer  
2 element recoil spring has an external diameter that is less than an internal  
3 diameter of said buffer tube recoil spring.

1           11.    The recoil management system of claim 1, wherein a chamfer  
2 is formed as a transitional between said buffer element body portion and  
3 said buffer element knob.

1           12.    The recoil management system of claim 1, wherein a chamfer  
2 is formed as a transitional between said first end of said buffer element body  
3 portion and said buffer element knob.

1           13.    The recoil management system of claim 1, further comprising:  
2           a sleeve retaining pin aperture that extends at least from an outer  
3 surface of said sleeve body into said sleeve aperture.

1           14.    A recoil management system, comprising:

2           a buffer element, wherein said buffer element extends from a  
3 buffer element knob, wherein said buffer element comprises a buffer  
4 element cavity defined by an open end, one or more side walls, and a  
5 bottom wall;

6           a collar, wherein a collar aperture is formed through said collar,  
7 along a longitudinal axis of said collar, wherein a collar recess extends from  
8 a first end of said collar and is defined by one or more side walls and a collar  
9 recess shoulder;

10          a sleeve, wherein a sleeve aperture is formed through said sleeve,  
11 along a longitudinal axis of said sleeve, wherein said sleeve aperture is  
12 formed so as to accept at least a portion of said bumper therein, wherein a  
13 sleeve recess extends from a first end of said sleeve and is defined by one  
14 or more side walls and a sleeve recess shoulder, wherein said sleeve recess  
15 is formed so as to accept at least a portion of said buffer element body  
16 portion therein;

17          a buffer element recoil spring, wherein said buffer element recoil  
18 spring is positioned about at least a portion of said elongate buffer element  
19 body portion, between said collar and said sleeve; and

20          a bumper, wherein a bumper extension portion extends from a first  
21 end of said bumper to a bumper shoulder, wherein said bumper extension  
22 portion is such that at least a portion of said bumper extension portion can  
23 be fitted at least partially within said sleeve aperture.

1           15.    The recoil management system of claim 14, wherein said collar  
2 recess is formed so as to accept at least a portion of said buffer element  
3 knob at least partially therein.

1           16.    The recoil management system of claim 14, wherein said collar  
2 aperture has a diameter that is less than a diameter of said collar recess and  
3 allows said buffer element body portion to be slidable within said collar  
4 aperture.

1           17.    The recoil management system of claim 14, further comprising:  
2           a weight, wherein said weight is positioned within said buffer  
3 element cavity and wherein said weight comprises a solid portion of material,  
4 a powdered or granulated material, or a liquid.

1           18.    The recoil management system of claim 14, wherein when said  
2 buffer element is in a compressed position, at least a portion of said buffer  
3 element knob extends at least partially into an inside diameter of a bolt  
4 carrier.

1           19.    The recoil management system of claim 14, wherein when said  
2 buffer element is in a compressed position, at least a portion of said buffer  
3 element knob extends from said collar.

1           20.    A recoil management system, comprising:

2           a buffer element, wherein said buffer element extends from an  
3 elongate buffer element body portion to a buffer element knob, wherein said  
4 buffer element comprises a buffer element cavity defined by an open end,  
5 one or more side walls, and a bottom wall;

6           a collar, wherein a collar aperture is formed through said collar,  
7 along a longitudinal axis of said collar, wherein a collar recess extends from  
8 a first end of said collar and is defined by one or more side walls and a collar  
9 recess shoulder;

10          a sleeve, wherein a sleeve aperture is formed through said sleeve,  
11 along a longitudinal axis of said sleeve, wherein a sleeve recess extends  
12 from a first end of said sleeve and is defined by one or more side walls and a  
13 sleeve recess shoulder, wherein said sleeve recess is formed so as to  
14 accept at least a portion of said buffer element body portion therein;

15          a buffer element recoil spring, wherein said buffer element recoil

16 spring is positioned about at least a portion of said elongate buffer element  
17 body portion, between said collar and said sleeve; and

18 a bumper, wherein a bumper extension portion extends from a first  
19 end of said bumper to a bumper shoulder, wherein said bumper extension  
20 portion is such that at least a portion of said bumper extension portion can  
21 be fitted at least partially within said sleeve aperture.

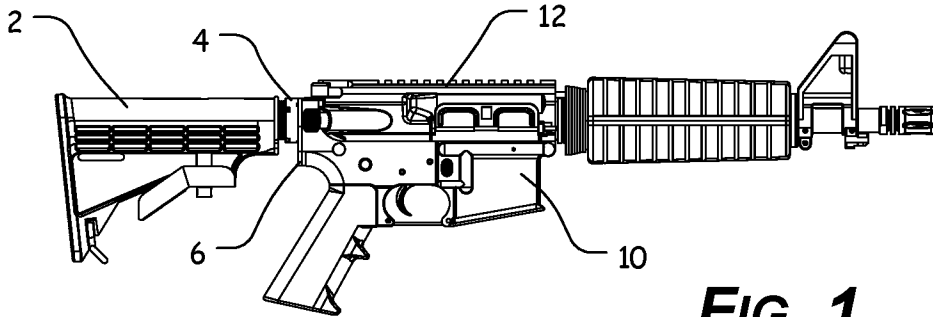
1 21. A recoil management system, comprising:

2 a buffer element, wherein said buffer element extends from an  
3 elongate buffer element body portion to a buffer element knob, wherein said  
4 buffer element comprises a buffer element cavity defined by an open end,  
5 one or more side walls, and a bottom wall;

6 a collar, wherein a collar aperture is formed through said collar,  
7 along a longitudinal axis of said collar;

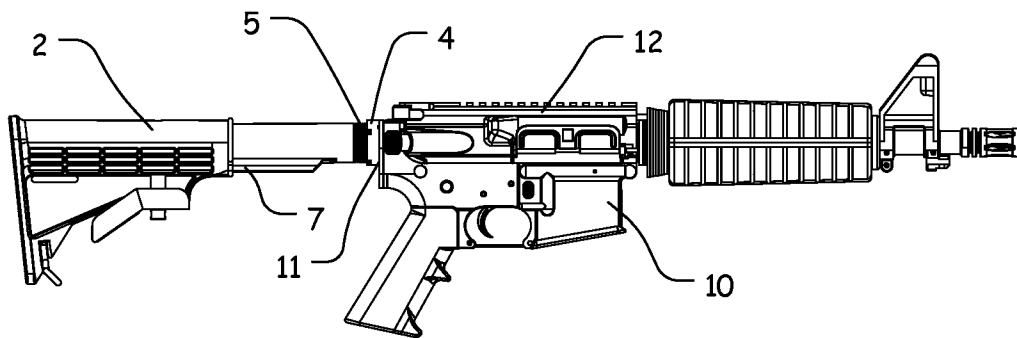
8 a bumper, wherein said bumper is attached or coupled to said  
9 buffer element, proximate an end of said elongate buffer element body  
10 portion; and

11 a buffer element recoil spring, wherein said buffer element recoil  
12 spring is positioned about at least a portion of said elongate buffer element  
13 body portion, between said collar and said bumper.



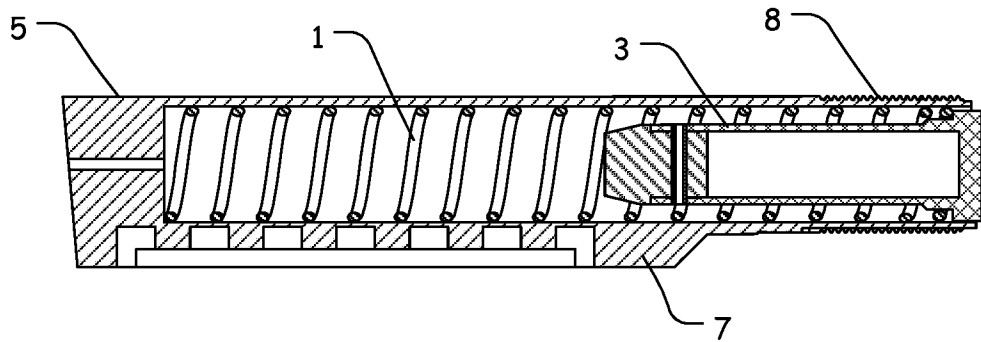
**FIG. 1**

**PRIOR ART**



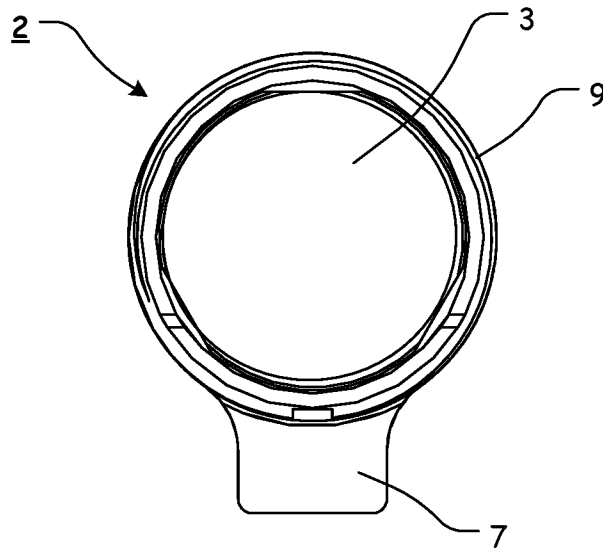
**FIG. 2**

**PRIOR ART**



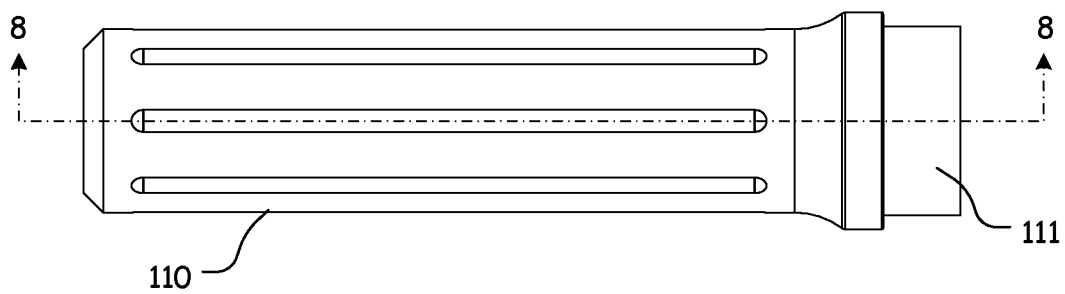
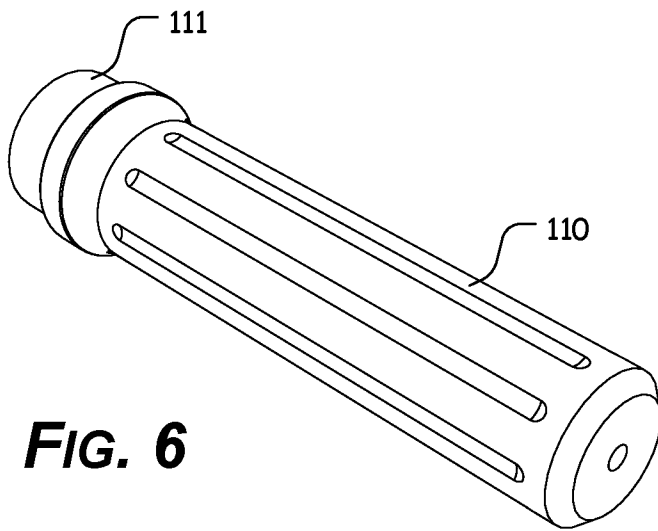
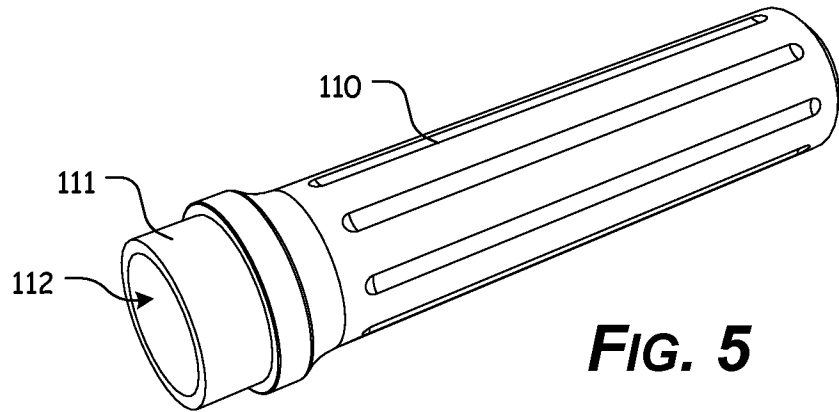
**FIG. 3**

**PRIOR ART**

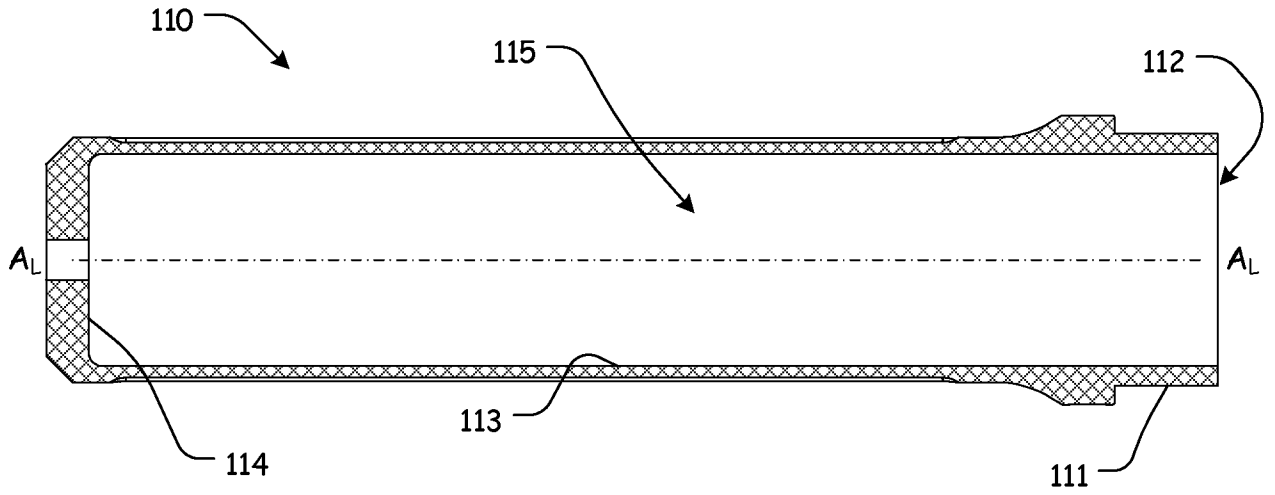


**FIG. 4**

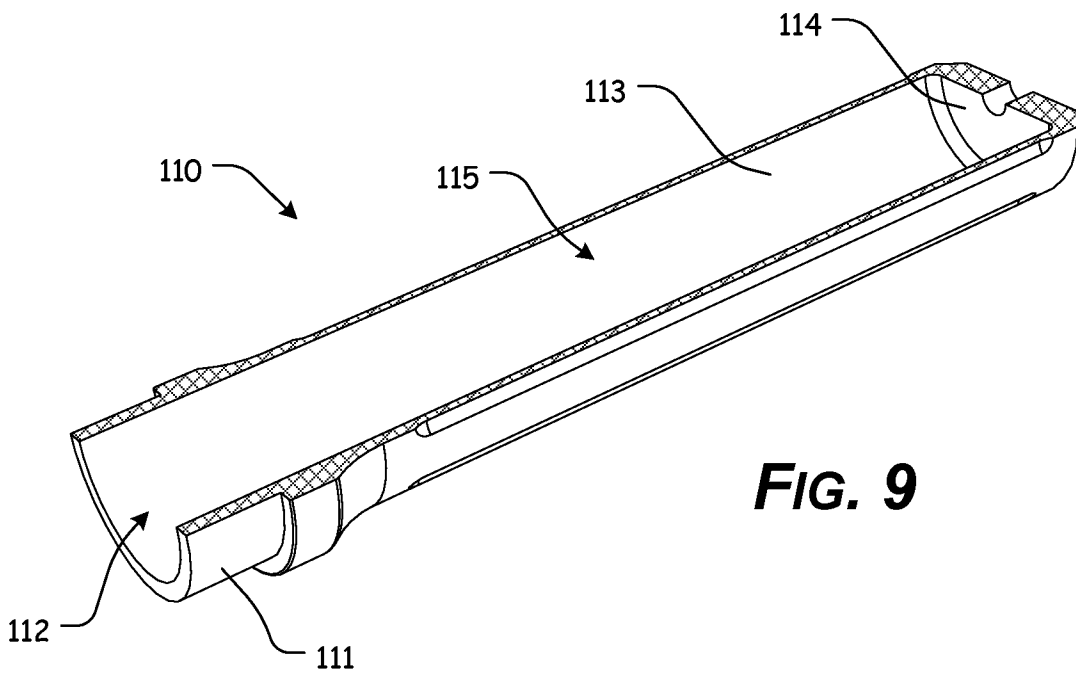
**PRIOR ART**



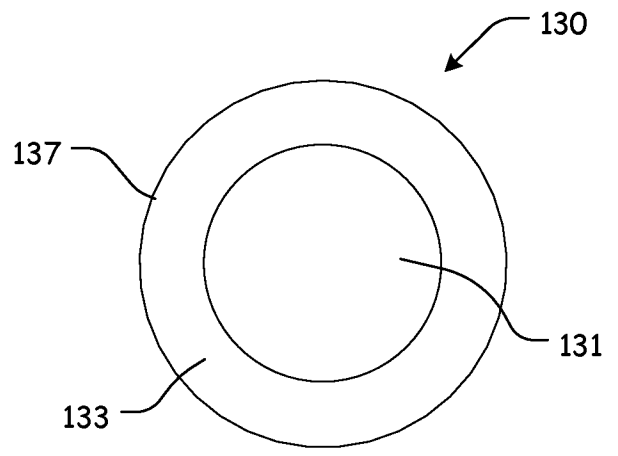
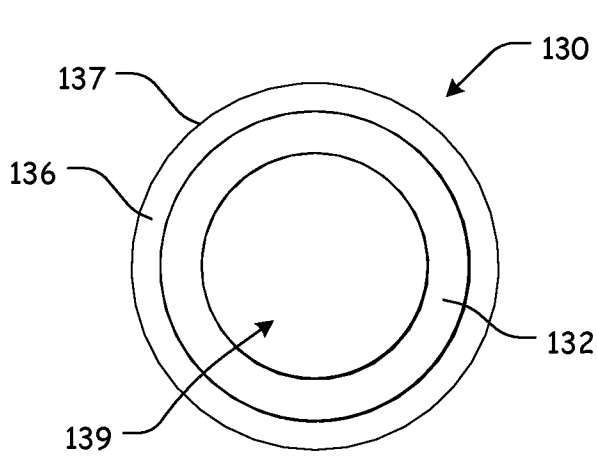
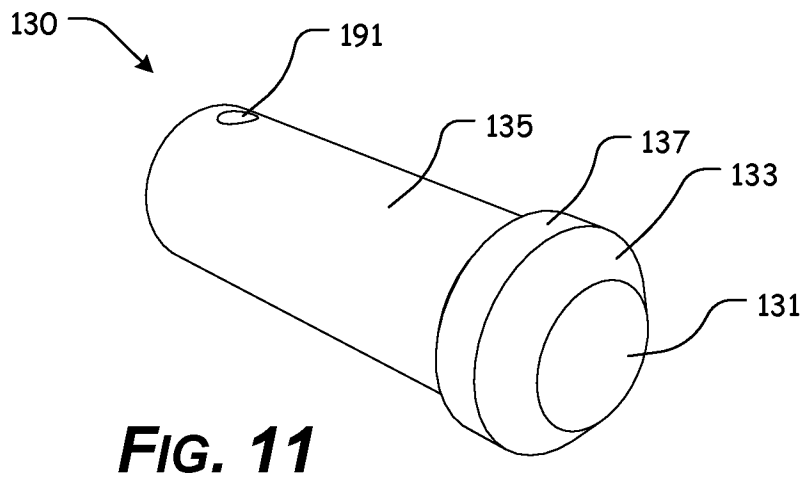
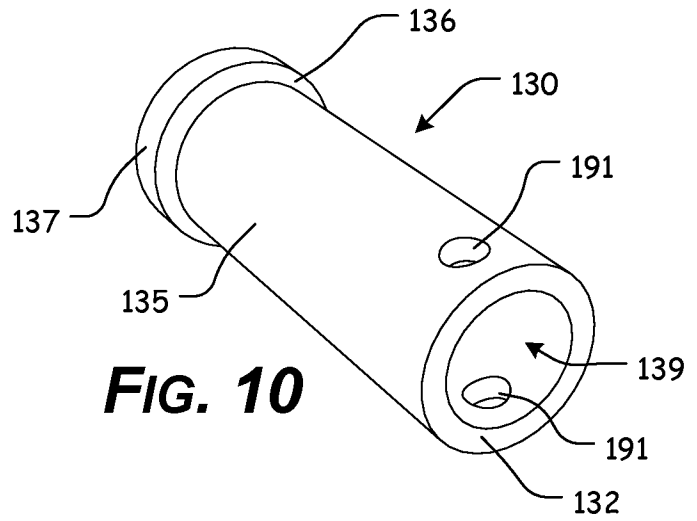
**FIG. 7**

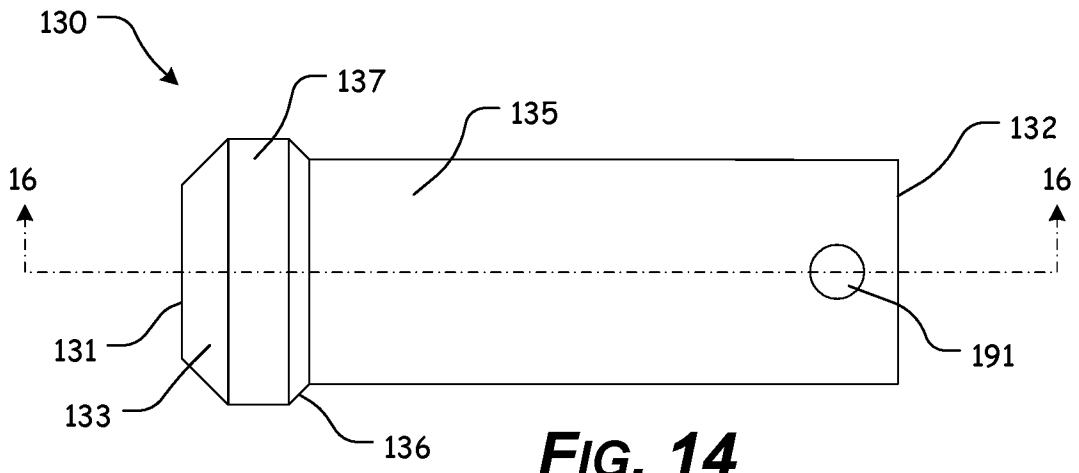


**FIG. 8**

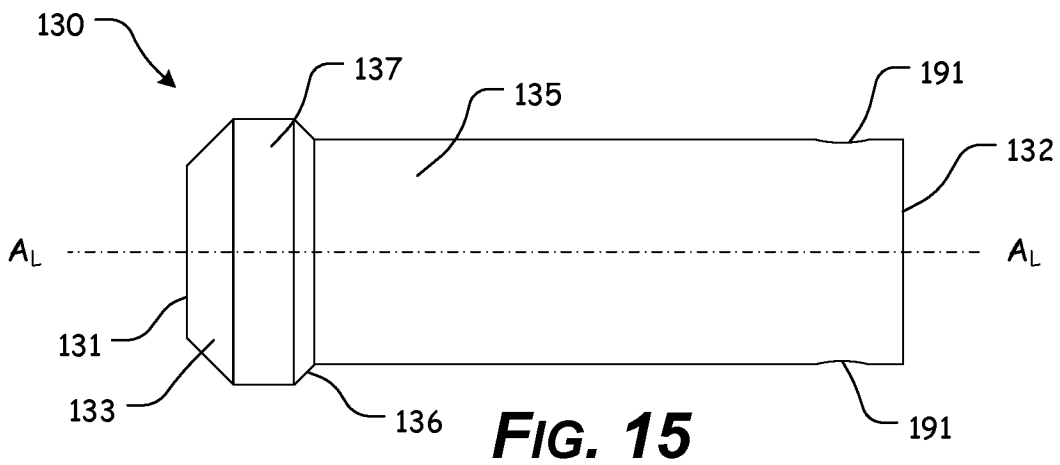


**FIG. 9**

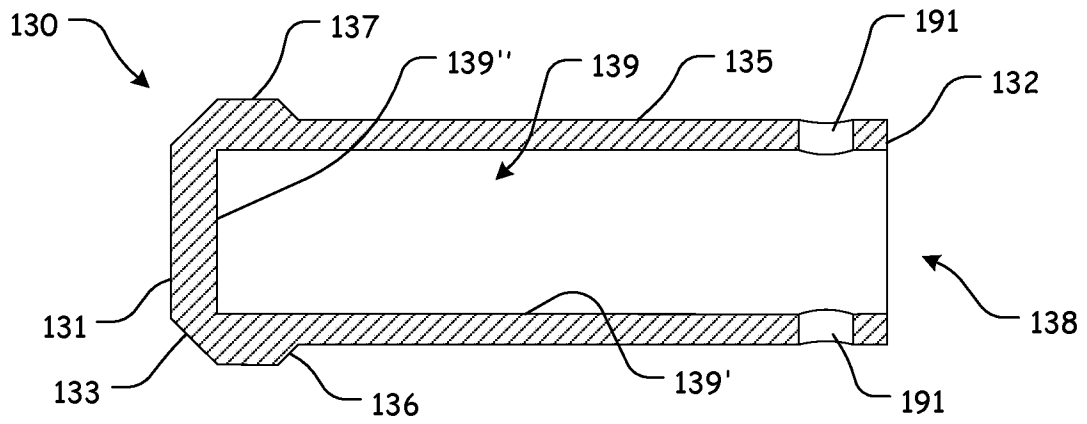




**FIG. 14**

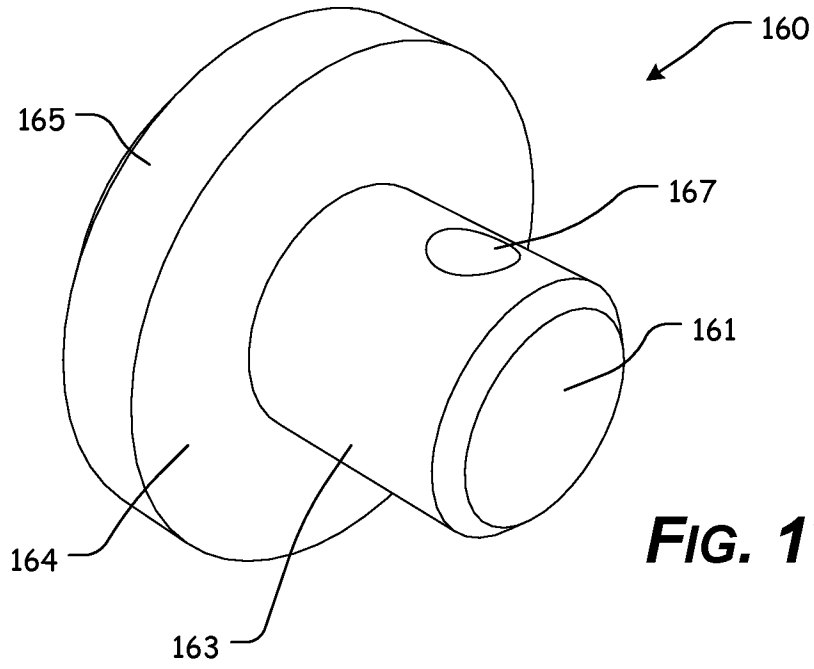


**FIG. 15**

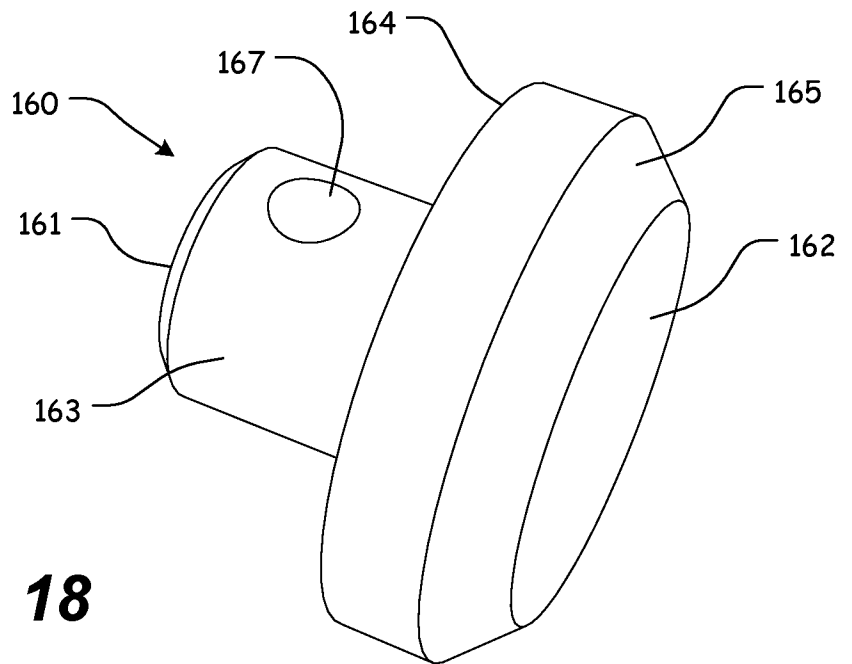


**FIG. 16**

7/21

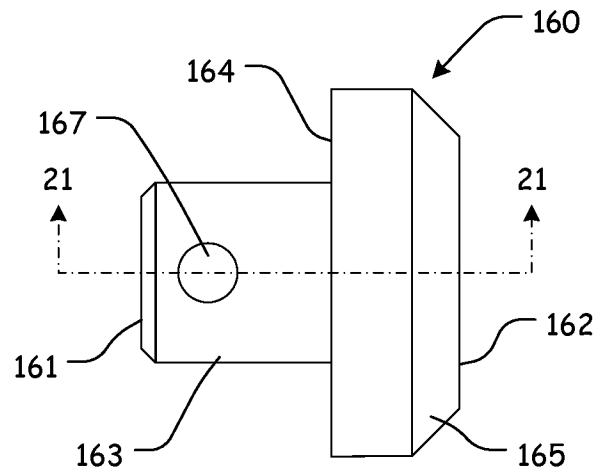


**FIG. 17**

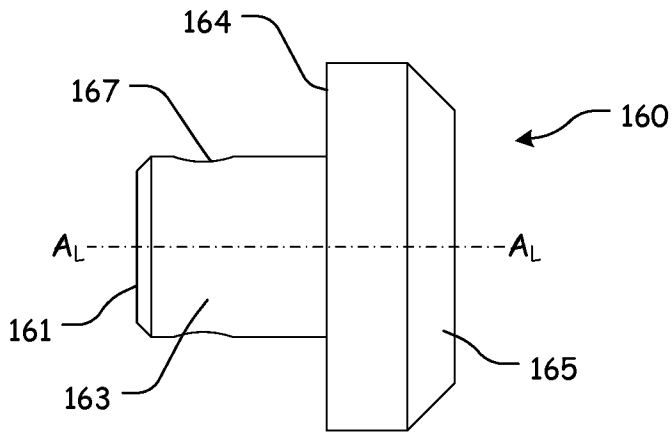


**FIG. 18**

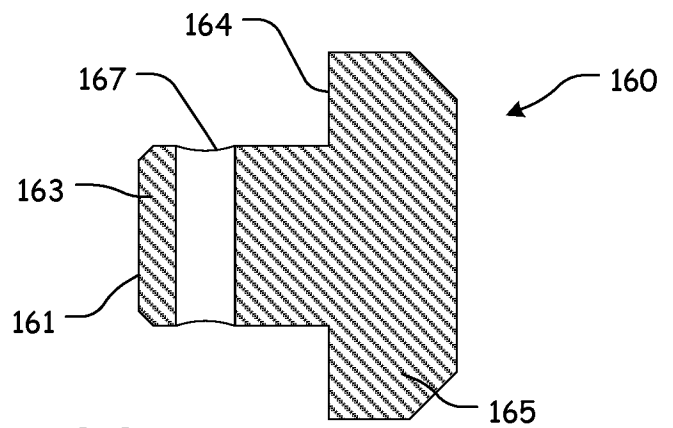
8/21



**FIG. 19**

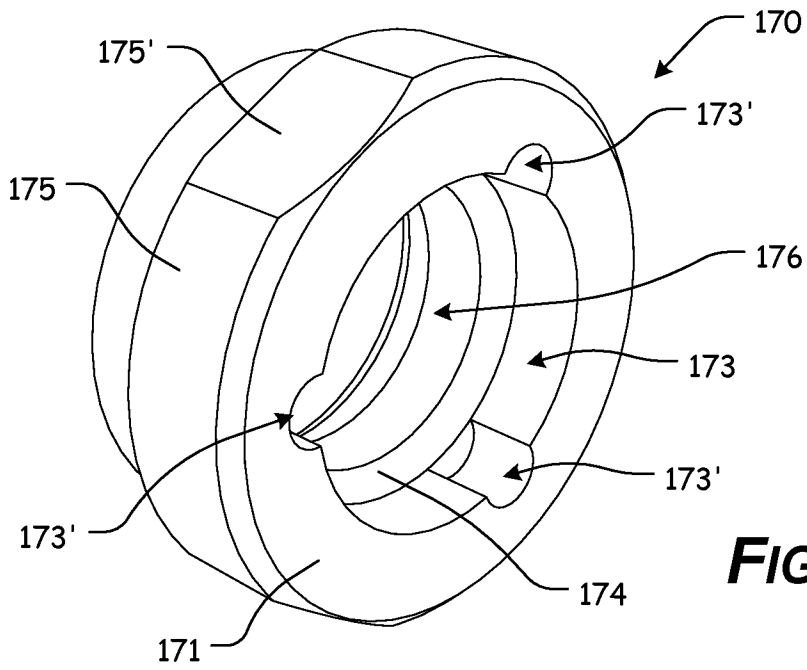


**FIG. 20**

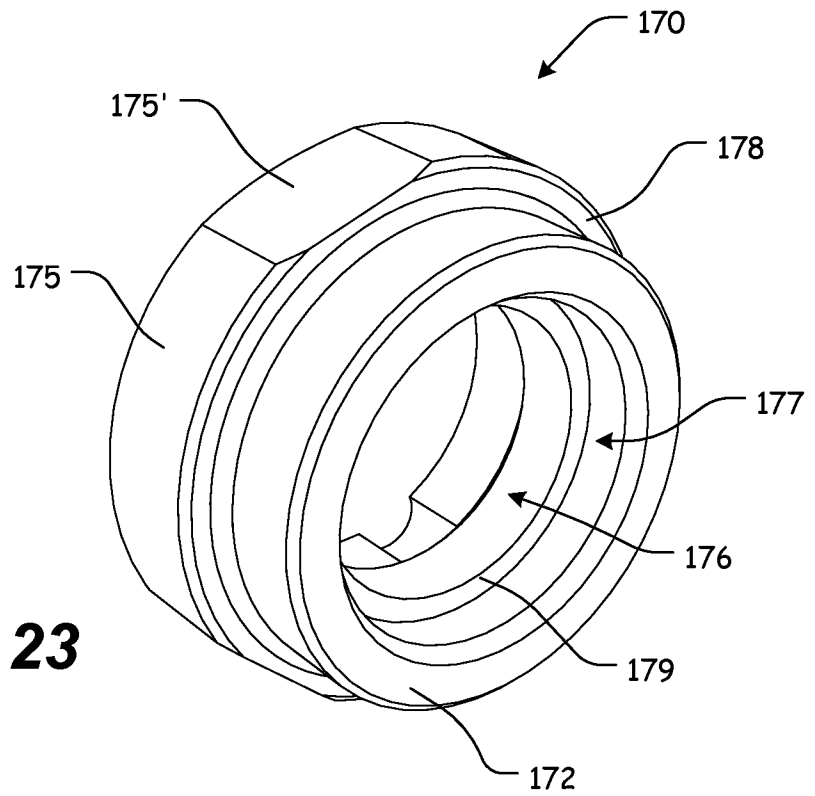


**FIG. 21**

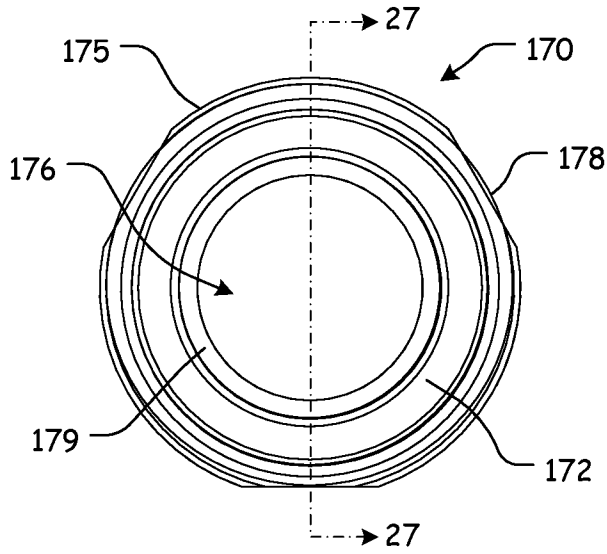
9/21



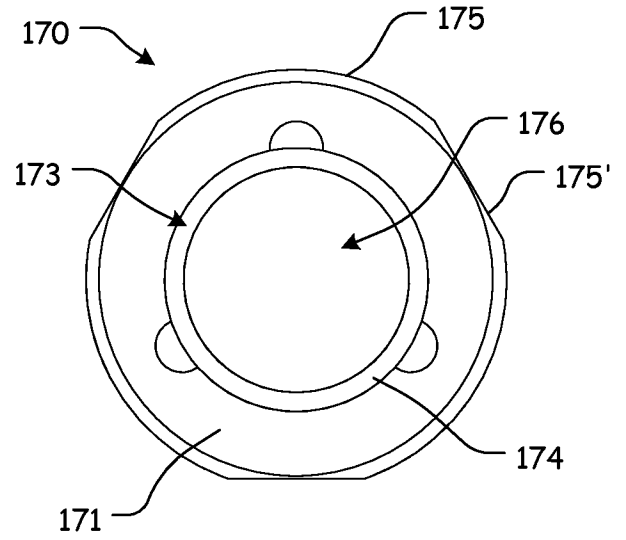
**FIG. 22**



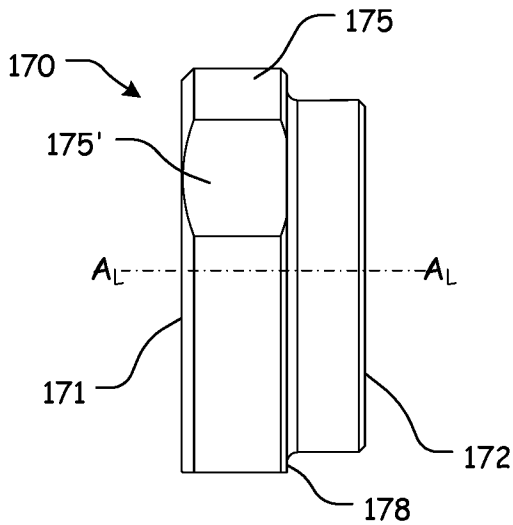
**FIG. 23**



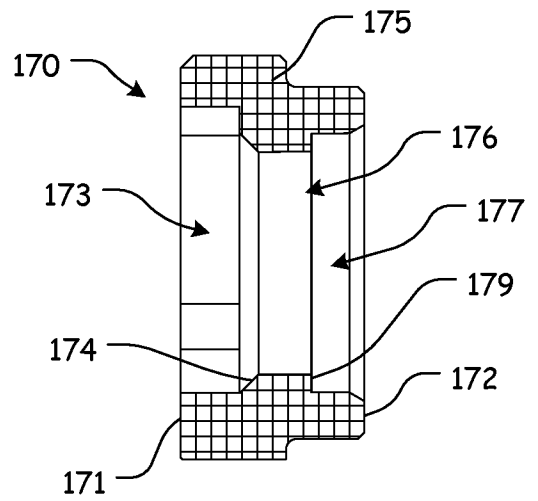
**FIG. 24**



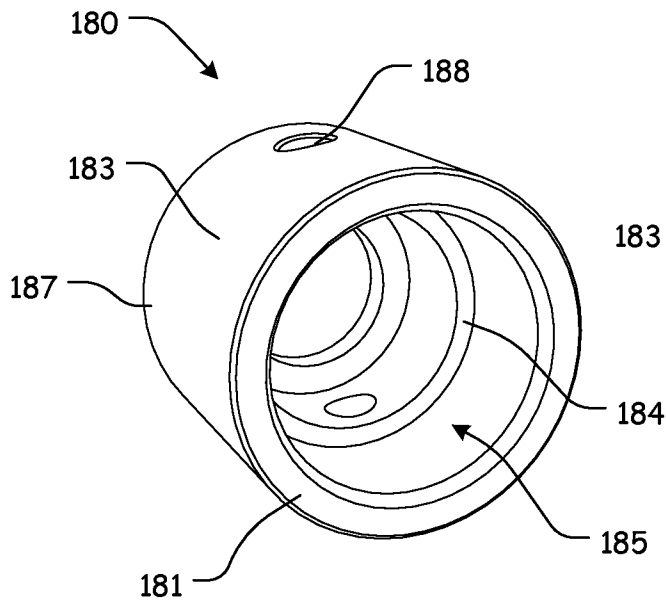
**FIG. 25**



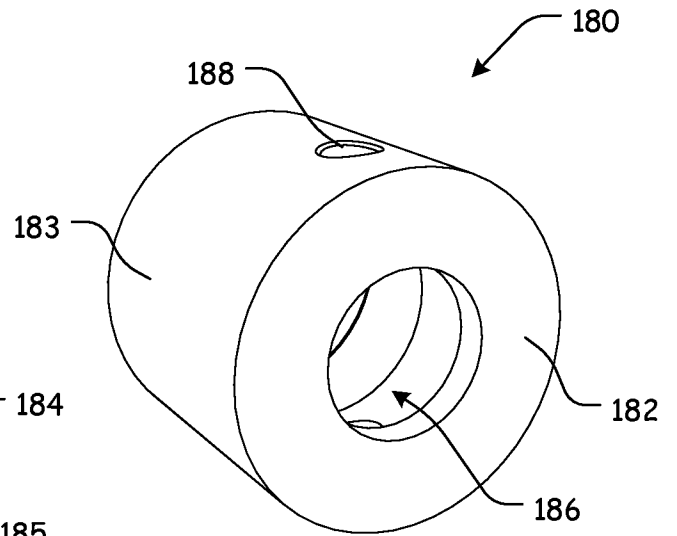
**FIG. 26**



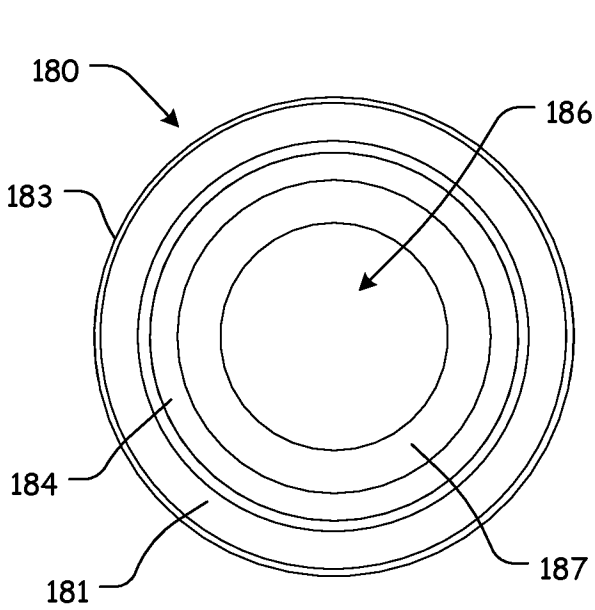
**FIG. 27**



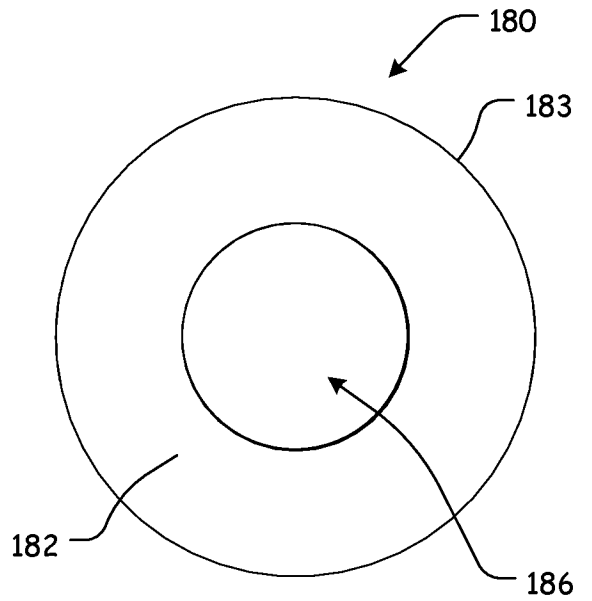
**FIG. 28**



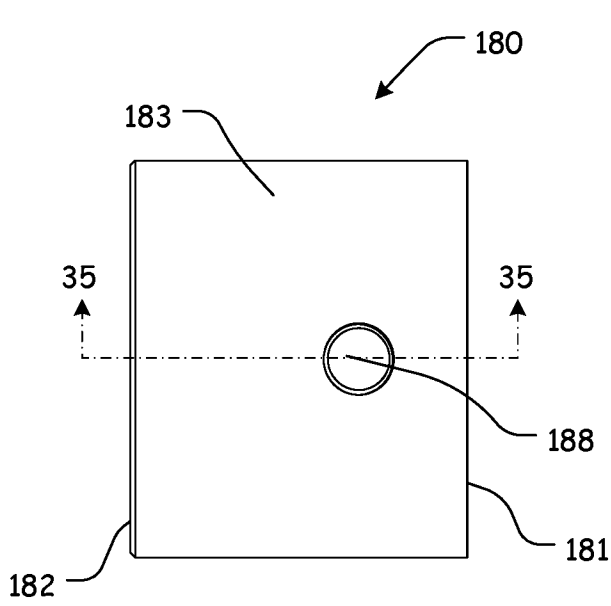
**FIG. 29**



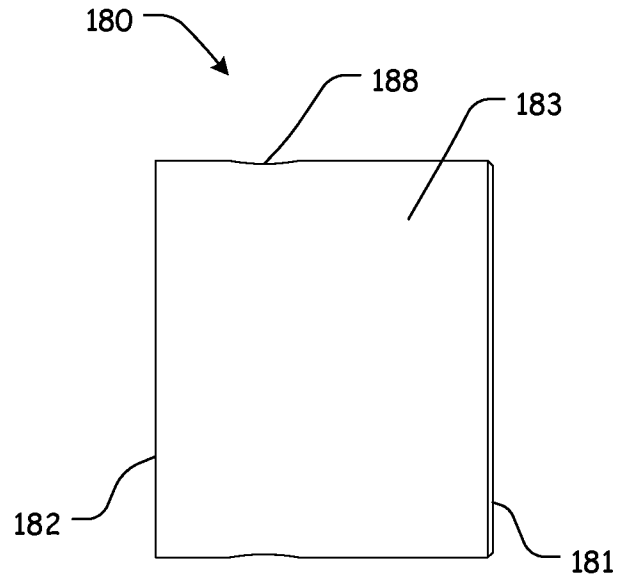
**FIG. 30**



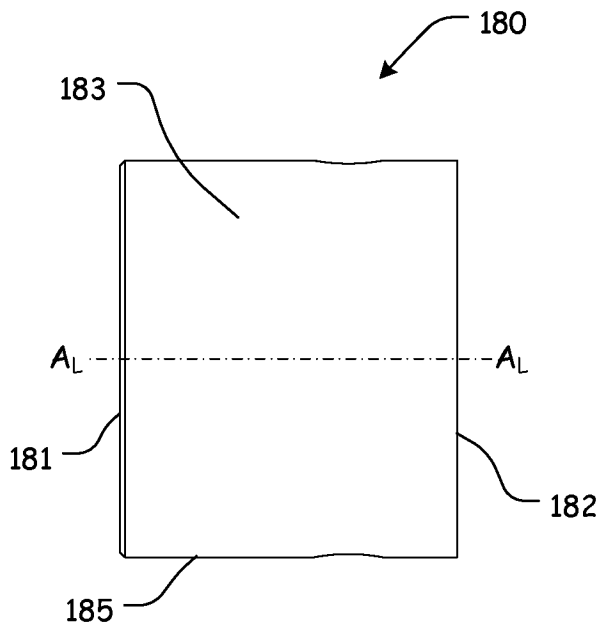
**FIG. 31**



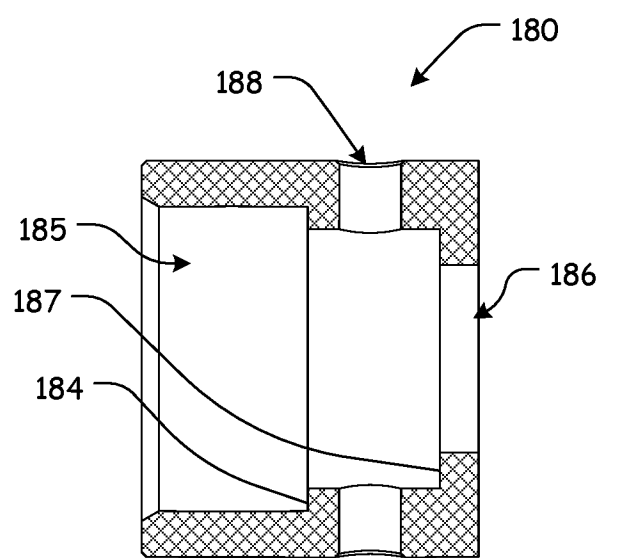
**FIG. 32**



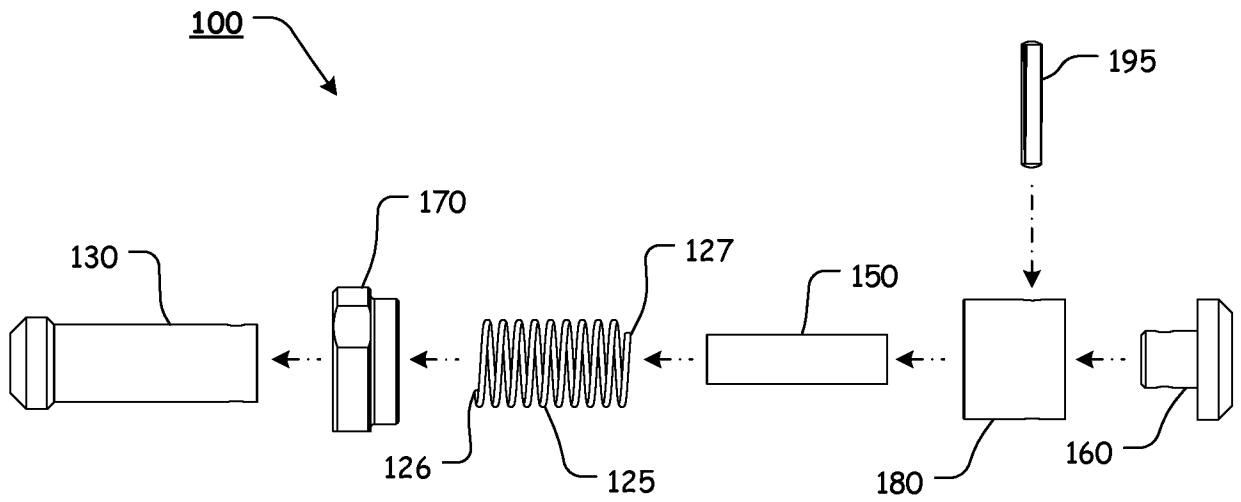
**FIG. 33**



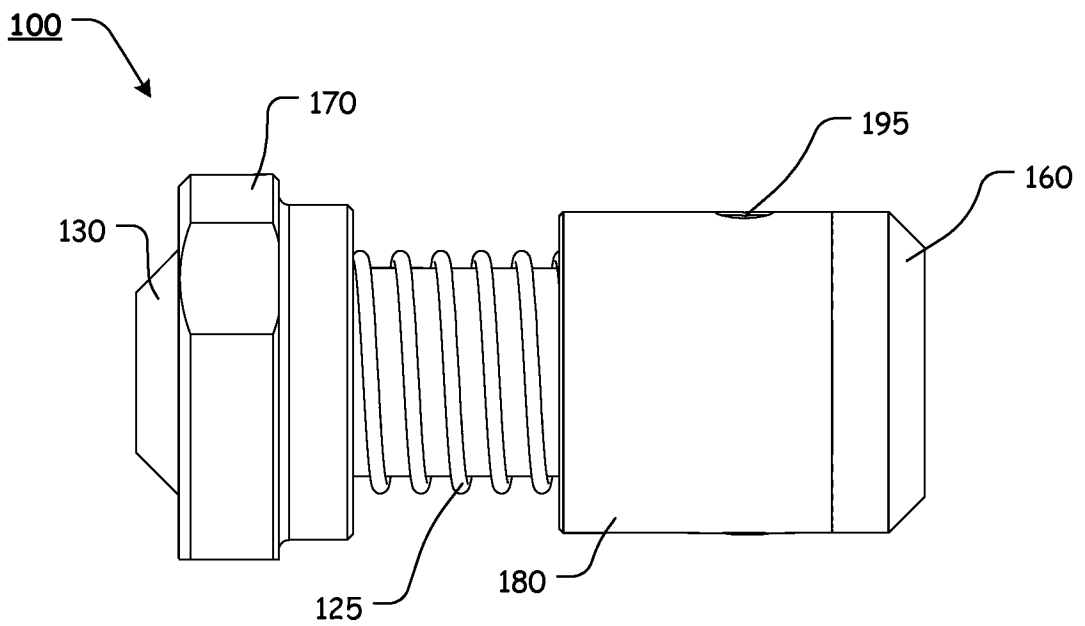
**FIG. 34**



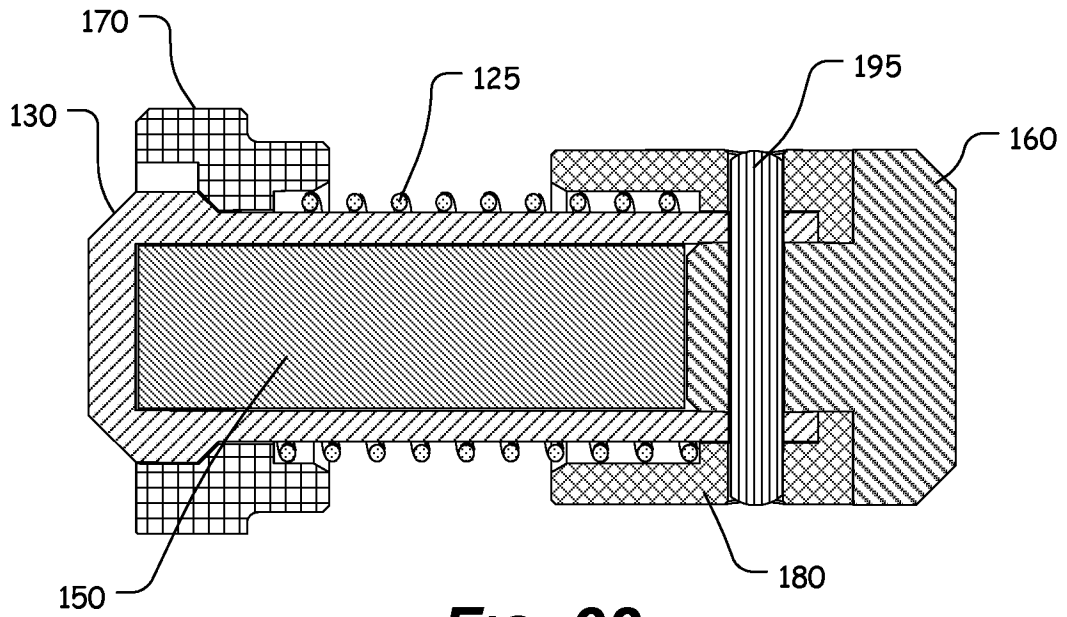
**FIG. 35**



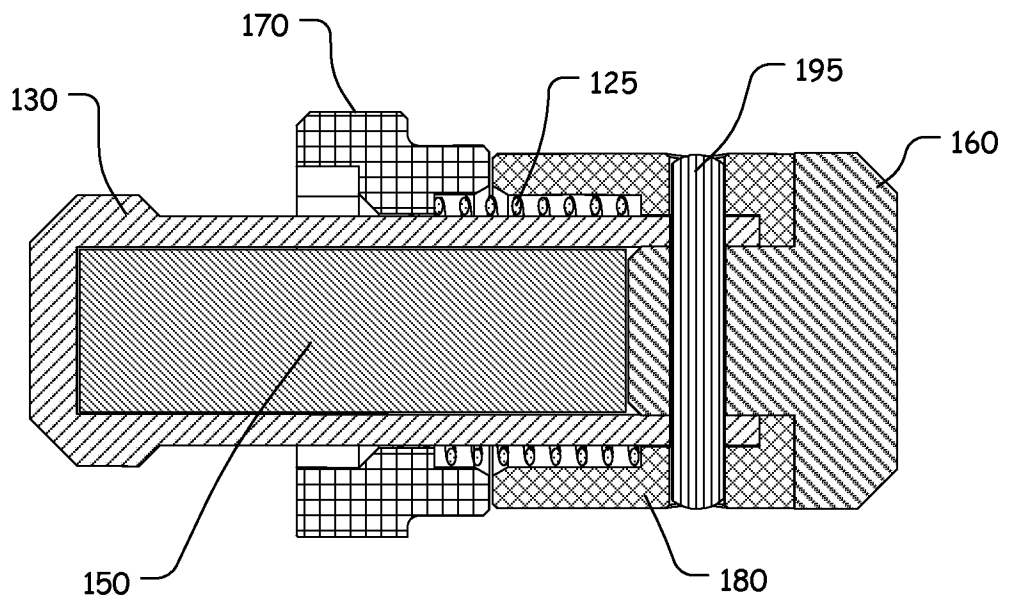
**FIG. 36**



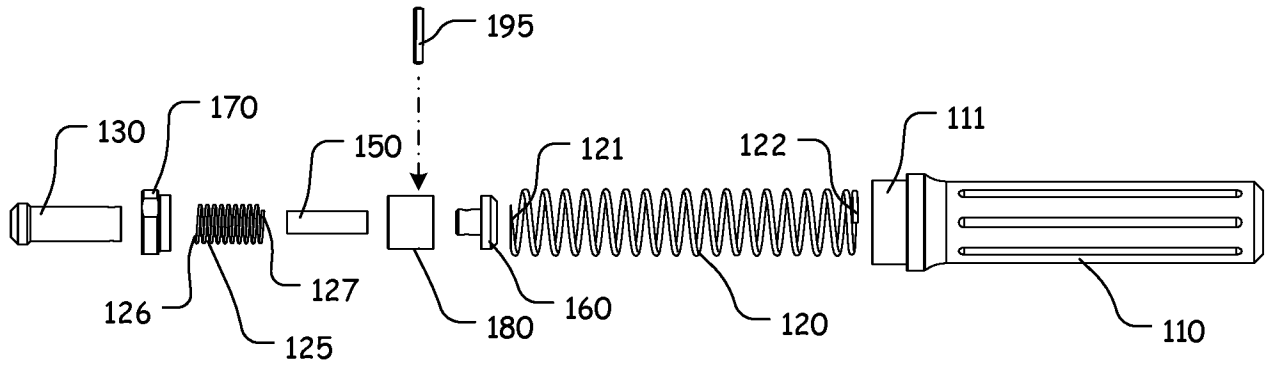
**FIG. 37**



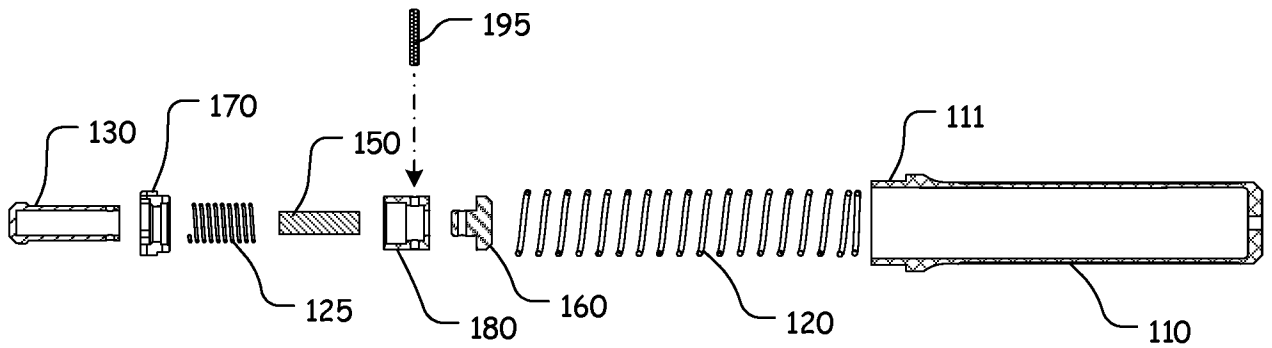
**FIG. 38**



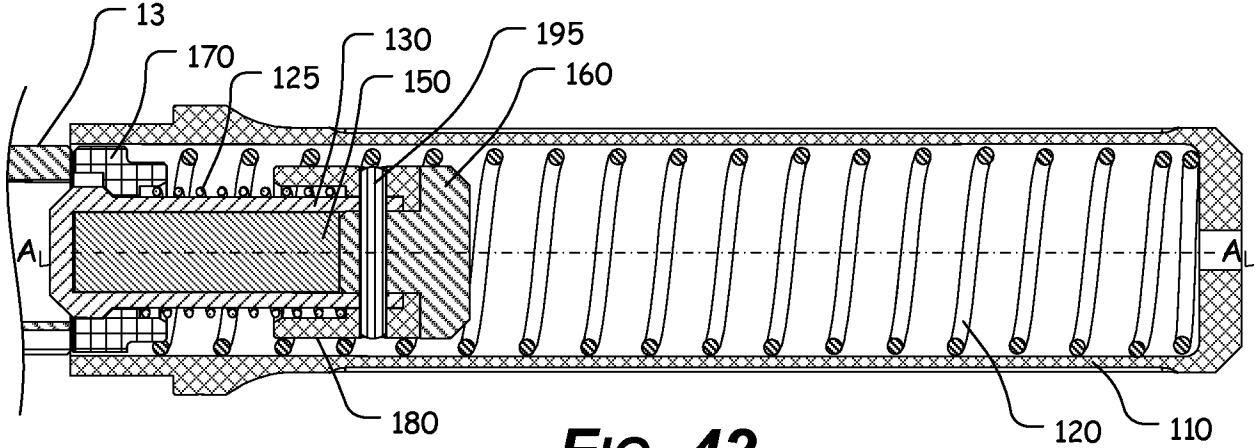
**FIG. 39**



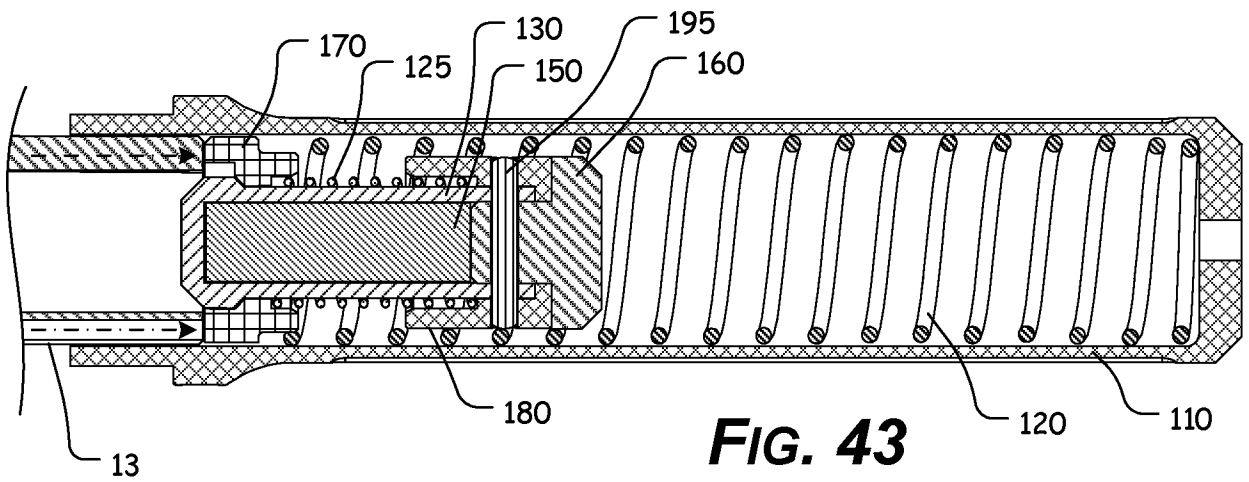
**FIG. 40**



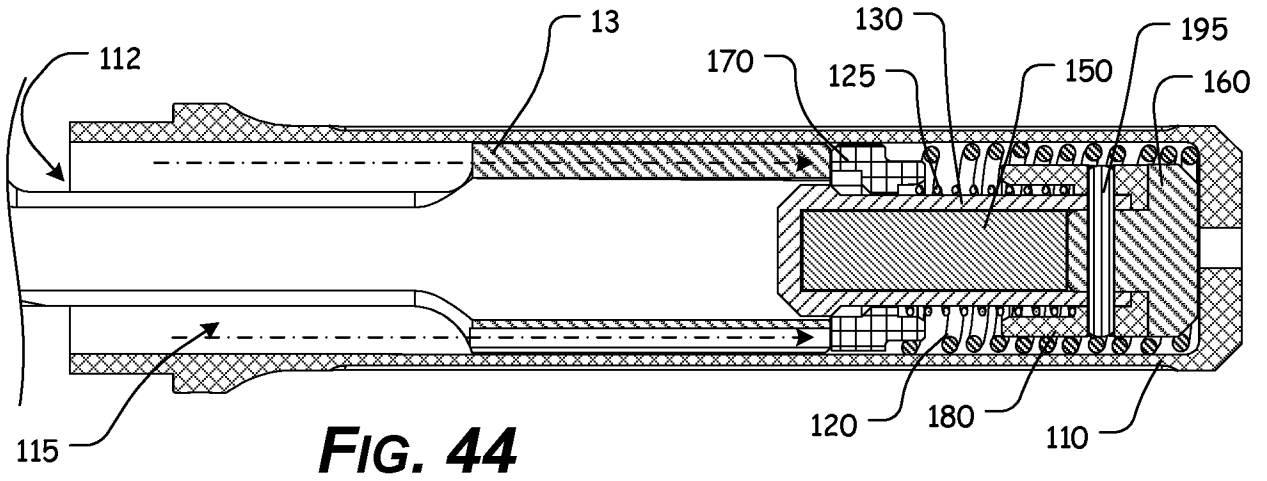
**FIG. 41**



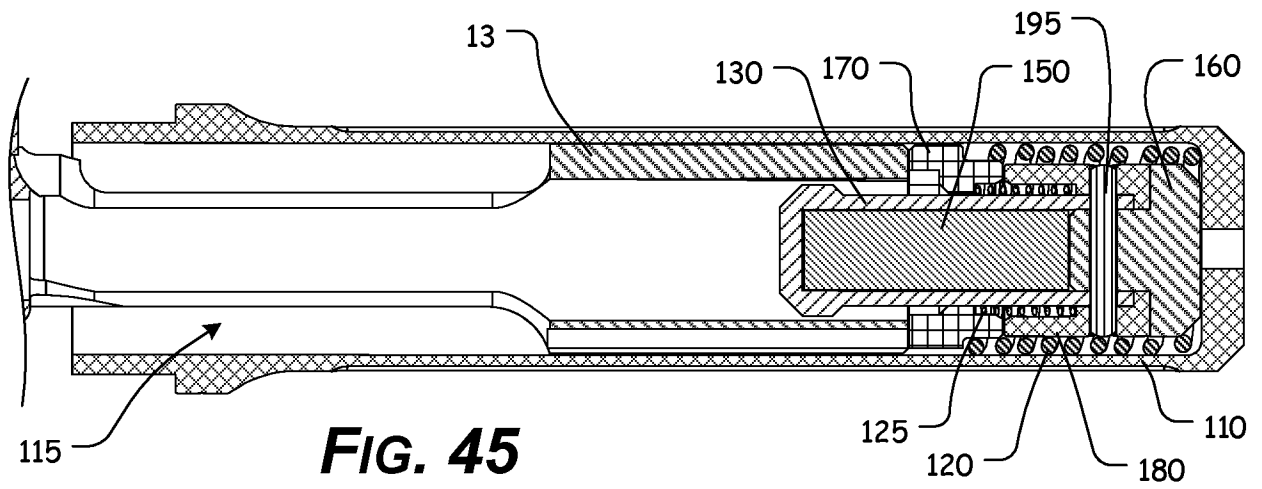
**FIG. 42**



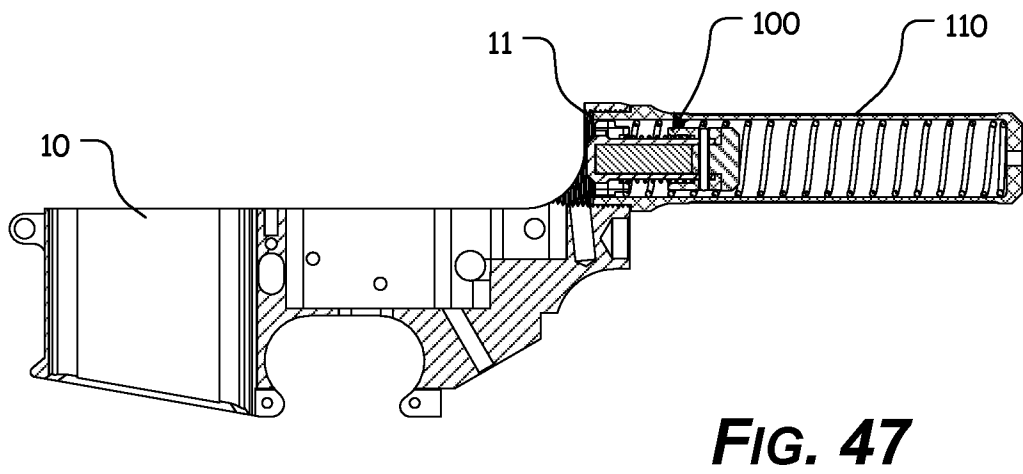
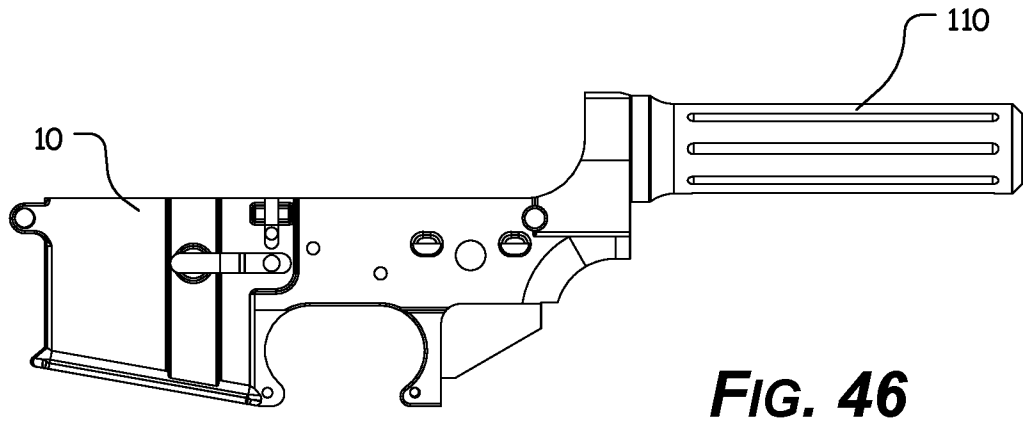
**FIG. 43**

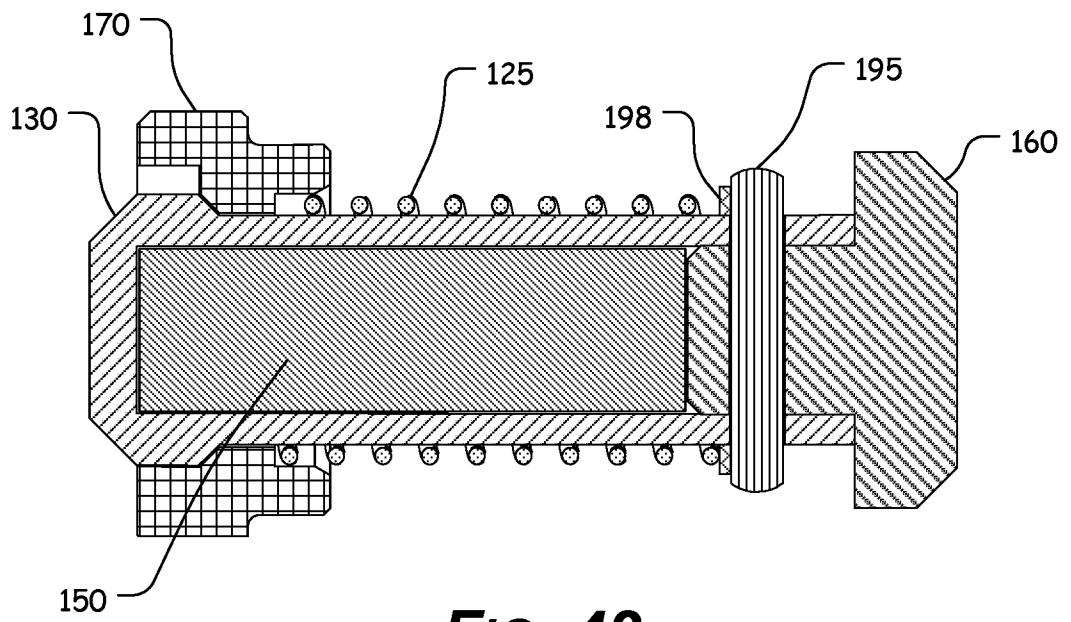


**FIG. 44**

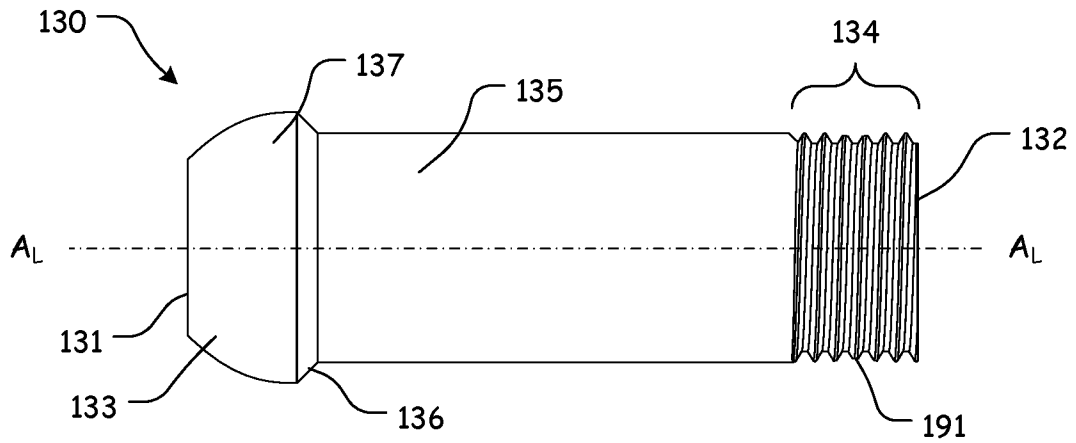


**FIG. 45**

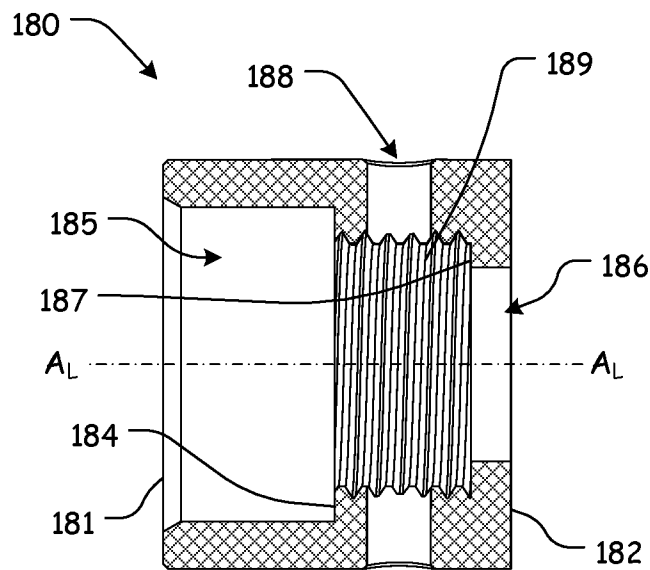




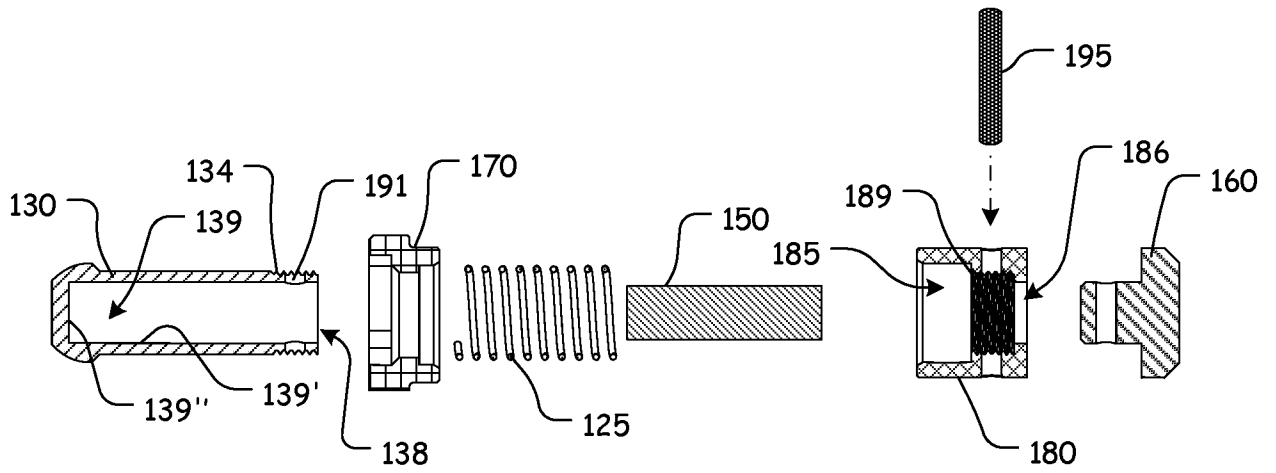
**FIG. 48**



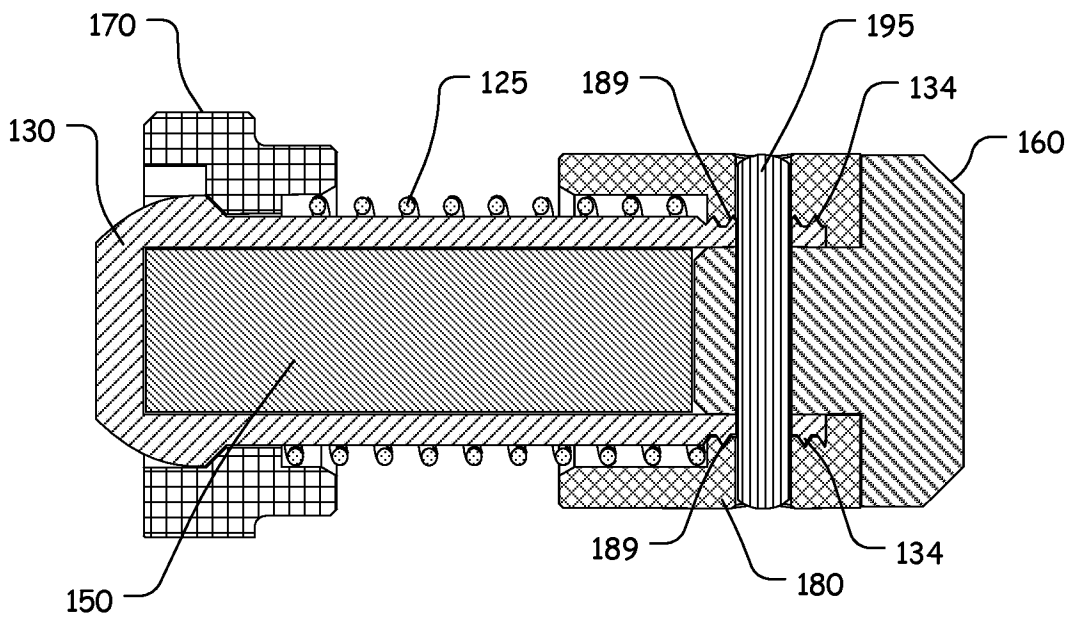
**FIG. 49**



**FIG. 50**



**FIG. 51**



**FIG. 52**