

(19) World Intellectual Property Organization  
International Bureau



(43) International Publication Date  
11 September 2009 (11.09.2009)

(10) International Publication Number  
**WO 2009/111712 A1**

- (51) International Patent Classification:  
*A61M 25/10* (2006.01) *A61L 29/00* (2006.01)
- (21) International Application Number:  
PCT/US2009/036354
- (22) International Filing Date:  
6 March 2009 (06.03.2009)
- (25) Filing Language: English
- (26) Publication Language: English
- (30) Priority Data:  
61/034,328 6 March 2008 (06.03.2008) US
- (71) Applicant (for all designated States except US):  
**BOSTON SCIENTIFIC SCIMED, INC.** [US/US]; One SCIMED Place, Maple Grove, Minnesota 55311-1566 (US).
- (72) Inventors; and
- (75) Inventors/Applicants (for US only): **KNAPP, David** [US/US]; 640 Evergreen Circle, Shoreview, Minnesota 55126 (US). **MICKLEY, Timothy** [US/US]; 21870 Xenon Street, Elk River, Minnesota 55330 (US). **CHEN, John** [US/US]; 4725 Terraceview Lane North, Plymouth, Minnesota 55446 (US). **SUTERMEISTER, Derek** [US/US]; 7320 Scot Terrace, Eden Prairie, Minnesota 55426 (US). **FREYMAN, Toby** [US/US]; 200 Warren Street, Waltham, Massachusetts 02453 (US). **KOCUR, Gordon**

[US/US]; 508 Lonesome Pine Trail, Lino Lakes, Minnesota 55014 (US). **HORN, Daniel** [US/US]; 291 Poplar Drive, Shoreview, Minnesota 55126 (US). **ANDERSON, Jim** [US/US]; 7513 Lakeside RD NE, Fridley, Minnesota 55432 (US). **ARCAND, Ben** [US/US]; 2400 24th Avenue S., Minneapolis, Minnesota 55406 (US). **RASSAT, Jay** [US/US]; 1230 Varner Way, Buffalo, Minnesota 55313 (US). **RIZQ, Raed** [US/US]; 7513 Inland Lane, Maple Grove, Minnesota 55311 (US). **NAZAROVA, Irina** [US/US]; 2610 Queensport Road, Woodbury, Minnesota 55125 (US). **QUILLIN, Dan** [US/US]; 11652 Mount Curve Road, Eden Prairie, Minnesota 55347 (US). **WEBER, Jan** [NL/NL]; Holdaal 49, NL-6228 GJ Maastricht (NL). **SCHEUERMANN, Torsten** [DE/DE]; Viktor-Scheffel Strasse 20, 80803 Munich (DE).

(74) Agents: **RINGEL, Douglas** et al.; Kenyon & Kenyon LLP, 1500 K Street N.W., Suite 700, Washington, District of Columbia 20005-1257 (US).

(81) Designated States (unless otherwise indicated, for every kind of national protection available): AE, AG, AL, AM, AO, AT, AU, AZ, BA, BB, BG, BH, BR, BW, BY, BZ, CA, CH, CN, CO, CR, CU, CZ, DE, DK, DM, DO, DZ, EC, EE, EG, ES, FI, GB, GD, GE, GH, GM, GT, HN, HR, HU, ID, IL, IN, IS, JP, KE, KG, KM, KN, KP, KR, KZ, LA, LC, LK, LR, LS, LT, LU, LY, MA, MD, ME, MG, MK, MN, MW, MX, MY, MZ, NA, NG, NI, NO, NZ, OM, PG, PH, PL, PT, RO, RS, RU, SC, SD, SE, SG,

[Continued on next page]

(54) Title: BALLOON CATHETER DEVICES WITH FOLDED BALLOONS

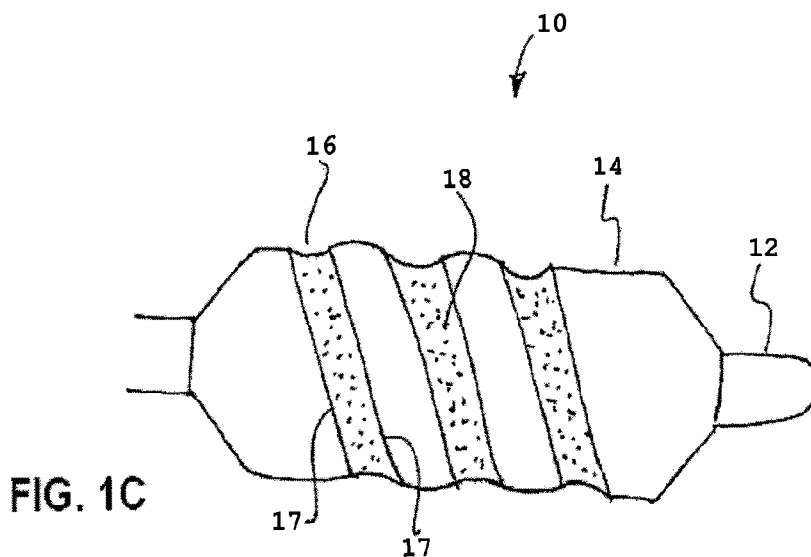

(57) Abstract: Catheter devices (10) having an expandable balloon (14) for delivering a therapeutic agent to a body site. The balloon has one or more folds (16) which serve as a reservoir for containing the therapeutic agent. The fold may have any of various configurations to hold the therapeutic agent. In some cases, the balloon comprises one or more lobes that forms the fold(s). The therapeutic agent may be provided in various ways. For example, the therapeutic agent may be contained in packets that rupture upon expansion of the balloon, or as a plurality of discrete bulk masses, or sealed within compartments.

WO 2009/111712 A1

SK, SL, SM, ST, SV, SY, TJ, TM, TN, TR, TT, TZ, UA,  
UG, US, UZ, VC, VN, ZA, ZM, ZW.

OAPI (BF, BJ, CF, CG, CI, CM, GA, GN, GQ, GW, ML,  
MR, NE, SN, TD, TG).

**(84) Designated States** (*unless otherwise indicated, for every kind of regional protection available*): ARIPO (BW, GH, GM, KE, LS, MW, MZ, NA, SD, SL, SZ, TZ, UG, ZM, ZW), Eurasian (AM, AZ, BY, KG, KZ, MD, RU, TJ, TM), European (AT, BE, BG, CH, CY, CZ, DE, DK, EE, ES, FI, FR, GB, GR, HR, HU, IE, IS, IT, LT, LU, LV, MC, MK, MT, NL, NO, PL, PT, RO, SE, SI, SK, TR),

**Published:**

- *with international search report (Art. 21(3))*
- *before the expiration of the time limit for amending the claims and to be republished in the event of receipt of amendments (Rule 48.2(h))*

## BALLOON CATHETER DEVICES WITH FOLDED BALLOONS

### RELATED APPLICATIONS

[0001] This application claims the benefit of provisional application Serial No. 61/034,328 (filed 6 March 2008), which is incorporated by reference herein.

### TECHNICAL FIELD

[0002] The present invention relates to medical devices, more particularly, to catheter devices.

### BACKGROUND

[0003] Catheters are used in a wide variety of minimally-invasive or percutaneous medical procedures. Balloon catheters having drug coatings may be used to treat diseased portions of blood vessels. Typically, the balloon is inserted through a peripheral blood vessel and then guided via a catheter through the vascular system to the target intravascular site. However, as the balloon travels through the vascular system, the flow of blood may wash away some of the drug coating. In addition, the control of the timing, location, and/or duration of the drug release can be an issue. Therefore, there is a need for improved catheter-based devices for drug delivery to an intravascular site.

### SUMMARY

[0004] In one embodiment, the present invention provides a medical device comprising: a catheter; a balloon mounted on the catheter, the balloon having a main body and at least one lobe that forms a fold, wherein the fold opens upon expansion of the balloon; and a therapeutic agent disposed within the fold, wherein opening of the fold upon expansion of the balloon promotes the release of the therapeutic agent.

[0005] In another embodiment, the present invention provides a medical device comprising: a catheter; a balloon mounted on the catheter, the balloon comprising at least one lobe forming a fold of the balloon, wherein the fold opens upon expansion of the balloon; and a packet disposed within the fold, the packet containing a therapeutic agent and having a first attachment site where

the packet is attached to the lobe and a second attachment site where the packet is attached to an adjacent surface of the balloon.

[0006] In another embodiment, the present invention provides a medical device comprising: a catheter; a balloon mounted on the catheter, the balloon having a plurality of folds that open upon expansion of the balloon; and a plurality of discrete bulk masses of therapeutic agent disposed within the folds, wherein the bulk masses of therapeutic agent are released upon opening of the folds.

#### BRIEF DESCRIPTION OF THE DRAWINGS

[0007] FIGS. 1A-1C show a catheter device according to an embodiment of the present invention. FIG. 1A shows the catheter device with the balloon in a deflated state. FIG. 1B shows an enlarged, cross-section view of a folded groove of the balloon. FIG. 1C shows the catheter device with the balloon inflated.

[0008] FIGS. 2A and 2B show a catheter device according to another embodiment. FIG. 2A shows the catheter device with the balloon in a deflated state. FIG. 2B shows the catheter device with the balloon inflated.

[0009] FIGS. 3A and 3B show a catheter device according to another embodiment. FIG. 3A shows the catheter device with the balloon in a deflated state. FIG. 3B shows the catheter device with the balloon inflated.

[0010] FIGS. 4A-4C show transverse cross-section views of a balloon according to another embodiment. FIG. 4A shows the balloon in a deflated state. FIG. 4B shows the balloon partially inflated. FIG. 4C shows the balloon fully inflated.

[0011] FIGS. 5A-5C show a balloon according to another embodiment. FIG. 5A shows a perspective view of the balloon in a deflated state. FIG. 5B shows a transverse, cross-section view of the balloon in FIG. 5A. FIG. 5C shows the balloon fully inflated.

[0012] FIGS. 6A and 6B show transverse cross-section views of a balloon according to another embodiment. FIG. 6A shows the balloon in a deflated state. FIG. 6B shows the balloon in a fully inflated state.

[0013] FIG. 7 shows a manufacturing step in the manufacture of a device like that in FIGS. 6A and 6B.

[0014] FIG. 8 shows a packet according to an embodiment that can be used with a device like that in FIGS. 6A and 6B.

[0015] FIG. 9 illustrates the direction of the forces pulling upon a packet.

[0016] FIG. 10 shows a bulk mass of a therapeutic agent according to an embodiment that can be used with a device like that in FIGS. 11A and 11B. FIGS. 11A and 11B show transverse cross-section views of a portion of a balloon wall according to an embodiment.

[0017] FIGS. 12A-12E show a catheter device according to another embodiment. FIGS. 12A (side view), 12B (transverse cross-section view), and 12C (enlarged, cross-section view of a compartment) show the balloon in a deflated state. FIGS. 12D (side view) and 12E (enlarged, cross-section view of a compartment) show the balloon in an inflated state.

[0018] FIGS. 13A-13C show a balloon during various stages of a manufacturing process according to an embodiment.

#### DETAILED DESCRIPTION

[0019] Catheter devices of the present invention use an expandable balloon for delivering a therapeutic agent to a target site in the body. The balloon is designed to be insertable in the body via a catheter. The therapeutic agent can be associated with the balloon in any of various ways, as further described below. Any of various mechanisms conventionally used for the delivery, actuation, or expansion (e.g., by inflation) of balloon catheter devices may be used in the present invention. The balloon catheter may be designed similar to those that have been known in the art, including but not limited to angioplasty catheters, stent delivery catheters, inflation catheters, and/or perfusion catheters. The catheter devices of the present invention may be used in conjunction with other drug delivery devices, such as stents.

[0020] The balloon has one or more folds which serve as reservoirs for containing a therapeutic agent. The folds may be oriented in any of various ways on the balloon, including, for example, longitudinally, radially, circumferentially, or helically. The folds may be made by any of the methods known in the art, including but not limited to methods described in U.S. Patent/Publication Nos. 5,342,307 (Enteneuer et al.), 5,147,302 (Enteneuer et al.), 5,458,572 (Campbell et al.), 5,954,740 (Ravenscroft et al.), 6,013,055 (Bampos et al.), 7,128,868

(Eidenschink), or 7,306,616 (Eidenschink et al.), 2004/0215227 (McMorrow et al.), which are all incorporated by reference herein.

**[0021]** The folds may have any of various configurations to hold the therapeutic agent. For example, the folds may be in the form of pockets, grooves, dimples, or wells. The folds are not limited to structures formed by the bending, creasing, or pleating of the balloon wall. Folds may also be formed as voids within the balloon wall itself (e.g., as grooves, channels, or trenches), which may be made during extrusion or by etching, stamping, laser ablation, or heat ablation of the balloon.

**[0022]** As the balloon is expanded (e.g., by inflation), the folds are made to open such that the therapeutic agent is exposed and allowed to be released. For example, referring to the embodiment shown in FIGS. 1A-1C, a catheter device 10 comprises a balloon 14 mounted on an elongate shaft 12. Balloon 14 has a folded groove 16 extending in a helical fashion around the circumference of balloon 14. As shown in the enlarged, cross-section view in FIG. 1B, when balloon 14 is in a deflated state, the edges 17 of folded groove 16 cooperate to form a compartment 19 holding a therapeutic agent 18. The edges 17 may touch or be close together and may be held together by, for example, an adhesive, biodegradable or bioerodable sutures or stitching, or some other means by which the edges may be held closely together or touching during balloon delivery but which will allow the edges to separate upon balloon expansion. The width, pitch, pitch angle, and depth of folded groove 16 on balloon 14 will vary depending upon the particular application.

**[0023]** In operation, balloon 14 is inserted into the body via a catheter. Because therapeutic agent 18 is contained within folded groove 16, therapeutic agent 18 is protected while balloon 14 is being guided to the target site. As shown in FIG. 1C, at the target site, balloon 14 is inflated, causing folded groove 16 to widen and causing edges 17 of folded groove 16 to separate, thus exposing therapeutic agent 18 for release at the target site.

**[0024]** In another example, referring to the embodiment shown in FIGS. 2A and 2B, a catheter device 20 comprises a balloon 24 mounted on an elongate shaft 22. Balloon 24 has a plurality of folded grooves 26 extending in a radial fashion around the circumference of balloon 24. When balloon 24 is in a deflated state, the edges 27 of grooves 26 cooperate to form compartments holding therapeutic agent 18. The edges 27 may touch or be close together and may be held together as described above. The cross-section of a groove 26 may be similar to

that shown in FIG. 1B. The number, width, pitch, and depth of folded grooves 26 on balloon 24 will vary depending upon the particular application.

[0025] In operation, balloon 24 is inserted into the body via a catheter. Because therapeutic agent 18 is contained within folded groove 26, therapeutic agent 18 is protected while balloon 24 is being guided to the target site. As shown in FIG. 2B, at the target site, balloon 24 is inflated, causing groove 26 to widen and causing edges 27 of folded groove 26 to separate, thus exposing therapeutic agent 18 for release at the target site.

[0026] In certain embodiments of the invention, the configuration of the balloon and the therapeutic agent reservoirs can be controlled such as to allow release of the therapeutic agent only at the desired time. For example, the device may be designed such that a certain pressure within the balloon is required for the folds to open and release the therapeutic agent. In this way, the therapeutic agent can be held in the folds while the device is delivered through the blood vessel to the target site. Then, at the target site, the balloon is inflated, and when the balloon reaches the pressure and/or diameter at which the folds are designed to open, the therapeutic agent will be released. In this way, for example, the therapeutic agent release can be controlled such that it is released only if the balloon is in contact with or in close proximity to the vessel wall. This helps to prevent loss of the therapeutic agent during catheter placement and balloon inflation. Also, because deflation of the balloon can, in some instances, stop or substantially reduce therapeutic agent release, certain embodiments of the invention can control the duration of release after the initial release of therapeutic agent.

[0027] In certain embodiments, the balloon comprises one or more lobes (e.g., a wing, a bi-fold wing, a T-wing, or a cuff) that forms the one or more folds. For example, referring to the embodiment shown in FIGS. 3A and 3B, a catheter device 30 comprises a balloon 34 mounted on an elongate shaft 32. Balloon 34 comprises a cylindrical main body 31, which is coated with a therapeutic agent 18, and two circumferential cuff portions 36. When the balloon is in an unexpanded state, cuff portions 36 assume a low profile to allow insertion of the balloon into a catheter and/or blood vessel. The interior 37 of cuff portions 36 are in communication with the inflation chamber 35 of main body 31. As shown in FIG. 3A, when balloon 34 is in a deflated state, cuff portions 36 are folded over balloon 34 such that cuff portions 36 cover therapeutic agent 18. In certain embodiments, only the surfaces of balloon 34 that are covered by cuff portions 36 when in a deflated state are coated with the therapeutic agent.

[0028] In operation, balloon 34 is inserted into a blood vessel via a catheter. Because cuff portions 36 cover therapeutic agent 18, therapeutic agent 18 is protected while balloon 34 is being guided to the target site. At the target site, as shown in FIG. 3B, balloon 34 is inflated, causing cuff portions 36 to extend outward in a radial direction, thus exposing therapeutic agent 18 for release at the target site. In an example embodiment, when the cuff portions 36 are fully extended radially, each cuff portion has a length of between about 1/4 of the entire length of balloon 34 to 1/2 of the entire length of balloon 34. Also, by extending in a radial direction, cuff portions 36 can also abut against the vessel wall 38 and seal the space between cuff portions 36. In this way, therapeutic agent 18 can be applied to vessel wall 38 while reducing the amount of therapeutic agent 18 washed away downstream by the flow of blood.

[0029] In another example, referring to the embodiment shown in FIGS. 4A-4C, a catheter device comprises a balloon 60, which has a plurality of inflatable bi-fold wings 62 and an inflatable central body 64. When the balloon is in an unexpanded state, bi-fold wings 62 assume a low profile to allow insertion of the balloon into a catheter and/or blood vessel. The interior 66 of bi-fold wings 62 are in communication with the inflation chamber 65 of central body 64. As shown in FIG. 4A, when balloon 60 is in a deflated state, a therapeutic agent 18 is sandwiched between the folds of bi-fold wings 62. Also, when balloon 60 is in a deflated state, bi-fold wings 62 circumferentially wrap around central body 64.

[0030] In operation, balloon 60 is inserted into the body via a catheter. Because therapeutic agent 18 is sandwiched between the folds of bi-fold wings 62, therapeutic agent 18 is protected while balloon 60 is being guided to the target site. At the target site, as shown in FIG. 4B, balloon 60 is inflated, causing bi-fold wings 62 to extend outward. As shown in FIG. 4C, with further inflation, balloon 60 assumes a more cylindrical shape, in which therapeutic agent 18 is exposed on the outer surface of balloon 60 to facilitate application of therapeutic agent 18 to the body tissue.

[0031] In another example, referring to the embodiment shown in FIGS. 5A-5C, a catheter device comprises a balloon 90, which has a plurality of inflatable T-wings 92 and an inflatable central body 94. The interior 96 of T-wings 92 are in communication with the inflation chamber 95 of central body 94. As shown in FIG. 5B, when balloon 90 is in a deflated state, a therapeutic agent 18 coats the inside surfaces of T-wings 92 (i.e., the undersides 99 and stems 98 of T-wings 92).



[0032] In operation, balloon 90 is inserted into a patient's body via a catheter. Because therapeutic agent 18 is located on a non-exposed surface of balloon 90, therapeutic agent 18 is protected while balloon 90 is being guided to the target site. As balloon 90 is inflated, T-wings 92 assume a less distinctive shape. As shown in FIG. 5C, as balloon 90 is inflated, T-wings 92 expand outward such that balloon 90 assumes a more cylindrical shape, in which therapeutic agent 18 is exposed on the outer surface of balloon 90 to facilitate application of therapeutic agent 18 to the body tissue.

[0033] In some cases, one or more packets containing the therapeutic agent may be disposed within the folds that are created by the lobes of the balloon. The packet is attached to two or more sites on the surface of the balloon at two or more different sites on the packet. As the balloon is expanded, the balloon applies a pulling force on the packet, causing the packet to rupture and allow release of the therapeutic agent.

[0034] The walls of the packet may or may not be distinct from the walls of the balloon. In some cases, at least a portion of the packet shares the same wall as the balloon. In some cases, the packet may be manufactured separately from the balloon and then attached to the balloon. In such cases, the walls of the packet may be distinct from the walls of the balloon. The packet may have various three-dimensional shapes suitable for fitting within the folds of the balloon, including rectangular cuboid, cylindrical, spheroid, or ellipsoid shapes. The packet may or may not have an elongate shape. The packet may or may not be completely sealed.

[0035] The packet has a tensile rupture strength, which is the amount of stretching force required to rupture the packet. To allow the packet to rupture upon expansion of the balloon, the strength of the attachment between the packet and the balloon will exceed the tensile rupture strength of the packet. The tensile rupture strength of the packet and/or the stretching force applied to the packet may be varied to create a design such that the packets rupture upon expansion of the balloon. For example, adjustments can be made to various parameters, such as the structural, geometric, and/or material characteristics of the packet; the spatial geometry of the attachment sites on the packet; the structural, geometric, and/or material characteristics of the balloon; and the dynamic geometry of the balloon as it expands. For example, the tensile rupture strength of the packet may be reduced by making the packet with thinner walls. In some cases, the packet may be made with a soft and pliable polymeric material to prevent premature rupture

of the packet. For example, the packet may be made of polyurethane, especially when the balloon is also made of polyurethane.

**[0036]** The packet may contain a single therapeutic agent or a mixture of different therapeutic agents. In cases where the balloon has a plurality of packets, different packets may contain different therapeutic agents. The therapeutic agent may be provided in any suitable formulation or dosage form, such as capsules or nanoparticles (e.g., albumin-bound paclitaxel, sold as Abraxane® (Astra-Zeneca)). The packet may further contain an excipient material to facilitate delivery of the therapeutic agent. For example, the packet may contain a viscous material for adhering the therapeutic agent to the tissue. Examples of viscous materials which may be suitable for use include bioabsorbable waxes, pastes, binders (e.g., polyvinyl pyrrolidone), plasticizers, gels, proteins (e.g., albumin, fibrinogen, or gelatin), fats, or biodegradable polymers (e.g., glycerol, polylactic acid, or polyglycolic acid).

**[0037]** For example, referring to the embodiment shown in FIGS. 6A and 6B (transverse cross-section views), a catheter device comprises an elongate balloon 100 mounted on an elongate shaft 102. Balloon 100 has a plurality of lobes 104 that form one or more folds. Disposed within the folds of balloon 100 are elongate strip-shaped packets 106 that hold a therapeutic agent 108. Strip-shaped packets 106 are oriented parallel to the longitudinal axis of elongate balloon 100. Packets 106 are adhered between a lobe 104 and an adjacent surface of the balloon 100 or between adjacent lobes 104 of balloon 100. As shown here, packets 106 face the balloon surface at its “top” face 103 and “bottom” face 105, which are the sites at which packet 106 is adhered to the balloon surface.

**[0038]** In operation, balloon 100 is inserted into the body via a catheter. Because packets 106 of therapeutic agent are contained within the folds created by lobes 104, the therapeutic agent is protected while balloon 100 is being guided to the target site. As shown in FIG. 6B, upon inflation of balloon 100, lobes 106 expand outward and open the folds. This expansion of lobes 106 pull apart packet 106 at its attachment sites causing packets 106 to rupture. As shown in FIG. 6B, rupture of packets 106 (leaving its remnants 107) allows the release of therapeutic agent 108.

**[0039]** FIG. 7 shows one manner by which balloon 100 in FIG. 6A may be made. With balloon 100 in an uninflated state, lobes 104 are unfolded to expose their sides. An adhesive is applied onto the “top” and “bottom” faces of packets 106. Packets 106 are adhered onto one side

of lobes 104. Lobes 104 are then folded over such that the other side of each packet 106 is adhered to an adjacent surface of balloon 100.

**[0040]** The packets may be designed in such a way to facilitate their rupture. For example, FIG. 8 shows a rectangular-cuboid shaped packet 120 containing a therapeutic agent 128. Packet 120 has a top face 122, a bottom face 124, and lateral faces 126. The wall of packet 120 is thicker at the top face 122 and bottom face 124, which are the sites of attachment to the balloon, and thinner at the lateral faces 126. Thus, when top face 122 is pulled apart from bottom face 124 as the balloon is inflated, packet 120 will preferentially rupture at the lateral walls 126.

**[0041]** In the embodiment shown in FIG. 6A, the attachment sites are on substantially opposite faces of packet 106, with the attachment sites being pulled apart in opposite directions when balloon 100 is inflated. However, the attachment sites do not necessarily have to be located on opposite faces or be pulled apart in opposite directions, so long as the forces pulling upon the attachment sites are sufficient to rupture the packets. In some cases, the balloon and/or packets may be designed such that the attachment sites are pulled apart at an angle in the range of  $60 - 180^\circ$  as the balloon is inflated. To illustrate, FIG. 9 shows an ovoid-shaped packet 110 containing a therapeutic agent 111. Packet 110 is attached to lobes 116 of a balloon at attachment sites 112 and 114. Arrows 118 and 119 represent the direction vector in which lobes 116 will pull on packet 110 as the balloon is inflated. In some embodiments, the angle  $\theta$  between these two vectors is in the range of  $60 - 180^\circ$ , but other angles are also possible.

**[0042]** The use of packets as described herein allows for the containment of the therapeutic agent during manufacturing and/or delivery of the medical device into a blood vessel. Thus, the therapeutic agent is protected from the environment and from early release until the device is at the target site and the balloon is inflated. Also, the use of packets as well as the use of therapeutic agent reservoirs as described above can allow for the use of therapeutic agents (or formulation mixtures thereof) that could not otherwise be used because of lack of adherence to the balloon.

**[0043]** Also, the packets can be designed to protect the therapeutic agent in cases where the device is subjected to a sterilization process. For example, the packets can be sealed or have walls that are thicker or made of a less permeable material to make the packets in-penetrable to the sterilization process. As such, a wider range of sterilizations processes for the device can be made available, even some that may otherwise be harmful to an openly exposed therapeutic

agent. For example, if it is desirable to use ethylene oxide to sterilize the device but the therapeutic agent is sensitive to ethylene oxide, the packets could be designed to be impermeable to ethylene oxide to protect the therapeutic agent contained inside. Furthermore, in cases where a vascular stent is crimped onto the balloon, the packets can be designed to withstand the forces that are applied during crimping of the stent onto the balloon.

**[0044]** The number of lobes and packets may vary, with possibly multiple packets per lobe. Also, the shape of the lobes can vary. For example, the lobes may be configured like the cuffs or wings shown in FIGS. 3A, 3B, 4A, 4B, 5A, and 5B, with the packets being adhered in the places where the therapeutic agent is shown in these figures.

**[0045]** In certain embodiments, the therapeutic agent is provided as a plurality of bulk masses that are disposed within the folds. The bulk masses of therapeutic agent are discrete, i.e., distinct and detached from each other. The bulk masses of therapeutic agent may have any of various three-dimensional shapes suitable for fitting within the folds of the balloon, including rectangular cuboid, cylindrical, spheroid, or ellipsoid shapes. For example, the bulk masses of therapeutic agent may have an elongate shape in the form of rods, ribbons, strips, or fibers. The balloon may have from 10 to 1000 individual bulk masses of therapeutic agent disposed thereon, but other quantities are also possible depending upon the particular application.

**[0046]** The bulk masses of therapeutic agent may be thicker than the typical thickness of conventional drug coatings on balloons. For example, the bulk masses may have a thickness in the range of 10 – 150  $\mu\text{m}$ , and in some cases, in the range of 25 – 100  $\mu\text{m}$ , but larger or smaller thicknesses are also possible. The length of each bulk mass may be as small as 0.25 mm or smaller, and may range up to the entire length of the balloon (e.g., 8 mm for coronary artery balloons or 200 mm for peripheral artery balloons) or longer. In cases where paclitaxel is the therapeutic agent, each bulk mass may contain, for example, from 0.1 to 100  $\mu\text{g}$  of paclitaxel.

**[0047]** For example, referring to the embodiment shown in FIG. 10, a bulk mass of therapeutic agent has the shape of a rod 150. Referring to the embodiment shown in FIG. 11A (transverse cross-section view), the wall 152 of an elongate balloon is creased into folds 154 that extend longitudinally along the length of the balloon. Folds 154 contain the rods 150 of therapeutic agent. The folds may have edges similar to those described above with respect to FIG. 1B.

[0048] In operation, the balloon is inserted into the body via a catheter. Because rods 150 of therapeutic agent are contained within folds 154, rods 150 are protected while the balloon is being guided to the target site. As shown in FIG. 11B, when the balloon is delivered to the target site and inflated, folds 154 open such that rods 150 are released from the balloon.

[0049] The bulk mass of therapeutic agent may be formed in any suitable way known in the art. For example, rods 150 may be made by preparing a liquid formulation of the therapeutic agent in a solvent. The liquid formulation of therapeutic agent is then applied into folds 154 of the balloon (e.g., by spraying or dip coating). The liquid formulation is then dried such that the solid residue of therapeutic agent is cast into the shape of fold 154 (i.e., as a rod shape). The shaping may be aided by crystallization of the therapeutic agent as it is dried. Also, shaping may be aided by adding other materials, such as binders, plasticizers, polymeric materials, metallic materials, or radiocontrast agents into the liquid formulation. Alternatively, rods 150 may be made separately and then inserted into folds 154 of the balloon. The bulk masses may be, for example, polymeric, organic, and/or metal, and may be biostable, bioresorbable, bioerodable, or biodegradable. In some embodiments, the rods 150 of therapeutic agent may be localized to particular segments of the balloon. This feature may be useful in avoiding delivery of the therapeutic agent to segments of an artery containing calcified lesions. In some cases, the bulk masses may be implantable in the target tissue (e.g., blood vessel wall).

[0050] In certain embodiments, the edges of a fold may come together to form a sealed compartment for containing the therapeutic agent. For example, referring to the embodiment shown in FIGS. 12A-12E, a catheter device comprises a balloon 134 mounted on an elongate shaft 132. In its interior, balloon 134 has an inflation chamber 136, and on its exterior, balloon 134 has a plurality of longitudinal folds 140. As seen in FIGS. 12B and 12C, the edges 144 of folds 140 meet to create a compartment 148 for containing a therapeutic agent 18. Furthermore, the edges 144 of folds 140 can each have an adhesive strip 146 that are mutually aligned with each other. The edges 144 of folds 140 can be joined together by contact between adhesive strips 146 such that therapeutic agent 18 is sealed within compartment 148.

[0051] In operation, balloon 134 is inserted into a patient's body via a catheter. Because therapeutic agent 18 is sealed within compartments 148, therapeutic agent 18 is protected as balloon 134 is being guided to the target site. At the target site, balloon 134 is inflated, causing adhesive strips 146 to pull apart. As shown in FIGS. 12D and 12E, as balloon 134 continues to

expand, adhesive strips 146 detach such that edges 144 open, allowing therapeutic agent 18 to be released from compartment 148. In an alternate embodiment, the edges 144 of folds 140 can be sealed by other means, such as laser welding, heat setting, or by other holding means such as biodegradable or bioerodable sutures or stitching.

**[0052]** Folds containing the therapeutic agent may be formed in various ways. One way of making folds in the balloon is shown with reference to FIGS. 13A-13C, which show transverse cross-sections of a balloon (having a balloon wall 252). Referring to FIG. 13A, a therapeutic agent 18 (either free or formulated with a carrier material) is deposited on the surface 250 of the balloon as stripes that are oriented substantially longitudinally along the balloon. Referring to FIG. 13B, the areas between the stripes of therapeutic agent 18 is coated with a hydrophobic layer 254 formed of a hydrophobic material (e.g., hydrophobic polymers, such as styrene-isobutylene-styrene (SIBS) block copolymers or styrene-ethylene/butylene-styrene (SEBS) block copolymers). Referring to FIG. 13C, the balloon is folded around the stripes of therapeutic agent 18 to create folds 256 which contain the stripes of therapeutic agent 18. The edges 258 of folds 256 meet such that therapeutic agent 18 is sealed within folds 256. The hydrophobic material can help retard fluid penetration to slow or prevent the release of therapeutic agent until the desired time.

**[0053]** Therapeutic agent 18 may be released from folds 256 upon inflation of the balloon at the target site, which causes the edges 258 of folds 256 to pull apart, allowing the release of therapeutic agent 18. Alternatively, the edges 258 of folds 256 do not pull apart and therapeutic agent 18 is released by diffusion through hydrophobic layer 254.

**[0054]** In certain embodiments, the balloon is designed such that the folds open when the balloon reaches a certain pressure or a certain expanded diameter, such as when the balloon is close to abutting against the wall of a blood vessel (i.e., the internal diameter of the blood vessel). In certain embodiments, when the balloon is inflated and as the folds open, the folds form a protruding structure that projects outwardly from the main body of the balloon.

**[0055]** Medical devices of the present invention may also include a vascular stent mounted on the balloon. The vascular stent may be any of those known in the art, including those with or without coatings that elute a therapeutic agent. The stent may also be biostable, bioerodable, or biodegradable.

[0056] The balloons of the present invention may also be coated with a low-molecular weight carbohydrate, such as mannitol. The carbohydrate may be a separate coating or be blended with the therapeutic agent. The balloons of the present invention may also be coated with a radiocontrast agent (ionic or non-ionic), such as iopromide. The contrast agent may be a separate coating or be blended with the therapeutic agent.

[0057] The therapeutic agent used in the present invention may be any pharmaceutically-acceptable agent such as a drug, a non-genetic therapeutic agent, a biomolecule, a small molecule, or cells. Example drugs include anti-proliferative agents or anti-restenosis agents such as paclitaxel, sirolimus (rapamycin), tacrolimus, everolimus, and zotarolimus.

[0058] Exemplary non-genetic therapeutic agents include anti-thrombogenic agents such as heparin, heparin derivatives, prostaglandin (including micellar prostaglandin E1), urokinase, and PPACK (dextrophenylalanine proline arginine chloromethylketone); anti-proliferative agents such as enoxaparin, angiopeptin, sirolimus (rapamycin), tacrolimus, everolimus, zotarolimus, monoclonal antibodies capable of blocking smooth muscle cell proliferation, hirudin, and acetylsalicylic acid; anti-inflammatory agents such as dexamethasone, rosiglitazone, prednisolone, corticosterone, budesonide, estrogen, estradiol, sulfasalazine, acetylsalicylic acid, mycophenolic acid, and mesalamine; anti-neoplastic/anti-proliferative/anti-mitotic agents such as paclitaxel, epothilone, cladribine, 5-fluorouracil, methotrexate, doxorubicin, daunorubicin, cyclosporine, cisplatin, vinblastine, vincristine, epothilones, endostatin, trapidil, halofuginone, and angiostatin; anti-cancer agents such as antisense inhibitors of c-myc oncogene; anti-microbial agents such as triclosan, cephalosporins, aminoglycosides, nitrofurantoin, silver ions, compounds, or salts; biofilm synthesis inhibitors such as non-steroidal anti-inflammatory agents and chelating agents such as ethylenediaminetetraacetic acid, O,O'-bis (2-aminoethyl) ethyleneglycol-N,N,N',N'-tetraacetic acid and mixtures thereof; antibiotics such as gentamycin, rifampin, minocyclin, and ciprofloxacin; antibodies including chimeric antibodies and antibody fragments; anesthetic agents such as lidocaine, bupivacaine, and ropivacaine; nitric oxide; nitric oxide (NO) donors such as linsidomine, molsidomine, L-arginine, NO-carbohydrate adducts, polymeric or oligomeric NO adducts; anti-coagulants such as D-Phe-Pro-Arg chloromethyl ketone, an RGD peptide-containing compound, heparin, antithrombin compounds, platelet receptor antagonists, anti-thrombin antibodies, anti-platelet receptor antibodies, enoxaparin, hirudin, warfarin sodium, Dicumarol, aspirin, prostaglandin inhibitors, platelet aggregation

inhibitors such as cilostazol and tick antiplatelet factors; vascular cell growth promoters such as growth factors, transcriptional activators, and translational promoters; vascular cell growth inhibitors such as growth factor inhibitors, growth factor receptor antagonists, transcriptional repressors, translational repressors, replication inhibitors, inhibitory antibodies, antibodies directed against growth factors, bifunctional molecules consisting of a growth factor and a cytotoxin, bifunctional molecules consisting of an antibody and a cytotoxin; cholesterol-lowering agents; vasodilating agents; agents which interfere with endogenous vasoactive mechanisms; inhibitors of heat shock proteins such as geldanamycin; angiotensin converting enzyme (ACE) inhibitors; beta-blockers;  $\beta$ AR kinase ( $\beta$ ARK) inhibitors; phospholamban inhibitors; protein-bound particle drugs such as ABRAXANE™; structural protein (e.g., collagen) cross-link breakers such as alagebrium (ALT-711); any combinations and prodrugs of the above.

**[0059]** Exemplary biomolecules include peptides, polypeptides and proteins; oligonucleotides; nucleic acids such as double or single stranded DNA (including naked and cDNA), RNA, antisense nucleic acids such as antisense DNA and RNA, small interfering RNA (siRNA), and ribozymes; genes; carbohydrates; angiogenic factors including growth factors; cell cycle inhibitors; and anti-restenosis agents. Nucleic acids may be incorporated into delivery systems such as, for example, vectors (including viral vectors), plasmids or liposomes.

**[0060]** Non-limiting examples of proteins include serca-2 protein, monocyte chemoattractant proteins (MCP-1) and bone morphogenic proteins (“BMP’s”), such as, for example, BMP-2, BMP-3, BMP-4, BMP-5, BMP-6 (VGR-1), BMP-7 (OP-1), BMP-8, BMP-9, BMP-10, BMP-11, BMP-12, BMP-13, BMP-14, BMP-15. Preferred BMP’s are any of BMP-2, BMP-3, BMP-4, BMP-5, BMP-6, and BMP-7. These BMPs can be provided as homodimers, heterodimers, or combinations thereof, alone or together with other molecules. Alternatively, or in addition, molecules capable of inducing an upstream or downstream effect of a BMP can be provided. Such molecules include any of the “hedghog” proteins, or the DNA’s encoding them. Non-limiting examples of genes include survival genes that protect against cell death, such as anti-apoptotic Bcl-2 family factors and Akt kinase; serca 2 gene; and combinations thereof. Non-limiting examples of angiogenic factors include acidic and basic fibroblast growth factors, vascular endothelial growth factor, epidermal growth factor, transforming growth factors  $\alpha$  and  $\beta$ , platelet-derived endothelial growth factor, platelet-derived growth factor, tumor necrosis factor  $\alpha$ , hepatocyte growth factor, and insulin-like growth factor. A non-limiting example of a cell cycle



inhibitor is a cathepsin D (CD) inhibitor. Non-limiting examples of anti-restenosis agents include p15, p16, p18, p19, p21, p27, p53, p57, Rb, nFkB and E2F decoys, thymidine kinase and combinations thereof and other agents useful for interfering with cell proliferation.

[0061] Exemplary small molecules include hormones, nucleotides, amino acids, sugars, and lipids and compounds have a molecular weight of less than 100kD.

[0062] Exemplary cells include stem cells, progenitor cells, endothelial cells, adult cardiomyocytes, and smooth muscle cells. Cells can be of human origin (autologous or allogenic) or from an animal source (xenogenic), or genetically engineered. Non-limiting examples of cells include side population (SP) cells, lineage negative (Lin<sup>-</sup>) cells including Lin<sup>-</sup>CD34<sup>-</sup>, Lin<sup>-</sup>CD34<sup>+</sup>, Lin<sup>-</sup>cKit<sup>+</sup>, mesenchymal stem cells including mesenchymal stem cells with 5-aza, cord blood cells, cardiac or other tissue derived stem cells, whole bone marrow, bone marrow mononuclear cells, endothelial progenitor cells, skeletal myoblasts or satellite cells, muscle derived cells, go cells, endothelial cells, adult cardiomyocytes, fibroblasts, smooth muscle cells, adult cardiac fibroblasts + 5-aza, genetically modified cells, tissue engineered grafts, MyoD scar fibroblasts, pacing cells, embryonic stem cell clones, embryonic stem cells, fetal or neonatal cells, immunologically masked cells, and teratoma derived cells. Any of the therapeutic agents may be combined to the extent such combination is biologically compatible.

[0063] The foregoing description and examples have been set forth merely to illustrate the invention and are not intended to be limiting. Each of the disclosed aspects and embodiments of the present invention may be considered individually or in combination with other aspects, embodiments, and variations of the invention. Modifications of the disclosed embodiments incorporating the spirit and substance of the invention may occur to persons skilled in the art and such modifications are within the scope of the present invention.

## CLAIMS

We claim:

1. A medical device comprising:  
a catheter;  
a balloon mounted on the catheter, the balloon having a main body and at least one lobe that forms a fold, wherein the fold opens upon expansion of the balloon; and  
a therapeutic agent disposed within the fold, wherein opening of the fold upon expansion of the balloon promotes the release of the therapeutic agent.
2. The medical device of claim 1, wherein the at least one lobe is a wing.
3. The medical device of claim 2, wherein the balloon assumes a substantially cylindrical shape when the balloon is fully expanded, and wherein the therapeutic agent is disposed on the outer surface of the cylindrical-shaped balloon when the balloon is fully expanded.
4. The medical device of claim 2, wherein the wing is a bi-fold wing and the therapeutic agent is disposed between the folds of the bi-fold wing.
5. The medical device of claim 2, wherein the wing is a T-wing and the therapeutic agent is disposed on the inside surface of the T-wing.
6. The medical device of claim 1, wherein the at least one lobe is a circumferential cuff.
7. The medical device of claim 6, wherein the circumferential cuff is dimensioned such that, when the balloon is deployed in a blood vessel and the circumferential cuff is extended, the circumferential cuff abuts against the blood vessel wall.
8. The medical device of claim 7, wherein the balloon has two circumferential cuffs, and wherein the therapeutic agent is sealed between the two circumferential cuffs when the balloon is deployed and the circumferential cuffs are extended.

9. The medical device of claim 1, wherein the therapeutic agent is disposed only within the fold when the balloon is in an unexpanded state.
10. The medical device of claim 1, wherein the fold is oriented circumferentially or helically around the main body of the balloon.
11. The medical device of claim 1, wherein the fold is sealed at the edges by an adhesive.
12. A medical device comprising:
  - a catheter;
  - a balloon mounted on the catheter, the balloon comprising at least one lobe forming a fold of the balloon, wherein the fold opens upon expansion of the balloon; and
  - a packet disposed within the fold, the packet containing a therapeutic agent and having a first attachment site where the packet is attached to the lobe and a second attachment site where the packet is attached to an adjacent surface of the balloon.
13. The medical device of claim 12, wherein the walls of the packet are distinct from the walls of the balloon.
14. The medical device of claim 12, wherein the strength of the attachment between the packet and the balloon exceeds the tensile rupture strength of the packet.
15. The medical device of claim 12, wherein expansion of the balloon causes rupture of the packet.
16. The medical device of claim 12, wherein the packet has a first face and a second face, wherein the first attachment site is located on the first face of the packet, and the second attachment site is located on the second face of the packet.

17. The medical device of claim 12, wherein expansion of the balloon causes the lobe to pull on the packet, and wherein the angle between the pulling direction at the first attachment site and the pulling direction at the second attachment site is in the range of 60 – 180°.

18. The medical device of claim 12, wherein the first attachment site is located substantially opposite the second attachment site of the packet.

19. A medical device comprising:

a catheter;

a balloon mounted on the catheter, the balloon having a plurality of folds that open upon expansion of the balloon; and

a plurality of discrete bulk masses of therapeutic agent disposed within the folds, wherein the bulk masses of therapeutic agent are released upon opening of the folds.

20. The medical device of claim 19, wherein the bulk masses have a thickness in the range of 10 – 150  $\mu\text{m}$ .

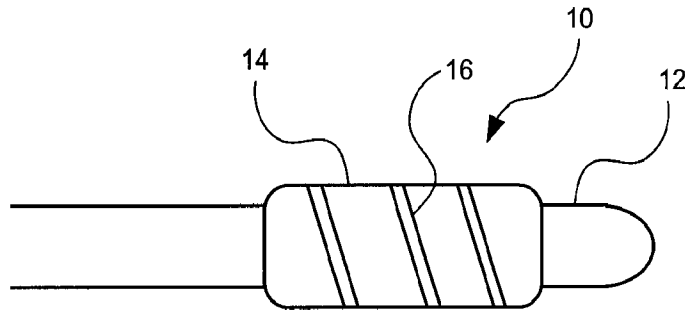

FIG. 1A

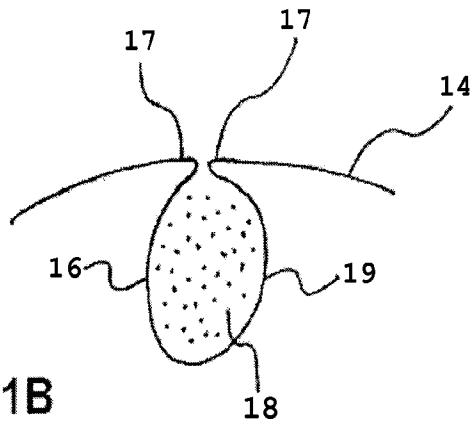

FIG. 1B

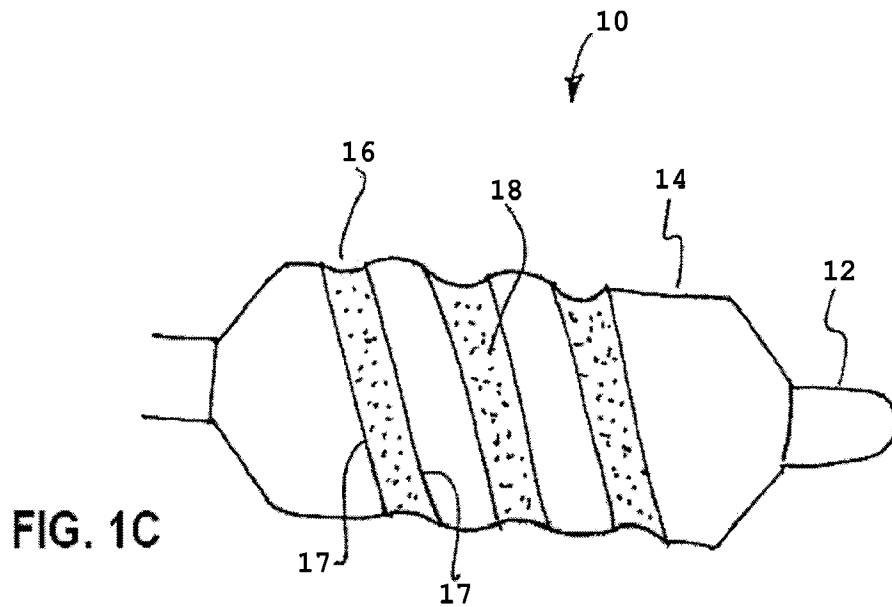

FIG. 1C

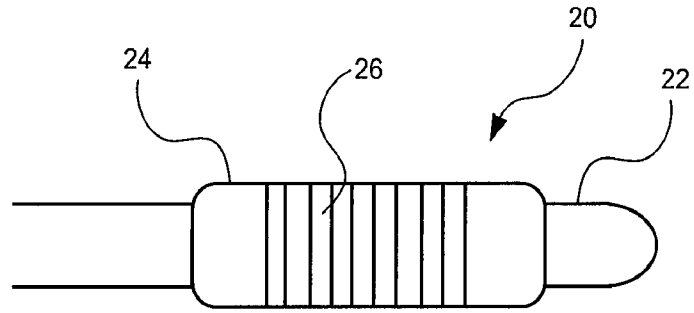

FIG. 2A

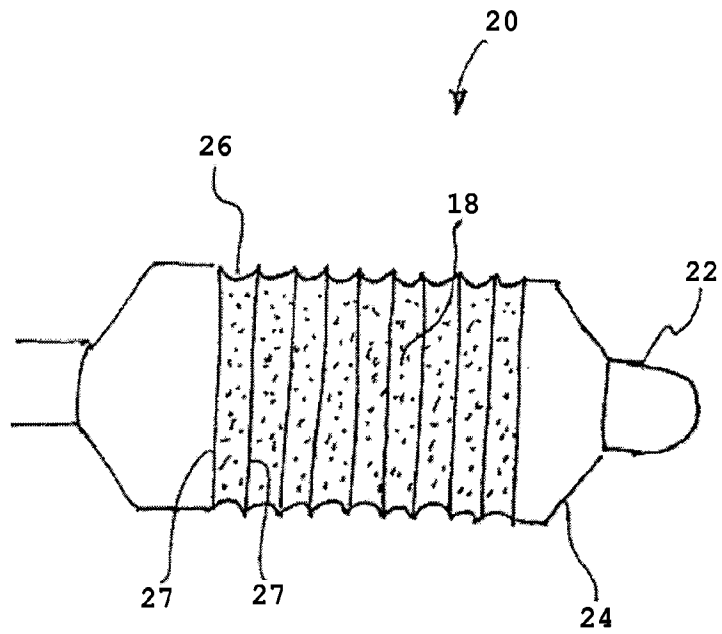

FIG. 2B

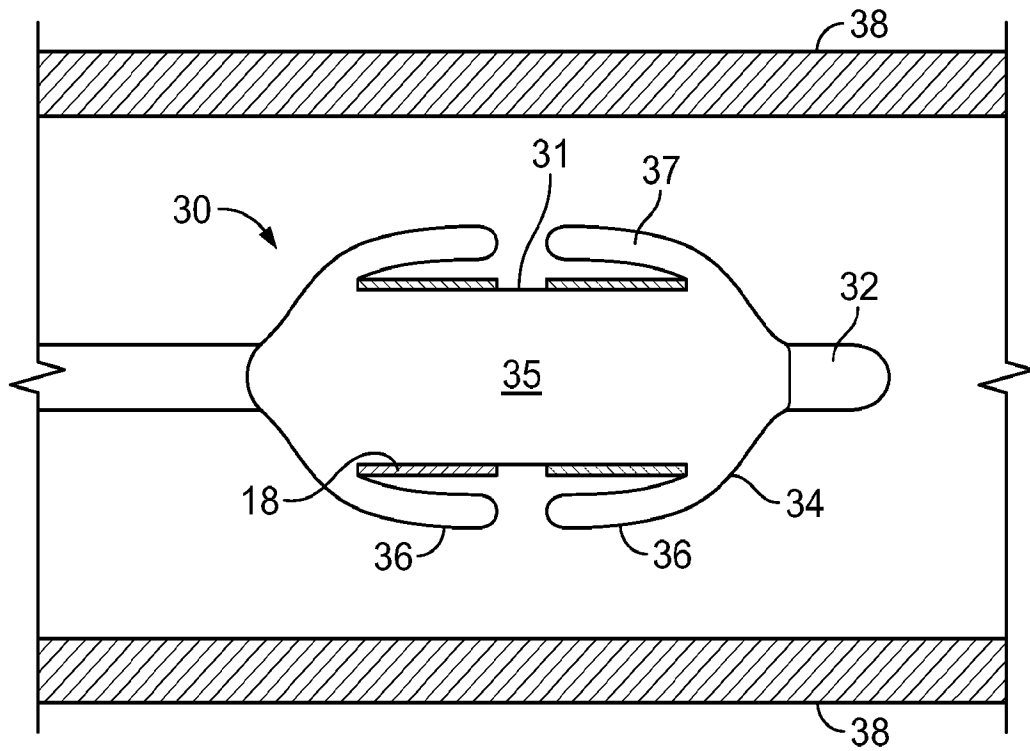

FIG. 3A

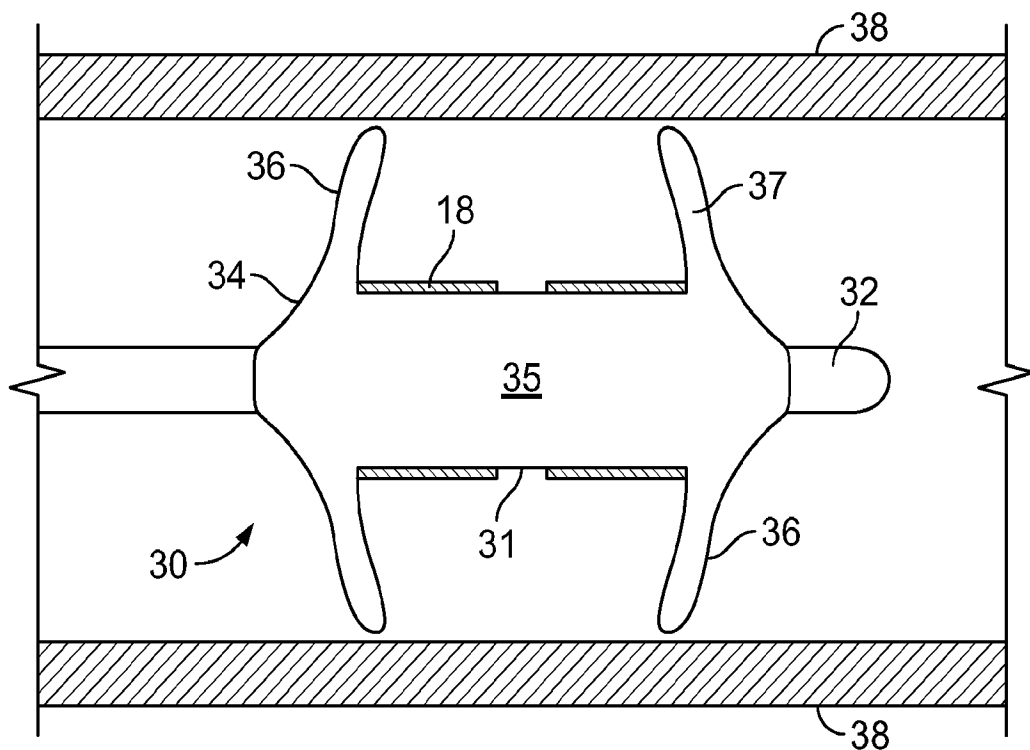
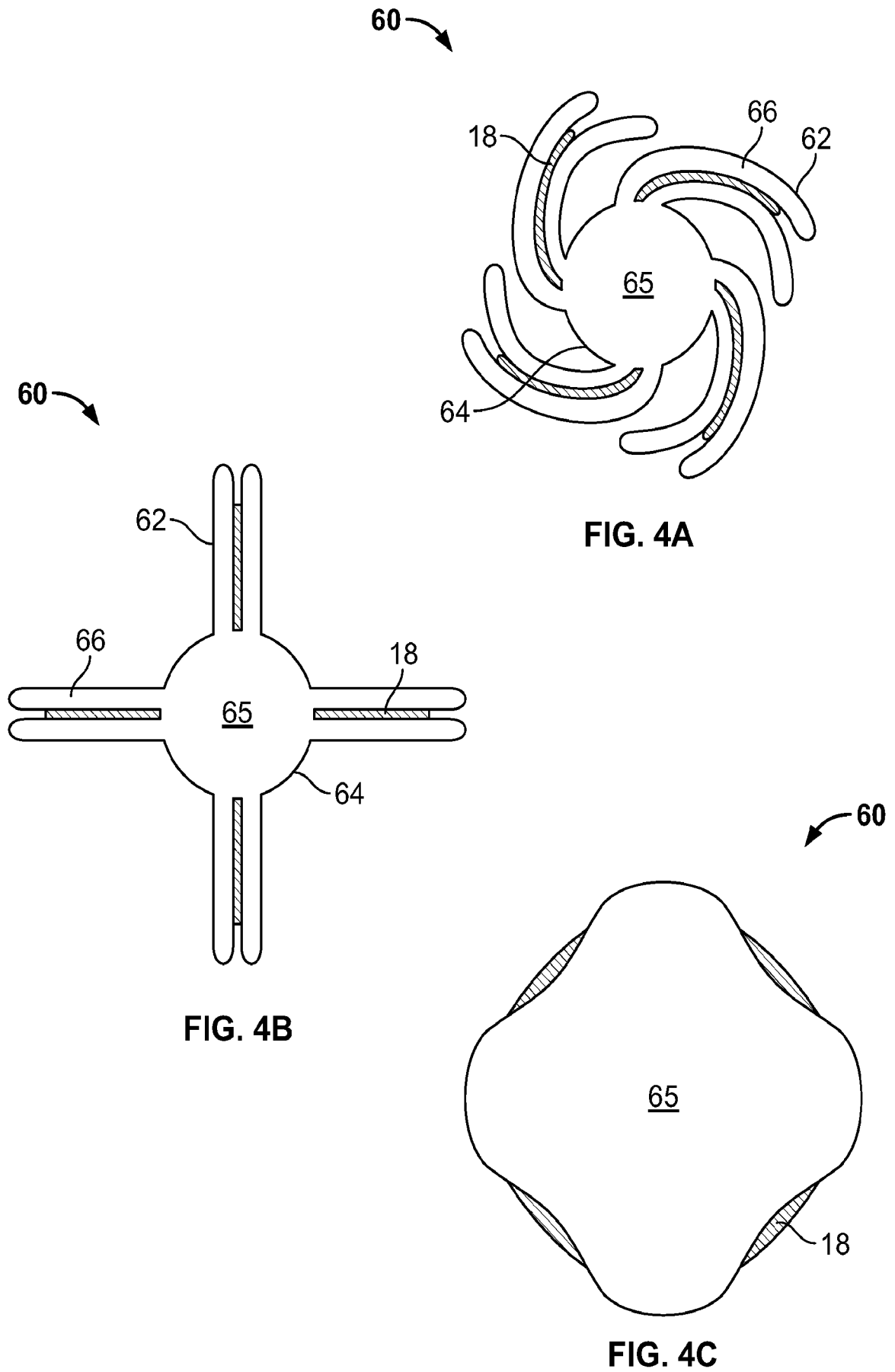

FIG. 3B





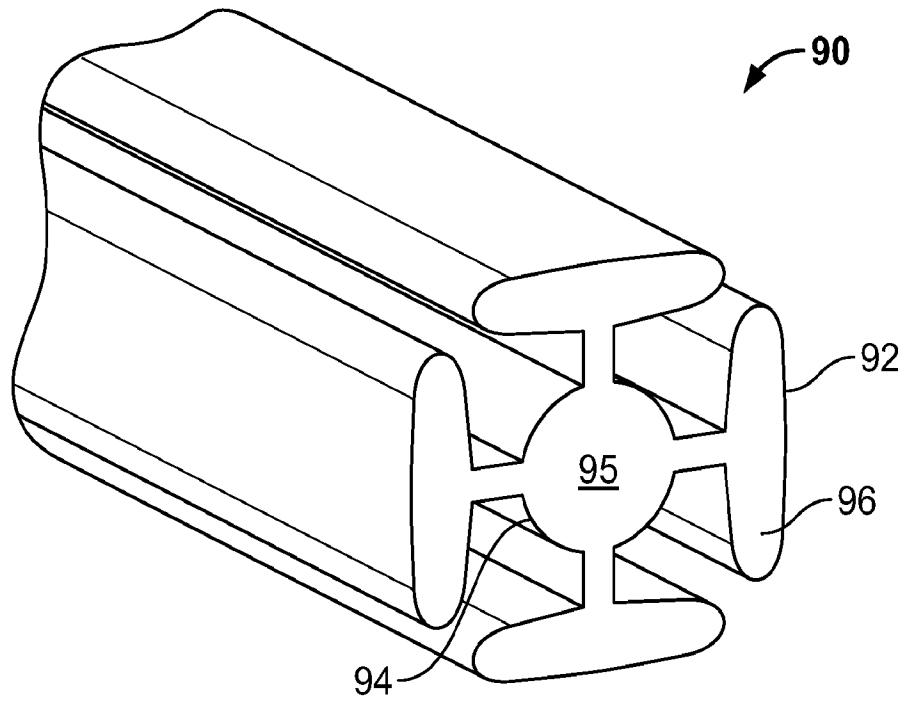

FIG. 5A

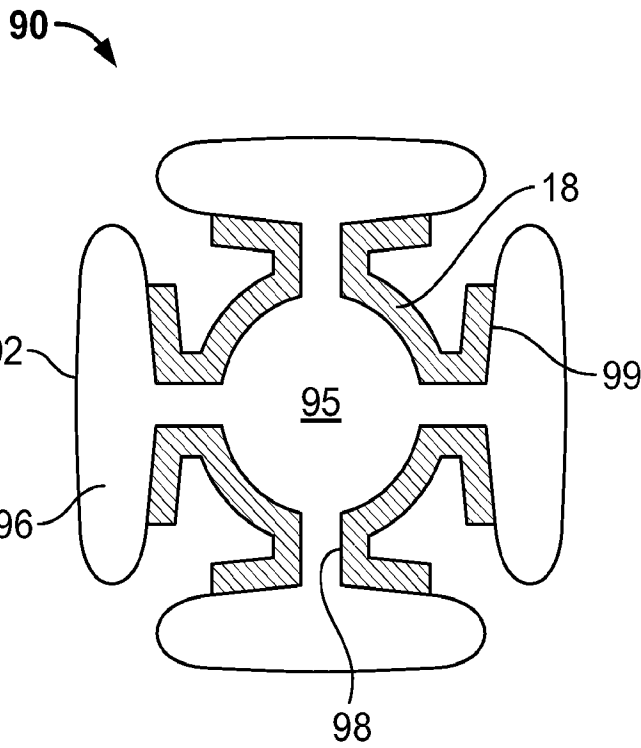

FIG. 5B

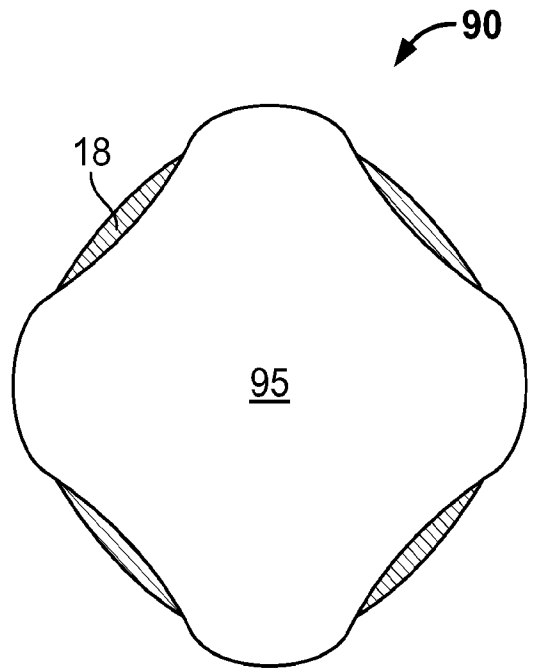

FIG. 5C

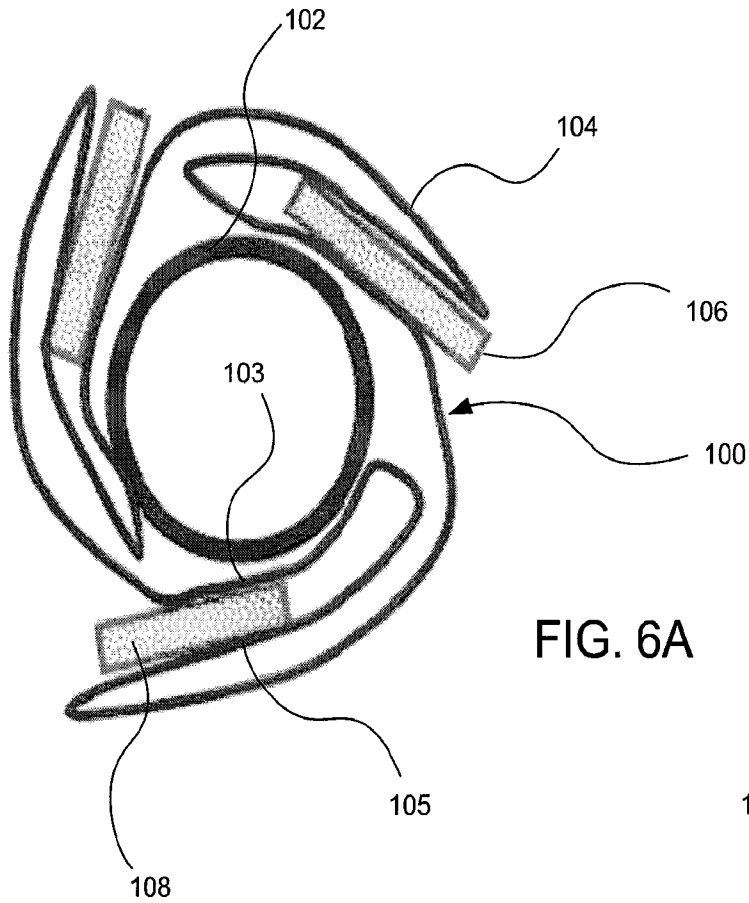

FIG. 6A

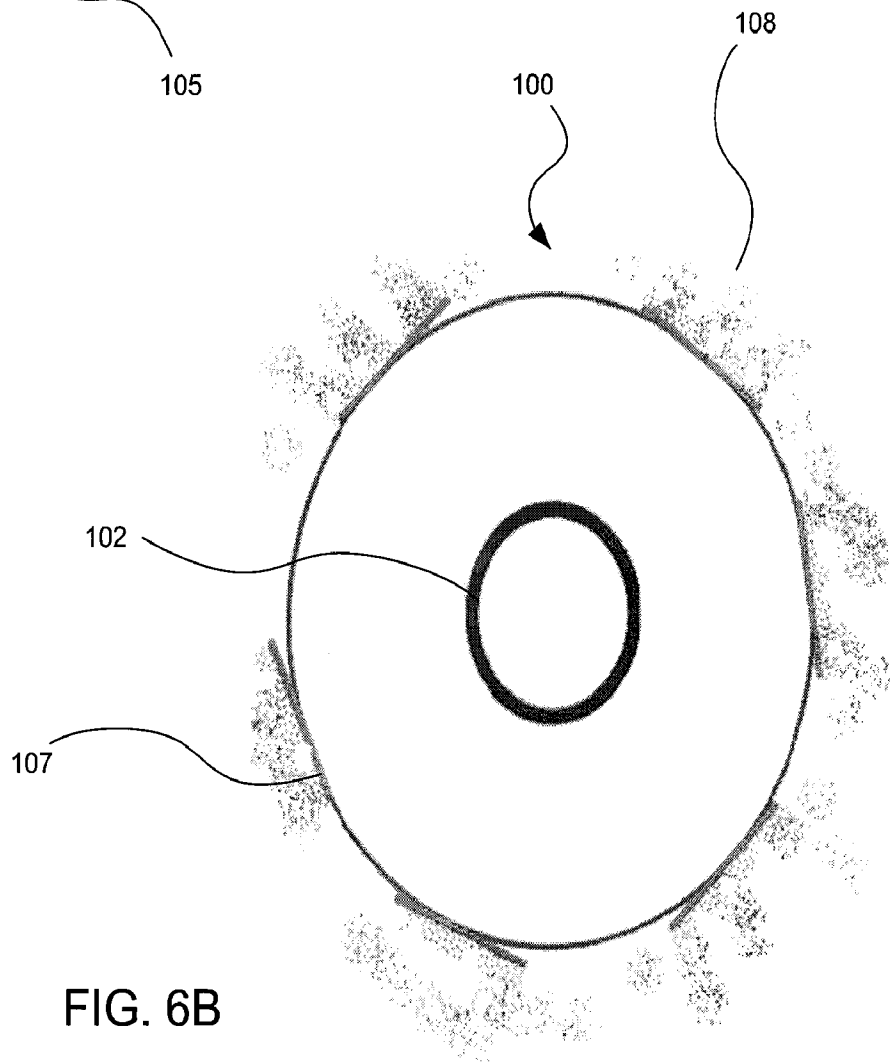

FIG. 6B

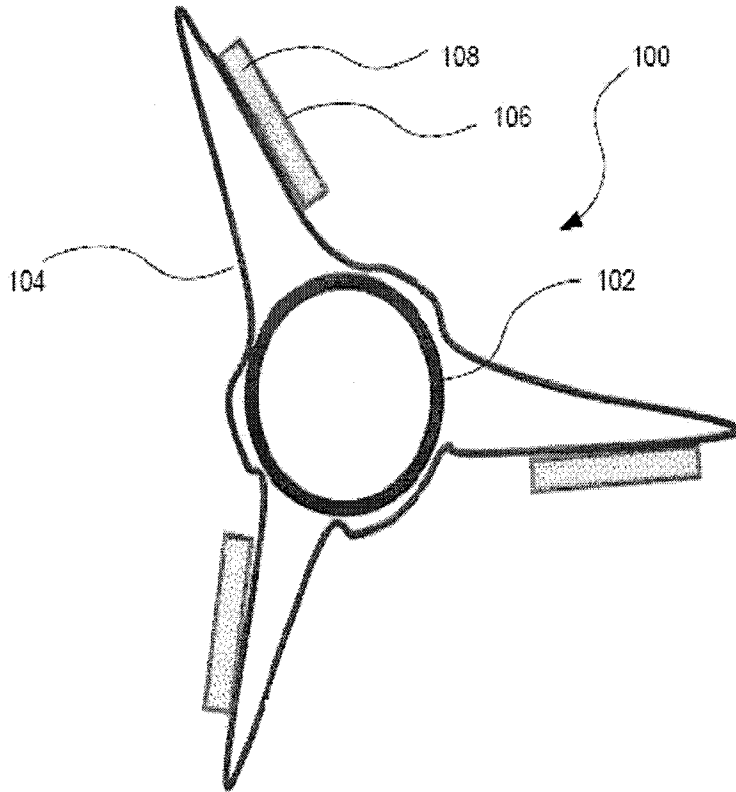

FIG. 7

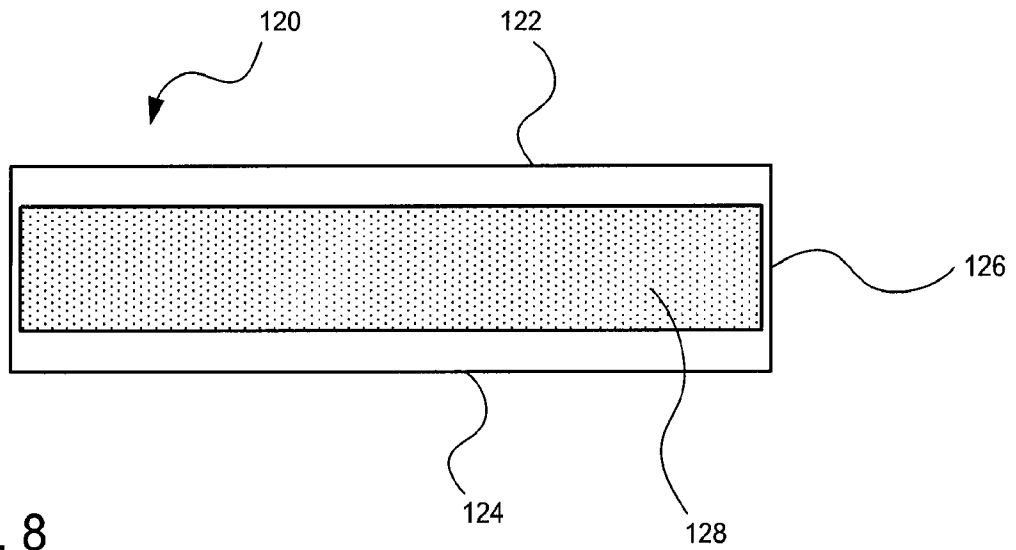

FIG. 8

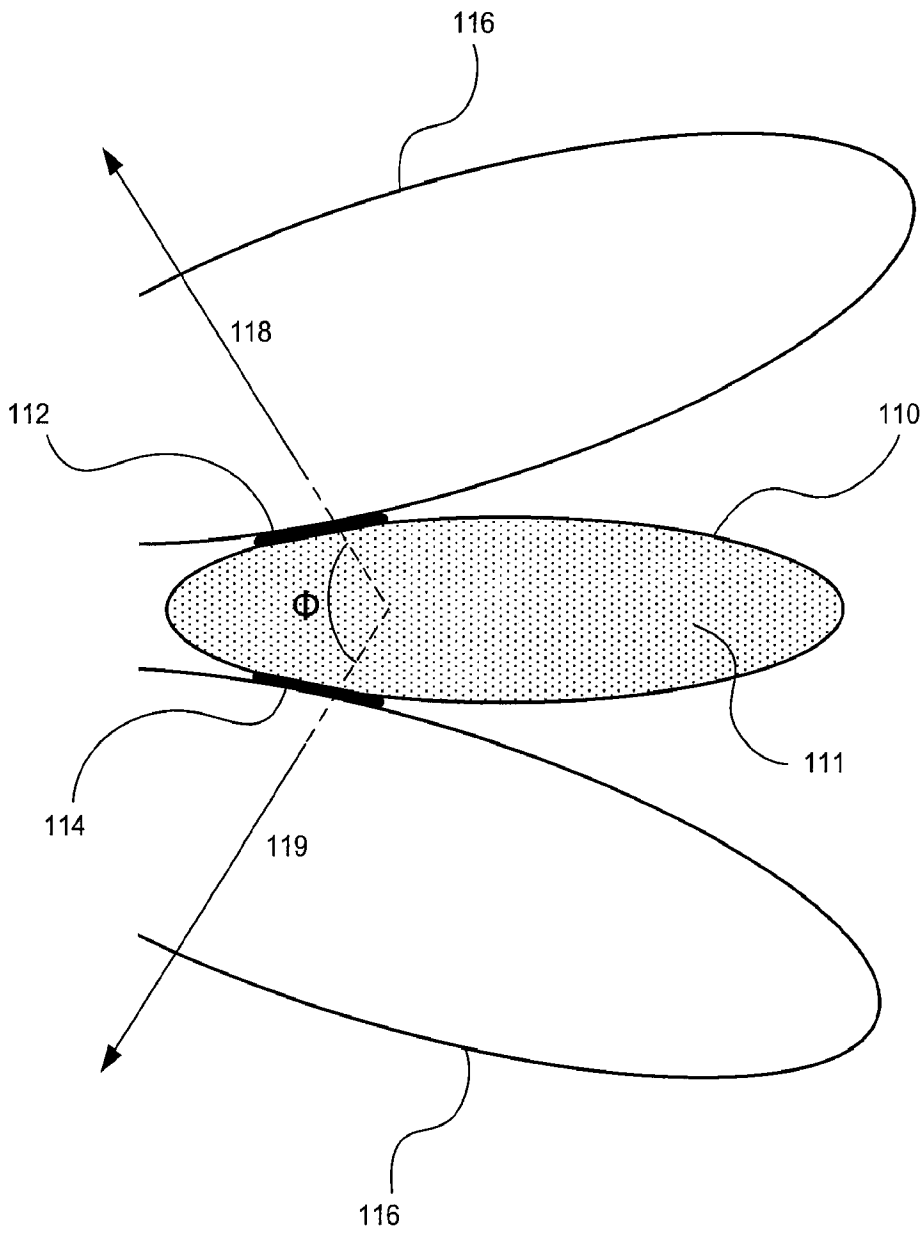

FIG. 9

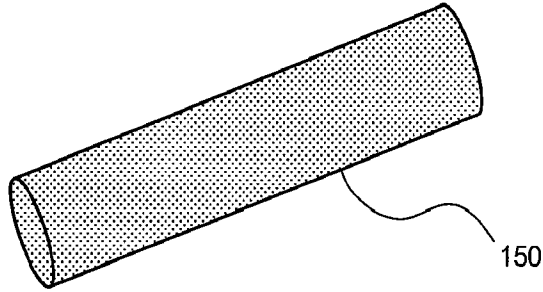

FIG. 10

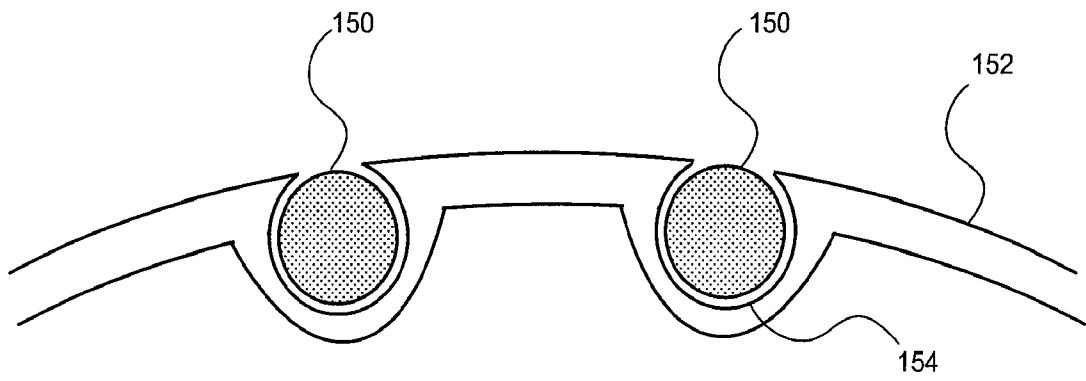

FIG. 11A

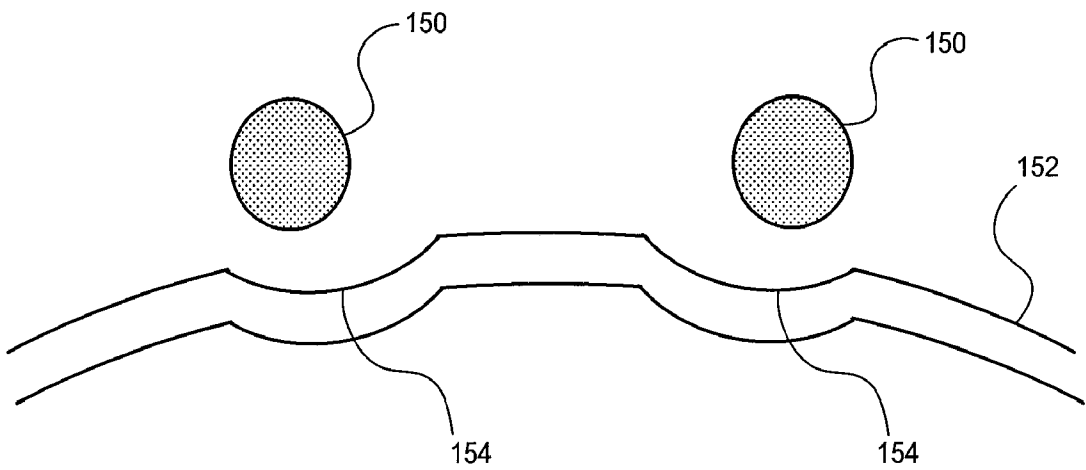

FIG. 11B

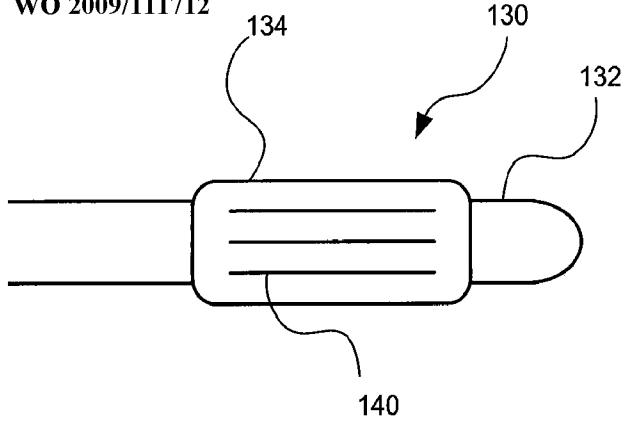

FIG. 12A

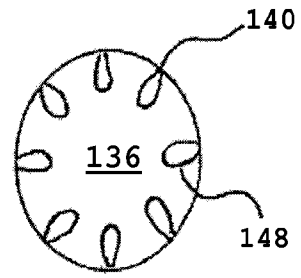

FIG. 12B

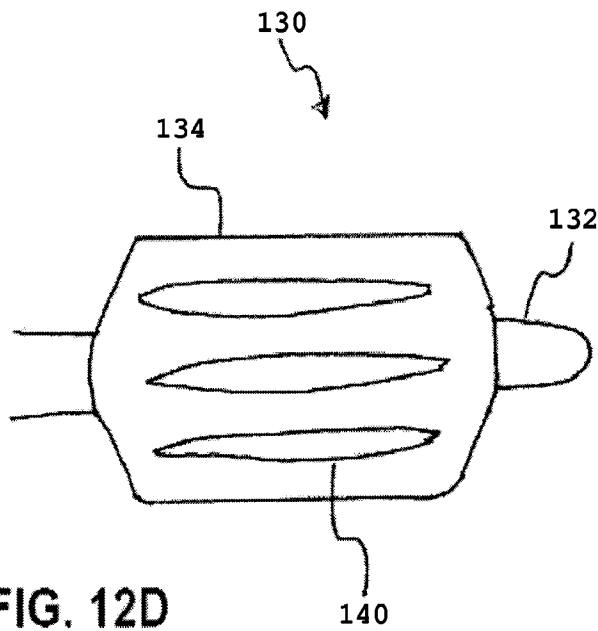

FIG. 12D

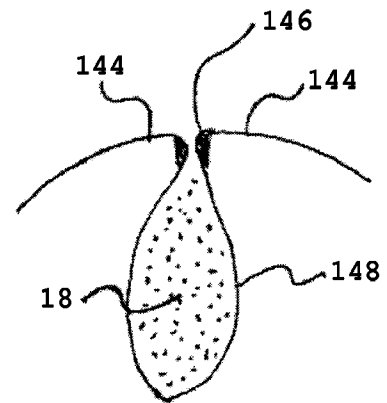

FIG. 12C

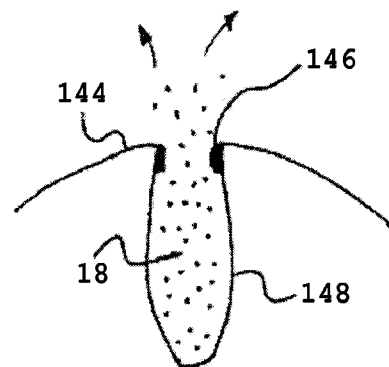

FIG. 12E

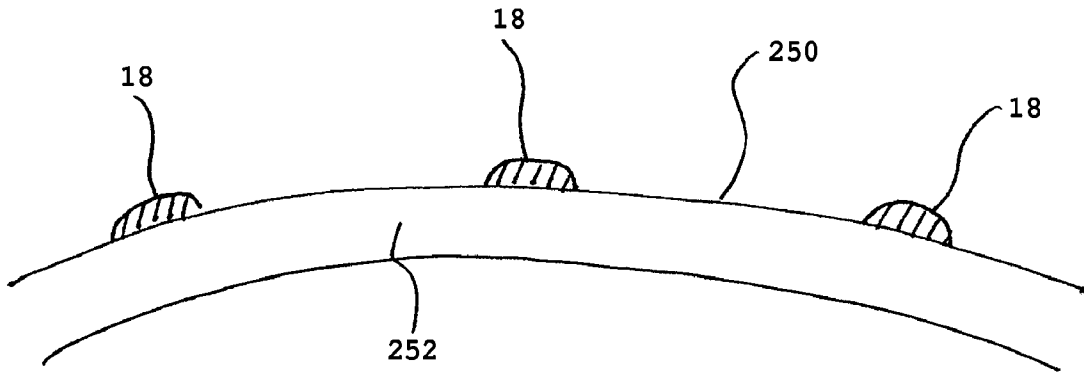

FIG. 13A

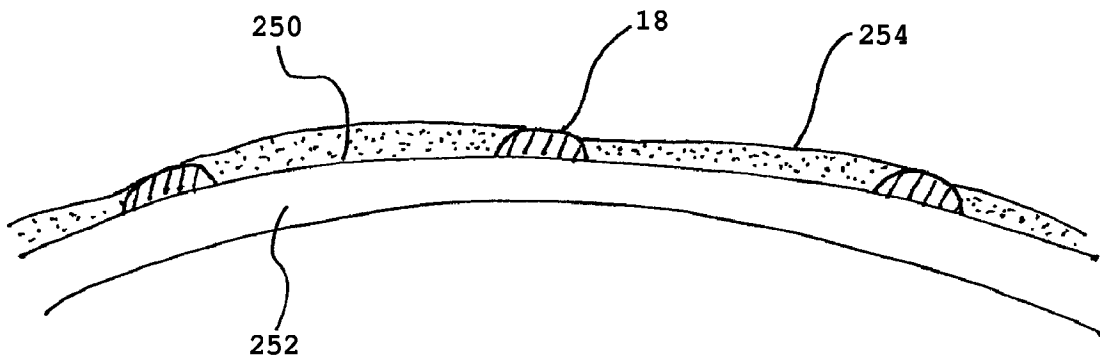

FIG. 13B

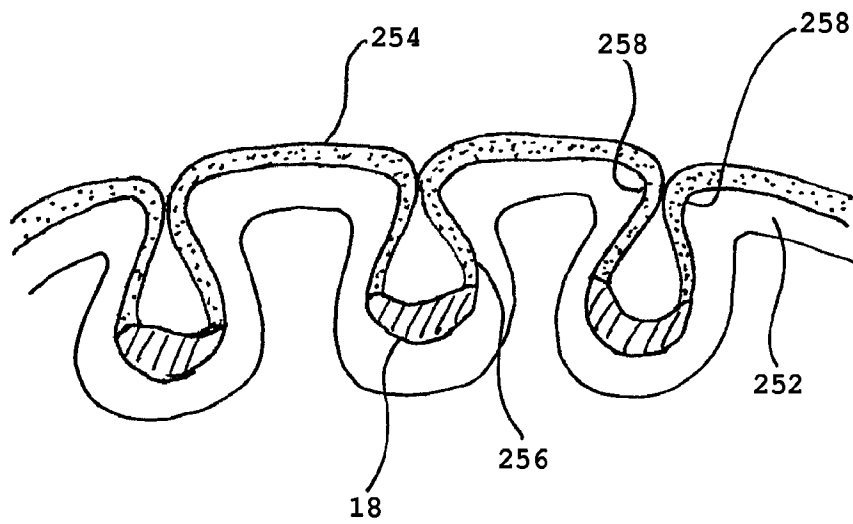

FIG. 13C

**INTERNATIONAL SEARCH REPORT**

International application No  
PCT/US2009/036354

**A. CLASSIFICATION OF SUBJECT MATTER**  
INV. A61M25/10 A61L29/00

According to International Patent Classification (IPC) or to both national classification and IPC

**B. FIELDS SEARCHED**

Minimum documentation searched (classification system followed by classification symbols)  
A61M

Documentation searched other than minimum documentation to the extent that such documents are included in the fields searched

Electronic data base consulted during the international search (name of data base and, where practical, search terms used)  
EPO-Internal, WPI Data

**C. DOCUMENTS CONSIDERED TO BE RELEVANT**

Category*	Citation of document, with indication, where appropriate, of the relevant passages	Relevant to claim No.
X	WO 2007/117755 A (MEDTRONIC VASCULAR INC [US]; BERGLUND JOSEPH [US]) 18 October 2007 (2007-10-18)	1-3,9,19
Y	page 5, line 25 - page 12, line 5; figures 1-6	10,11
X	EP 1 062 966 A (TERUMO CORP [JP]) 27 December 2000 (2000-12-27) paragraphs [0013] - [0047]; figures 1,8,9	1,6-9
X	WO 2007/090385 A (BRAUN MELSUNGEN AG [DE]; VON HOLST ARMIN [DE]; HEITZMANN CHRISTOPH [DE]) 16 August 2007 (2007-08-16)	1-3,9,19
Y	the whole document	4,5,11
	----- -/--	

Further documents are listed in the continuation of Box C.

See patent family annex.

\* Special categories of cited documents:

- "A" document defining the general state of the art which is not considered to be of particular relevance
- "E" earlier document but published on or after the international filing date
- "L" document which may throw doubts on priority claim(s) or which is cited to establish the publication date of another citation or other special reason (as specified)
- "O" document referring to an oral disclosure, use, exhibition or other means
- "P" document published prior to the international filing date but later than the priority date claimed

- "T" later document published after the international filing date or priority date and not in conflict with the application but cited to understand the principle or theory underlying the invention
- "X" document of particular relevance; the claimed invention cannot be considered novel or cannot be considered to involve an inventive step when the document is taken alone
- "Y" document of particular relevance; the claimed invention cannot be considered to involve an inventive step when the document is combined with one or more other such documents, such combination being obvious to a person skilled in the art.
- "&" document member of the same patent family

Date of the actual completion of the international search

13 May 2009

Date of mailing of the international search report

02/07/2009

Name and mailing address of the ISA/

European Patent Office, P.B. 5818 Patentlaan 2  
NL - 2280 HV Rijswijk  
Tel. (+31-70) 340-2040,  
Fax: (+31-70) 340-3016

Authorized officer

Jameson, Patricia



## INTERNATIONAL SEARCH REPORT

International application No

PCT/US2009/036354

C(Continuation). DOCUMENTS CONSIDERED TO BE RELEVANT

Category*	Citation of document, with indication, where appropriate, of the relevant passages	Relevant to claim No.
X	WO 94/23787 A (RAMMLER DAVID H [US]) 27 October 1994 (1994-10-27) page 6, line 22 - page 12, line 21; figures 1-13	1,2,9
X A Y	US 5 893 840 A (HULL VINCENT W [US] ET AL) 13 April 1999 (1999-04-13) the whole document	19,20 1 11
X A Y	DE 203 21 514 U1 (BAYER SCHERING PHARMA AG [DE]) 18 October 2007 (2007-10-18) the whole document	1,9 6-8 2-5
Y	WO 2005/113058 A (MEDTRONIC VASCULAR INC [US]) 1 December 2005 (2005-12-01) abstract; figure 3 paragraph [0043]	4
Y	WO 2008/021019 A (GORE ENTERPRISE HOLDINGS INC [US]; ESKAROS SHERIF [US]; HOUGHTON MICHA) 21 February 2008 (2008-02-21) page 3, line 1 - page 4, line 31; figures 1-4	5,10
Y	US 5 141 494 A (DANFORTH JOHN W [US] ET AL) 25 August 1992 (1992-08-25) abstract; figure 4e	11
A Y	US 2004/215227 A1 (MCMORROW DAVID [IE] ET AL) 28 October 2004 (2004-10-28) cited in the application abstract; figures 1-30	1 2-5
A	WO 2007/055732 A (BOSTON SCIENT SCIMED INC [US] BOSTON SCIENT LTD [BB]) 18 May 2007 (2007-05-18) page 5, line 23 - page 6, line 34; figures 1-11 page 10, lines 4-29	1,19
A	WO 2006/042260 A (BOSTON SCIENT SCIMED INC [US]; HOLMAN THOMAS J [US]; WEBER JAN [US]; S) 20 April 2006 (2006-04-20) paragraphs [0067] - [0077]; compounds 5A-6C	1,19
A	WO 96/00597 A (GEN SURGICAL INNOVATIONS INC [US]) 11 January 1996 (1996-01-11) abstract; figures 5,6	1,10

# INTERNATIONAL SEARCH REPORT

International application No.  
PCT/US2009/036354

## Box No. II Observations where certain claims were found unsearchable (Continuation of item 2 of first sheet)

This international search report has not been established in respect of certain claims under Article 17(2)(a) for the following reasons:

1.  Claims Nos.:  
because they relate to subject matter not required to be searched by this Authority, namely:
  
2.  Claims Nos.:  
because they relate to parts of the international application that do not comply with the prescribed requirements to such an extent that no meaningful international search can be carried out, specifically:
  
3.  Claims Nos.:  
because they are dependent claims and are not drafted in accordance with the second and third sentences of Rule 6.4(a).

## Box No. III Observations where unity of invention is lacking (Continuation of item 3 of first sheet)

This International Searching Authority found multiple inventions in this international application, as follows:

see additional sheet

1.  As all required additional search fees were timely paid by the applicant, this international search report covers allsearchable claims.
  
2.  As all searchable claims could be searched without effort justifying an additional fees, this Authority did not invite payment of additional fees.
  
3.  As only some of the required additional search fees were timely paid by the applicant, this international search report covers only those claims for which fees were paid, specifically claims Nos.:
  
4.  No required additional search fees were timely paid by the applicant. Consequently, this international search report is restricted to the invention first mentioned in the claims; it is covered by claims Nos.:

see annex

### Remark on Protest

- The additional search fees were accompanied by the applicant's protest and, where applicable, the payment of a protest fee.
- The additional search fees were accompanied by the applicant's protest but the applicable protest fee was not paid within the time limit specified in the invitation.
- No protest accompanied the payment of additional search fees.

## FURTHER INFORMATION CONTINUED FROM PCT/ISA/ 210

This International Searching Authority found multiple (groups of) inventions in this international application, as follows:

## 1. claims: 1-11, 19-20

A medical device comprising:

a catheter;  
a balloon mounted on the catheter, the balloon having a main body and at least one lobe that forms a fold, wherein the fold opens upon expansion of the balloon; and  
a therapeutic agent disposed within the fold, wherein the opening of the fold upon expansion of the balloon promotes the release of the therapeutic agent.

and

A medical device comprising:

a catheter;  
a balloon mounted on the catheter, the balloon having a plurality of folds that open upon expansion of the balloon;  
and  
a plurality of discrete bulk masses of therapeutic agent disposed within the folds, wherein the bulk masses of therapeutic agent are released upon opening of the folds.

---

## 2. claims: 12-18

A medical device comprising:

a catheter;  
a balloon mounted on the catheter, the balloon comprising at least one lobe that forms a fold, wherein the fold opens upon expansion of the balloon; and  
a packet disposed within the fold, the packet containing a therapeutic agent and having a first attachment site where the packet is attached to the lobe and a second attachment site where the packet is attached to an adjacent surface of the balloon.

---

## INTERNATIONAL SEARCH REPORT

Information on patent family members

International application No

PCT/US2009/036354

Patent document cited in search report	Publication date	Patent family member(s)	Publication date
WO 2007117755 A	18-10-2007	EP 1988960 A2 US 2007191811 A1	12-11-2008 16-08-2007
EP 1062966 A	27-12-2000	AT 274966 T DE 60013362 D1 DE 60013362 T2 JP 2001009037 A	15-09-2004 07-10-2004 08-09-2005 16-01-2001
WO 2007090385 A	16-08-2007	DE 112007000906 A5 EP 1981559 A2 US 2009054837 A1	15-01-2009 22-10-2008 26-02-2009
WO 9423787 A	27-10-1994	NONE	
US 5893840 A	13-04-1999	NONE	
DE 20321514 U1	18-10-2007	NONE	
WO 2005113058 A	01-12-2005	AT 402729 T EP 1753497 A1 ES 2310357 T3 JP 2008500142 T	15-08-2008 21-02-2007 01-01-2009 10-01-2008
WO 2008021019 A	21-02-2008	AU 2007284917 A1 CA 2660017 A1 EP 2049182 A2 US 2008097300 A1	21-02-2008 21-02-2008 22-04-2009 24-04-2008
US 5141494 A	25-08-1992	NONE	
US 2004215227 A1	28-10-2004	AT 381951 T AU 2003205375 A1 CA 2475673 A1 DE 60318305 T2 EP 1490136 A1 ES 2300561 T3 JP 2005518880 T WO 03074116 A1 US 2003163157 A1	15-01-2008 16-09-2003 12-09-2003 11-12-2008 29-12-2004 16-06-2008 30-06-2005 12-09-2003 28-08-2003
WO 2007055732 A	18-05-2007	CA 2629901 A1 EP 1954340 A1 JP 2009515647 T US 2007112300 A1	18-05-2007 13-08-2008 16-04-2009 17-05-2007
WO 2006042260 A	20-04-2006	CA 2591389 A1 EP 1802368 A2 JP 2008515567 T US 2006079836 A1	20-04-2006 04-07-2007 15-05-2008 13-04-2006
WO 9600597 A	11-01-1996	AT 262948 T AU 2916295 A CA 2193977 A1 DE 69532807 D1 DE 69532807 T2 EP 0767686 A1 ES 2218549 T3 JP 2966103 B2	15-04-2004 25-01-1996 11-01-1996 06-05-2004 17-03-2005 16-04-1997 16-11-2004 25-10-1999

# INTERNATIONAL SEARCH REPORT

Information on patent family members

International application No

PCT/US2009/036354

Patent document cited in search report	Publication date	Patent family member(s)	Publication date
WO 9600597	A	JP 10502272 T US 5601589 A US 5690668 A	03-03-1998 11-02-1997 25-11-1997