

(19) World Intellectual Property Organization
International Bureau



(43) International Publication Date
5 April 2001 (05.04.2001)

PCT

(10) International Publication Number
WO 01/24314 A1

(51) International Patent Classification⁷: H01Q 9/04, 5/00

(21) International Application Number: PCT/GB00/03746

(22) International Filing Date:
29 September 2000 (29.09.2000)

(25) Filing Language: English

(26) Publication Language: English

(30) Priority Data:
9923174.8 30 September 1999 (30.09.1999) GB

(71) Applicant (for all designated States except US):
HARADA INDUSTRIES (EUROPE) LIMITED
[GB/GB]; Bell Heath Way, Woodgate Business Park,
Clapgate Lane, Birmingham B32 3BZ (GB).

(72) Inventors; and

(75) Inventors/Applicants (for US only): **LANGLEY,**

Richard, Jonathan [GB/GB]; Harada European Technology Centre, Research and Development Building, University of Kent, Canterbury, Kent CT2 7PD (GB).
VIRATELLE, Didier [FR/GB]; Harada European Technology Centre, Research and Development Building, University of Kent, Canterbury, Kent CT2 7PD (GB).

(74) Agents: **MOIR, Michael, Christopher** et al.; Mathys & Squire, 100 Gray's Inn Road, London WC1X 8AL (GB).

(81) Designated States (*national*): AE, AG, AL, AM, AT, AU, AZ, BA, BB, BG, BR, BY, CA, CH, CN, CU, CZ, DE, DK, DZ, EE, ES, FI, GB, GD, GE, GH, GM, HR, HU, ID, IL, IN, IS, JP, KE, KG, KP, KR, KZ, LC, LK, LR, LS, LT, LU, LV, MD, MG, MK, MN, MW, MX, MZ, NO, NZ, PL, PT, RO, RU, SD, SE, SG, SI, SK, SL, TJ, TM, TR, TT, UA, UG, US, UZ, VN, YU, ZA, ZW.

(84) Designated States (*regional*): ARIPO patent (GH, GM, KE, LS, MW, MZ, SD, SL, SZ, TZ, UG, ZW), Eurasian patent (AM, AZ, BY, KG, KZ, MD, RU, TJ, TM), European patent (AT, BE, CH, CY, DE, DK, ES, FI, FR, GB, GR, IE,

[Continued on next page]

(54) Title: DUAL-BAND MICROSTRIP ANTENNA

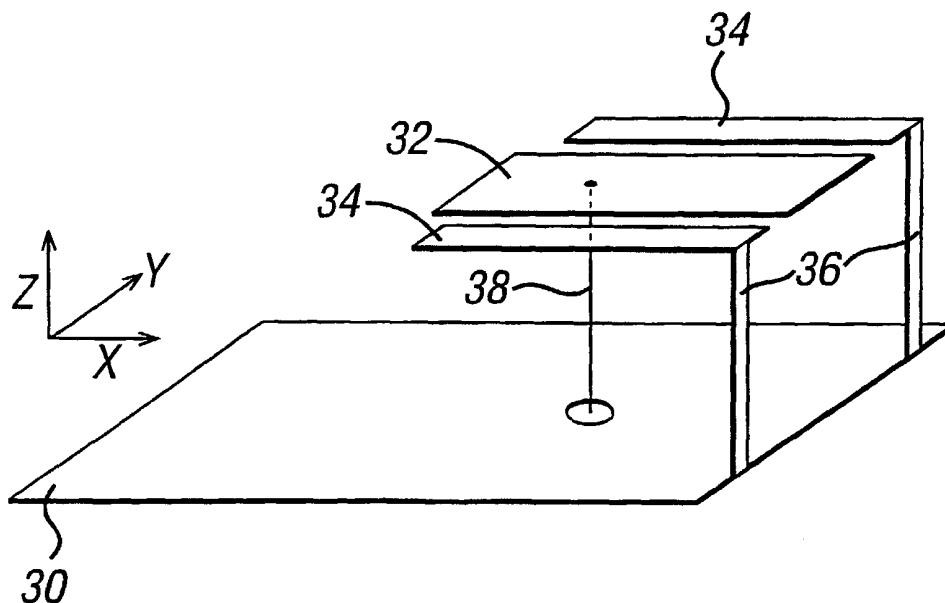

(57) Abstract: A dual-band microstrip antenna has a ground plate and also has a central patch positioned between a pair of side patches. The antenna has a single signal feedline, connected to the central patch, and the side patches are shorted to the ground element. Conductive surfaces of the ground plate and patches that carry surface current from signal radiation are contoured such that only portions of conductive surfaces that carry more than a negligible amount of the surface current are retained. The antenna has a reduced weight and improved bandwidth over conventional antennas that operate in the 925 MHz and 1800 MHz ranges.



WO 01/24314 A1



IT, LU, MC, NL, PT, SE), OAPI patent (BF, BJ, CF, CG, CI, CM, GA, GN, GW, ML, MR, NE, SN, TD, TG).

For two-letter codes and other abbreviations, refer to the "Guidance Notes on Codes and Abbreviations" appearing at the beginning of each regular issue of the PCT Gazette.

Published:

— *With international search report.*

- 1 -

DUAL-BAND MICROSTRIP ANTENNA

The invention relates to a dual-band antenna, and provides a dual-band microstrip antenna that has ground and patch elements configured such that the contour of the surface areas of the elements substantially corresponds to the pattern of induction currents created in the elements by signals in the dual bands.

One important use of dual-band microstrip antennas is in mobile communication systems. A common configuration for an antenna in such use is the inverted-F geometry which is described in two articles by Zi Dong Liu and Peter S. Hall. The first article is "Dual-band antenna for hand held portable telephones", Electronics Letters, Vol. 32, No. 7, pp. 609-610 (March 1996), and the second (and more comprehensive) is "Dual-Frequency Planar Inverted-F Antenna", IEEE Transactions on Antennas and Propagation, Vol. 45, pp. 1451-1457 (October 1997).

Liu and Hall describe two dual-frequency-band antenna configurations, one with a single input port and the other with two input ports. The two-port antenna consists of two co-planar radiating elements -- the first one being rectangular and the second one being L-shaped and having two sides adjacent the first one. The rectangular element is for 1.8 GHz signals, while the L-shaped element is for 0.9 GHz signals. This configuration of dual-band antenna is about the same size as a single-band inverted-F antenna for 0.9 GHz signals. Both the rectangular element and the L-shaped element have one end shorted to the ground plane. Because the two radiating elements are not connected, the coupling between the two antennas is small and only due to fringe-field interaction. A variation has a single input port connected to an intermediate point of connection between the rectangular element and the L-shaped element. Although it has the advantage of using only a single input port, this arrangement has the drawback that the coupling

- 2 -

between the rectangular element and the L-shaped element is increased.

As with the variation of the dual-frequency-band antenna of Lui and Hall, the antenna of the subject invention utilizes multiple radiating elements with a single input port; unlike the antenna of Lui and Hall, however, the multiple radiating elements of the subject antenna are not connected. The antenna of the subject invention has the advantages over that of Lui and Hall of having only two shorting points and a much-increased bandwidth. In addition, portions of the radiating and ground elements that carry little or no surface current are removed, resulting in weight reduction and a degree of transparency. A further advantage is that the dual-band antenna of the invention is capable of being mass-produced at low cost using flexible printed circuit board.

In one form, the invention is a dual-band microstrip that includes a ground member and patch means having discrete first and second portions and which is in a generally parallel spaced relationship with the ground member. First and second resonant frequency ranges being defined by the electromagnetic interaction between the patch means and the ground member. Conduction surfaces of the portions of the patch means are shaped so as to substantially correspond to current paths that signals within the first and second resonant frequency ranges would induce in the conduction surfaces without such shaping. Conduction surfaces of the ground member may be shaped in a similar manner.

In the antenna, sides and one end of the patch means may be in respective alignment with sides and one end of the ground member. The first portion of the patch means may be a first patch, and the second portion of the patch means may be a pair of second patches each having a side adjacent a respective opposite side of the first patch. One end of each first and second patch corresponds to the

- 3 -

one end of the patch means. An antenna signal feedline is connected to a generally central position on the first patch, and a shorting member extends from each second patch to the ground member at a point proximate the one
5 end of the second patch and the ground member.

Each second patch may have a length approximating the length of the first patch, and a width approximating one-half the width of the first patch. The first patch may be generally configured as an 'H', with the sides of the
10 first patch corresponding to side members of the 'H'.

In a first construction, the conducting surfaces of the ground member may be configured as a hollow generally rectangular structure, with a cross-piece extending between the sides of the structure at a projection of the
15 position at which the antenna signal feedline connects to the first patch. In a second construction, the conducting surfaces of the ground member may be defined by two side members and an other end member and with a cross-piece extending between the two side members at a projection of
20 the position at which the antenna signal feedline connects to the first patch. In the second construction, extensions of the side members of the first patch extend from the one end of the patch means to the plane of the ground member and then in the plane of the ground member
25 for a part of the distance toward the cross-piece.

A coaxial cable may be attached to the antenna such that a ground portion of the cable is connected to the cross-piece of the ground member, and such that a signal feed portion of the cable defines the antenna signal
30 feedline attached to the first patch.

The antenna may be formed from printed circuit board having a conductive layer on one side. The conducting surfaces of the ground member are formed by removing portions of a conductive layer on the one side of a first
35 segment of the circuit board. The conducting surfaces of the patch means are formed by removing portions of the

- 4 -

conductive layer on the one side of a second segment of the board. The first and second segments of the circuit board are then mounted in parallel spaced relationship. In the first construction, shorting members are applied
5 between the ground member and the second patches proximate the one end of the ground member and the second patches, whereas in the second construction, shorting members are applied between the one end of the ground member and the one end of the first and second patches.

10 In another form, the invention is a dual-band microstrip antenna that includes a ground member and first and second portions of a patch means. The patch means is in a generally parallel spaced relationship with the ground member. First and second resonant frequency ranges are
15 defined by the electromagnetic interaction between the patch means and the ground member. Sides and one end of the patch means are in respective alignment with sides and one end of the ground member. The first portion of the patch means is a first patch, and the second portion of
20 the patch means is a pair of second patches each positioned adjacent a respective opposite side of the first patch. One end of each first and second patch corresponds to one end of the patch means. An antenna signal feedline is connected to a generally central position on the first
25 patch, and a shorting member extends from each second patch to the ground member at a point proximate the one end of the second patch and the ground member.

The invention will next be more fully described by way of example only, by means of preferred embodiments,
30 utilizing the accompanying drawings, in which:

Figure 1 is a perspective view of a typical prior art inverted-F antenna adapted to operate over a single frequency band;

Figure 2 is a perspective view of an embodiment of
35 the dual-band microstrip antenna of the invention;

Figure 3 is an illustration of the surface currents

- 5 -

on the antenna of Figure 2 at a radiating frequency of 925 Megahertz;

Figure 4 is an illustration of the surface currents on the antenna of Figure 2 at a radiating frequency of
5 1800 Megahertz;

Figure 5 is a perspective view of another embodiment of the microstrip antenna of the invention, the antenna being similar to Figure 2 but having excess metal removed from the ground plate and the patch plates;

10 Figure 6 is a further embodiment of the microstrip antenna of the invention, the antenna being a slightly-modified version of the antenna of Figure 5;

Figure 7 is a top view of a ground plate of the further embodiment of the antenna of the invention;

15 Figure 8 is a top view of the patches of the further embodiment of the antenna of the invention;

Figure 9 is a side or cross view of the further embodiment of the microstrip antenna of the invention;

20 Figure 10 is a graph illustrating the return loss for the antennas shown in Figures 2 and 5;

Figure 11 is an illustration of the radiation patterns obtained in the YZ plane (based on the axes orientation shown in Figure 2) for the antenna of the embodiment shown in Figures 6 to 9, measured at 925 MHz
25 and 1800 MHz;

Figure 12 is an illustration of the radiation patterns obtained in the XZ plane (based on the direction of axes shown in Figure 2) for the antenna of the embodiment shown in Figures 6 to 9, measured at 925 MHz
30 and 1800 MHz; and,

Figure 13 is an illustration of a further embodiment of the dual-band antenna of the invention, that antenna having a wrap-around first patch.

Referring first to Figure 1, the typical prior art
35 inverted-F antenna operating on a single frequency band has a ground plate 20 of length L that is connected to a

- 6 -

patch plate 22 of length P through a shorting plate 24 of height H; the three plates 20, 22 and 24 all have a width W. A feed pin 26, which is an extension of the centre wire of a coaxial cable (not shown) that has its ground wire connected to ground plate 20, connects to a central position on the patch plate 22. The length P of patch plate 22 approximates one-quarter wavelength at the mid-range of the frequency band of the antenna. The metallic surface of ground plate 20 may be provided by the metallic side of a portable telephone or other device on which the antenna is used.

Prior to removal of metal from the ground plate and the radiating patches, an embodiment of the dual-band microstrip antenna has, as shown in Figure 2, a ground plate 30, a central patch plate 32, a pair of side patch plates 34, and a pair of shorting strips 36 each of which connects a respective side patch plate 34 to the ground plate 30. A feed pin 38, which as with feed pin 26 in Figure 1 is an extension of the centre wire of a coaxial cable (not shown), connects to a central position on the central patch plate 32; a ground wire of the coaxial cable is connected to the ground plate 30. The connection point of feed pin 38 and the lengths of patch plates 32 and 34 are experimentally adjusted until the desired antenna bandwidths and a 50-ohm impedance match with the coaxial cable are obtained. As shown, the side patch plates 34 are each narrower and slightly shorter than the central patch plate 32. Figure 2 illustrates the orientation of the antenna with respect to a X-Y-Z co-ordinate system that has application to the radiation patterns shown in Figures 11 and 12.

When the surface currents on conductive material of the antenna of Figure 2 were measured in the frequency ranges of 925 MHz (Figure 3) and 1800 MHz (Figure 4), it was found that little or no surface current was present on large areas of the conductive material at either frequency

- 7 -

range. Those areas of the conductive material therefore contribute to the weight but not to the performance of the antenna, and may be removed. Removal of that material has also been found to improve the bandwidth.

5 Figure 5 illustrates the antenna of Figure 2 after removal of the conductive material that was found to carry little or no surface current in the two frequency bands of interest. A central portion of ground plate 30 has been removed except for a cross-piece 40 to which a signal
10 carrier, such as a coaxial cable, is connected. Two central sections of the central patch plate 32 have also been removed -- giving the central patch plate 32 an 'H' configuration.

The embodiment of the antenna in Figure 6 differs
15 from the one shown in Figure 5 in the type and placement of the shorting means; except for the shorting means, the numbering of parts in both is the same. The shorting means differs between the embodiments of Figures 5 and 6 in that each shorting pin 42 in the Figure 6 embodiment is
20 not connected between the end of the ground plate 30 and the end of a respective side patch plate 34, but instead is connected at positions removed from the ends. Each shorting pin 42 extends (as shown in Figures 7 and 8) between a hole 44 on ground plate 30 and a hole 46 on a
25 respective side patch plate 34. The signal feed pin 38 extends through the large hole 48 in cross-piece 40. A top view of the ground conducting plate is shown in Figure 7, and a top view of the patch plates is shown in Figure 8. A side or cross view of the antenna of Figure 6 is
30 shown in Figure 9, in which a connector 50 for connecting a coaxial cable or other signal carrier to the ground plate 30 is shown.

The numbers adjacent the arrows in Figures 7 to 9 represent in millimetres the dimensions of the ground
35 plate 30 and the patch plates 32, 34 in the antenna of this preferred embodiment -- as well as their relative

- 8 -

spacing. The ground plate is 13.5 cm. long and 20 cm. wide, the central patch plate 32 is 86.75 mm. long and 8 mm. wide, and the side patch plates 34 are each 82 mm. long and 3 mm. wide. The width of the spacing between the central patch plate 32 and each side patch plate 34 is 2 mm. Each of the holes 44 and 46, to which the shorting pins 42 connect, is 12 mm. from the end of the respective ground plate 30 and side patch plate 34.

Figure 10 illustrates the difference in return loss between the antennas of Figures 2 and 5. At the two resonant frequencies, the return loss can be seen to be greater in the antenna with metal removed (solid line) than in the antenna without metal removed (dotted line). Measured radiation patterns in the YZ and XZ planes (with reference to the co-ordinate system in Figure 2) for the antenna embodiment of Figures 6 to 9 are shown in Figures 11 and 12, respectively.

Figure 13 illustrates a further preferred embodiment of the antenna of the invention. It differs from the embodiment shown in Figures 6 to 9 in that the central patch plate 32 has a wrap-around configuration in which one end of a hollow ground plate 30 has been removed, and the sides of the central patch plate 32 have been extended across to the plane of the ground plate 30 and then a part of the distance toward the cross-piece 40 in that plane.

While the present invention has been described in its preferred embodiments, it is to be understood that the words which have been used are words of description rather than limitation, and that changes may be made to the invention without departing from its scope as defined by the appended claims.

Each feature disclosed in this specification (which term includes the claims) and/or shown in the drawings may be incorporated into the invention independently of other disclosed and/or illustrated features.

The text of the abstract filed herewith is repeated

- 9 -

here as part of the specification.

A dual-band microstrip antenna has a ground plate and also has a central patch positioned between a pair of side patches. The antenna has a single signal feedline,
5 connected to the central patch, and the side patches are shorted to the ground element. Conductive surfaces of the ground plate and patches that carry surface current from signal radiation are contoured such that only portions of
10 conductive surfaces that carry more than a negligible amount of the surface current are retained. The antenna has a reduced weight and improved bandwidth over conventional antennas that operate in the 925 MHz and 1800 MHz ranges.

- 10 -

CLAIMS:

1. A dual-band microstrip antenna comprising:
a ground member; and,
patch means having discrete first and second portions
and which is in a generally parallel spaced relationship
5 with the ground member, first and second resonant
frequency ranges being defined by the electromagnetic
interaction between the patch means and the ground member;
wherein conduction surfaces of the portions of the patch
means are shaped so as to substantially correspond to
10 current paths that signals within the first and second
resonant frequency ranges would induce in the conduction
surfaces without such shaping.

2. An dual-band microstrip antenna as in claim 1,
wherein conduction surfaces of the ground member are
shaped so as to substantially correspond to current paths
that signals within the first and second resonant
frequency ranges would induce in those conduction surfaces
without such shaping.

3. A dual-band microstrip antenna as in claim 1 or
2, wherein the ground member has a rectangular outer
profile and wherein sides and one end of the patch means
are in respective alignment with sides and one end of the
ground member.

4. A dual-band microstrip antenna as in claim 3,
wherein the first portion of the patch means is a first
patch, wherein the second portion of the patch means is a
pair of second patches each positioned adjacent a respec-
5 tive opposite side of the first patch, one end of each
first and second patch corresponding to the one end of the
patch means, wherein an antenna signal feedline is
connected to a generally central position on the first

- 11 -

patch, and wherein a shorting member extends from each
10 second patch to the ground member at a point proximate the
one end of the second patch and the ground member.

5. A dual-band microstrip antenna comprising:
a ground member; and,

first and second portions of a patch means that is in
a generally parallel spaced relationship with the ground
5 member, first and second resonant frequency ranges being
defined by the electromagnetic interaction between the
patch means and the ground member;
wherein sides and one end of the patch means are in
respective alignment with sides and one end of the ground
10 member, wherein the first portion of the patch means is a
first patch and the second portion of the patch means is a
pair of second patches, each second patch having a side
adjacent a respective opposite side of the first patch,
one end of each first and second patch corresponding to
15 the one end of the patch means, wherein an antenna signal
feedline is connected to a generally central position on
the first patch, and wherein a shorting member extends
from each second patch to the ground member at a point
proximate the one end of the second patch and the ground
20 member.

6. A dual-band microstrip antenna as in claim 4 or
5, wherein each second patch has a length approximating
the length of the first patch, and has a width approxi-
mating one-half the width of the first patch.

7. A dual-band microstrip antenna as in claim 6,
wherein the first patch is generally configured as an 'H',
with the sides of the first patch corresponding to side
members of the 'H'.

8. A dual-band microstrip antenna as in claim 4,

- 12 -

wherein the conducting surfaces of the ground member is configured as a hollow generally rectangular structure, with a cross-piece extending between the sides of the structure at a projection of the position at which the antenna signal feedline connects to the first patch.

9. A dual-band microstrip antenna as in claim 7, wherein the conducting surface of the ground member is defined by two side members and an other end member and with a cross-piece extending between the two side members
5 at a projection of the position at which the antenna signal feedline connects to the first patch, and wherein extensions of the side members of the first patch extend from the one end of the patch means to the plane of the ground member and then in the plane of the ground member
10 for a part of the distance toward the cross-piece.

10. A dual-band microstrip antenna as in claim 8 or 9, wherein a coaxial cable is attached to the antenna such that a ground portion of the cable is connected to the cross-piece of the ground member, and such that a signal feed portion of the cable defines the antenna signal feedline attached to the first patch.

11. A dual-band microstrip antenna as in claim 8, wherein the antenna is formed from printed circuit board having a conductive layer on one side, wherein the conducting surfaces of the ground member are formed by
5 removing portions of the conductive layer on the one side of a first segment of the circuit board, wherein the conducting surfaces of the patch means are formed by removing portions of the conductive layer on the one side of a second segment of the circuit board, and wherein the
10 first and second segments of the circuit board are then mounted in parallel spaced relationship, and shorting members are applied between the ground member and the

- 13 -

second patches proximate the one end of the ground member and the second patches.

12. A dual-band microstrip antenna as in claim 9, wherein the antenna is formed from printed circuit board having a conductive layer on one side, wherein the conducting surfaces of the ground member are formed by
5 removing portions of the conductive layer on the one side of a first segment of the circuit board, wherein the conducting surfaces of the patch means are formed by removing portions of the conductive layer on the one side
10 of a second segment of the circuit board, wherein the first and second segments of the circuit board are then mounted in parallel spaced relationship, and wherein shorting members are applied between the one end of the ground member and the one end of the first and second patches.

13. A dual-band microstrip antenna comprising at least two interconnected conductive radiating structures, at least one of the structures being apertured at locations where, if apertures were not present, induced currents would be relatively low compared to currents in other parts of the structure.

FIG. 1

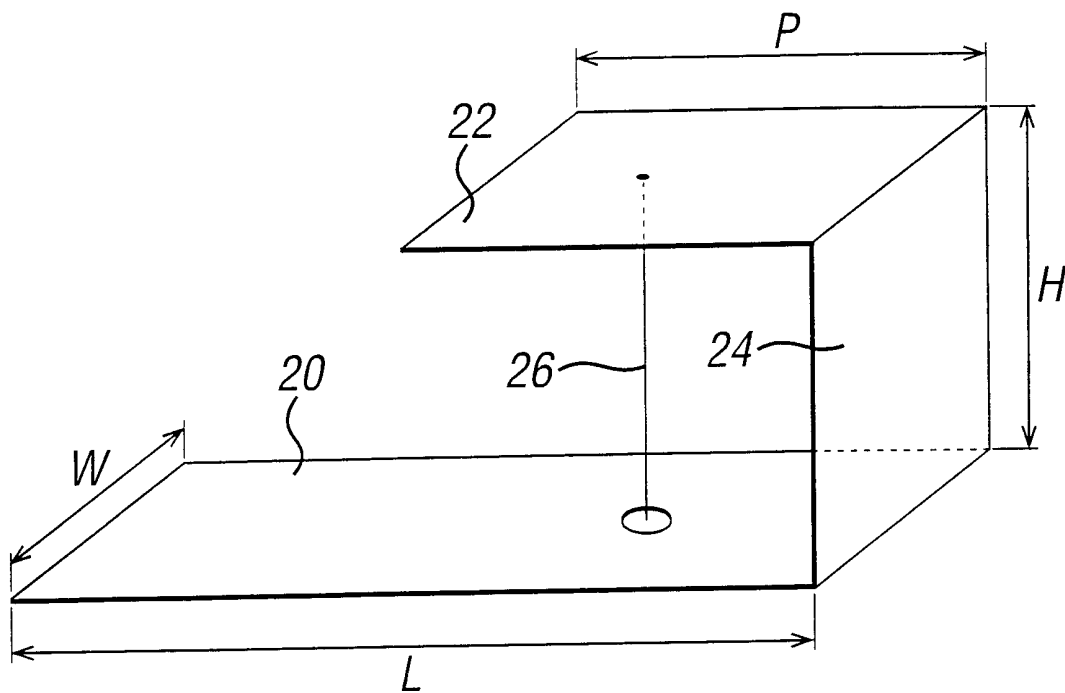
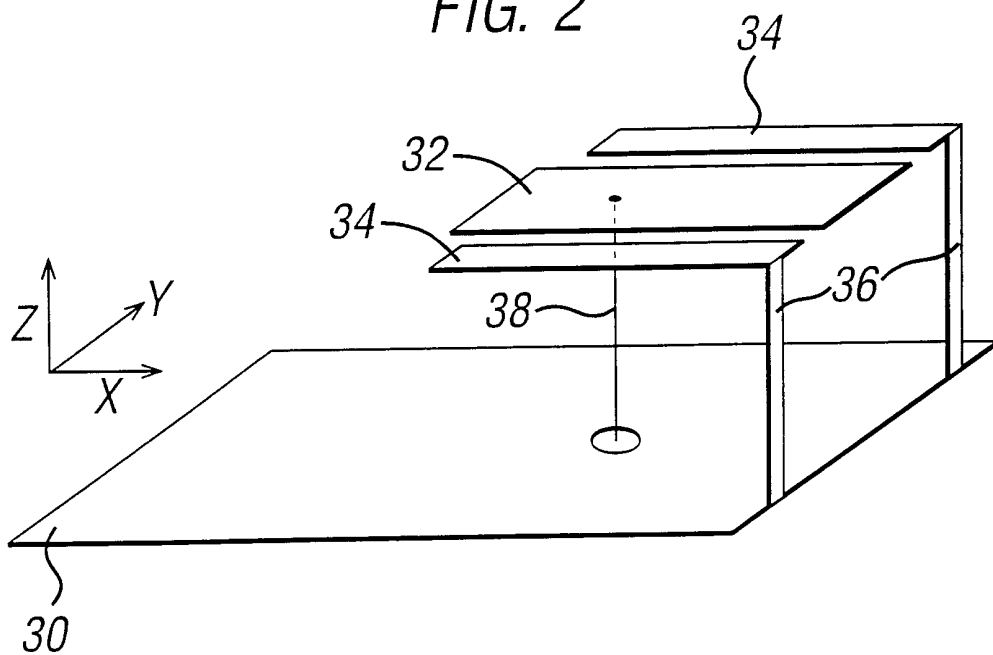
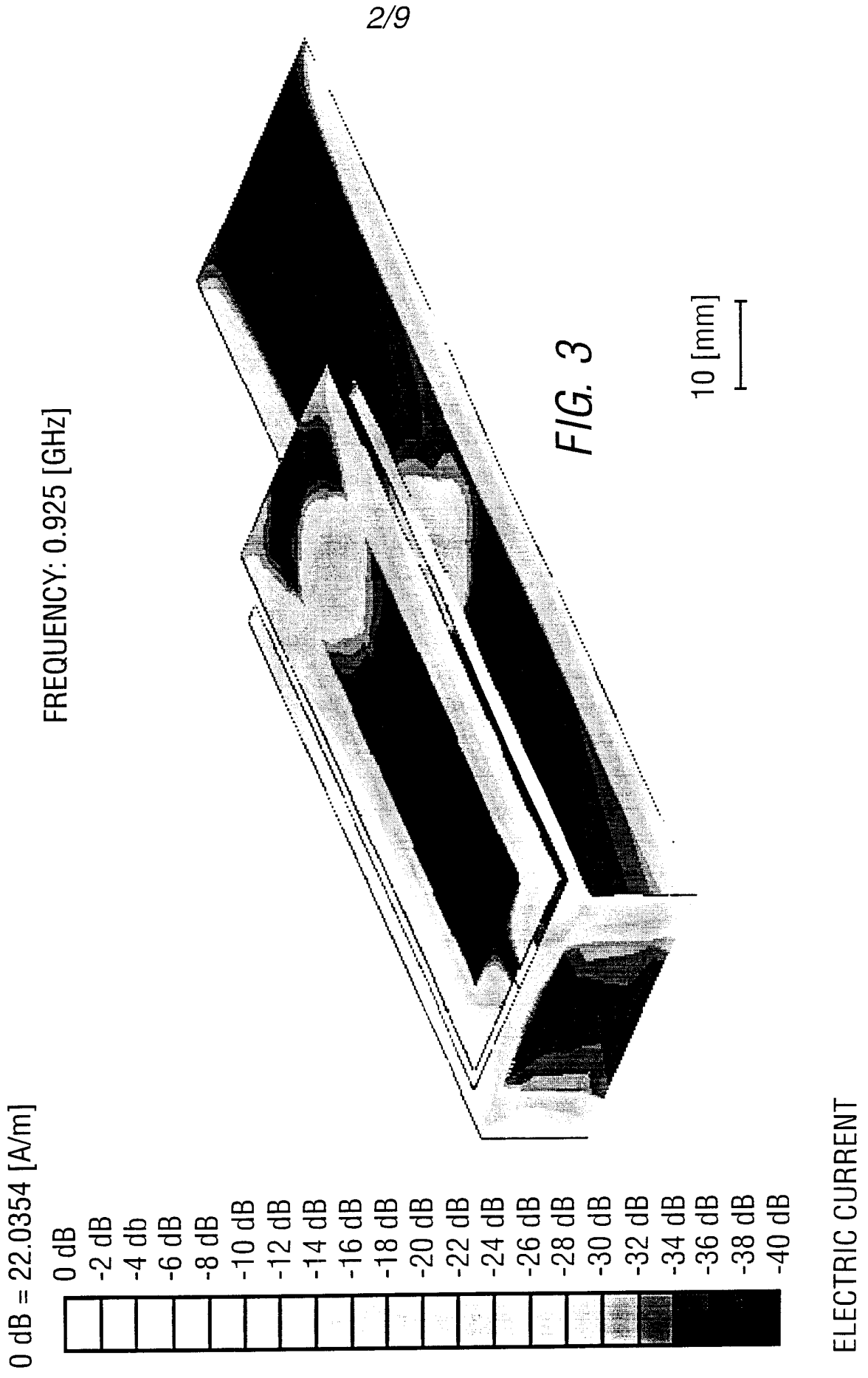

FIG. 2





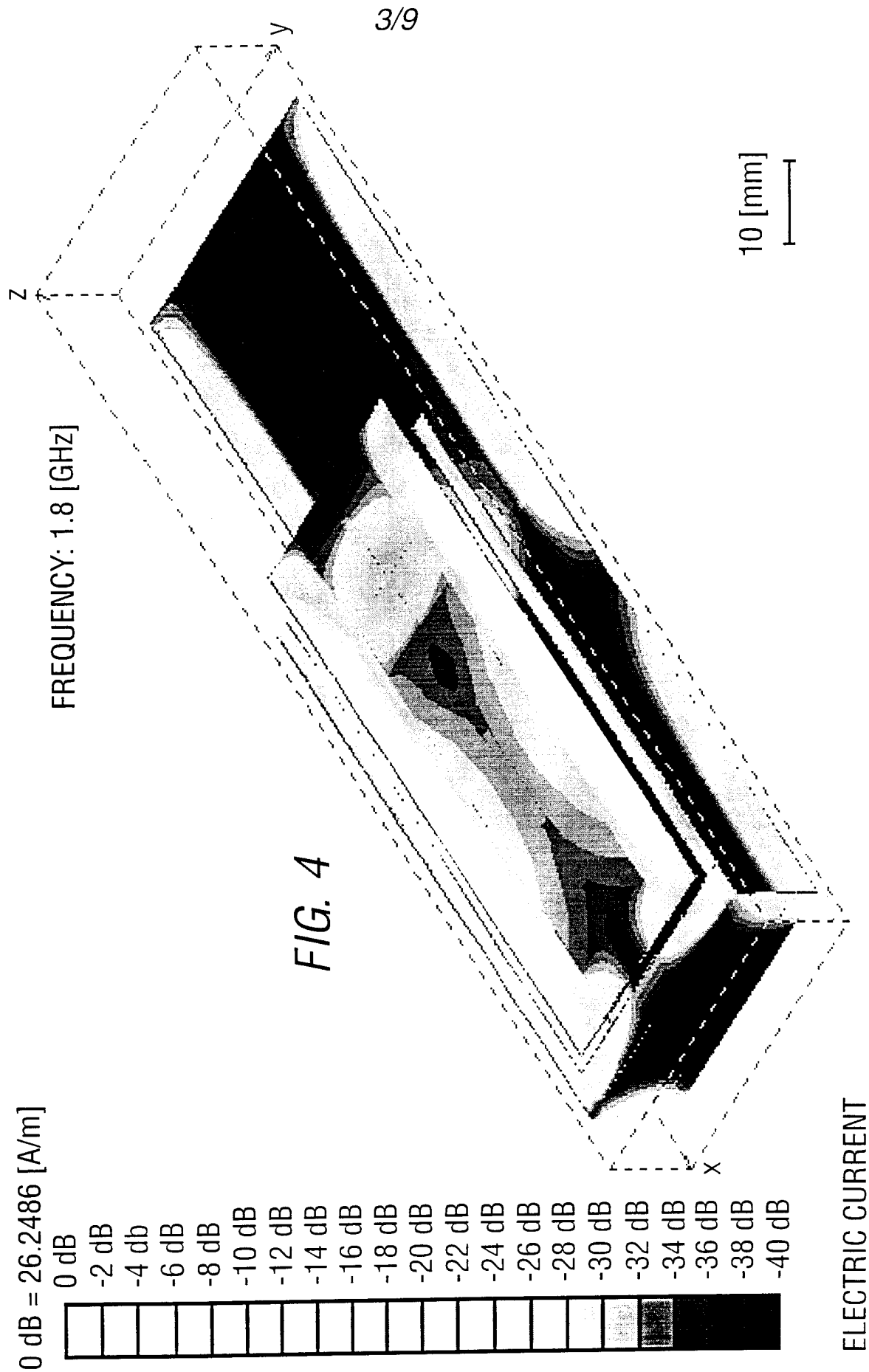

FIG. 5

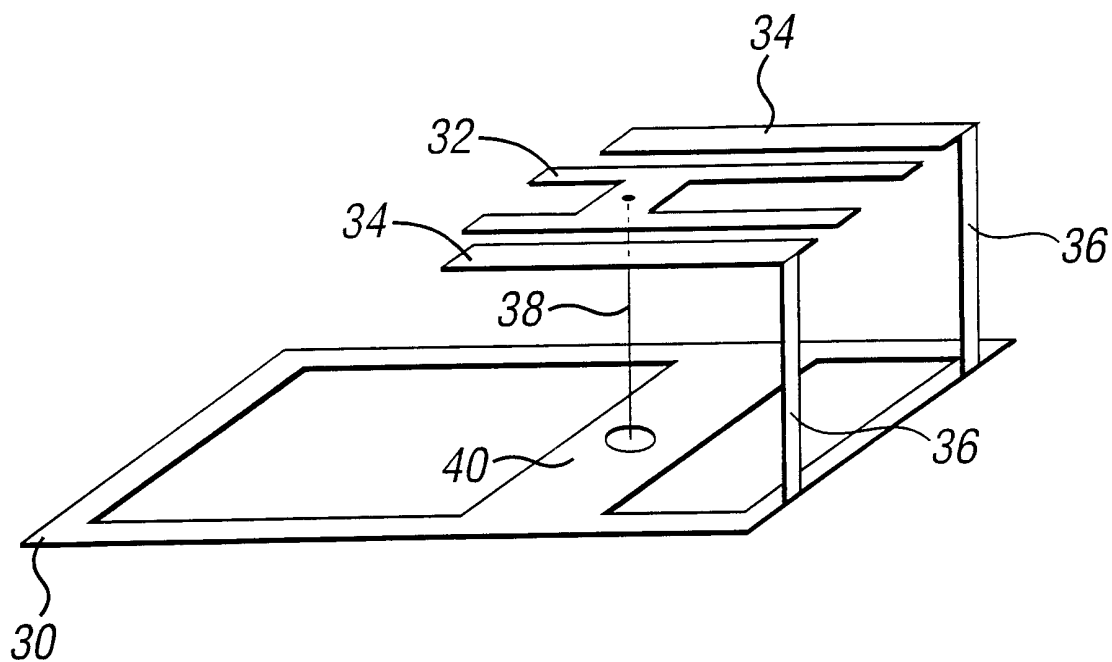
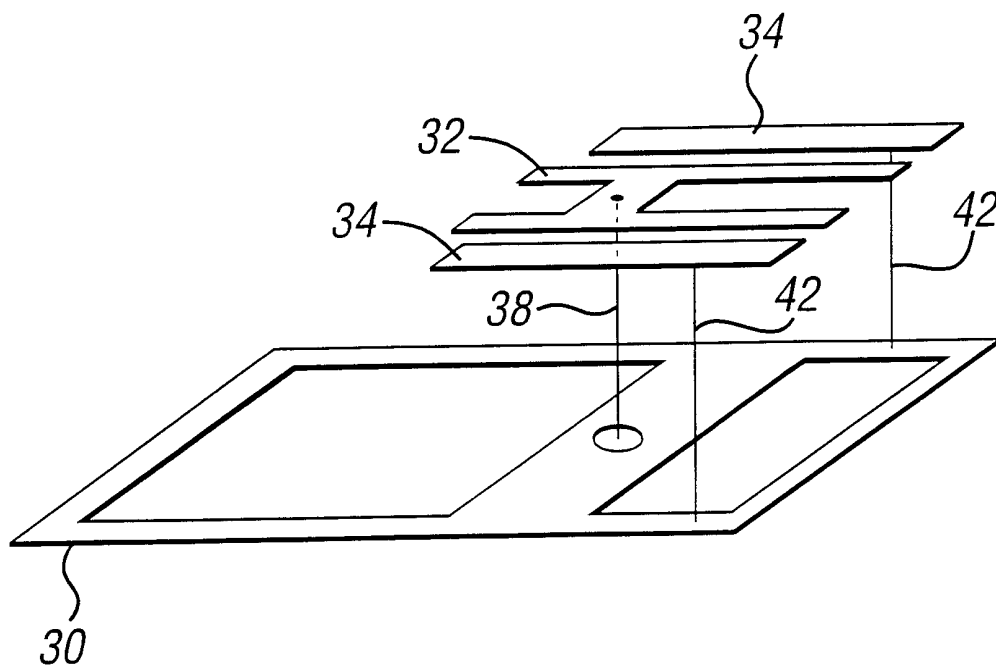

FIG. 6



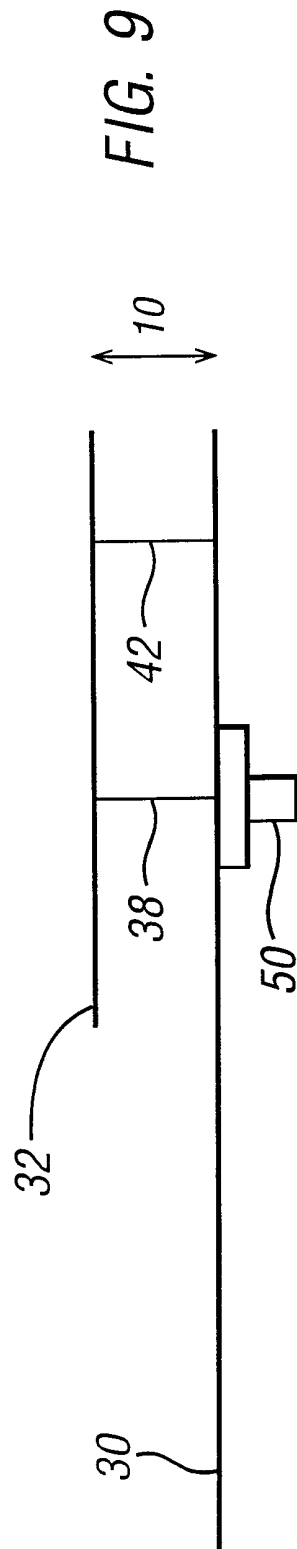
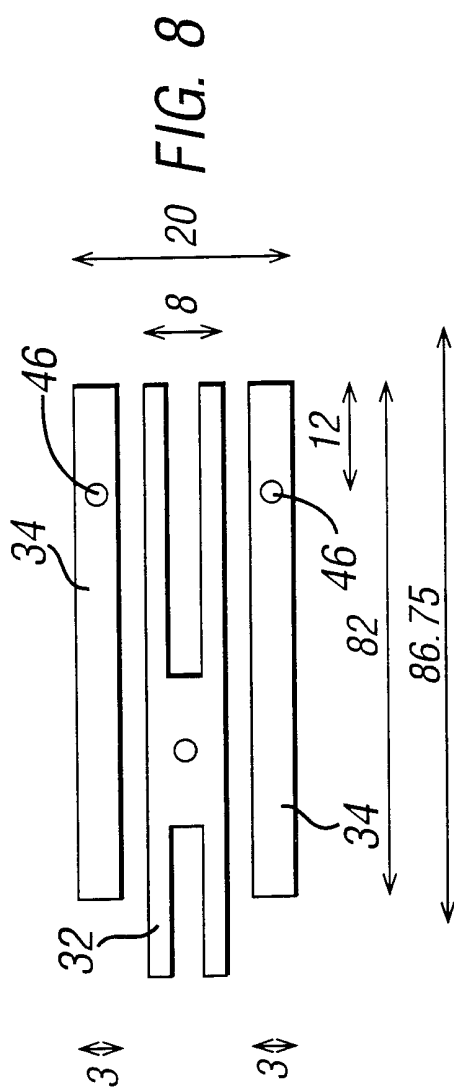
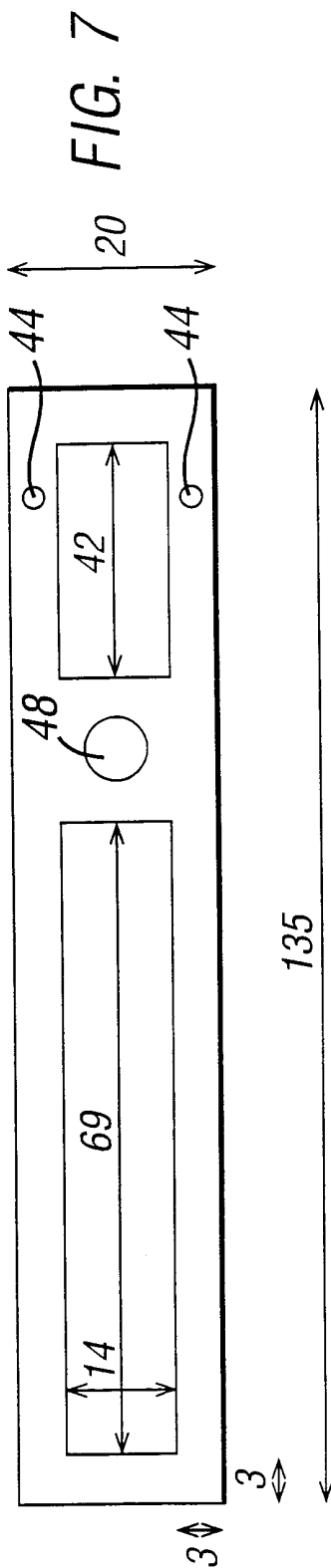

FIG. 10

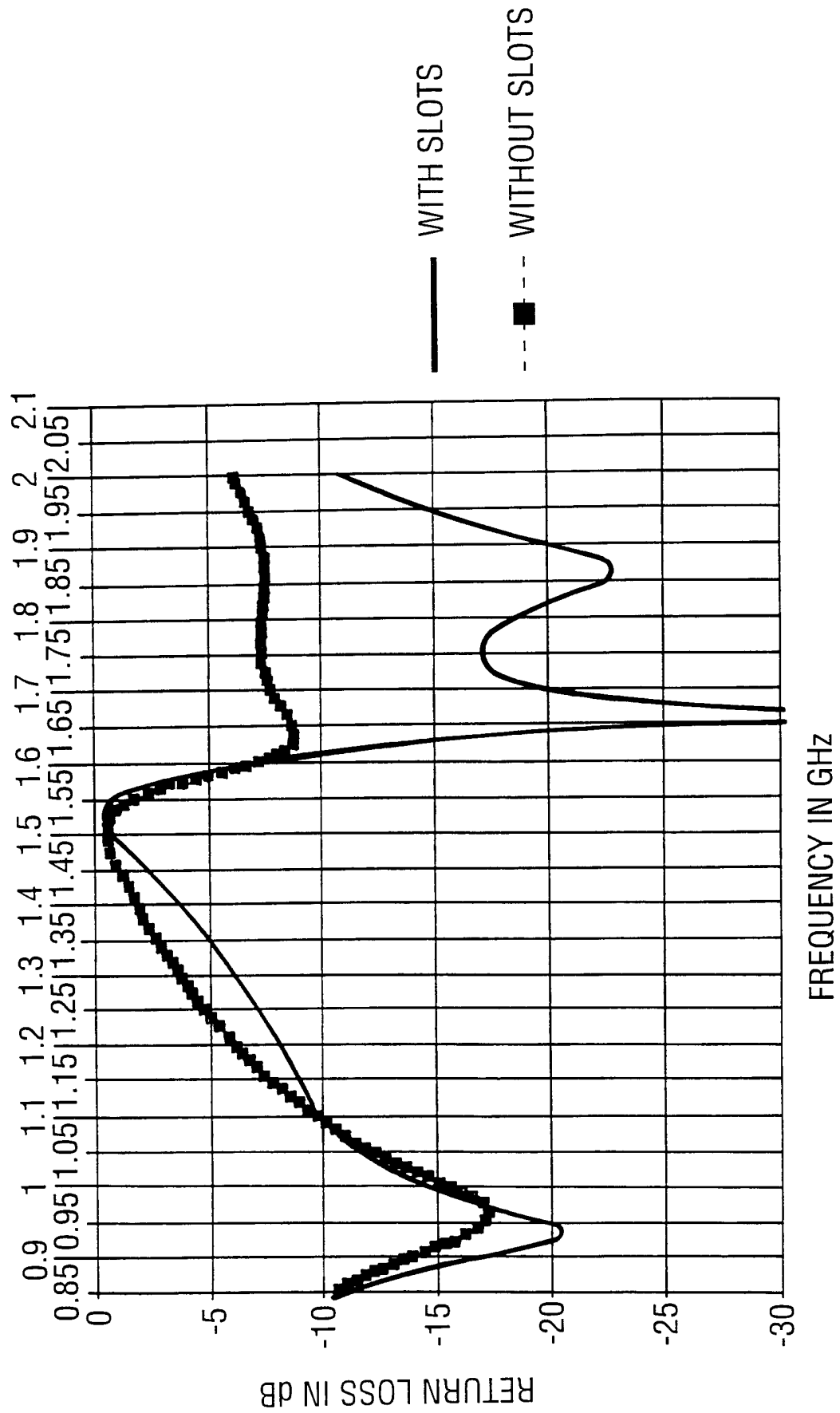
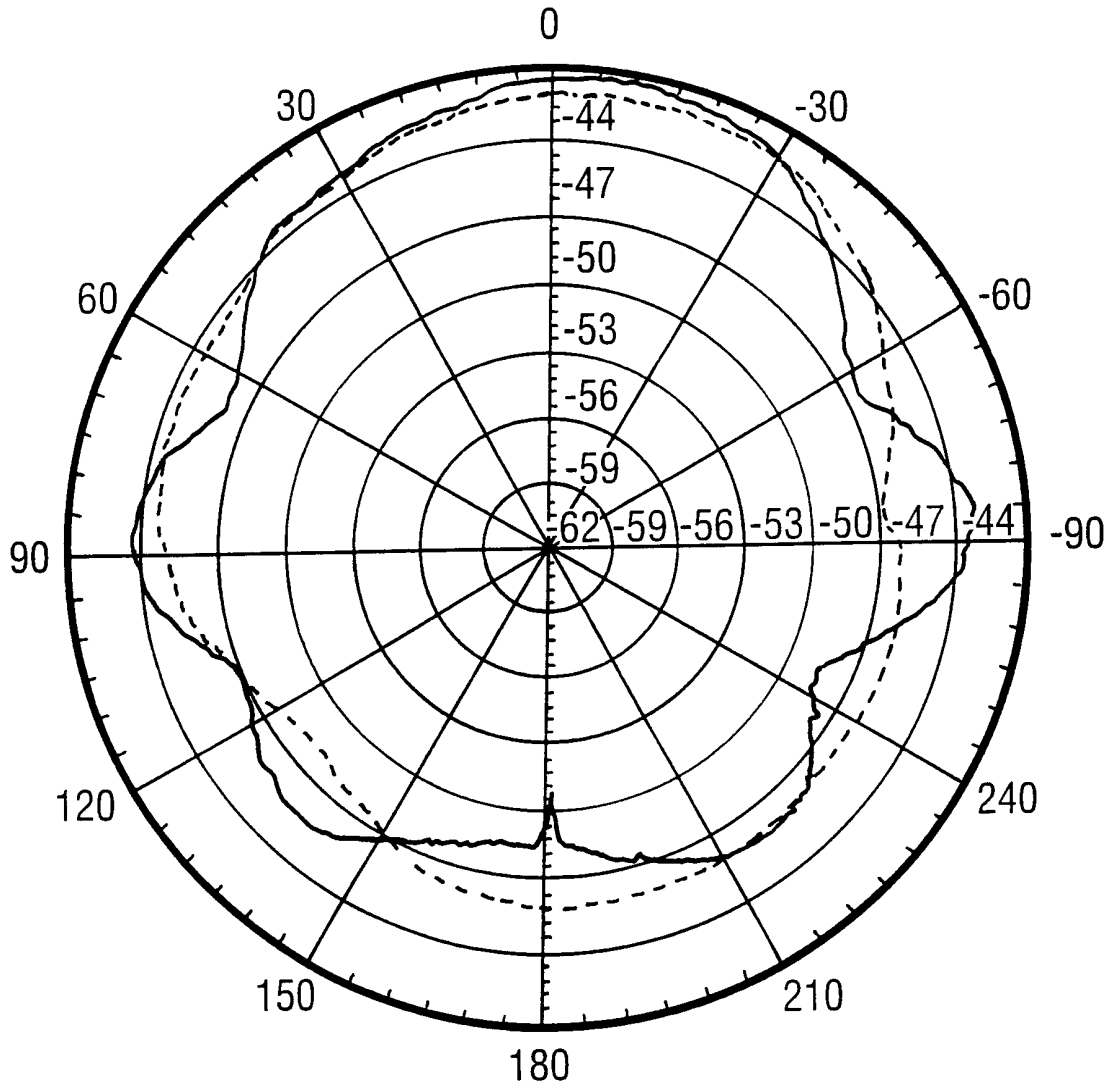

FIG. 11

PHI = 90 DEGREES



MEASURED RADIATION PATTERNS IN YZ PLANE

- F = 925 MHz : COPOLARIZATION
- F = 1.8 GHz : COPOLARIZATION

FIG. 12

PHI = 0 DEGREES

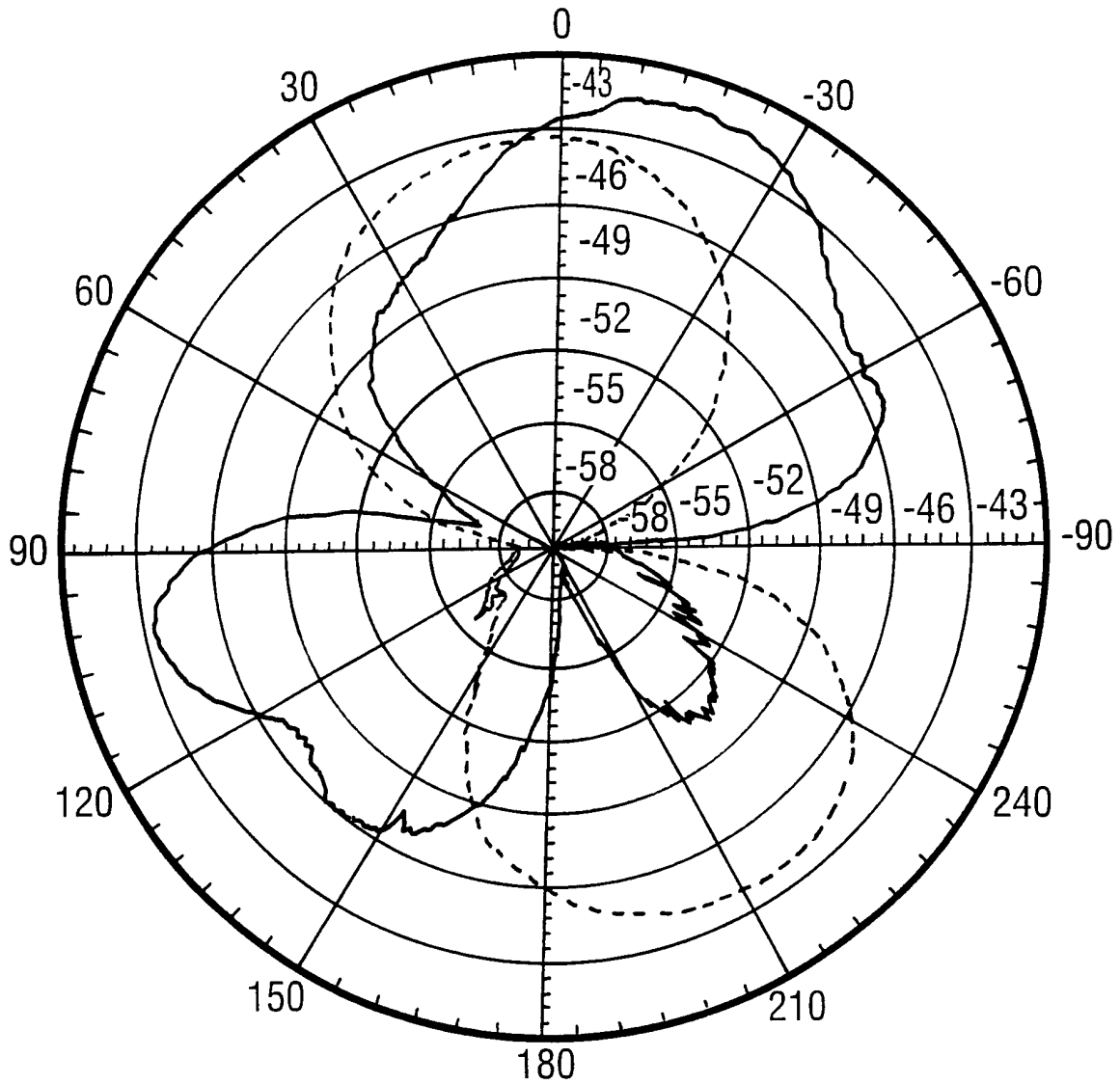

MEASURED RADIATION PATTERNS IN XZ PLANE

- 925 MHz COPOLARIZATION
- 1.8 GHz COPOLARIZATION

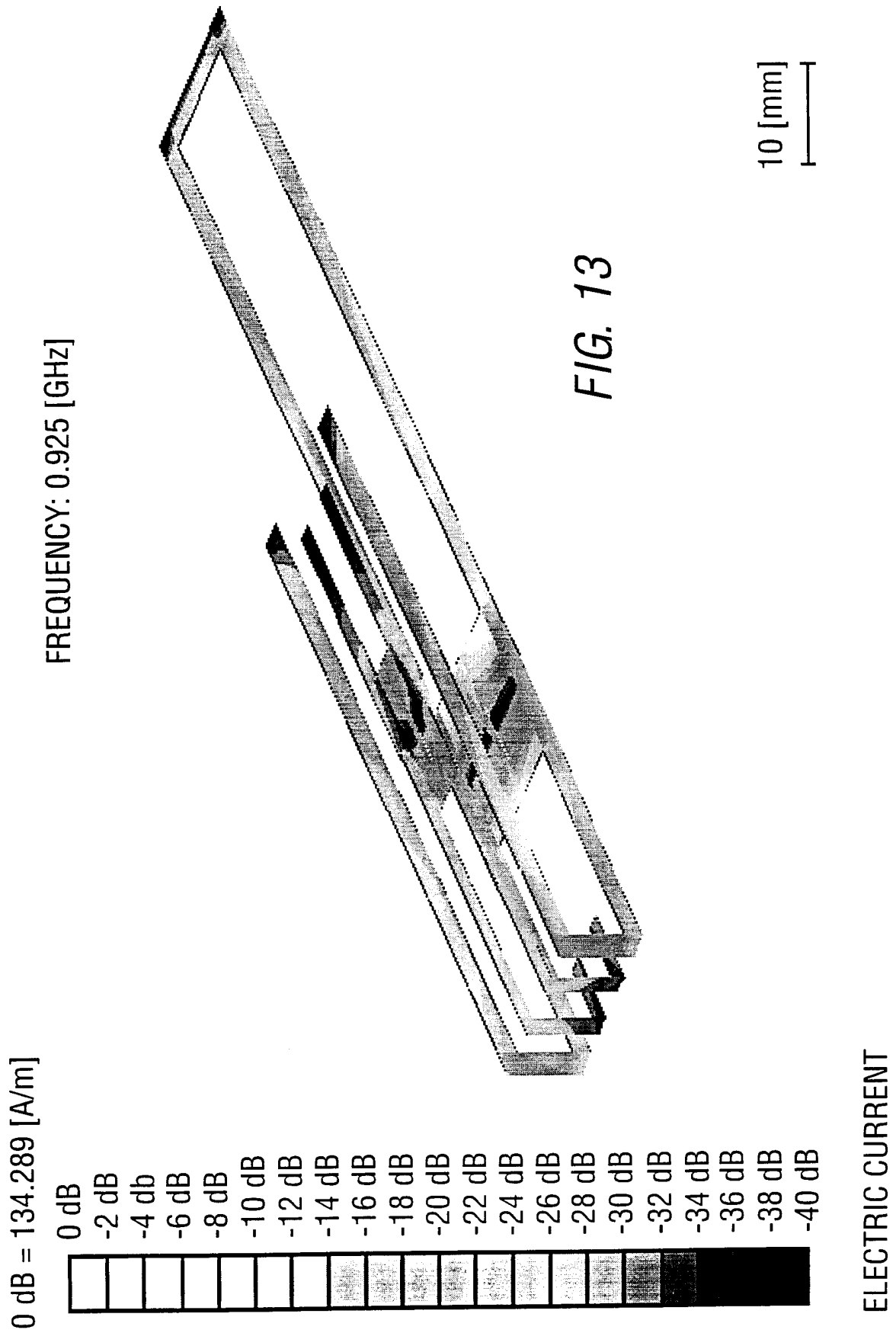

INTERNATIONAL SEARCH REPORT

Intern. Application No

PCT/GB 00/03746

A. CLASSIFICATION OF SUBJECT MATTER
 IPC 7 H01Q9/04 H01Q5/00

According to International Patent Classification (IPC) or to both national classification and IPC

B. FIELDS SEARCHED

Minimum documentation searched (classification system followed by classification symbols)

IPC 7 H01Q

Documentation searched other than minimum documentation to the extent that such documents are included in the fields searched

Electronic data base consulted during the international search (name of data base and, where practical, search terms used)

EPO-Internal, WPI Data, PAJ

C. DOCUMENTS CONSIDERED TO BE RELEVANT

Category °	Citation of document, with indication, where appropriate, of the relevant passages	Relevant to claim No.
X	US 5 365 246 A (BONEK ERNST ET AL) 15 November 1994 (1994-11-15) column 1, line 48 -column 3, line 5 column 5, line 7 - line 15; figure 5 ---	1-5, 13
X	WO 98 44588 A (QUALCOMM INC) 8 October 1998 (1998-10-08) figure 2 ---	1, 2, 13
A	WO 99 28990 A (AMANO TAKASHI ;IWASAKI HISAO (JP); CHIBA NORIMICHI (JP); TOKYO SHI) 10 June 1999 (1999-06-10) abstract --- -/--	1-13

Further documents are listed in the continuation of box C.

Patent family members are listed in annex.

° Special categories of cited documents :

- *A* document defining the general state of the art which is not considered to be of particular relevance
- *E* earlier document but published on or after the international filing date
- *L* document which may throw doubts on priority claim(s) or which is cited to establish the publication date of another citation or other special reason (as specified)
- *O* document referring to an oral disclosure, use, exhibition or other means
- *P* document published prior to the international filing date but later than the priority date claimed

- *T* later document published after the international filing date or priority date and not in conflict with the application but cited to understand the principle or theory underlying the invention
- *X* document of particular relevance: the claimed invention cannot be considered novel or cannot be considered to involve an inventive step when the document is taken alone
- *Y* document of particular relevance: the claimed invention cannot be considered to involve an inventive step when the document is combined with one or more other such documents, such combination being obvious to a person skilled in the art.
- *Z* document member of the same patent family

Date of the actual completion of the international search

11 December 2000

Date of mailing of the international search report

18/12/2000

Name and mailing address of the ISA

European Patent Office, P.B. 5818 Patentlaan 2
 NL - 2280 HV Rijswijk
 Tel. (+31-70) 340-2040. Tx. 31 651 epo nl,
 Fax: (+31-70) 340-3016

Authorized officer

Wattiaux, V

INTERNATIONAL SEARCH REPORT

International Application No

PCT/GB 00/03746

C.(Continuation) DOCUMENTS CONSIDERED TO BE RELEVANT

Category °	Citation of document, with indication, where appropriate, of the relevant passages	Relevant to claim No.
A	<p>CHO Y K ET AL: "IMPROVED ANALYSIS METHOD FOR BROADBAND RECTANGULAR MICROSTRIP ANTENNA GEOMETRY USING E-PLANE GAP COUPLING" ELECTRONICS LETTERS, GB, IEE STEVENAGE, vol. 29, no. 22, 28 October 1993 (1993-10-28), pages 1907-1909, XP000420968 ISSN: 0013-5194 figure 1</p> <p style="text-align: center;">---</p>	1-13
A	<p>EP 0 777 295 A (NIPPON TELEGRAPH & TELEPHONE) 4 June 1997 (1997-06-04) column 1, line 11 - line 26; figure 2</p> <p style="text-align: center;">-----</p>	1-13

INTERNATIONAL SEARCH REPORT

Information on patent family members

Interr. Patent Application No

PCT/GB 00/03746

Patent document cited in search report	A	Publication date	Patent family member(s)	Publication date
US 5365246	A	15-11-1994	AT 393054 B AT 181589 A AT 112421 T DE 59007355 D WO 9102386 A EP 0484454 A JP 5500889 T	12-08-1991 15-12-1990 15-10-1994 03-11-1994 21-02-1991 13-05-1992 18-02-1993
WO 9844588	A	08-10-1998	AU 6584698 A	22-10-1998
WO 9928990	A	10-06-1999	NONE	
EP 0777295	A	04-06-1997	CA 2190792 A CN 1159664 A JP 9214244 A US 5917450 A	30-05-1997 17-09-1997 15-08-1997 29-06-1999