



US 20020122006A1

(19) **United States**

(12) **Patent Application Publication**
Crawford

(10) **Pub. No.: US 2002/0122006 A1**

(43) **Pub. Date: Sep. 5, 2002**

(54) **CONFORMAL BOX ANTENNA**

(52) **U.S. Cl. 343/702; 343/700 MS; 343/844**

(75) **Inventor: James A. Crawford, San Diego, CA (US)**

Correspondence Address:
FITCH EVEN TABIN AND FLANNERY
120 SOUTH LA SALLE STREET
SUITE 1600
CHICAGO, IL 60603-3406 (US)

(57) **ABSTRACT**

An antenna assembly that can conform to two or more noncoplanar walls of a housing associated with numerous different devices that communicate in a WLAN. At least two antenna elements are included with a first antenna element attached to a portion of a first wall and a second antenna element attached to a portion of a second wall. Active circuitry is attached to the backside of the antenna assembly and coupled to the antenna elements. The antenna assembly can be included on a base that can be easily added-on to a product. Spatial and/or polarization diversity can be achieved in a small form-factor at high frequencies, including the 5 to 6 GHz frequency band.

(73) **Assignee: Magis Networks, Inc.**

(21) **Appl. No.: 09/799,411**

(22) **Filed: Mar. 5, 2001**

Publication Classification

(51) **Int. Cl.⁷ H01Q 1/24; H01Q 1/38; H01Q 21/00**

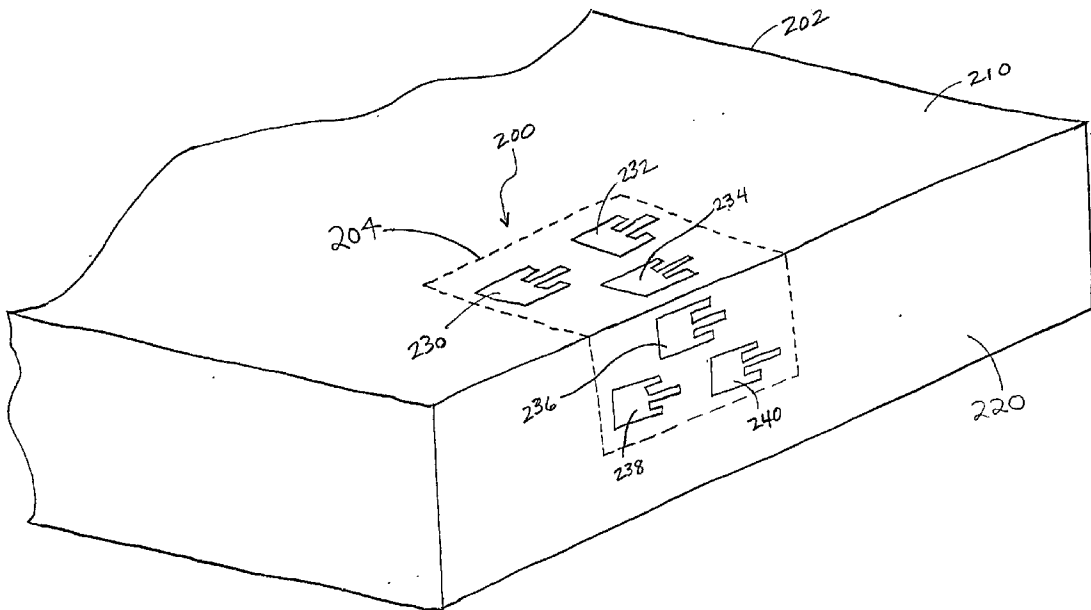

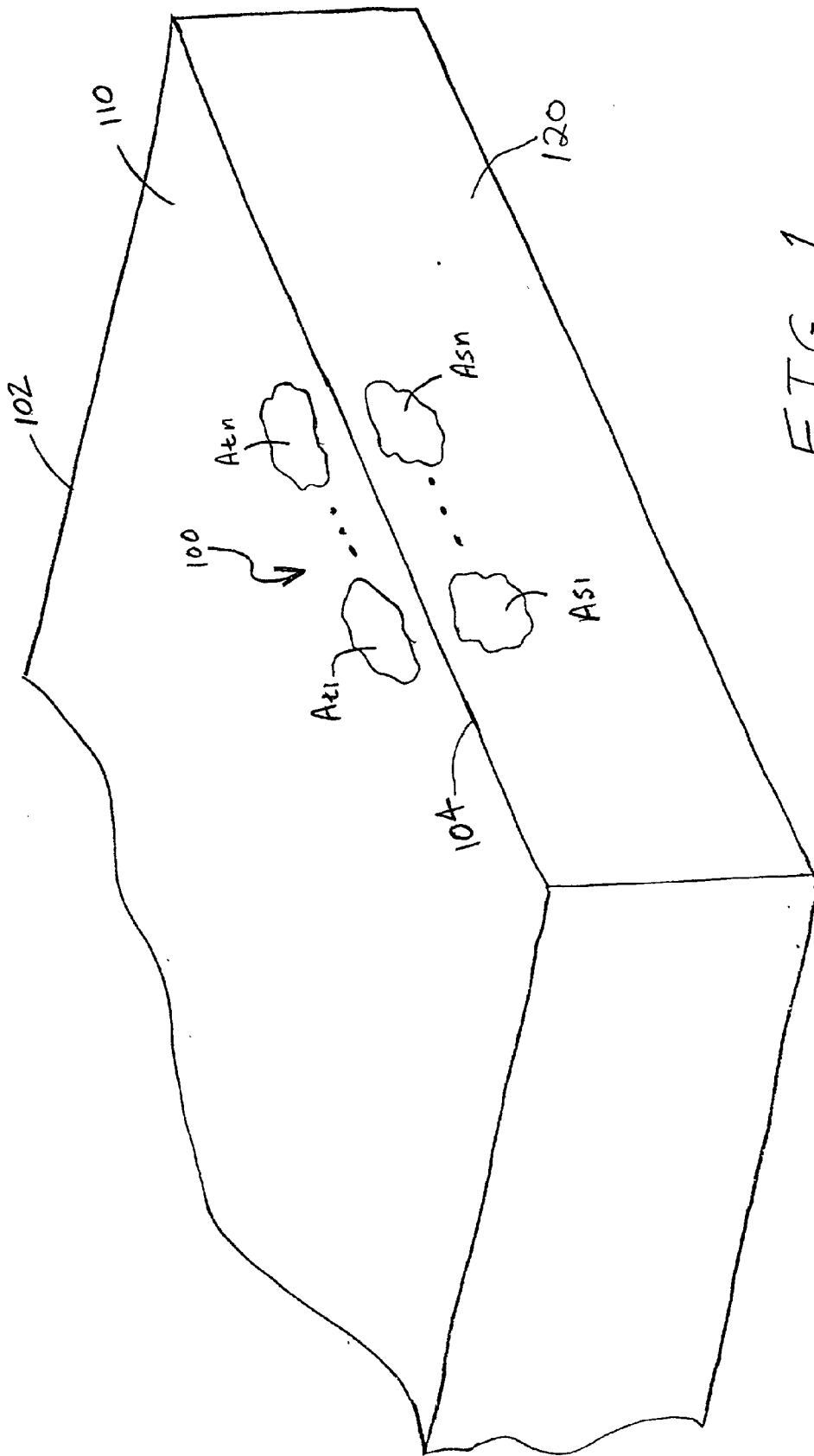

FIG. 1

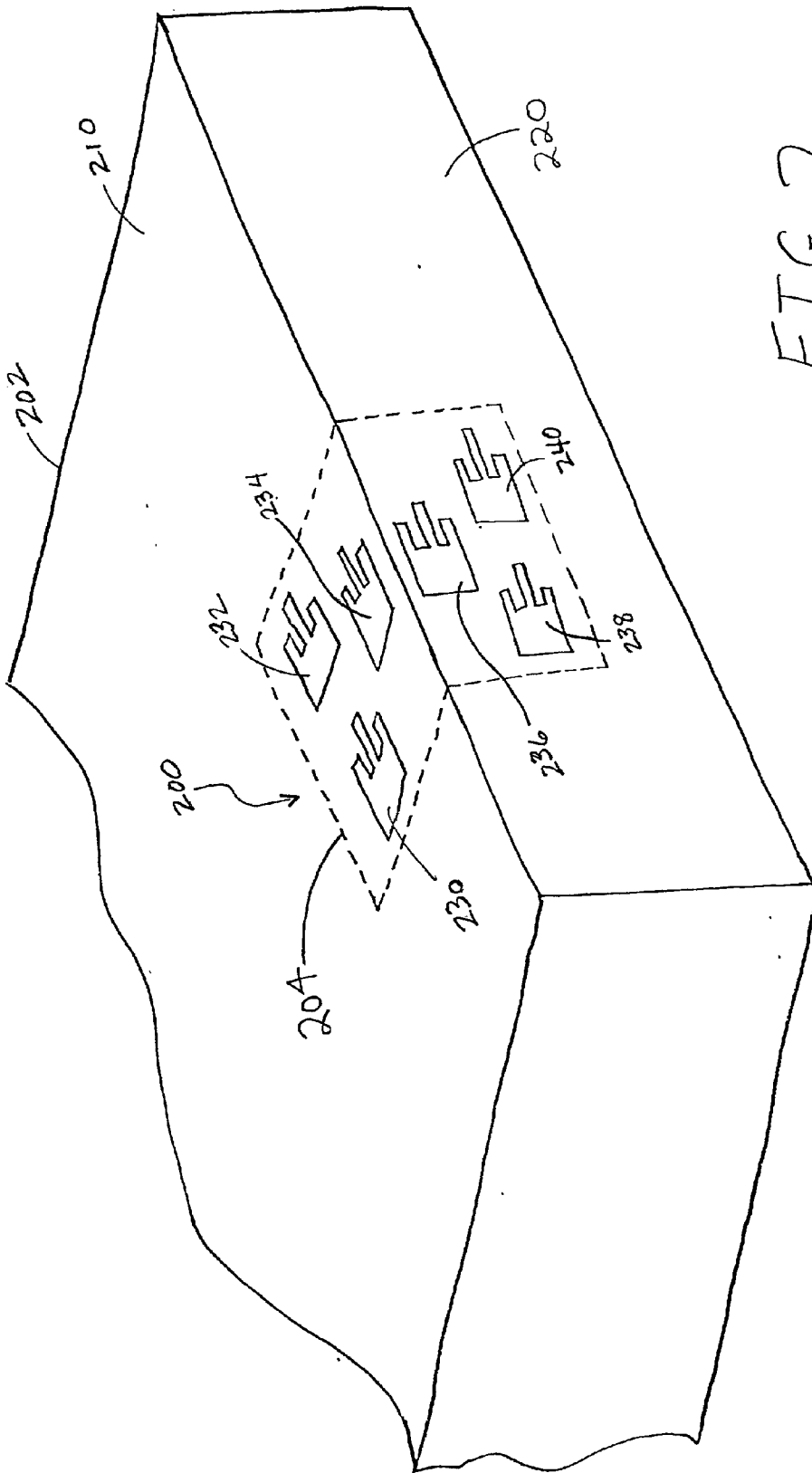

FIG. 2

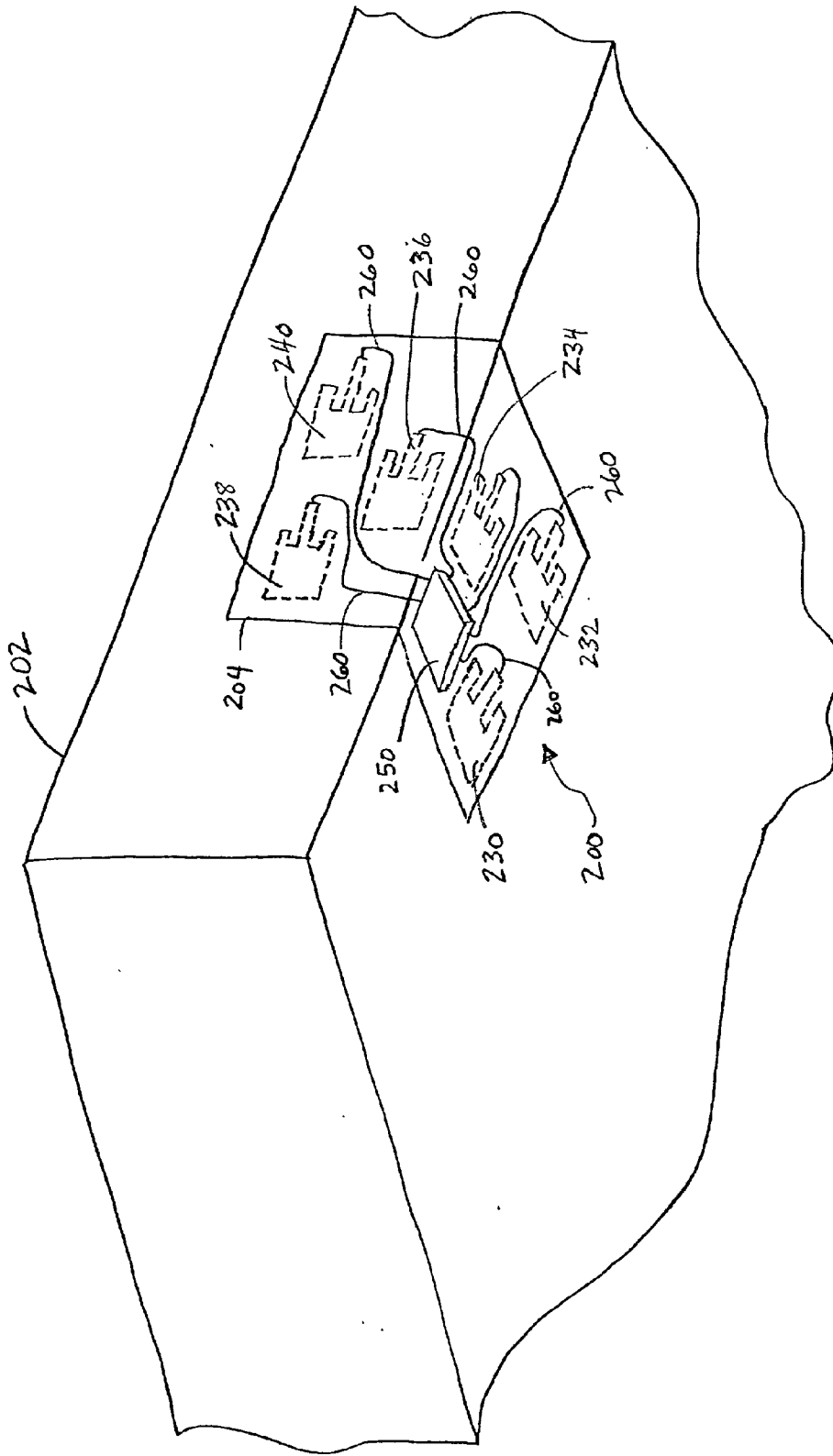

FIG. 3

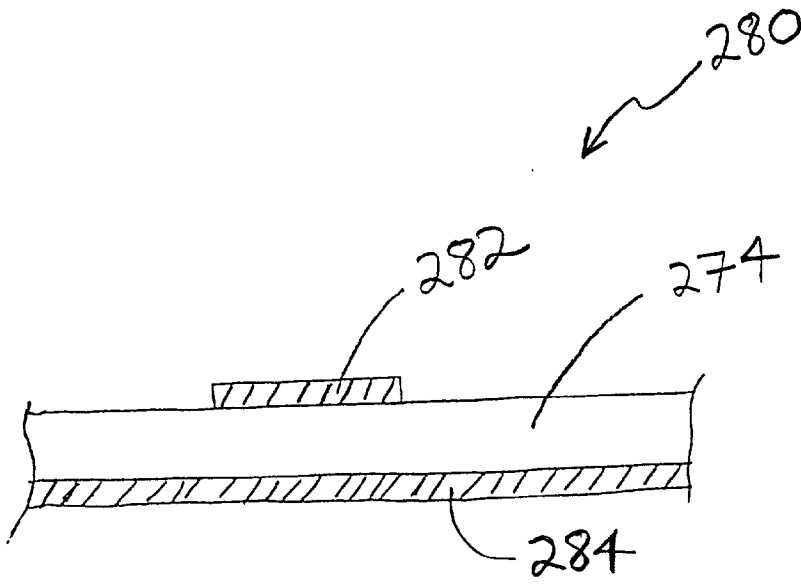

FIG. 4B

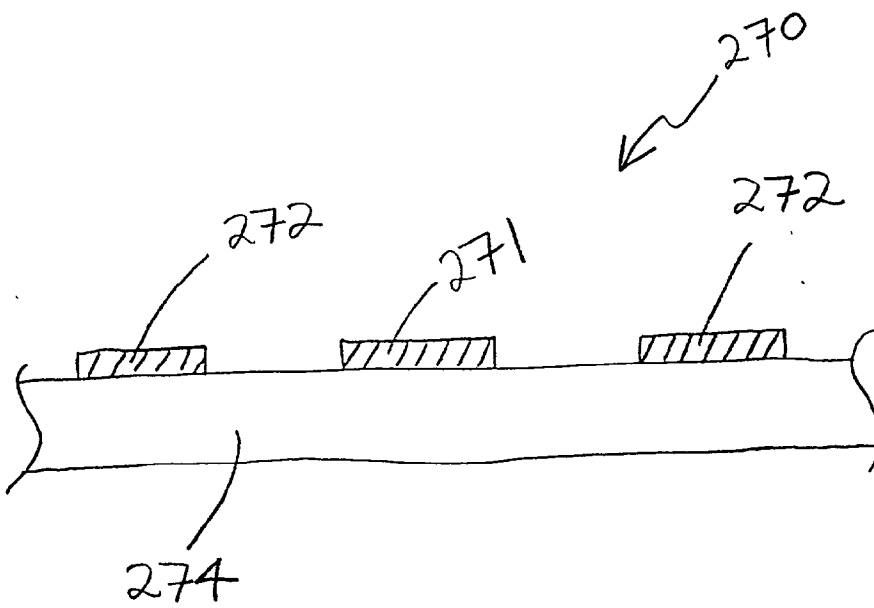
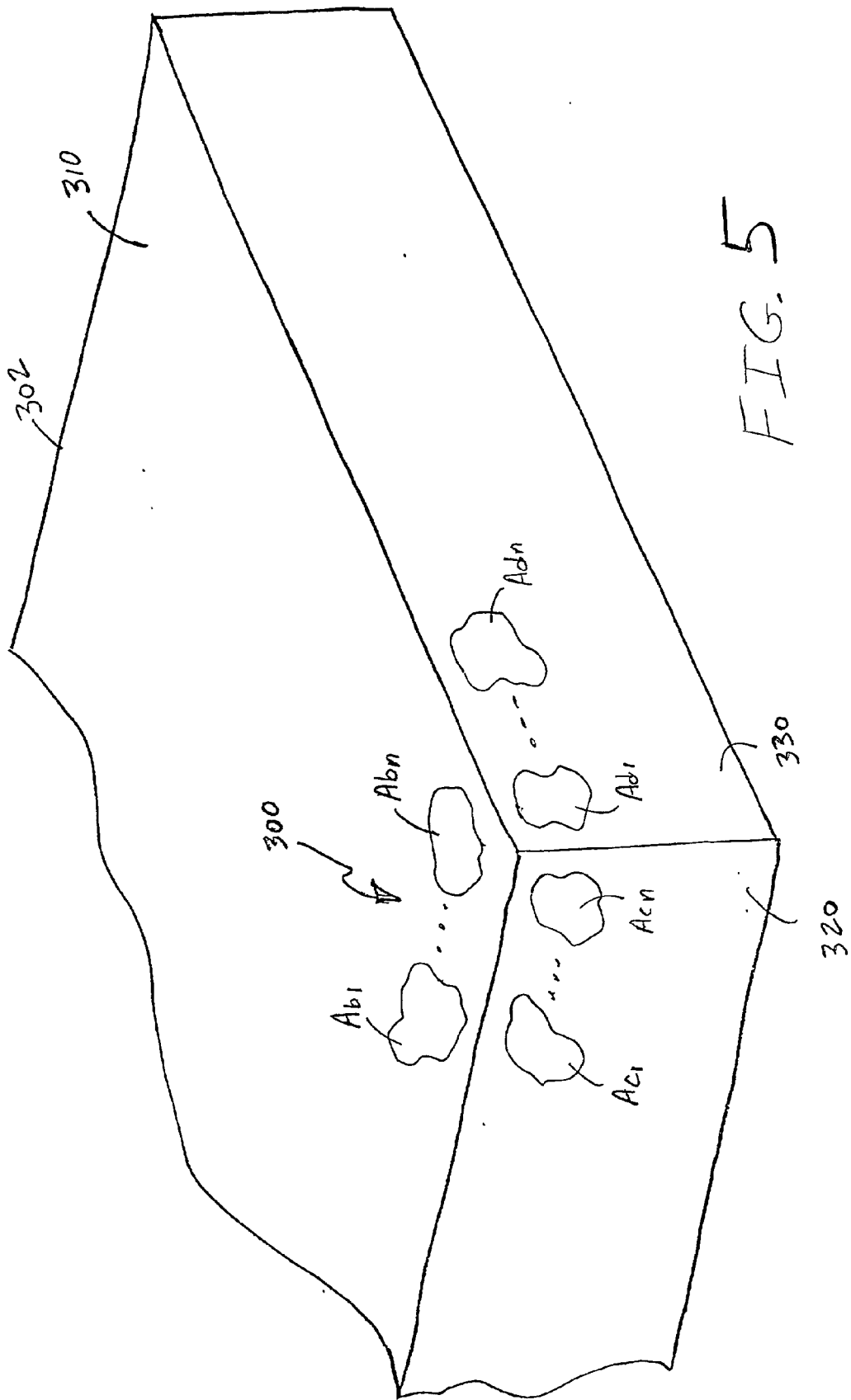
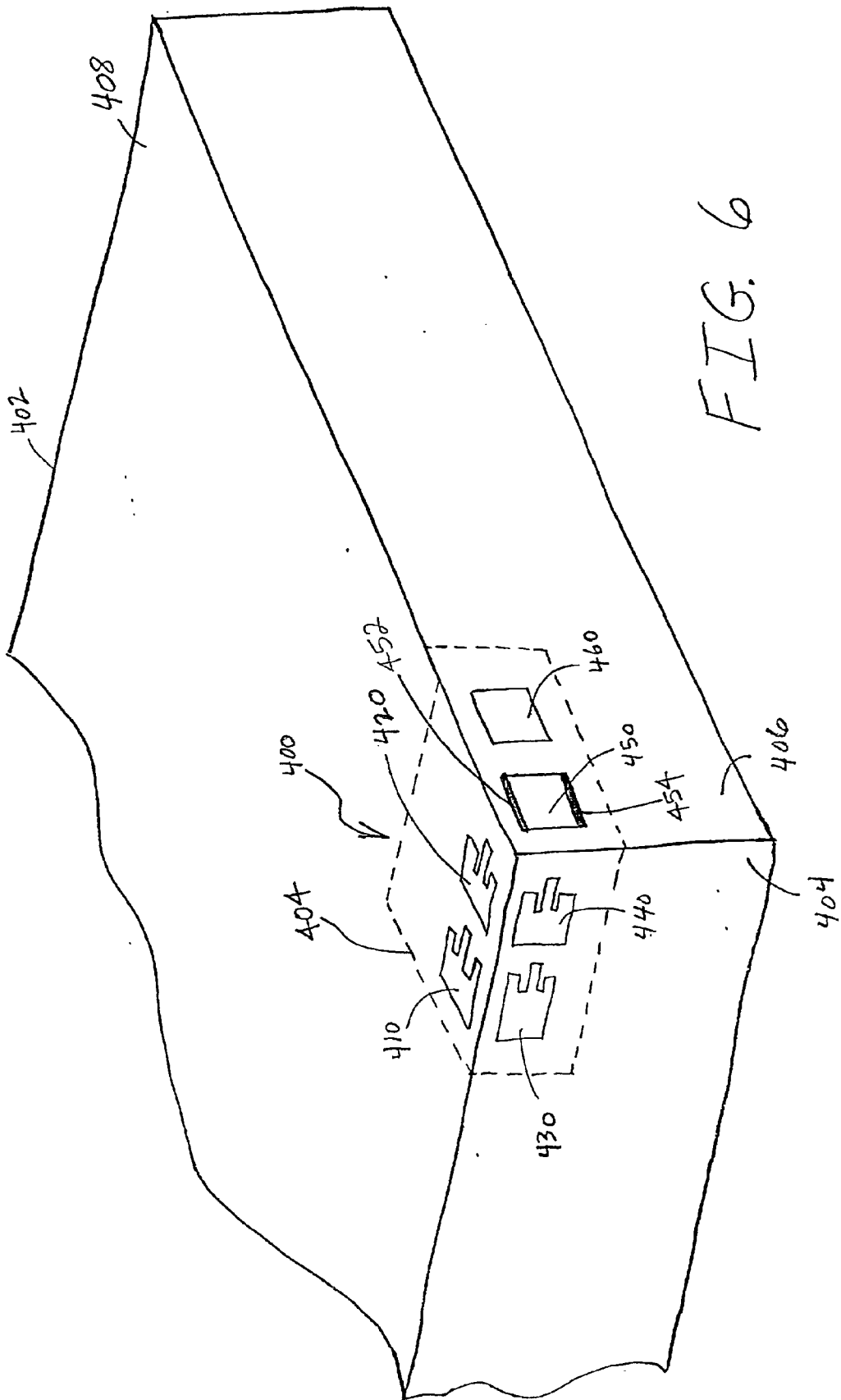

FIG. 4A





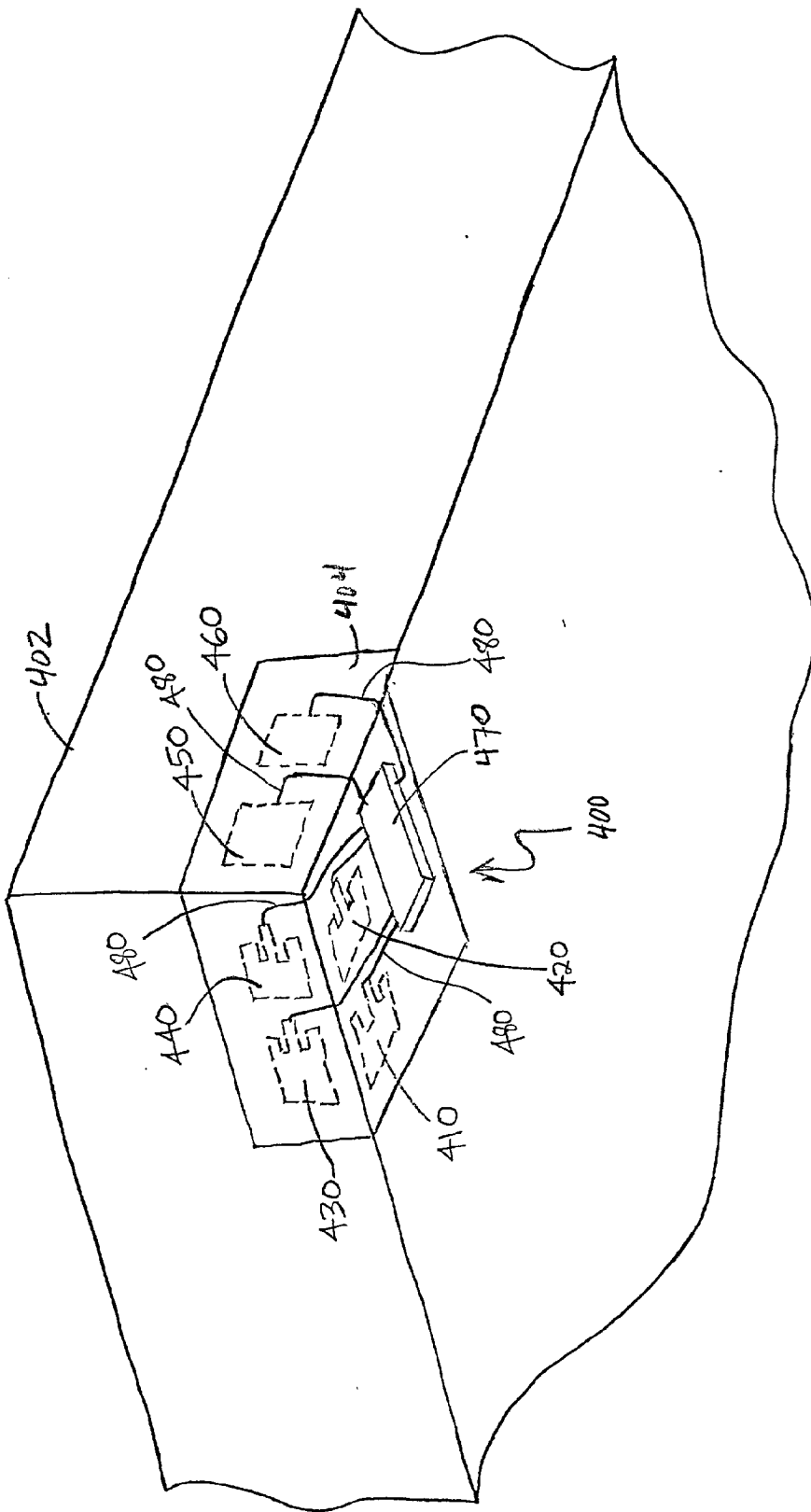

FIG. 7

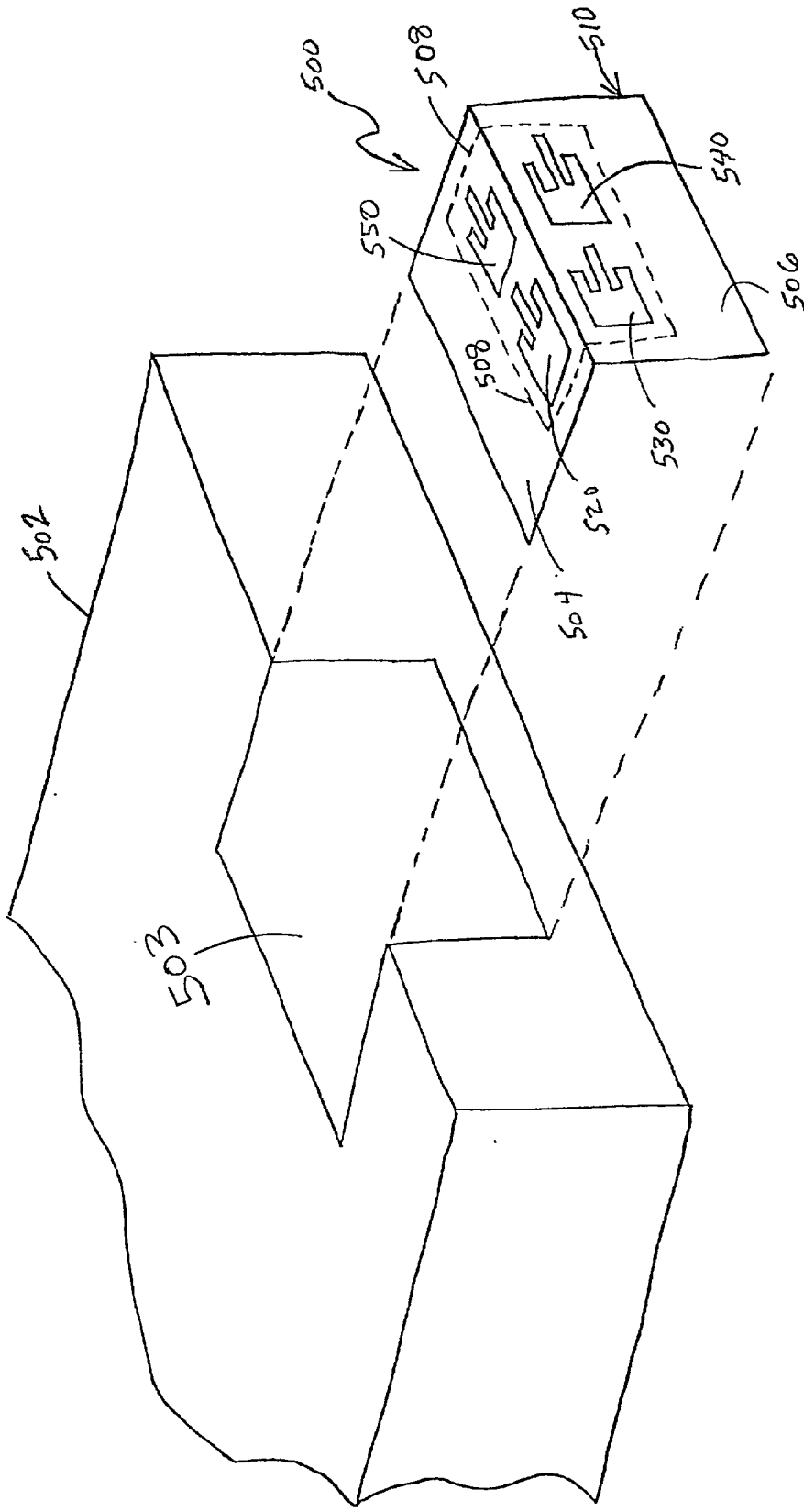

FIG. 8

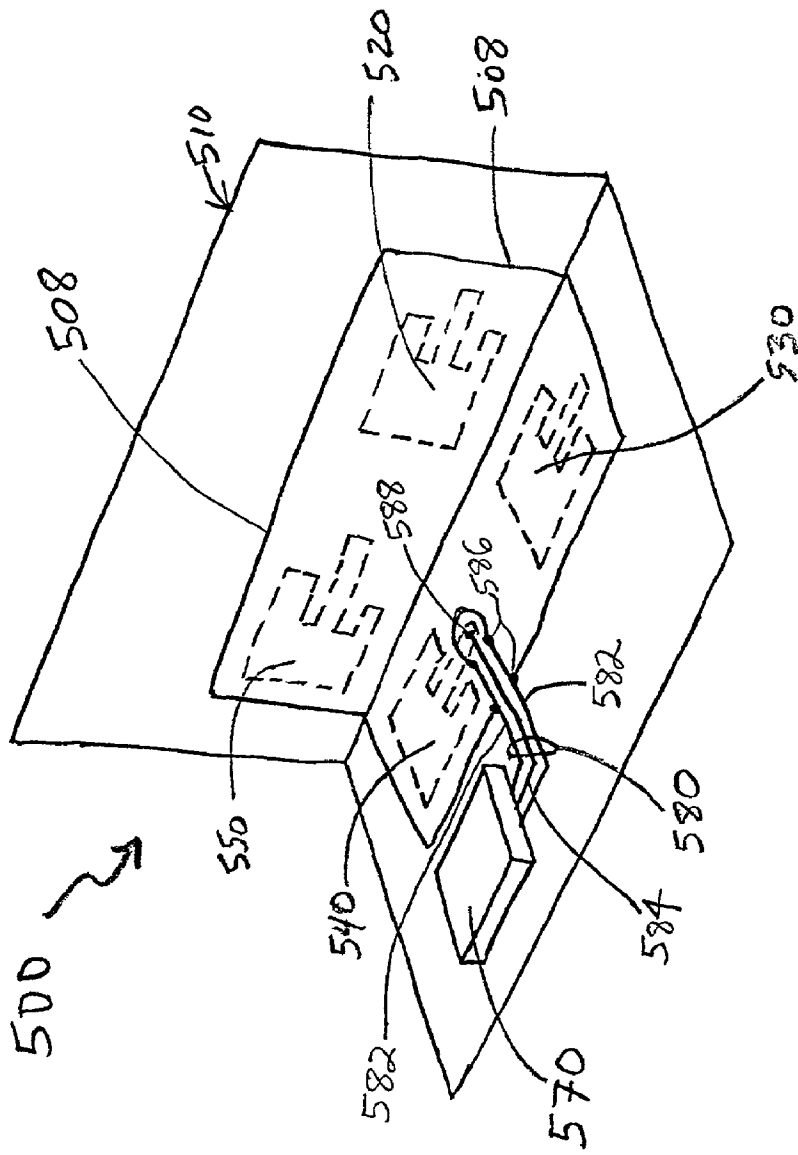

FIG. 9

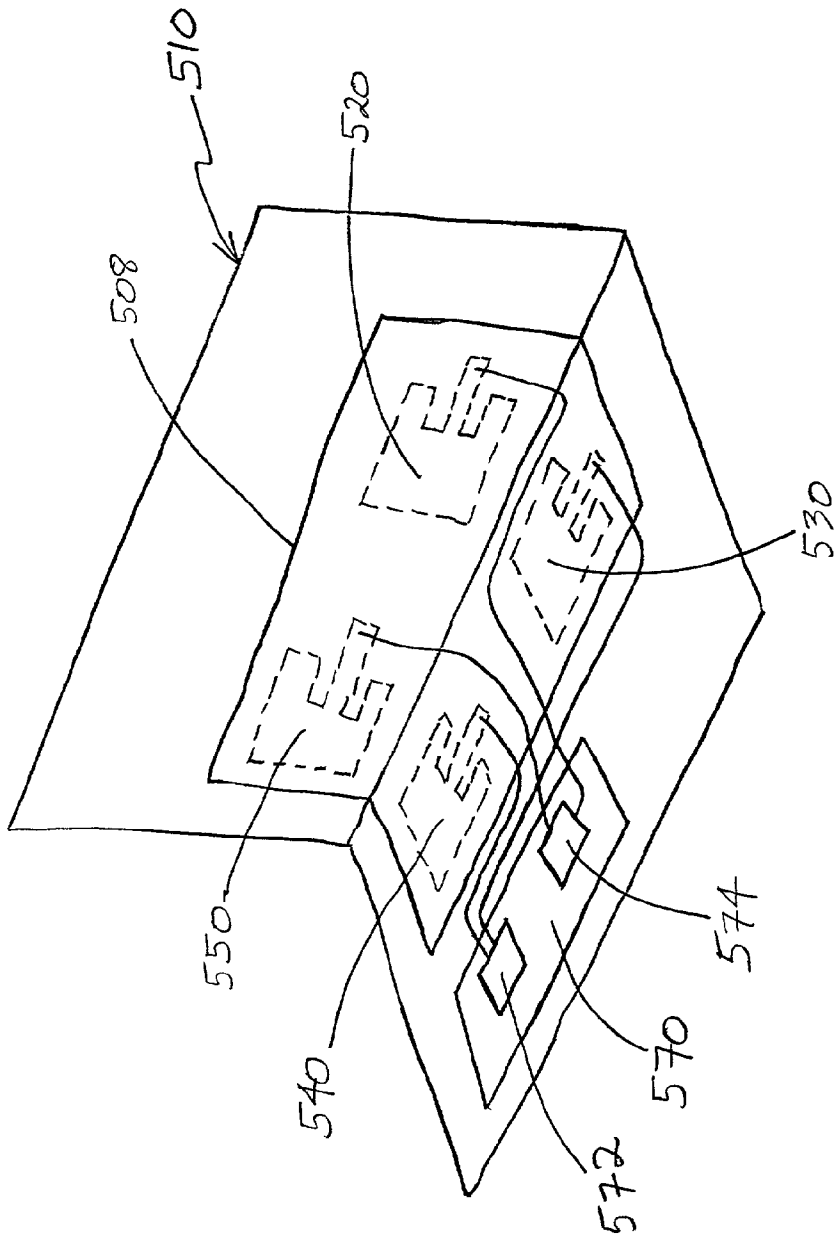

FIG. 10

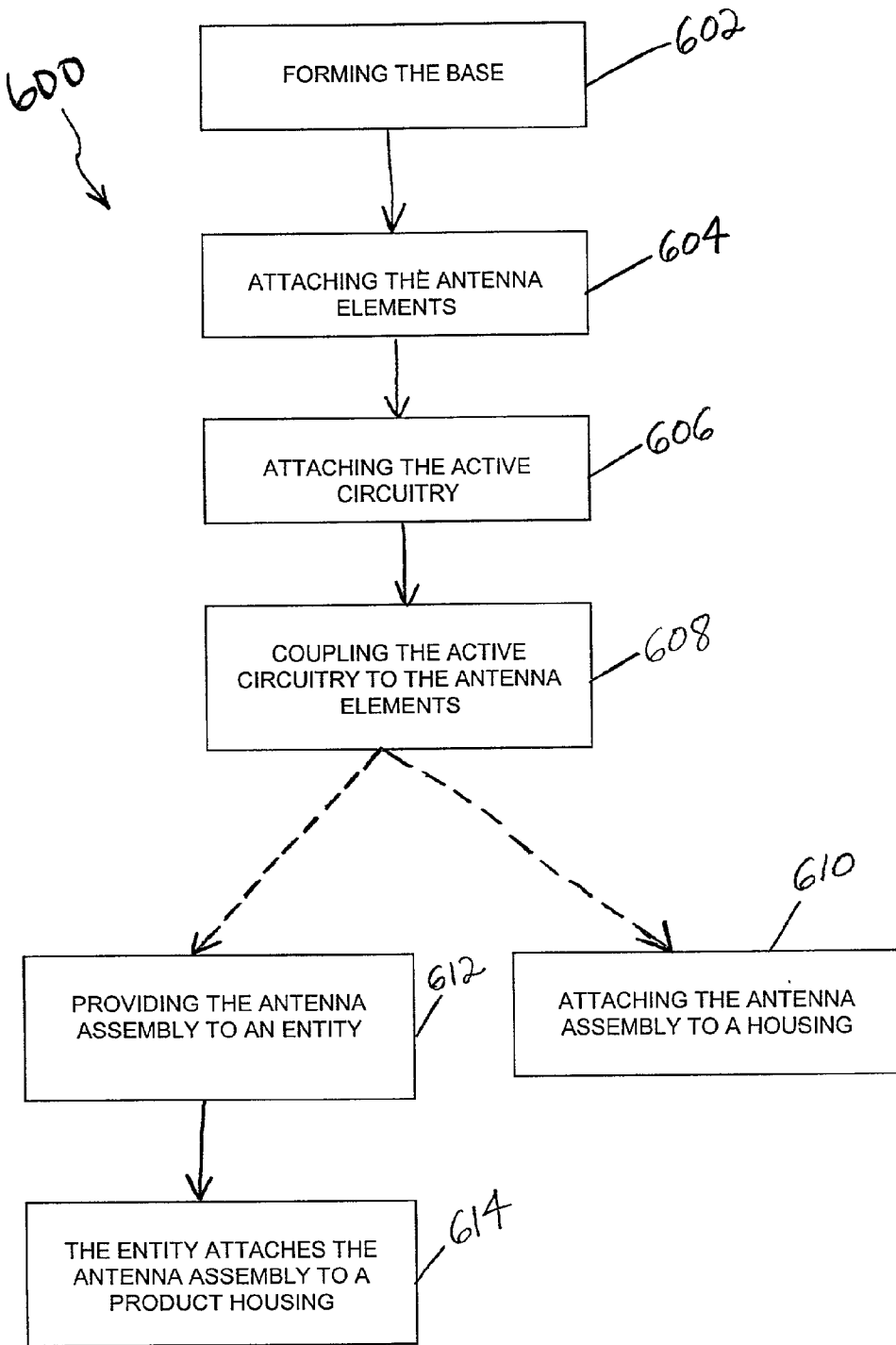

FIG. 11

CONFORMAL BOX ANTENNA

BACKGROUND OF THE INVENTION

[0001] 1. Field of the Invention

[0002] The present invention relates generally to antennas, and more specifically to small antenna structures possessing diversity characteristics.

[0003] 2. Discussion of the Related Art

[0004] A multipath environment is created when radio frequency (RF) signals propagate over more than one path from the transmitter to the receiver. Alternate paths with different propagation times are created when the RF signal reflects from objects that are displaced from the direct path. The direct and alternate path signals sum at the receiver antenna to cause constructive and destructive interference, which have peaks and nulls. When the receiver antenna is positioned in a null, received signal strength drops and the communication channel is degraded or lost. The reflected signals may experience a change in polarization relative to the direct path signal. This multipath environment is typical of indoor and in-office wireless local area networks (WLAN).

[0005] An approach to addressing the multipath problem is to employ multiple receiver antenna elements in order to selectively receive a signal from more than one direction or from a slightly different position. This approach, known as "diversity", is achieved when receiving signals at different points in space or receiving signals with different polarization. Performance is further enhanced by isolating the separate antennas. Wireless communication link bit error rate (BER) performance is improved in a multipath environment if receive and/or transmit diversity is used.

[0006] Conventional antenna structures that employ diversity techniques tend to be expensive and physically large structures that utilize bulky connectors, such as coaxial cable connectors. Such antenna structures are not suitable for residential and office use where low-cost and small physical size are highly desirable characteristics. Furthermore, such antenna structures cannot be easily mounted or attached to the numerous different types of devices that may need to communicate in a WLAN. Thus, there is a need for antenna structures capable of employing diversity techniques that overcomes these and other disadvantages.

SUMMARY OF THE INVENTION

[0007] The present invention advantageously addresses the needs above as well as other needs by providing an antenna assembly that includes a portion of a first wall of a housing and a portion of a second wall of the housing. The first and second walls are noncoplanar. At least two antenna elements are included with a first of the at least two antenna elements being attached to the portion of the first wall and a second of the at least two antenna elements being attached to the portion of the second wall. Active circuitry is attached to a backside of at least one of the portion of the first wall and the portion of the second wall. The active circuitry is coupled to the at least two antenna elements.

[0008] In another embodiment, the invention can be characterized as an antenna assembly that includes a base having first and second plates that are noncoplanar and that are

joined together. At least two antenna elements are included with a first of the at least two antenna elements being attached to the first plate and a second of the at least two antenna elements being attached to the second plate. Active circuitry is attached to a backside of at least one of the first and second plates. The active circuitry is coupled to the at least two antenna elements.

[0009] In a further embodiment, the invention can be characterized as a method that includes a method of making an antenna assembly. The method of making an antenna assembly includes the steps of: forming a base having first and second plates that are noncoplanar and that comprises a shape that conforms to a portion of a housing; attaching at least two antenna elements to the base with a first of the at least two antenna elements being located on a front side of the first plate and a second of the at least two antenna elements being located on a front side of the second plate; attaching active circuitry to a back side of at least one of the first and second plates; and coupling the active circuitry to the at least two antenna elements.

BRIEF DESCRIPTION OF THE DRAWINGS

[0010] The above and other aspects, features and advantages of the present invention will be more apparent from the following more particular description thereof, presented in conjunction with the following drawings wherein:

[0011] **FIG. 1** is a perspective view illustrating a device housing having an antenna assembly incorporated therein in accordance with another embodiment of the present invention;

[0012] **FIG. 2** is a perspective view illustrating a device housing having an antenna assembly incorporated therein in accordance with another embodiment of the present invention;

[0013] **FIG. 3** is a perspective view illustrating the backside of the antenna assembly shown in **FIG. 2**;

[0014] **FIGS. 4A and 4B** are cross sectional diagrams illustrating exemplary transmission line techniques that may be used with the antenna assembly shown in **FIG. 3**;

[0015] **FIG. 5** is a perspective view illustrating a device housing having an antenna assembly incorporated therein in accordance with another embodiment of the present invention;

[0016] **FIG. 6** is a perspective view illustrating a device housing having an antenna assembly incorporated therein in accordance with another embodiment of the present invention;

[0017] **FIG. 7** is a perspective view illustrating the backside of the antenna assembly shown in **FIG. 6**;

[0018] **FIG. 8** is a perspective view illustrating an antenna assembly in accordance with another embodiment of the present invention;

[0019] **FIG. 9** is a perspective view illustrating the backside of the antenna assembly shown in **FIG. 8**;

[0020] **FIG. 10** is a perspective view illustrating the backside of the antenna assembly shown in **FIG. 8** with additional optional features; and

[0021] FIG. 11 is a flowchart illustrating a method of making and providing an antenna assembly in accordance with another embodiment of the present invention.

[0022] Corresponding reference characters indicate corresponding components throughout the several views of the drawings.

DETAILED DESCRIPTION OF THE INVENTION

[0023] The following description is not to be taken in a limiting sense, but is made merely for the purpose of describing the general principles of the invention. The scope of the invention should be determined with reference to the claims.

[0024] Referring to FIG. 1, there is illustrated an antenna assembly 100 made in accordance with an embodiment of the present invention. The antenna assembly 100 can be easily mounted or attached to numerous different types of devices that may need to communicate in a WLAN. Specifically, the antenna assembly 100 may be conveniently integrated into, or positioned on, portions of two or more walls or surfaces of a box or housing 102. In this way, the antenna assembly 100 conforms to the shape of a portion of the housing 102, and therefore, the antenna assembly 100 may be referred to as a conformal antenna. As illustrated, the antenna assembly 100 is particularly suited for placement on an edge 104 of the housing 102 where two non-coplanar walls or surfaces 110, 120 meet. It should be well understood that an edge of a housing may include a rounded, flat or otherwise irregular part of the housing where noncoplanar surfaces meet.

[0025] Although a generic box structure is illustrated, it should be well understood that the housing 102 may comprise a housing for nearly any type of device that may need to communicate wirelessly, such as for example, set-top boxes (including cable and XDSL), wireless local area network (WLAN) devices (including base stations, routers, repeaters, bridges), computers (including desktop, laptop, notebook, palmtop, and hand-held computers), information appliances, printers, fax machines, scanners, storage devices, televisions, stereos, thermostats, alarms (including burglar and fire alarms and associated sensors), household appliances (including washers, dryers, ovens, dishwashers, refrigerators), etc. The antenna assembly 100 can be used for performing wireless communications to and from any of these devices. Furthermore, the housing 102, as well as the other housings discussed herein, may comprise many different shapes and sizes. For example, the housings may have irregular surfaces with scattered flat regions where antenna elements could be situated.

[0026] The antenna assembly 100 is capable of achieving diversity and overcomes the disadvantages described above. It has good uniformity in signal strength in several directions, which makes it ideal for communicating with the numerous devices in a WLAN. It can be manufactured for very low cost and is extremely well suited to small form-factor applications that are to be used at high frequencies, including the 5 to 6 GHz frequency band. As will be discussed below, active circuitry, such as radio frequency (RF) circuitry, can be conveniently mounted on the backside of the antenna assembly 100. Such active circuitry may comprise separate or discrete components that are attached

to the backside of the antenna assembly 100, or the active circuitry may be integrated with all of the components of the antenna assembly 100.

[0027] A total of two or more antenna elements are preferably distributed across two or more non-coplanar surfaces of the housing 102. In the illustrated example, one or more antenna elements A_{t1} through A_{tn} are located on a portion of the top wall 110 of the housing 102, and one or more antenna elements A_{s1} through A_{sn} are located on a portion of the side wall 120 of the housing 102. Thus, the total of two or more antenna elements may be comprised of one or more antenna elements located on the top wall 110 and one or more antenna elements located on the side wall 120. The antenna elements are preferably located on the outer surface (or front side) of the walls 110, 120.

[0028] The cloud-like shape of the antenna elements A_{t1} through A_{tn} and A_{s1} through A_{sn} is intended to indicate that many different types of antennas may be used for implementing the antenna elements A_{t1} through A_{tn} and A_{s1} through A_{sn} . By way of example, patch antennas and/or monopole antennas may be used. Such monopole antennas may comprise vertical and/or horizontal monopole antennas. Furthermore, different types of antennas may even be used among the antenna elements A_{t1} through A_{tn} and A_{s1} through A_{sn} .

[0029] As mentioned above, the antenna assembly 100 is capable of achieving diversity. Specifically, spatial diversity can be achieved by spacing individual antenna elements apart so as to obtain sufficient decorrelation. Sufficient spacing of the individual antenna elements is important for obtaining minimum uncorrelated fading of antenna outputs. Preferably, at least some of the antenna elements A_{t1} through A_{tn} and A_{s1} through A_{sn} are spaced apart by a distance greater than or equal to 0.5λ for a frequency of operation falling within the 5 to 6 GHz frequency band. Because λ is so small for the 5 to 6 GHz frequency band, such spacing of antenna elements can be accomplished even when the housing 102 is relatively small, e.g., a housing for a hand held computer.

[0030] Polarization diversity can be achieved with the antenna assembly 100 when the polarizations of at least two of the antenna elements A_{t1} through A_{tn} and/or A_{s1} through A_{sn} are orthogonal to each other. Polarization diversity may be achieved in the present invention by using a combination of vertically and horizontally polarized antenna elements, or by positioning an active edge of one antenna element to be orthogonal to an active edge of another antenna element. For example, in a scenario where the two walls 110, 120 form a right angle (90°), the polarizations of the antenna elements A_{t1} through A_{tn} could be orthogonal to the polarizations of the antenna elements A_{s1} through A_{sn} .

[0031] The antenna assembly 100, as well as other antenna assemblies described herein, are capable of achieving a high amount of diversity per unit volume by using simple antenna structures that can be hosted in a small form factor. Some embodiments of the present invention use a combination of spatial and polarization diversity to achieve a high number of reasonably uncorrelated antenna elements in the small form factor. It should be well understood, however, that some embodiments of the present invention may rely solely on spatial diversity and that some embodiments of the present invention may rely solely on polarization diversity.

[0032] When receiving a signal in a multi-path environment, the signal offered to the receiver contains not only a direct line-of-sight radio wave, but also a large number of reflected radio waves, which interfere with the direct wave to create a “composite signal.” Two or more of the antenna elements A_{t1} through A_{tn} and A_{s1} through A_{sn} each receive this “composite signal.” Each of these “composite signals” comprises a sum of the direct and alternate path signals, as well as signals that experience a change in polarization, which constructively and destructively interfere and create peaks and nulls. By relying on spatial diversity, polarization diversity, or a combination of both spatial and polarization diversity, the antenna assembly **100** can compensate for fading because several replicas of the same information carrying signal are received over multiple channels by different antenna elements. There is a good likelihood that at least one or more of these received signals will not be in a fade at any given instant in time, thus making it possible to deliver an adequate signal level to the receiver.

[0033] Because two or more of the antenna elements A_{t1} through A_{tn} and A_{s1} through A_{sn} are largely uncorrelated, more than one power amplifier stage in the transmitter can be used, thereby reducing the maximum power level required out of any individual power amplifier stage. This is highly advantageous for Orthogonal Frequency Division Multiplexing (OFDM) where the peak-to-average power ratio is a concern. Specifically, the FCC limits the total transmit power allowed, so this peak can be shared if there is more than one power amplifier stage involved.

[0034] Referring to FIG. 2, there is illustrated an antenna assembly **200** made in accordance with another embodiment of the present invention. In this embodiment, a total of six antenna elements **230**, **232**, **234**, **236**, **238** and **240** are mounted on a housing **202**. Three antenna elements **230**, **232**, **234** are mounted on a portion of a top wall **210** of the housing **202**, and three antenna elements **236**, **238**, **240** are mounted on a portion of a side wall **220** of the housing **202**. While this embodiment includes a total of six antenna elements, the present invention is not limited to the use of six antenna elements and is intended to include the use of two or more antenna elements. Furthermore, the antenna elements **230**, **232**, **234**, **236**, **238** and **240** may be distributed across the top and side walls **210**, **220** in any manner just so long as at least one antenna element is located on the top wall **210** and at least one antenna element is located on the side wall **220**. In other words, the present invention is not limited to the use of three antenna elements per wall. The antenna elements **230**, **232**, **234**, **236**, **238** and **240** are preferably located on the outer surface (or front side) of the walls **210**, **220**. As with the housing **102** discussed above (FIG. 1), the housing **202** may be part of many different types of devices.

[0035] Traditional patch antennas or printed microstrip antenna elements are a very cost-effective way to realize one or more of the individual antenna elements **230**, **232**, **234**, **236**, **238**, **240**. In this embodiment, all six of the antenna elements **230**, **232**, **234**, **236**, **238**, **240** are implemented with patch antennas. Many different types of patch antennas may be used, including $\frac{1}{4}$ -wave, $\frac{1}{2}$ -wave and $\frac{3}{4}$ -wave patch antennas. It should be well understood that other types of antennas may be used to realize one or more of the individual antenna elements **230**, **232**, **234**, **236**, **238**, **240** in accordance with the present invention.

[0036] Printed copper (microstrip) techniques may be used to implement the patch antenna elements **230**, **232**, **234**, **236**, **238**, **240**. For example, the outer surface of the housing **202** may include metal patterns that define the structure of the patch antenna elements **230**, **232**, **234**, **236**, **238**, **240**, and the inner surface of the housing **202** can be metalized to provide a ground plane **204**. By way of example, the ground plane **204** may comprise copper plating. The ground plane **204** is typically located on the inner surface of the housing **202** behind the antenna elements **230**, **232**, **234**, **236**, **238**, **240**. This kind of construction is extremely low-cost and low-profile.

[0037] The detailed design process for an individual patch antenna is well known. Each of the antenna elements **230**, **232**, **234**, **236**, **238**, **240** is preferably individually designed to have good gain and Voltage Standing Wave Ratio (VSWR). This is standard procedure in antenna design. In addition, the individual antenna element designs are preferably optimized to preserve good gain and VSWR while also delivering good inter-element isolation. In other words, the antenna elements are preferably designed to exhibit acceptably low cross-correlation (i.e., isolation). Good isolation is important for achieving good diversity gain. Thus, each of the antenna elements **230**, **232**, **234**, **236**, **238**, **240** preferably provides gain while also having good isolation between itself and other antenna elements.

[0038] The separate antenna elements **230**, **232**, **234**, **236**, **238**, **240** are capable of offering spatial and/or polarization diversity, which delivers good receive and transmit diversity performance. As mentioned above, spatial diversity can be achieved by appropriately spacing two or more of the individual antenna elements **230**, **232**, **234**, **236**, **238**, **240** so as to obtain sufficient decorrelation. Polarization diversity can be achieved by making the polarizations of at least two of the antenna elements **230**, **232**, **234**, **236**, **238**, **240** orthogonal to each other. For example, in a scenario where the two walls **210**, **220** form a right angle (90°), the polarizations of the antenna elements **230**, **232**, **234** would be orthogonal to the polarizations of the antenna elements **236**, **238**, **240**. The antenna assembly **200** is very convenient for application in the 5 to 6 GHz frequency band where low-cost and antenna diversity is desired.

[0039] Referring to FIG. 3, active circuitry **250** can be conveniently located within the housing **202** on the underside of the antenna assembly **200**. By way of example, the active circuitry **250** may comprise power amplifiers for driving the antenna elements, low noise amplifiers (LNAs) for amplifying the received signals, RF switches for selecting signals routed to and from transmit and receive antenna elements, and/or digital baseband processing application specific integrated circuits (ASICs). The active circuitry **250** may also comprise additional circuitry that processes the transmitted and received signals, for example frequency translation from/to an intermediate frequency (IF) to/from the final radio frequency (RF) frequency. The active circuitry **250** may comprise some or all of the circuitry that is needed for the antenna elements **230**, **232**, **234**, **236**, **238**, **240**. In other words, additional circuitry that is needed for the antenna elements **230**, **232**, **234**, **236**, **238**, **240** may be located elsewhere in the housing **202**. The active circuitry **250** may be attached to the backside of either one or both of the walls **210**, **220**. Furthermore, the active circuitry **250**

may comprise separate or discrete components, or the active circuitry **250** may be integrated with all of the components of the antenna assembly **200**.

[0040] The active circuitry **250** may be mounted on the ground plane **204** using an appropriate means for isolating the active circuitry **250** from the ground plane **204**.

[0041] Locating the active circuitry **250** on the backside of the antenna assembly **200** has the advantage of allowing the active circuitry **250** to interface directly with the antenna elements **230, 232, 234, 236, 238, 240**, which simplifies signal routing and eliminates the need for coaxial antenna connections. Such location places the active circuitry **250** intimately close to the antenna elements **230, 232, 234, 236, 238, 240**, which minimizes signal losses. Traces **260** may be used to directly interface the antenna elements **230, 232, 234, 236, 238, 240** with the active circuitry **250**. Because the active circuitry **250** is intimately close to the antenna elements **230, 232, 234, 236, 238, 240**, the traces **260** can be very short, which means that the antenna elements **230, 232, 234, 236, 238, 240** are connected almost immediately to the active circuitry **250**. Short trace lengths are highly advantageous when operating at very high frequencies, such as 5 GHz, due to the losses that can occur with long traces. Preferably, trace lengths of less than or equal to 0.5 to 1.0 inches are used.

[0042] The traces **260** provide a cost-effective means of routing both the transmit and receive signals to and from each of the antenna elements **230, 232, 234, 236, 238, 240**. The traces **260** may be implemented using many different techniques, including microstrip or other transmission line methods. For example, referring to FIG. 4A, the traces **260** may comprise a coplanar feed structure **270**. A coplanar feed structure is very attractive because it is low-cost to implement. A coplanar feed structure does not use a ground plane. Instead, the signals are propagated along a center conductor **271** using a pair of ground conductors **272** with controlled geometry to maintain substantially constant transmission line impedance. The conductors **271, 272** may be formed on the wall **274** of the housing **202**. The conductors **271, 272** may comprise copper or other metal, and the wall **274** may comprise plastic or other dielectric.

[0043] As another example, referring to FIG. 4B, the traces **260** may comprise a microstrip feed structure **280**. A microstrip feed structure uses a single conductor **282** with a ground plane **284**. The single conductor **282** is located on one side of the wall **274**, and the ground plane **284** is located on the other side of the wall **274**. The single conductor **282** and the ground plane **284** may comprise copper or other metal.

[0044] In other embodiments of the present invention, the antenna elements are distributed over more than two non-coplanar walls or surfaces. For example, referring to FIG. 5 there is illustrated an antenna assembly **300** made in accordance with another embodiment of the present invention. The antenna assembly **300** includes antenna elements that are distributed over three non-coplanar walls of a housing **302**. Specifically, the antenna assembly **300** is capable of being located generally at the point of intersection of three non-coplanar walls **310, 320, 330**, or in other words, at a corner of the housing **302**. As with the housing **102** discussed above (FIG. 1), the housing **302** may be part of many different types of devices.

[0045] A total of three or more antenna elements are preferably distributed across the three non-coplanar walls **310, 320, 330** of the housing **302**. In the illustrated example, one or more antenna elements A_{b1} through A_{bn} are located on a portion of the first wall **310**, one or more antenna elements A_{c1} through A_{cn} are located on a portion of the second wall **320**, and one or more antenna elements A_{d1} through A_{dn} are located on a portion of a third wall **330**. Thus, the total of three or more antenna elements may be comprised of one or more antenna elements located on the first wall **310**, one or more antenna elements located on the second wall **320**, and one or more antenna elements located on the third wall **330**. In other words, there is at least one antenna element located on each wall **310, 320, 330**. The antenna elements are preferably located on the outer surface (or front side) of the walls **310, 320, 330**. As above, the cloud-like shape of the antenna elements is intended to indicate that many different types of antennas may be used among the antenna elements A_{b1} through A_{bn} , A_{c1} through A_{cn} , and A_{d1} through A_{dn} .

[0046] As with the antenna assembly **100** discussed above (FIG. 1), the antenna assembly **300** is capable of achieving diversity. Specifically, the antenna assembly **300** is capable of achieving spatial diversity and/or polarization diversity in the manner described above. Furthermore, the use of antenna elements on three non-coplanar walls instead of just two non-coplanar walls advantageously increases the number of directions in which the antenna assembly **300** has good uniformity in signal strength.

[0047] Referring to FIG. 6, there is illustrated an antenna assembly **400** made in accordance with yet another embodiment of the present invention. In this embodiment, six separate antenna elements **410, 420, 430, 440, 450, 460** are mounted near a corner of a housing **402**. Two antenna elements **410, 420** are mounted on a portion of a first wall **408** of the housing **402**, two antenna elements **430, 440** are mounted on a portion of a second wall **404** of the housing **402**, and two antenna elements **450, 460** are mounted on a portion of a third wall **406** of the housing **402**. While this embodiment includes six antenna elements, the present invention is not limited to the use of six antenna elements. Furthermore, as with the housing **102** discussed above (FIG. 1), the housing **402** may be part of many different types of devices.

[0048] In this embodiment, all six of the antenna elements **410, 420, 430, 440, 450, 460** are implemented with patch antennas. In order to illustrate that many different types of antennas may be used, it is noted that the illustrated patch antenna elements **450, 460** have a feed point from a ground plane layer beneath the patch and that the patch antenna elements **410, 420, 430, 440** have an inset feed. As mentioned above, however, it should be well understood that many different types of antennas may be used in accordance with the present invention.

[0049] A ground plane **404** is positioned on the inside of the housing **402** behind the antenna elements **410, 420, 430, 440, 450, 460**. By way of example, the ground plane **404** may comprise copper plating. Similar to as described above, each of the antenna elements **410, 420, 430, 440, 450, 460** is preferably individually designed to have good gain and VSWR while also delivering good inter-element isolation, which helps to achieve good diversity gain. This configu-

ration is also very convenient for application in the 5 to 6 GHz frequency band where low-cost and antenna diversity is desired.

[0050] The antenna elements **410, 420, 430, 440, 450, 460** are capable of achieving spatial and/or polarization diversity as described above. This helps to deliver good receive and transmit diversity performance. Spatial diversity can be achieved by appropriately spacing two or more of the individual antenna elements **410, 420, 430, 440, 450, 460** so as to obtain sufficient decorrelation. Polarization diversity can be achieved by making the polarizations of at least two of the antenna elements **410, 420, 430, 440, 450, 460** orthogonal to each other. For example, assuming that the two walls **404, 408** form a right angle (90°), the polarizations of the antenna elements **410, 420** would be orthogonal to the polarizations of the antenna elements **430, 440**. By way of further example, the active (radiating) edges **452, 454** of the patch antenna **450** could be purposely chosen to be orthogonal to the polarization present on the edges of the antenna element **460**. Such orthogonality helps to achieve polarization diversity.

[0051] Referring to **FIG. 7**, some or all of the active circuitry **470**, such as RF circuitry, can be conveniently located within the housing **402** on the underside of the antenna assembly **400**. As discussed above, the active circuitry **470** may comprise circuitry to perform many signal processing related functions. Locating the active circuitry **470** on the backside of the antenna assembly **400** allows the active circuitry **470** to interface directly with the antenna elements **410, 420, 430, 440, 450, 460**, which simplifies signal routing, eliminates the need for coaxial antenna connections, and minimizes signal loss due to the close proximity of the active circuitry **470** with the antenna elements. The active circuitry **470** may be attached to the backside of either one, two or all three of the walls **404, 406, 408**. Furthermore, the active circuitry **470** may comprise separate or discrete components, or the active circuitry **470** may be integrated with all of the components of the antenna assembly **400**.

[0052] Traces **480** may be used to directly interface the antenna elements **410, 420, 430, 440, 450, 460** with the active circuitry **470**. The traces **480** may be implemented using many different techniques, including the coplanar feed structure and microstrip feed structure described above (**FIGS. 4A and 4B**).

[0053] Referring to **FIG. 8**, there is illustrated an antenna assembly **500** made in accordance with yet another embodiment of the present invention. The antenna assembly **500** comprises a self contained unit that can be joined with, or removed from, device housings. For example, the antenna assembly **500** can be easily added-on to a housing **502** by fitting the antenna assembly **500** into an opening **503** in the housing **502**. This "add-on" capability advantageously allows the antenna assembly **500** to be provided as a working wireless unit that can be added to an assembly-ready product, such as for example, a set-top box, computer, or other device. In this scenario, for example, one manufacturer could provide the antenna assembly **500** to another manufacturer that would simply "drop" it into their assembly-ready product. Because the antenna assembly **500** can in some embodiments conform to the surface of the housing **502**, it may be referred to as a removable or add-on applique antenna assembly.

[0054] The antenna assembly **500** includes a conformal base **510** having a shape generally corresponding to a portion of the housing **502** to which the antenna assembly **500** is to be mounted. In this embodiment, the base **510** comprises a shape corresponding to the opening **503** in the housing **502**. Four antenna elements **520, 530, 540, 550** are mounted on the base **510**, and all four antenna elements **520, 530, 540, 550** are implemented with patch antennas. The base **510** includes two non-coplanar surfaces or plates **504, 506**. Two antenna elements **520, 550** are mounted on the first plate **504**, and two antenna elements **530, 540** are mounted on the second plate **506**. The antenna elements are preferably located on the outer surfaces (or front sides) of the plates **504, 506**. It should be well understood that the number of antenna elements is not limited to four and that other types of antennas may be used in accordance with the present invention.

[0055] Although in this embodiment the base **510** is shown as having two non-coplanar plates **504, 506** that conform to the shape of the edge of the housing **502**, other embodiments of the present invention may include a base having three non-coplanar surfaces or plates so as to conform with a corner of a device housing. In such a corner application, the antenna elements could be distributed over the conformal base in a manner similar to the distribution of antenna elements in the antenna assemblies **300, 400** (**FIGS. 5, 6**). As mentioned above, an edge of a housing may include a rounded, flat or otherwise irregular part of the housing where noncoplanar surfaces meet.

[0056] The first and second plates **504, 506** of the base **510** include metal patterns that define the structure of the antenna elements **520, 530, 540, 550**. A ground plane **508** is positioned on the other side of the base **510** behind the antenna elements **520, 530, 540, 550**. By way of example, the base **510** can be made of metalized plastic with the metalized surface being used to provide the ground plane **508**. It should be well understood, however, that the base **510** may be made from many different types of materials. Similar to as described above, each of the antenna elements **520, 530, 540, 550** is preferably individually designed to have good gain and VSWR while also delivering good inter-element isolation, which helps to achieve good diversity gain.

[0057] As described above, spatial diversity can be achieved by appropriately spacing two or more of the individual antenna elements **520, 530, 540, 550** so as to obtain sufficient decorrelation. Polarization diversity can be achieved by making the polarizations of at least two of the antenna elements **520, 530, 540, 550** orthogonal to each other. For example, in a scenario where the two plates **504, 506** form a right angle (90°), the polarizations of the antenna elements **520, 550** would be orthogonal to the polarizations of the antenna elements **530, 540**.

[0058] Referring to **FIG. 9**, some or all of the active circuitry **570**, such as RF circuitry, can be conveniently located on the underside (or backside) of the base **510**. As discussed above, the active circuitry **570** may comprise circuitry to perform many signal processing related functions. For example, the active circuitry **570** may comprise an operable transceiver, which could allow the antenna assembly **500** to be provided as a working wireless unit. Locating the active circuitry **570** on the backside of the base **510** allows the active circuitry **570** to interface directly with the

antenna elements **520, 530, 540, 550**, which simplifies signal routing, eliminates the need for coaxial antenna connections, and minimizes signal loss due to the close proximity of the active circuitry **570** with the antenna elements. The active circuitry **570** may comprise separate or discrete components that are attached to the base **510**, or the active circuitry **570** may be integrated with all of the components of the antenna assembly **500**. As illustrated, the active circuitry **570** is not mounted on the ground plane **508**, but it is contemplated that in other embodiments the active circuitry **570** could be mounted on the ground plane **508**. Furthermore, the active circuitry **570** could be attached to the backside of either one or both of the plates **504, 506**.

[0059] Many different techniques may be used to directly interface the antenna elements **520, 530, 540, 550** with the active circuitry **570** and for routing transmit and receive signals. Such techniques include the coplanar feed structure and microstrip feed structure described above (FIGS. 4A and 4B). In the illustrated example, the antenna element **540** is directly interfaced with the active circuitry **570** using a coplanar feed structure **580**. Specifically, the coplanar feed structure **580** includes ground paths **582** and a center conductor **584**. The ground paths **582** may be connected to the ground plane **508** with via connections **586**. The center conductor **584** may be connected to the top-side microstrip of the antenna element **540** with a via connection **588** and the appropriate coplanar-to-microstrip impedance transition. The ground paths **582** and the center conductor **584** may be routed along the backside of the surface **506** to the active circuitry **570**. Similar connections may be made to the other antenna elements **520, 530, 550**. It should be well understood that this is just one exemplary manner of coupling the antenna elements to the active circuitry **570** and that many other types of connections may be used in accordance with the present invention.

[0060] It was mentioned above that more than one power amplifier stage in the transmitter can be used, which reduces the maximum power level required out of any individual power amplifier stage. Making the polarizations of at least two antenna elements orthogonal to each other permits separate transmitter power amplifier stages to drive each of the two polarizations, thereby lowering the required power amplifier output power (per branch) by 3 dB. For example, referring to FIG. 10, in the scenario where the polarizations of the antenna elements **520, 550** are orthogonal to the polarizations of the antenna elements **530, 540**, the active circuitry **570** could include one transmitter power amplifier stage **572** for driving the antenna elements **530, 540** and a separate transmitter power amplifier stage **574** for driving the antenna elements **520, 550**. This can help reduce the required power amplifier output power while delivering the same total output power level.

[0061] It was suggested above that because of the “add-on” capability of the antenna assembly **500**, one entity could manufacture or assemble the antenna assembly **500** and provide it to another entity or manufacturer that would simply “drop” it into an assembly-ready product. FIG. 11 illustrates a method **600** in accordance with one embodiment of the present invention. Steps **602, 604, 606** and **608** comprise a method of making the antenna assembly **500** in accordance with one embodiment of the present invention. Specifically, in step **602** the base **510** is formed to have first and second plates **504, 506** that are noncoplanar. The base

510 is preferably formed so that it comprises a shape that conforms to a portion of a housing to which attachment is to eventually occur, such as the housing **502**. In step **604** at least two antenna elements are attached to the base **510**. A first of the at least two antenna elements, such as antenna element **520**, is located on a front side of the first plate **504**, and a second of the at least two antenna elements, such as antenna element **530**, is located on a front side of the second plate **506**. In step **606** the active circuitry **570** is attached or integrated onto a back side of at least one or both of the first and second plates **504, 506**. In step **608** the active circuitry **570** is coupled to the at least two antenna elements, such as for example with a coplanar feed structure or a microstrip feed structure. It should be well understood that steps **602, 604, 606** and **608** do not have to be performed in the illustrated order and that one or more of these steps may be combined into an integration process whereby two or more steps are performed at the same time.

[0062] Either one, none, or both of steps **610** and **612** may be performed. Specifically, in step **610** the completed antenna assembly **500** is attached to a housing. In step **612** the completed antenna assembly **500** is provided to an entity that distributes a product having a housing for which the antenna assembly **500** is intended. If step **612** is performed, then in step **614** that entity attaches the antenna assembly **500** to the intended product housing.

[0063] The following United States patent applications are hereby fully incorporated into the present application by reference: U.S. patent application Ser. No. 09/693,465, filed Oct. 19, 2000, entitled DIVERSITY ANTENNA STRUCTURE FOR WIRELESS COMMUNICATIONS, by inventor James A. Crawford; and U.S. patent application Ser. No. 09/735,977, filed Dec. 13, 2000, entitled CARD-BASED DIVERSITY ANTENNA STRUCTURE FOR WIRELESS COMMUNICATIONS, by inventor James A. Crawford.

[0064] While the invention herein disclosed has been described by means of specific embodiments and applications thereof, numerous modifications and variations could be made thereto by those skilled in the art without departing from the scope of the invention set forth in the claims.

What is claimed is:

1. An antenna assembly, comprising:

a portion of a first wall of a housing;

a portion of a second wall of the housing, the first and second walls being noncoplanar;

at least two antenna elements with a first of the at least two antenna elements being attached to the portion of the first wall and a second of the at least two antenna elements being attached to the portion of the second wall; and

active circuitry attached to a backside of at least one of the portion of the first wall and the portion of the second wall, the active circuitry being coupled to the at least two antenna elements.

2. An antenna assembly in accordance with claim 1, wherein at least two of the at least two antenna elements are sufficiently spaced apart so as to achieve spatial diversity.

3. An antenna assembly in accordance with claim 1, wherein at least two of the at least two antenna elements are

spaced apart by a distance equal to or greater than 0.5λ for a predetermined frequency of operation.

4. An antenna assembly in accordance with claim 3, wherein the predetermined frequency of operation falls within 5 to 6 gigahertz (GHz).

5. An antenna assembly in accordance with claim 1, wherein at least one of the at least two antenna elements comprises a first polarization and at least one of the at least two antenna elements comprises a second polarization, wherein the first and second polarizations are orthogonal to each other so as to achieve polarization diversity.

6. An antenna assembly in accordance with claim 5, wherein the active circuitry comprises:

a first power amplifier configured to drive the first polarization; and

a second power amplifier configured to drive the second polarization.

7. An antenna assembly in accordance with claim 1, further comprising:

a ground plane attached to the backside of the portion of the first wall and the backside of the portion of the second wall.

8. An antenna assembly in accordance with claim 1, wherein one or more of the at least two antenna elements comprises a patch antenna.

9. An antenna assembly in accordance with claim 1, further comprising:

a portion of a third wall of the housing, wherein the first, second and third walls are noncoplanar; and

a third of the at least two antenna elements being attached to the portion of the third wall.

10. An antenna assembly in accordance with claim 9, wherein the portion of the first wall, the portion of the second wall and the portion of the third wall form a corner of the housing.

11. An antenna assembly, comprising:

a base having first and second plates that are noncoplanar and that are joined together;

at least two antenna elements with a first of the at least two antenna elements being attached to the first plate and a second of the at least two antenna elements being attached to the second plate; and

active circuitry attached to a backside of at least one of the first and second plates, the active circuitry being coupled to the at least two antenna elements.

12. An antenna assembly in accordance with claim 11, wherein the base comprises a shape that conforms to a portion of a housing.

13. An antenna assembly in accordance with claim 11, wherein at least two of the at least two antenna elements are sufficiently spaced apart so as to achieve spatial diversity.

14. An antenna assembly in accordance with claim 11, wherein at least two of the at least two antenna elements are spaced apart by a distance equal to or greater than 0.5λ for a predetermined frequency of operation.

15. An antenna assembly in accordance with claim 14, wherein the predetermined frequency of operation falls within 5 to 6 gigahertz (GHz).

16. An antenna assembly in accordance with claim 11, wherein at least one of the at least two antenna elements

comprises a first polarization and at least one of the at least two antenna elements comprises a second polarization, wherein the first and second polarizations are orthogonal to each other so as to achieve polarization diversity.

17. An antenna assembly in accordance with claim 16, wherein the active circuitry comprises:

a first power amplifier configured to drive the first polarization; and

a second power amplifier configured to drive the second polarization.

18. An antenna assembly in accordance with claim 11, further comprising:

a ground plane attached to the backside of the first and second plates.

19. An antenna assembly in accordance with claim 11, wherein one or more of the at least two antenna elements comprises a patch antenna.

20. A method that includes a method of making an antenna assembly, the method of making an antenna assembly comprising the steps of:

forming a base having first and second plates that are noncoplanar and that comprises a shape that conforms to a portion of a housing;

attaching at least two antenna elements to the base with a first of the at least two antenna elements being located on a front side of the first plate and a second of the at least two antenna elements being located on a front side of the second plate;

attaching active circuitry to a back side of at least one of the first and second plates; and

coupling the active circuitry to the at least two antenna elements.

21. A method in accordance with claim 20, further comprising the step of:

providing the antenna assembly to an entity that distributes a product having the housing.

22. A method in accordance with claim 20, further comprising the step of:

attaching the antenna assembly to the housing.

23. A method in accordance with claim 20, wherein the step of attaching at least two antenna elements to the base comprises the step of:

spacing at least two of the at least two antenna elements apart so as to achieve spatial diversity.

24. A method in accordance with claim 20, wherein the step of attaching active circuitry to a back side of at least one of the first and second plates comprises the step of:

integrating the active circuitry to a back side of at least one of the first and second plates.

25. A method in accordance with claim 20, wherein the step of attaching at least two antenna elements to the base comprises the step of:

spacing at least two of the at least two antenna elements apart by a distance equal to or greater than 0.5λ for a predetermined frequency of operation.

26. A method in accordance with claim 25, wherein the predetermined frequency of operation falls within 5 to 6 gigahertz (GHz).

27. A method in accordance with claim 20, wherein the step of attaching at least two antenna elements to the base comprises the steps of:

providing at least one of the at least two antenna elements with a first polarization; and

providing at least another of the at least two antenna elements with a second polarization;

wherein the first and second polarizations are orthogonal to each other so as to achieve polarization diversity.

28. A method in accordance with claim 27, wherein the active circuitry comprises:

a first power amplifier configured to drive the first polarization; and

a second power amplifier configured to drive the second polarization.

29. A method in accordance with claim 20, wherein the method of making an antenna assembly further comprises the step of:

forming a ground plane on the backsides of the first and second plates.

30. A method in accordance with claim 20, wherein one or more of the at least two antenna elements comprises a patch antenna.

* * * * *