

(No Model.)

2 Sheets—Sheet 1.

E. SALTZKORN & L. NICOLAI.
PASTEBOARD BOX MACHINE.

No. 455,767.

Patented July 14, 1891.

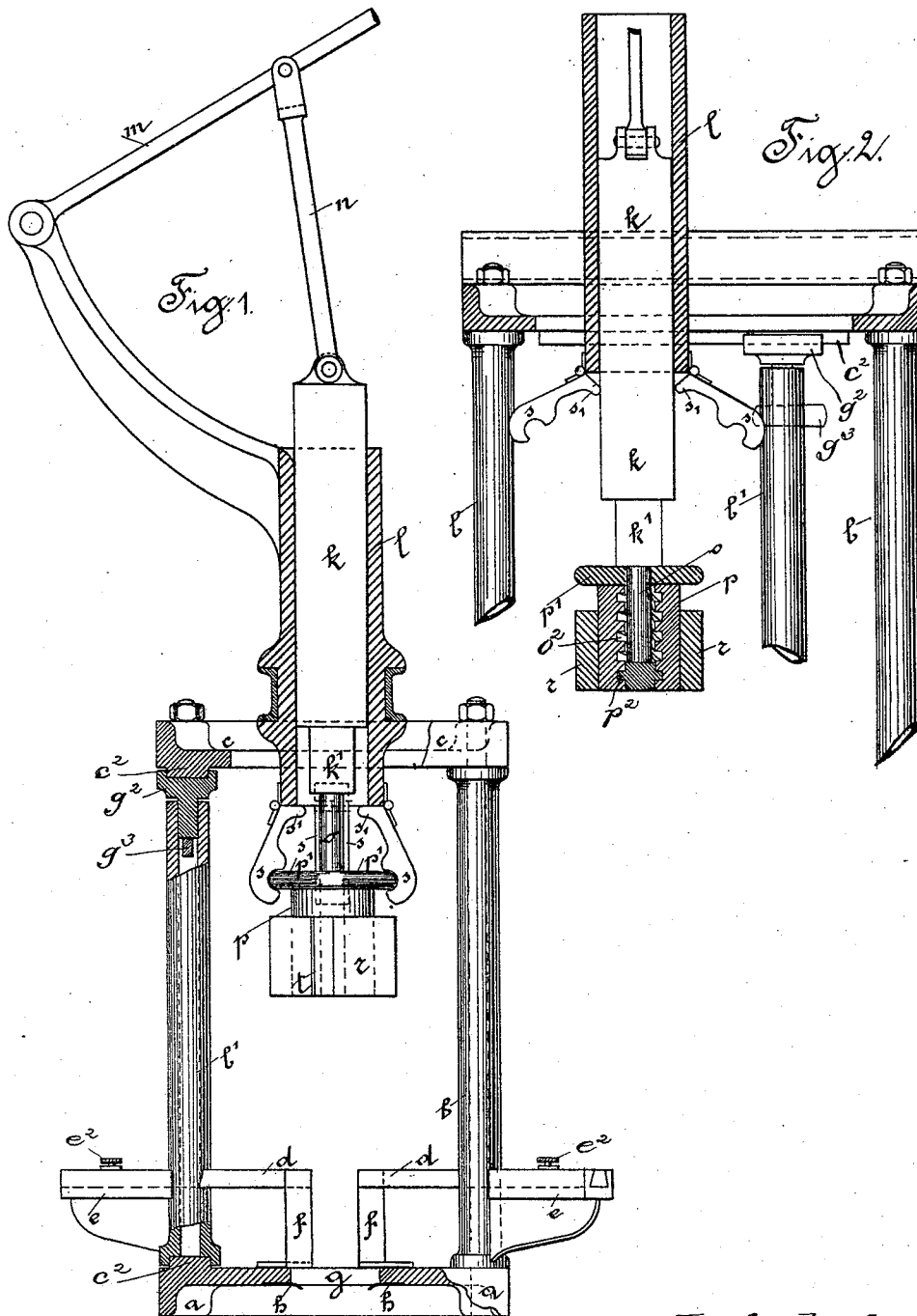

Witnesses
Thomas Durant.
E. R. Smith

Inventors
Emil Saltzkorn and
Ludwig Nicolai,
by
Clunck & Clunck
their Attys.

E. SALTZKORN & L. NICOLAI.
PASTEBOARD BOX MACHINE.

No. 455,767.

Patented July 14, 1891.

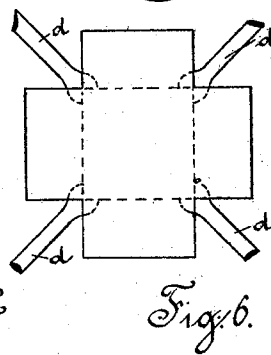
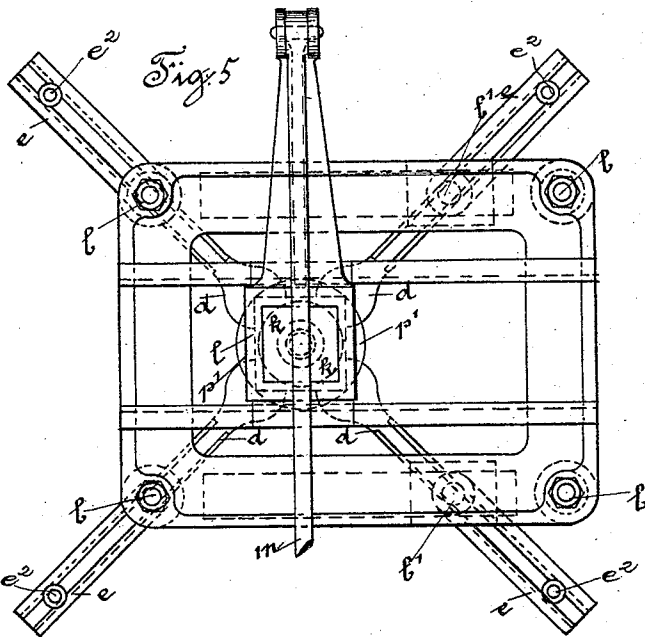
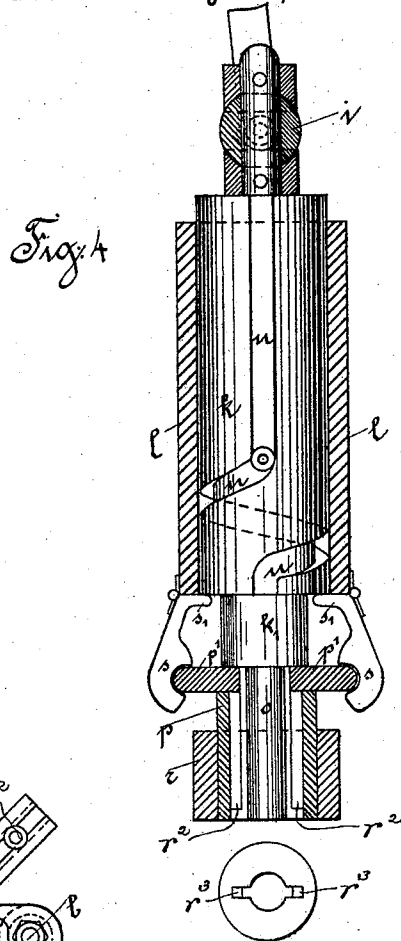
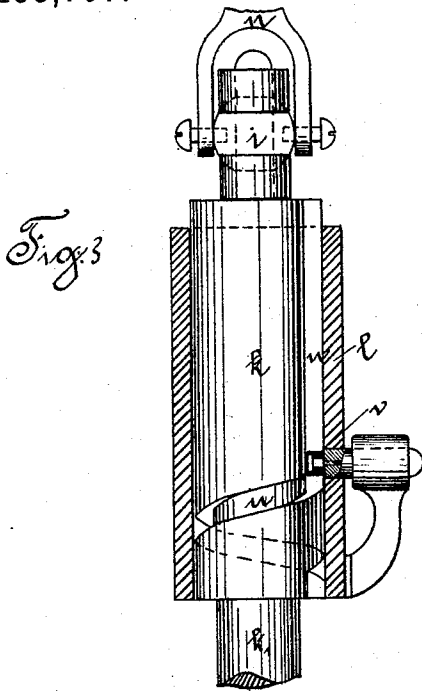

Witnesses.
 Thomas Durant
 C. H. Smith

Inventors
 Emil Saltzkorn and
 Ludwig Nicolai,
 by Church & Church
 Their Attys.

UNITED STATES PATENT OFFICE.

EMIL SALTZKORN AND LUDWIG NICOLAI, OF DRESDEN, GERMANY.

PASTEBOARD-BOX MACHINE.

SPECIFICATION forming part of Letters Patent No. 455,767, dated July 14, 1891.

Application filed May 22, 1890. Serial No. 352,738. (No model.)

To all whom it may concern:

Be it known that we, EMIL SALTZKORN and LUDWIG NICOLAI, subjects of the King of Saxony, and residents at the city of Dresden, in the Kingdom of Saxony, German Empire, have invented certain new and useful Improvements in Pasteboard-Box Machines, of which the following is a specification.

The object of the improved machine, according to our invention, is to manufacture boxes of card-board by machinery, and thereby to avoid the loss of time and uncleanness attending the folding of the card-board, the binding and sizing of the corners, and the lining the box with paper or a suitable fabric.

In the accompanying drawings, Figure 1 is a side view of the complete arrangement. Fig. 2 is a longitudinal section of the plunger and screw-nut. Figs. 3 and 4 are longitudinal sections of the cylindrical plunger provided with a groove and roller. Fig. 5 is a plan of the machine, and Fig. 6 shows the card-board blank lying on the angle-pieces.

On the table or platform *a* are mounted four uprights *b*, which support a superstructure or frame-head *c*, in which the plunger-cylinder is hung in such a manner as to be adjustable and at the same time capable of being retained in the desired position. Between the uprights *b* two additional uprights *b'* are arranged, which are mounted on ways *c'*, so as to be adjustable, and may also be fixed in position at will by means of the adjustable shoe *g'* and wedge-pin *g''*, the latter serving to push the shoe out and bind the upright in place. These uprights *b'*, in conjunction with two of the uprights *b*, carry the angle-pieces *d*, guided within the arms *e* on the uprights by means of dovetailed grooves and adapted to be fixed in position by means of adjusting-screws *e'*. At right angles to the angle-pieces are provided the guides *f*, reaching down to the opening *g*, formed in the table or platform. Below the latter a number of springs *h* are arranged so as to project into the open space *g* and adapted to slip the card-board box, when formed, off the frame. A plunger *k* is caused to move in the cylinder *l* by the lever *m*, to which it is connected through a link *n*. At the end of the plunger there is an extension *k'*, of a smaller diameter, which in its turn is joined by a spindle

o, carrying the nut *p* with the frame *r*. The disk *p'* on the top of the nut is adapted to be grasped by the grippers *s*, pivoted to the cylinder with the projecting portions *s'* extending over the opening of the cylinder.

In the arrangement, Figs. 3 and 4, the link *n* is attached to a ball *i*, whereby it is connected to the cylindrical plunger while permitting it to have an independent rotary movement, and in the plunger is formed a groove *u*, a portion of which is straight while the remaining portion assumes the shape of a screw-thread, said groove being adapted to co-operate with a roller *v* on the casing to cause the plunger to rotate, as will hereinafter appear. The disk *p'* is normally held below the projecting portion *k'* of the plunger, as in Fig. 1; but said plunger has a limited vertical movement independent of the nut and disk, and when lowered comes in contact with the disk. The vertical movement of the plunger is converted into a rotary movement of the nut and frame *r*. Thus in the instance under consideration and as shown in Figs. 3 and 4, the nut *p* is connected to the extension *o* by splines *r'* and grooves *r''*. Hence the rotary movement of the plunger is imparted to the frame *r*, while the vertical movement is not until the plunger releases the grippers.

In the frame *r* an inwardly-directed slit *t* is provided and the gummed or sized paper strip is inserted into this slit either by hand or by machinery and then held fast, and as the frame turns the required portion of it is cut off also by hand or machinery, as soon as it has been once wound about the frame. The slit *t* is open at its lower end so as to enable the paper strip to drop out of the frame as the box is removed therefrom.

A piece of card-board cut to the desired shape is placed upon the four adjustable angle-pieces *d*, as shown in Fig. 6, in such a manner that when the sides are bent up the box is formed it can slide down between them. For the purpose of adjusting these angle-pieces to accommodate different sizes of cases or boxes it is desired to manufacture, the holders of the said angle-pieces are movable in their guides and provided with suitable means for securing them in the desired position. Thus of the four guide-pieces provided for this purpose two are attached to

the before-mentioned adjustable uprights, which enables square or long boxes to be formed at will. The card-board blank, cut to the desired shape and lying upon the said angle-pieces, is intended at a given moment to be driven through these angle-pieces by the plunger, when the sides forming the walls of the box will be turned up into vertical position. The frame *r* on the plunger is of the same size as the bottom of the box it is desired to produce, and this frame is intended to strike the piece of card-board which is to form the bottom of the box at a point situated near the partial cut at the junction of the bottom and the side walls, and force the same down between the angle-pieces.

On the frame preparatory to its being used in the manner just described strips of paper or of a suitable fabric sized with size or glue are wound, preferably by machinery, as before described and in such a manner as that the side having the size upon it is turned outwardly. When the piece of card-board which is to form the box is forced through the angle-pieces, its sides adhere to these sized or gummed strips, and the springs arranged below the table or platform of the machine are adapted to be turned down as the box is forced through the angle-pieces, but press against the plunger-frame above the box, the result being that the box is slipped off the frame during the upward stroke of the plunger.

In every instance shown the plunger is provided with an extension of a smaller diameter terminating in a spindle, and the frame is fixed to a nut sliding upon the said spindle and carrying a disk at the top. A number of grippers are pivoted to the plunger-cylinder in such a manner that their angular pieces project over the opening of the cylinder, but do not reach the said extension of the plunger. Thus when the plunger is at rest these grippers grasp the edge of the disk of the screw-nut and retain the same in position in the frame; but when the plunger is pressed down by the lever the said grippers secure the disk at first, but at the same time allow of the rotation of the screw-nut with the frame, and the gummed or sized paper strip having been introduced into the slit of the frame beforehand is wound once round the frame as it rotates, and is then cut off. At that moment the thicker portion of the plunger has issued from the cylinder and presses upon the projecting angles of the grippers with the result that these grippers yield to the pressure laterally and release the disk, whereupon the nut, together with the frame and plunger, descend in a straight line and effect the movement described above for the purpose of pushing the "blank" of the box through the angle-pieces. As the plunger rises and at the moment when the thicker portion of the same re-enters the cylinders the said grippers are carried down by their own weight into their vertical position, and when the disk of the screw-nut again abuts against them, being

elevated by hand or otherwise, it is grasped by them, and the nut and frame are given a reverse rotary movement as the plunger continues its upward movement.

In the modification shown in Figs. 1 and 2 the spindle is provided with a screw-thread o^2 , and the nut is a true screw-nut being provided with a female thread p^2 , with which arrangement it will be seen at a glance that as the plunger and spindle descend, the nut and frame being held by the grippers is caused to rotate, and if the end of the pasted strip is inserted in the slit *t* it will be wound around the frame.

Having thus described my invention, what I claim as new is—

1. In a box-forming machine, the combination, with the angle-guides for the sides of the box, of the plunger and the rotary frame on the plunger working between the said guides, with means for securing a strip thereto for the inside of the box, substantially as described.

2. In a machine for forming boxes, the combination, with the guides for the sides of the box, of the plunger, the rotary frame loosely connected thereto to have a limited independent vertical movement and working between said guides, and a screw for rotating said frame, substantially as described.

3. In a machine for forming boxes, the combination, with the guides for the sides of the box, of the plunger, the rotary frame loosely connected thereto to have a limited independent vertical movement and working between said guides, a screw for rotating said frame, and grippers for holding the same against vertical movement while being rotated, substantially as described.

4. In a machine for forming boxes, the combination, with the guides for the sides of the box, of the plunger, the rotary frame loosely connected thereto to have a limited independent vertical movement and working between said guides, a screw for rotating said frame as the plunger descends, and grippers for holding the same against vertical movement while being rotated, said grippers having projections extending into the path of the plunger, whereby they are released automatically after the frame has been rotated, substantially as described.

5. In a machine for forming boxes, the combination, with the guides for the sides of the box, of the vertically-moving plunger, the rotary frame, and a screw connection between said frame and plunger, with means for holding said frame against vertical movement, whereby a rotary movement is imparted thereto by the movement of the plunger, substantially as described.

6. In a machine for forming boxes, the combination, with the guides for the sides of the boxes, of the vertically-movable plunger, the rotary frame connected thereto by a screw connection, the grippers for holding the frame against vertical movement, having the por-

tions projecting into the path of the plunger, whereby the initial movement of the plunger rotates the frame, then releases the grippers, and moves the frame vertically, substantially as described.

5 7. In a box-forming machine, the combination, with the vertically-movable plunger, of the guides for the sides of the box, mounted on adjustable uprights, substantially as described, whereby the length of the box may
10 be varied, substantially as described.

8. In a machine for forming boxes, the combination, with the vertically-movable plunger,

of the adjustable angle-guides for the corners of the box, two of said guides being
15 mounted in adjustable holders, whereby the width and length of the box may be varied, substantially as described.

In testimony whereof we affix our signatures in presence of two witnesses.

EMIL SALTZKORN.
LUDWIG NICOLAI.

Witnesses:

RÜDOLF COLSCHMIDT,
ERNEST LEHMANN.