



- (51) International Patent Classification:
A63B 5/11 (2006.01)
- (21) International Application Number:
PCT/NZ2012/000071
- (22) International Filing Date:
23 May 2012 (23.05.2012)
- (25) Filing Language: English
- (26) Publication Language: English
- (30) Priority Data:
61/488,854 23 May 2011 (23.05.2011) US
- (71) Applicant (for all designated States except US): **BOARD & BATTEN INTERNATIONAL INC**; c/- International Management Services, Harbour Centre, 4th Floor, North Church Street, Georgetown, BWI (KY).
- (72) Inventor; and
- (75) Inventor/Applicant (for US only): **MILLER, David Jethro** [NZ/NZ]; 230 Condell Avenue, 8053 Christchurch (NZ).
- (74) Agents: **WEST-WALKER, Greg, J et al.**; A J Park, PO Box 949, 6140 Wellington (NZ).
- (81) Designated States (unless otherwise indicated, for every kind of national protection available): AE, AG, AL, AM,

AO, AT, AU, AZ, BA, BB, BG, BH, BR, BW, BY, BZ, CA, CH, CL, CN, CO, CR, CU, CZ, DE, DK, DM, DO, DZ, EC, EE, EG, ES, FI, GB, GD, GE, GH, GM, GT, HN, HR, HU, ID, IL, IN, IS, JP, KE, KG, KM, KN, KP, KR, KZ, LA, LC, LK, LR, LS, LT, LU, LY, MA, MD, ME, MG, MK, MN, MW, MX, MY, MZ, NA, NG, NI, NO, NZ, OM, PE, PG, PH, PL, PT, QA, RO, RS, RU, RW, SC, SD, SE, SG, SK, SL, SM, ST, SV, SY, TH, TJ, TM, TN, TR, TT, TZ, UA, UG, US, UZ, VC, VN, ZA, ZM, ZW.

- (84) Designated States (unless otherwise indicated, for every kind of regional protection available): ARIPO (BW, GH, GM, KE, LR, LS, MW, MZ, NA, RW, SD, SL, SZ, TZ, UG, ZM, ZW), Eurasian (AM, AZ, BY, KG, KZ, RU, TJ, TM), European (AL, AT, BE, BG, CH, CY, CZ, DE, DK, EE, ES, FI, FR, GB, GR, HR, HU, IE, IS, IT, LT, LU, LV, MC, MK, MT, NL, NO, PL, PT, RO, RS, SE, SI, SK, SM, TR), OAPI (BF, BJ, CF, CG, CI, CM, GA, GN, GQ, GW, ML, MR, NE, SN, TD, TG).

Published:

- with international search report (Art. 21(3))
- before the expiration of the time limit for amending the claims and to be republished in the event of receipt of amendments (Rule 48.2(h))

- (54) Title: TRAMPOLINE ENCLOSURE WITH A SELF CLOSING DOOR

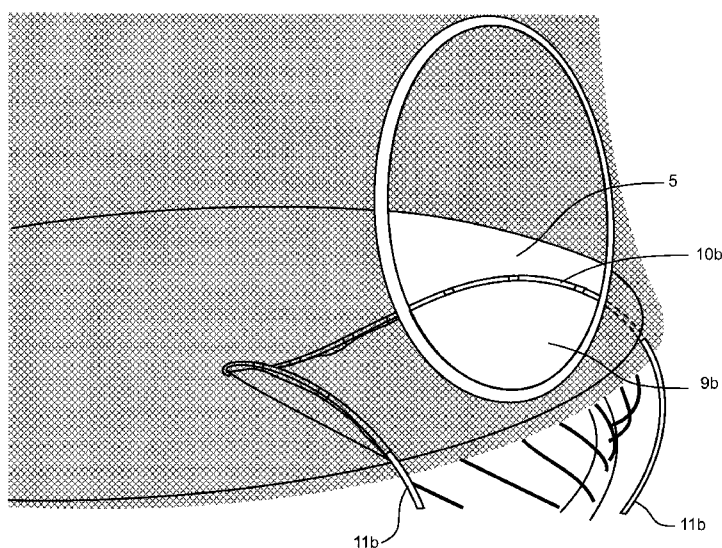

FIGURE 3B

- (57) Abstract: A trampoline enclosure formed from a material such as a netting has a door opening for entry into and exit from the trampoline enclosure and a fold down door panel with at least one resilient member acting to bias the door panel to return the door panel to a closed position from a folded down open position.



"TRAMPOLINE ENCLOSURE WITH A SELF CLOSING DOOR"**FIELD OF THE INVENTION**

5 The invention relates to a trampoline safety enclosure which has an opening for entry and exit by a user, and which further has a self closing door for the opening in the enclosure, and to a trampoline and safety enclosure in combination.

BACKGROUND

10 A trampoline in its most basic form generally comprises a rebounding mat fixed to a support frame so that the mat is supported above the ground. A user jumps or otherwise bounces on the mat. A trampoline may be equipped with a safety enclosure, which extends upwards from the mat to surround or enclose the rebounding mat to prevent a user from falling from the trampoline. Usually, the safety enclosure is attached to the trampoline around the edge of, and extends upwards from, the mat. Typically the
15 safety enclosure is formed from mesh or netting. The enclosure is supported in position by a number of poles which extend upwards from around the edge of the trampoline. Usually these poles are connected to the frame.

In order to access the rebounding mat, a user must pass from outside the enclosure to the inside. Usually, the enclosure has an access aperture or slot to facilitate
20 this. In one common form, the two adjacent ends of the enclosure overlap when the enclosure is 'wrapped' around the perimeter of the mat, the overlapping flaps forming a passageway that a user can move through, or which can be opened, to allow access. The adjacent ends are fastened closed by a zip or similar fastener. In another form the edges of the two adjacent ends of the enclosure meet to form a substantially vertical slit in the
25 netting. The slit may be fitted with a zip or similar fastening means to fasten the two edges together and close the slit if desired. A slit opening can also be created by cutting the enclosure.

SUMMARY OF THE INVENTION

30 It is an object of the invention to provide a trampoline safety enclosure with improved or at least alternative user entry and exit functionality.

In a first aspect the invention may broadly be said to consist in a trampoline system comprising:

- 35 a trampoline, having
- a flexible rebounding mat,
- a frame, adapted to hold the flexible rebounding mat in tension and aligned in a substantially horizontal plane above the frame,

an enclosure formed from a barrier of a flexible material, having a lower peripheral part coupled directly or indirectly to the mat,

a plurality of generally upright enclosure support members connected to the frame and extending upwards from the frame around the mat,

5 the enclosure connected to the support members so as to surround the mat above the mat and extend around the mat, the enclosure having, or being connected to the mat so as to form, an opening for ingress and egress,

the trampoline system further having a door system comprising:

10 at least one door panel, sized and shaped to at least partly cover or close the opening, and,

at least one resilient member associated with and connecting between the at least one door panel and the trampoline, the at least one door panel movable between an open position allowing ingress and egress, and a closed position where the door panel at least partly covers or closes the opening, the resilient member acting to bias the door panel to the closed position, and to return the door panel to the closed position from the open position.

Preferably the resilient door member is formed from a resiliently elastic material such as a pultruded fibreglass rod.

20 Preferably the resilient member is a rod, attached around at least part of the edge of the door panel, and most preferably all of the edge of the door panel except for the base of the door panel.

Preferably the two ends of the rod curve outwards to become substantially parallel to the horizontal plane of the rebounding mat, the ends connected to either the mat or the enclosure or both.

25 Alternatively the two ends of the rod extend downwards past the base of the door panel and past the edge of the mat to connect to the frame.

Preferably the frame and the rod are adapted so that the two free ends are connected to the frame to point inwards towards the frame, so that the lower part of the main body of the resilient member is bowed outwards away from the mat.

30 Preferably the resilient door member is formed as a straight rod, the door panel having at least one and preferably a plurality of pockets or loops on or close to the edge of the door, the rod bent and located into the at least one pocket or loop so as to run around the edge of the door panel, or close to the edge of the door panel.

35 Preferably the base of the door panel is connected to a component of the trampoline.

Even more preferably the door panel is connected to any one, or a combination of, the frame, the mat, or the enclosure.

Preferably the door panel is made from the same material as the mat.

Preferably the opening is substantially circular.

Alternatively the opening is substantially arch-shaped.

Preferably the perimeter of the opening is reinforced with a pultruded fibreglass rod.

5 Preferably the door system has a pair of door panels which overlap to cover or close the opening.

Preferably one of the door panels is located generally to the left of the aperture, and one to the right, each door having generally a 'D' shape and a curved main body, and a sloping straight back to the 'D' shape, with the bottom corner further away from the aperture than the top corner of the back of the 'D', the right-hand one of the pair reversed, 10 the doors sewn to the enclosure along the sloping part of the 'D' and at least partly along the top of the main body.

Preferably the main body of each door panel is formed from the same netting material as the enclosure.

15 Preferably each door panel has an associated resilient door member, fixed to edge of the door panel with at least one webbing loop or pocket that extends around the curved section.

Preferably the resilient member is formed from a resiliently elastic material such as a pultruded fibreglass rod.

20 Preferably the lower part of the end of the rod extends past the lower corner of the door panel along the perimeter of the mat.

Preferably the opening is substantially circular.

Alternatively the opening is substantially arch-shaped.

25 Preferably the perimeter of the opening is reinforced with a pultruded fibreglass rod.

Alternatively the door panel of the door system has a generally triangular shape with one upright edge of the door panel fixed to the enclosure to form a hinge, and the at least one resilient member is a rod fixed to the bottom edge of the door panel so as to run generally parallel to, and just above, the plane of the mat and extend along the lower edge 30 of the door panel.

Preferably the rod is a straight rod.

Preferably the rod is held in position against the edge of the mat by at least one loop or pocket and preferably a plurality of loops or pockets on the bottom of the door.

35 Preferably the rod extends beyond that corner of the door panel where the bottom edge meets the hinge edge, and is held in place on the trampoline by at least one pocket or loop connected to the trampoline.

Preferably the enclosure aperture is a triangular or sail-shaped opening in the enclosure, with one straight, sloped edge, one edge of the door congruent with the straight sloped edge of the aperture.

Preferably the door panel is made from the same material as the mat.

5 Preferably the door is fitted with a door lock comprising:

a plastic ball that is preferably attached to the trampoline, and most preferably attached to the enclosure at the perimeter or edge of the aperture via a short length of line or similar,

10 a slot in the door, the plastic ball pushed through the slot when the door is on the closed position, to hold the door closed.

In a second aspect the invention may broadly be said to consist in a door system for a trampoline enclosure having an opening for ingress and egress, the door system comprising:

15 at least one door panel, at least part of the periphery of the door panel forming an attachment edge adapted for attachment to a trampoline,

a resilient spring member attached around at least part of the periphery of the door panel, the resilient door member formed from a resiliently elastic material such as a pultruded fibreglass rod, at least one end of the rod extending past the edge of the door panel.

20 Preferably the attachment edge forms a base to the door panel, and the resilient rod is connected to the door panel around the remainder of the periphery, the two ends of the rod extending past the base edge for attachment to a trampoline.

25 Preferably the door panel has at least one pocket or loop around the remainder of the periphery of the door panel, the rod bent or otherwise located into the at least one pocket or loop.

Preferably the door panel has an arch shape.

Preferably the door panel has a 'D' shape with a curved main body and a sloping straight back, the sloping back forming the attachment edge, the resilient spring member attached around the periphery of the curved main body.

30 Preferably the resilient door member is connected to the edge of the door panel by at least one webbing loop or pocket around the curved section.

35 Alternatively the door panel has a generally triangular shape with one edge adapted for attachment to the enclosure to form a hinge, and the at least one resilient member is a straight rod fixed to an adjacent edge and extending beyond the corner where the adjacent edge and the hinge edge meet.

Preferably the rod is fixed to the adjacent edge by at least one loop or pocket on one edge of the door.

Preferably the rod extends beyond that corner of the door panel where the bottom edge meets the hinge edge, and is held in place on the trampoline by at least one pocket or loop connected to the trampoline.

5 Preferably the enclosure aperture is a triangular or sail-shaped opening in the enclosure, with one straight, sloped edge, one edge of the door congruent with the straight sloped edge of the aperture.

In a third aspect the invention may broadly be said to consist in a trampoline enclosure system for a trampoline having a planar horizontal jumping surface, the enclosure system comprising:

10 an enclosure formed from a barrier of a flexible material, the enclosure in use surrounding the trampoline jumping surface and extending upwards around the jumping surface, the enclosure having an opening for ingress and egress,

a door system having at least one door panel, sized and shaped to at least partly cover or close the opening, and at least one resilient member associated with the at least one door panel, the at least one door panel movable between an open position allowing ingress and egress, and a closed position where the door panel at least partly covers or closes the opening, the resilient member acting to bias the door panel to the closed position, and to return the door panel to the closed position from the open position.

15 Preferably the resilient door member is formed from a resiliently elastic material such as a pultruded fibreglass rod.

Preferably the resilient member is a rod, bent or shaped and in use connected to the trampoline so that the two ends of the rod extend downwards past the edge of the door panel, the rod attached around the edge of the door panel, except for the base of the door panel.

25 Preferably the resilient door member is formed as a straight rod, the door panel having at least one pocket or loop on or close to the edge of the door, the rod bent and located into the at least one pocket or loop so as to run around the edge of the door panel, or close to the edge of the door panel.

Preferably the opening is substantially circular.

30 Alternatively the opening is substantially arch-shaped.

Preferably the perimeter of the opening is reinforced with a pultruded fibreglass rod.

Preferably the door system has a pair of door panels which overlap to cover or close the opening.

35 Preferably one of the door panels is located generally to the left of the aperture, and one to the right, each door having generally a 'D' shape and a curved main body, and a sloping straight back to the 'D' shape, with the bottom corner further away from the aperture than the top corner of the back of the 'D', the right-hand one of the pair reversed,

the doors sewn to the enclosure along the sloping part of the 'D' and at least partly along the top of the main body.

Preferably the door panels and the enclosure are formed from the same material.

5 Preferably each door panel has an associated resilient door member, attached to the edge of the door panel by at least one webbing loop or pocket on or extending around the curved section.

Preferably the resilient member is formed from a resiliently elastic material such as a pultruded fibreglass rod.

10 Preferably the lower part of the end of the rod extends past the lower corner of the door panel.

Preferably the opening is substantially circular.

Alternatively the opening is substantially arch-shaped.

Preferably the perimeter of the opening is reinforced with a pultruded fibreglass rod.

15 Alternatively the door panel of the door system has a generally triangular shape with one upright edge of the door panel fixed to the enclosure to form a hinge, and the at least one resilient member is a rod fixed to the bottom edge of the door panel so as to run generally parallel to, and just above, the plane of the jumping surface in use and extend along the lower edge of the door panel.

20 Preferably the rod is a straight rod.

Preferably the rod extends beyond that corner of the door panel where the bottom edge meets the hinge edge.

25 Preferably the enclosure aperture is a triangular or sail-shaped opening in the enclosure, with one straight, sloped edge, one edge of the door congruent with the straight sloped edge of the aperture to form the hinge.

Preferably the door is fitted with a door lock comprising:

a plastic ball that is preferably attached to the trampoline, and most preferably attached to the enclosure at the perimeter or edge of the aperture via a short length of line or similar,

30 a slot in the door, the plastic ball pushed through the slot when the door is on the closed position, to hold the door closed.

The term "comprising" as used in this specification and indicative independent claims means "consisting at least in part of". When interpreting each statement in this specification and indicative independent claims that includes the term "comprising",
35 features other than that or those prefaced by the term may also be present. Related terms such as "comprise" and "comprises" are to be interpreted in the same manner.

As used herein the term "and/or" means "and" or "or", or both.

As used herein "(s)" following a noun means the plural and/or singular forms of the noun.

BRIEF DESCRIPTION OF THE DRAWINGS

5 Embodiments of the invention are described by way of example with reference to the accompany drawings in which:

 Figure 1a shows a first preferred embodiment of trampoline system, which has a frame, a jumping mat and an enclosure net held above, and surrounding, the jumping mat to form an enclosed jumping area, the frame and jumping mat connected via a number of fiberglass rods extending upwards from the frame to the edge of the mat.
10

 Figure 1b shows a second preferred embodiment of trampoline system, which also has a frame, a jumping mat and an enclosure net held above, and surrounding, the jumping mat to form an enclosed jumping area, the frame and jumping mat connected via a number of springs aligned generally horizontally and extending outwards from the mat to the frame.
15

 Figure 2 shows a first preferred form of aperture in the enclosure net, which allows a user to enter and exit the jumping area, the aperture substantially circular and having a reinforced edge.

 Figure 3a shows a first preferred form of door system for closing an aperture such as the one shown in figure 2, the door system having a door panel located on the inside of the enclosure net, which pivots around the lower edge, and a self-closing mechanism around at least part of the edge of the door biasing the door panel towards a closed position.
20

 Figure 3b shows a variation of the door system of figure 3a, for closing an aperture such as the one shown in figure 2, the door panel pivoting around the lower edge.
25

 Figure 4a shows a second preferred form of door system for closing an aperture such as the one shown in figure 2, the door system having a pair of overlapping doors located one on each side of the aperture, each door having an associated resilient member which acts as a self-closing mechanism to bias the door panel towards a closed position, the door system shown in the closed position.
30

 Figure 4b shows the second preferred form of door system of figure 4a with the doors in the open position, the doors twisted over themselves to form a loop above the top of the aperture.

 Figure 5 shows a third preferred form of door system, the enclosure aperture in this embodiment being triangular or sail-shaped with one straight, sloped edge, the door panel having a triangular shape and overlapping the aperture on the inside of the aperture, with one edge of the door congruent with and fixed to the straight sloped edge of the aperture to form a hinge, an associated resilient door member fixed to the bottom
35

edge of the door which runs generally parallel to, and just above, the plane of the jumping mat.

DETAILED DESCRIPTION OF PREFERRED EMBODIMENTS

5 Figures 1a and 1b show preferred embodiments of a trampoline system 1. As shown in both Figures 1a and 1b, in each embodiment a trampoline has a frame 4, a rebounding mat 5, and a safety enclosure 2 held in position by a number of enclosure support members or poles 6. The mat 5 is held above the ground in tension and substantially horizontal. The enclosure support members 6 support the enclosure 2 so that
10 the enclosure surrounds and extends upwards from the mat 4 to form an enclosed jumping area. In both embodiment the poles 6 are connected to, and extend upwards from, the frame 4. The enclosures are of a type described in US patents 7708672 and 7854687 which are hereby incorporated by reference.

 In the embodiment shown in Figure 1a, the mat 5 is held in position relative to the
15 frame by a number of flexible rods running from the frame to the edge of the trampoline, with the frame 5 located substantially below the mat 5. Where it would be applicable to do so in this specification, 'frame' should be read as being inclusive of the flexible rods. The trampoline is of a type described in US patents 6319174 and 8105211 which are hereby incorporated by reference.

20 In the embodiment shown in Figure 1b, a portion of the frame 4 is generally in the same horizontal plane as the mat 5 and surrounds the perimeter of the mat 5, with a gap between the frame and the mat in which springs 3 extend between the frame 4 and edge of the mat 5. Where it would be applicable to do so in this specification, 'frame' should be read as being inclusive of the springs.

25 The enclosure 2 is, in the preferred embodiment, formed from netting, such as nylon webbing. An opening or aperture 7 is formed in the enclosure 2 to allow ingress or egress from the jumping area.

 Figure 2 shows a first preferred form of aperture 7a. A circular hole 7a is formed in the enclosure 2 by cutting or similar. The aperture is formed so that the lowest point of
30 the hole 7a is just above the surface of the mat. The edge of the aperture 7a is reinforced with a surrounding pocket 8, which contains a fibreglass rod or similar to stabilise the hole shape and to hold the aperture 7a open. The material that forms the surrounding pocket 8 can also be coloured to help a user easily identify the location of the aperture 7a. Alternatively an arch-shaped aperture such as that shown in Figure 3a could be used for
35 example. In the embodiment shown in Figure 3a, the surrounding pocket 8 is arch-shaped, with the two lower ends terminating at the horizontal plane of the mat 5.

 The enclosure has a door system for covering and closing the aperture 7a when the trampoline system is in use. The door system has two main parts: a door panel, and a

self-closing mechanism which biases the door panel into a closed position. When a force is applied to the door to open it or otherwise move it away from a fully closed position, the self-closing mechanism will act on the door to return it to the closed position when the opening force is removed from the door.

5

Bottom Levered Door

In the form shown in Figure 3a the door system has a door 9a which is a single panel. The door 9a has the overall form of a solid arch in the closed position, with the sides flaring or curving outwards away from the side of the arch-shaped aperture (although these could also be straight sided). The sides of the arch rise upwards from the base of the door 9a, which is located at or close to the mat 5, and then transition to a curved or rounded top which arches over the top of the door panel. In the preferred form the base of the door panel 9a is connected either to the mat or to the enclosure, but could also be connected to the frame, or left unconnected. The door 9a is sized and shaped to cover and overlap the circular or arch-shaped opening or aperture 7a and is sized and located so as to overlap around the edge of the opening 7a. It is most preferred that the door 9a is made from the same material as the mat. The door system also has a resilient door member 10a, which is connected around the edge of the door 9a. In the preferred form, the resilient member 10a is a rod, bent or shaped so as to fit around the edge of the arch-shaped door 9a, except for the base of the door 9a. In the preferred form, the two free ends 11a of the resilient member 10a extend around the edge of the door, and flare or curve outwards (following the edge of the door) so that the two ends curve to become parallel or nearly parallel to the horizontal plane of the mat 5. In the preferred form, the resilient door member 10a is formed from a resiliently elastic material such as a pultruded fibreglass rod, so that it will maintain its shape when no force is applied to it, but if bent away from its natural or rest state by the application of an external force, will return to its original shape when the bending force is removed. The resilient door member 10a is, in the preferred form, formed as a straight rod and then bent to connect it to the edge of the door 9a via a single pocket or loop along the edge of the door, or via a number of pockets or loops 12 attached to and spaced around the edge, or close to the edge, of the door 9a. It should be noted that in this context, 'connected' and 'attached' should be taken to mean either removably attached or connected, or permanently attached or connected. As outlined above, the pockets or loops 12 could be a single pocket extending partly or fully around the edge, or close to the edge, of the door, or a number of pockets or loops spaced around the edge of the door. Alternatively, the door member 10a could be initially formed as an arch shape or part arch shape.

When a user wishes to enter or exit the jumping area, they open the door 9a by pushing or pulling it so that it rotates inwards towards the mat 5. This bends the resilient

door member 10a away from the closed position, and spring energy is stored in the resilient door member 10a. The user then enters or exits the jumping area. Depending on where the door is pushed, it will bend or twist down either to the left or to the right. Once door 9a is released, the resilient door member 10a will unbend and release the stored
5 spring energy, and the door will return to the closed position.

A variant of the bottom levered door system of Figure 3a is shown in Figure 3b, which shows the door when open ie pushed down onto the mat. The two ends 11b of the resilient door member 10b extend substantially directly downwards past the base of the door 9a and past the edge of the mat 5. The ends 11b extend directly downwards, and are
10 most preferably connected to the frame 4. However, the ends 11b could be connected to any other substantially rigid part of the trampoline structure. Fitting the two free ends 11b to the frame 4 involves slightly bending the lower portion of the resilient door member 10b so that the two free ends 11b point inwards towards the frame, and the lower part of the main body is bowed outwards away from the mat 5. This adds tension so that as the
15 member 10b attempts to return to its original shape, it will press itself, and the door 9b, outwards against the enclosure 2.

When a user wishes to enter or exit the jumping area, they open the door 9b by pushing or pulling it so that it rotates inwards towards the mat 5 (to the position shown in Figure 3b). This bends the resilient door member 10b away from the closed position, and
20 spring energy is stored in the resilient door member 10b. The user then enters or exits the jumping area. In this variant, the door opens directly towards the mat, without necessarily twisting to the left or right side. Once door is released, the resilient door member 10b will unbend and release the stored spring energy, and the door will return to the closed
25 position.

For both variants, it is most preferred that the door is on the inside of the enclosure wall, and that the door 9a or 9b is sized to overlap the edges of the aperture 7 so that it is held against the enclosure and the edge of the aperture. However, in alternative forms the door could be located on the outside of the enclosure.

30 **Double Door**

In the form shown in Figures 4a and 4b the enclosure 2 and enclosure aperture 7 are as described above. The 'double door' door system has two, or a pair of, overlapping doors, each of which are shown as doors 9c in Figure 4. One of the doors is located generally to the left of the aperture, and one to the right. Each door has generally a 'D'
35 shape when viewed from outside the enclosure, with the right-hand one of the pair reversed, so that the 'D' shape is reversed or backwards when viewed from outside the enclosure. Each of the doors has a curved main body (this is inclusive of a short, straight horizontal section at the top and a longer straight horizontal section at the bottom) and a

sloping straight back to the 'D' shape, with the bottom corner further away from the aperture than the top corner of the back of the 'D'. The short horizontal section at the top is generally aligned horizontally and tangential to the circular door aperture. The doors are sewn to the enclosure along the sloping part of the 'D' and for a small distance at the top -
5 generally to around the point at which the tangential line of the top of the door would contact the circular aperture. The main body of each door is formed from the same netting material as the enclosure. Each door has a resilient door member 10c associated with it. The resilient door member 10c is similar to the member 10a described above. Each resilient door member 10c is fixed to edge of its associated door with, preferably, a
10 number of webbing loops 13 around the curved section of the 'D' (preferably including the short horizontal section at the top and the longer section at the bottom), but could be fitted with a single loop or pocket that extends around, or close to, the perimeter or curved section of the 'D'.

To access the trampoline a user puts his or her hand or hands under the bottom
15 edge of the doors and lifts. When lifted up the doors 9c twist over themselves and form a small loop above the top of the aperture. This action bends the rods or resilient door members 10c and puts them in tension (adds spring energy). When released the doors flick back down to cover the aperture. In a similar manner to that outlined above for the bottom levered door, when in the closed position, the rods are slightly bent in tension to
20 follow the outside curve of the circular mat , and the spring energy in the rods will hold the doors against the enclosure to maintain the doors in the closed position.

Sloped Hinge

In the embodiment of Figure 5 the enclosure 2 is generally as described above.
25 However, in this embodiment, the enclosure aperture 7d is a triangular or sail-shaped opening in the enclosure, as shown in Figure 5, with one straight, sloped edge 14. The door 9d is a triangular shape and in the preferred embodiment is made from the same material as the mat. As above, the door is larger than the aperture 7d so as to overlap on the inside, with one edge of the door congruent with the straight sloped edge of the
30 aperture described above. The door 9d is fixed to the enclosure along the congruent edge to form a hinge. A rod or resilient door member 10d is fixed to the bottom edge of the door, which is generally parallel to, and just above, the plane of the mat, with the resilient door member 10d extending all the way along the lower edge of the door and slightly beyond the corner of the door where the bottom edge of the door meets the hinge edge.
35 The rod is fixed to the bottom edge of the door by at least one and preferably a number of loops or pockets along or close to the bottom edge of the door. The extending end of the rod is preferably held in place on the trampoline by similar mechanism. A user opens the door towards the inside of the trampoline by pushing on the door to pivot the door around

the hinge. This adds spring energy to the rod along the bottom edge, and when released, the door will therefore return to the closed position. In the preferred embodiment, the door member 10d is a straight rod. In the most preferred embodiment, the edge of the trampoline enclosure is slightly curved, as the mat is circular. Therefore when the straight rod 10d is held in position against the edge of the mat by the loops or pocket on the bottom of the door and along the edge of the enclosure, the rod 10d will be slightly bent and therefore in tension, helping to hold the door closed. However, it should be noted that this configuration is not a required configuration.

10 **Door Lock**

Optionally the door or doors can be fitted with a door lock. In the preferred embodiment the door lock consists of a plastic ball that is preferably attached to the enclosure, and most preferably to the perimeter of the aperture around the reinforcement which is located around the edge of the aperture, via a short length of line or similar. The plastic ball corresponds to a slot in the door. To hold or 'lock' the door closed, the plastic ball is pushed through the slot. When the door is pulled or pushed, the line attaching the ball to the enclosure is pulled to one end of the slot. At the same time, the slot is pulled closed by the tension generated. This prevents the ball from being released, and thus the door is held closed.

20

The foregoing description of the invention includes preferred forms thereof. Modifications may be made thereto without departing from the scope of the invention, as defined in the accompanying claims.

CLAIMS:

1. A trampoline system comprising:
a trampoline, having
5 a flexible rebounding mat,
a frame, adapted to hold the flexible rebounding mat in tension in a substantially horizontal plane above the frame,
an enclosure formed from a barrier of a flexible material, having a lower peripheral part coupled directly or indirectly to the mat,
10 a plurality of generally upright enclosure support members connected to the frame and extending upwards from the frame around the mat,
the enclosure connected to the support members so as to surround the mat above the mat and extend around the mat, the enclosure having, or being connected to the mat so as to form, an opening for ingress and egress,
15 the trampoline system further having a door system comprising:
at least one door panel, sized and shaped to at least partly cover or close the opening, and,
at least one resilient member associated with and connecting between the at least one door panel and the trampoline, the at least one door panel movable between an open
20 position allowing ingress and egress, and a closed position where the door panel at least partly covers or closes the opening, the resilient member acting to bias the door panel to the closed position, and to return the door panel to the closed position from the open position.
- 25 2. A trampoline system as claimed in claim 1 wherein the resilient door member comprises a pultruded fibreglass rod.
3. A trampoline system as claimed in claim 1 or 2 wherein the resilient door member is a rod, attached around an edge of the door panel.
- 30 4. A trampoline system as claimed in claim 2 or claim 3 wherein the two ends of the rod curve outwards to become substantially parallel to the horizontal plane of the rebounding mat, the ends connected to either the mat or the enclosure or both.
- 35 5. A trampoline system as claimed in claim 2 or claim 3 wherein the two ends of the rod extend downwards past the base of the door panel and past the edge of the mat to connect to the frame.

6. A trampoline system as claimed in claim 5 wherein the frame and the rod are adapted so that the two free ends are connected to the frame to point inwards towards the frame, so that the lower part of the main body of the resilient member is bowed outwards away from the mat.

5

7. A trampoline system as claimed in any one of claims 2 to 6 wherein the resilient door member is formed as a straight rod, the door panel having one or more pockets or loops on or close to the edge of the door, the rod bent and located into the one or more pockets or loops so as to run around the edge of the door panel, or close to the edge of the door panel.

10

8. A trampoline system as claimed in any one of claims 1 to 7 wherein the base of the door panel is connected to a component of the trampoline.

15

9. A trampoline system as claimed in claim 8 wherein the base of the door panel is connected to any one, or a combination of, the frame, the mat, or the enclosure.

10. A trampoline system as claimed in any one of claims 1 to 9 wherein the door panel is made from the same material as the mat.

20

11. A trampoline system as claimed in any one of claims 1 to 10 wherein the opening is substantially circular.

12. A trampoline system as claimed in any one of claims 1 to 10 wherein the opening is substantially arch-shaped.

25

13. A trampoline system as claimed in claim 11 or claim 12 wherein the perimeter of the opening is reinforced with a pultruded fibreglass rod.

14. A trampoline system as claimed in claim 1 wherein the door system has a pair of door panels which overlap to cover or close the opening.

30

15. A trampoline system as claimed in claim 14 wherein one of the door panels is located generally to the left of the aperture, and one to the right, each door having generally a 'D' shape and a curved main body, and a sloping straight back to the 'D' shape, with the bottom corner further away from the aperture than the top corner of the back of the 'D', the right-hand one of the pair reversed, the doors sewn to the enclosure along the sloping part of the 'D' and at least partly along the top of the main body.

35

16. A trampoline system as claimed in claim 14 or claim 15 wherein the main body of each door panel is formed from the same netting material as the enclosure.
- 5 17. A trampoline system as claimed in any one of claims 14 to 16 wherein each door panel has an associated resilient door member, fixed to edge of the door panel with at least one webbing loop or pocket that extends around the curved section.
- 10 18. A trampoline system as claimed in claim 17 wherein the resilient member comprises a pultruded fibreglass rod.
19. A trampoline system as claimed in claim 18 wherein the lower part of the end of the rod extends past the lower corner of the door panel along the perimeter of the mat.
- 15 20. A trampoline system as claimed in any one of claims 14 to 19 wherein the opening is substantially circular.
21. A trampoline system as claimed in any one of claims 14 to 20 wherein the opening is substantially arch-shaped.
- 20 22. A trampoline system as claimed in claim 20 or claim 21 wherein the perimeter of the opening is reinforced with a pultruded fibreglass rod.
23. A trampoline system as claimed in claim 1 wherein the door panel of the door system has a generally triangular shape with one upright edge of the door panel fixed to the enclosure to form a hinge, and the at least one resilient member is a rod fixed to the bottom edge of the door panel so as to run generally parallel to, and just above, the plane of the mat and extend along the lower edge of the door panel.
- 25 24. A trampoline system as claimed in claim 23 wherein the rod is a straight rod.
25. A trampoline system as claimed in claim 23 or 24 wherein the rod is held in position against the edge of the mat by one or more loops or pockets on the bottom of the door.
- 30 26. A trampoline system as claimed in any one of claims 23 to 25 wherein the rod extends beyond that corner of the door panel where the bottom edge meets the hinge
- 35

edge, and is held in place on the trampoline by one or more loops or pockets connected to the trampoline.

27. A trampoline system as claimed in any one of claims 23 to 26 wherein the enclosure aperture is a triangular or sail-shaped opening in the enclosure, with one straight, sloped edge, one edge of the door congruent with the straight sloped edge of the aperture.

28. A trampoline system as claimed in any one of claims 23 to 27 wherein the door panel is made from the same material as the mat.

29. A trampoline system as claimed in any one of claims 1 to 28 wherein the door is fitted with a door lock comprising a ball and a slot in the door, the ball pushable through the slot when the door is on the closed position to hold the door closed.

30. A door system for a trampoline enclosure having an opening for ingress and egress, the door system comprising:

at least one door panel, at least part of the periphery of the door panel forming an attachment edge adapted for attachment to a trampoline,

a resilient spring member attached around at least part of the periphery of the door panel, the resilient door member formed from a resiliently elastic material such as a pultruded fibreglass rod, at least one end of the rod extending past the edge of the door panel.

31. A door system for a trampoline enclosure as claimed in claim 30 wherein the attachment edge forms a base to the door panel, and the resilient rod is connected to the door panel around the remainder of the periphery, the two ends of the rod extending past the base edge for attachment to a trampoline.

32. A door system for a trampoline enclosure as claimed in claim 31 wherein the door panel has one or more pockets or loops around the remainder of the periphery of the door panel, the rod bent or otherwise located into the one or more pockets or loops.

33. A door system for a trampoline enclosure as claimed in any one of claims 30 to 32 wherein the door panel has an arch shape.

34. A door system for a trampoline enclosure as claimed in claim 30 wherein the door panel has a general 'D' shape with a curved main body and a sloping straight back, the

sloping back forming the attachment edge, the resilient spring member attached around the periphery of the curved main body.

35. A door system for a trampoline enclosure as claimed in claim 34 wherein the resilient door member is connected to the edge of the door panel by at least one webbing loop or pocket around the curved section.

36. A door system for a trampoline enclosure as claimed in claim 30 wherein the door panel has a generally triangular shape with one edge adapted for attachment to the enclosure to form a hinge, and the at least one resilient member is a straight rod fixed to an adjacent edge and extending beyond the corner where the adjacent edge and the hinge edge meet.

37. A door system as claimed in claim 36 wherein the rod is fixed to the adjacent edge by at least one loop or pocket on one edge of the door.

38. A door system as claimed in claim 36 or claim 37 wherein the rod extends beyond that corner of the door panel where the bottom edge meets the hinge edge, and is held in place on the trampoline by at least one pocket or loop connected to the trampoline.

39. A door system as claimed in any one of claims 36 to 38 wherein the enclosure aperture is a triangular or sail-shaped opening in the enclosure, with one straight, sloped edge, one edge of the door congruent with the straight sloped edge of the aperture.

40. A trampoline enclosure system for a trampoline comprising:
an enclosure formed from a barrier of a flexible material for in use surrounding a trampoline jumping surface and extending upwards around the jumping surface, the enclosure having an opening for ingress and egress,
a door system having at least one door panel, sized and shaped to at least partly cover or close the opening, and at least one resilient member associated with the at least one door panel, the at least one door panel movable between an open position allowing ingress and egress, and a closed position where the door panel at least partly covers or closes the opening, the resilient member acting to bias the door panel to the closed position, and to return the door panel to the closed position from the open position.

41. A trampoline enclosure system as claimed in claim 40 wherein the resilient door member is formed from a pultruded fibreglass rod.

42. A trampoline enclosure system as claimed in claim 40 or 41 wherein the resilient member is a rod, bent or shaped and in use connected to the trampoline so that the two ends of the rod extend downwards past the edge of the door panel, the rod attached around the edge of the door panel, except for the base of the door panel.

5

43. A trampoline enclosure system as claimed in claim 41 or claim 42 wherein the resilient door member is formed as a straight rod, the door panel having at least one pocket or loop on or close to the edge of the door, the rod bent and located into the at least one pocket or loop so as to run around the edge of the door panel, or close to the edge of the door panel.

10

44. A trampoline enclosure system as claimed in any one of claims 40 to 43 wherein the opening is substantially circular.

15

45. A trampoline enclosure system as claimed in any one of claims 40 to 43 wherein the opening is substantially arch-shaped.

46. A trampoline enclosure system as claimed in claim 44 or claim 45 wherein the perimeter of the opening is reinforced with a pultruded fibreglass rod.

20

47. A trampoline enclosure system as claimed in claim 40 wherein the door system has a pair of door panels which overlap to cover or close the opening.

48. A trampoline enclosure system as claimed in claim 47 wherein one of the door panels is located generally to the left of the aperture, and one to the right, each door having generally a 'D' shape and a curved main body, and a sloping straight back to the 'D' shape, with the bottom corner further away from the aperture than the top corner of the back of the 'D', the right-hand one of the pair reversed, the doors sewn to the enclosure along the sloping part of the 'D' and at least partly along the top of the main body.

30

49. A trampoline enclosure system as claimed in claim 40 or claim 41 wherein the door panels and the enclosure are formed from the same material.

50. A trampoline enclosure system as claimed in any one of claims 47 to 49 wherein each door panel has an associated resilient door member, attached to the edge of the door panel by at least one webbing loop or pocket on or extending around the curved section.

35

51. A trampoline enclosure system as claimed in claim 50 wherein the resilient member is formed from a resiliently elastic material such as a pultruded fibreglass rod.
52. A trampoline enclosure system as claimed in claim 51 wherein the lower part of the end of the rod extends past the lower corner of the door panel.
53. A trampoline enclosure system as claimed in any one of claims 47 to 52 wherein the opening is substantially circular.
54. A trampoline enclosure system as claimed in any one of claims 47 to 52 wherein the opening is substantially arch-shaped.
55. A trampoline enclosure system as claimed in claim 53 or claim 54 wherein the perimeter of the opening is reinforced with a pultruded fibreglass rod.
56. A trampoline enclosure system as claimed in claim 40 wherein the door panel of the door system has a generally triangular shape with one upright edge of the door panel fixed to the enclosure to form a hinge, and the at least one resilient member is a rod fixed to the bottom edge of the door panel so as to run generally parallel to, and just above, the plane of the jumping surface in use and extend along the lower edge of the door panel.
57. A trampoline enclosure system as claimed in claim 56 wherein the rod is a straight rod.
58. A trampoline enclosure system as claimed in claim 56 or claim 57 wherein the rod extends beyond that corner of the door panel where the bottom edge meets the hinge edge.
59. A trampoline enclosure system as claimed in any one of claims 56 to 58 wherein the enclosure aperture is a triangular or sail-shaped opening in the enclosure, with one straight, sloped edge, one edge of the door congruent with the straight sloped edge of the aperture to form the hinge.
60. A trampoline enclosure system as claimed in any one of claims 40 to 59 wherein the door is fitted with a door lock comprising a ball and a slot in the door, the ball pushable through the slot when the door is on the closed position, to hold the door closed.

1/8

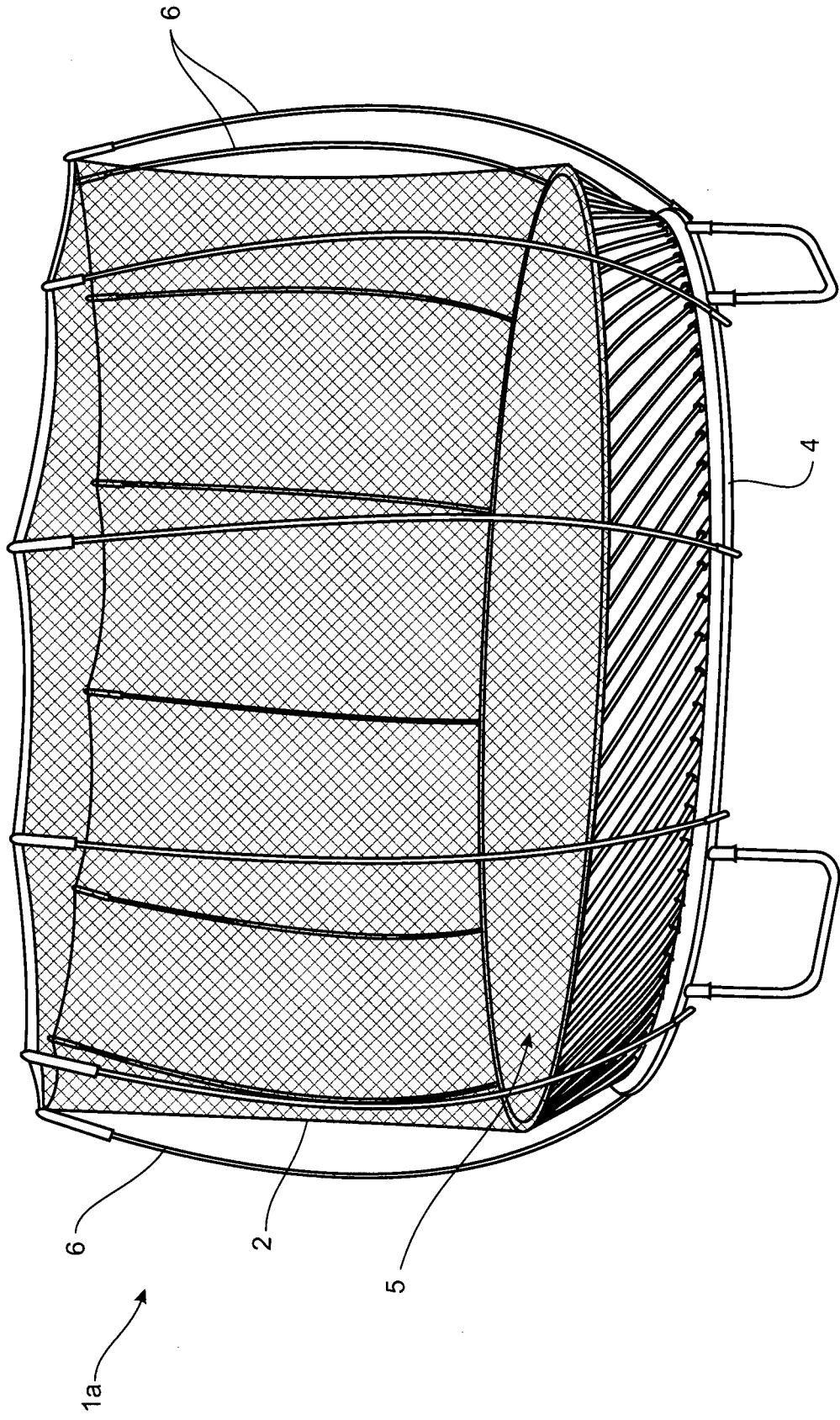

FIGURE 1A

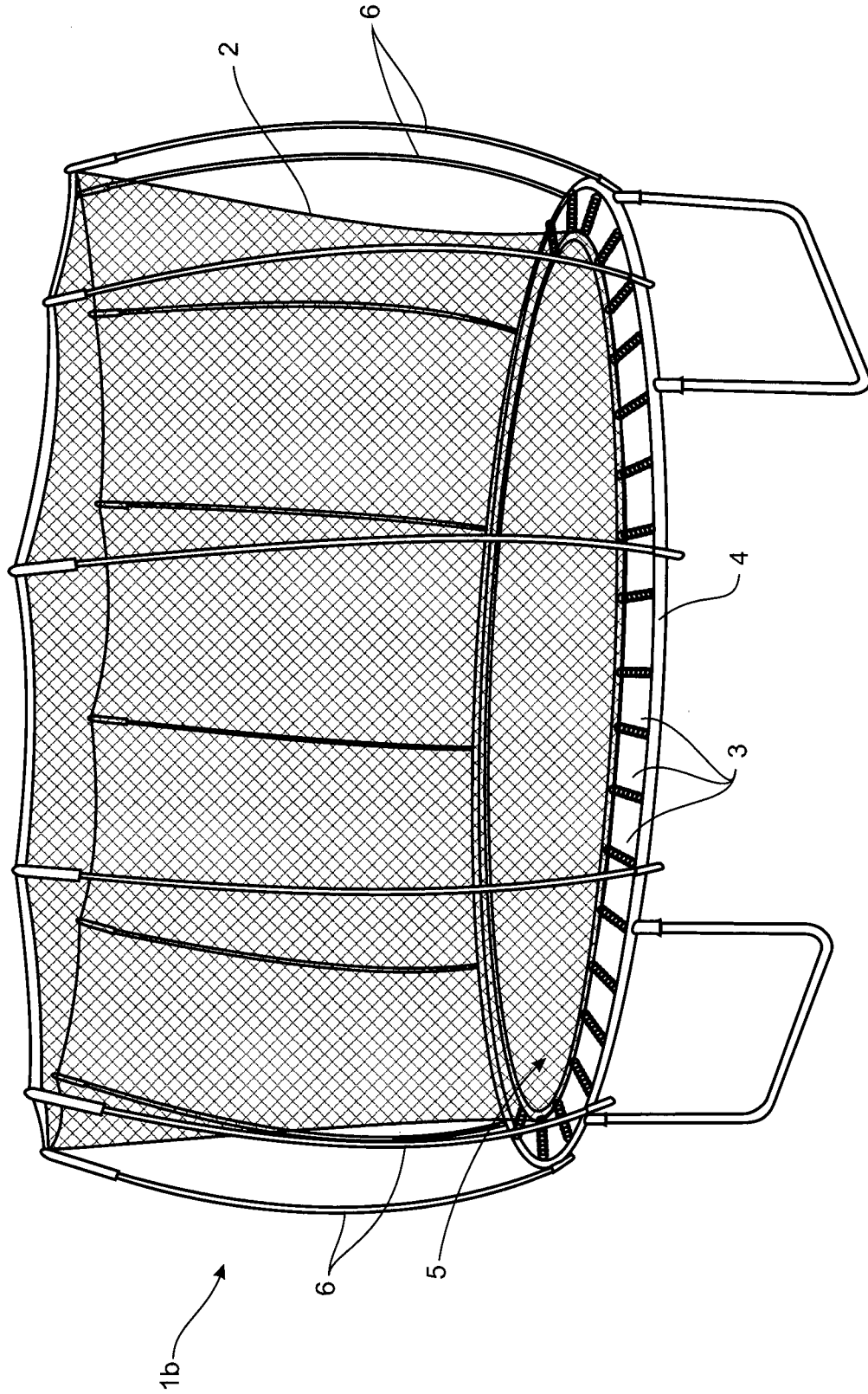

FIGURE 1B

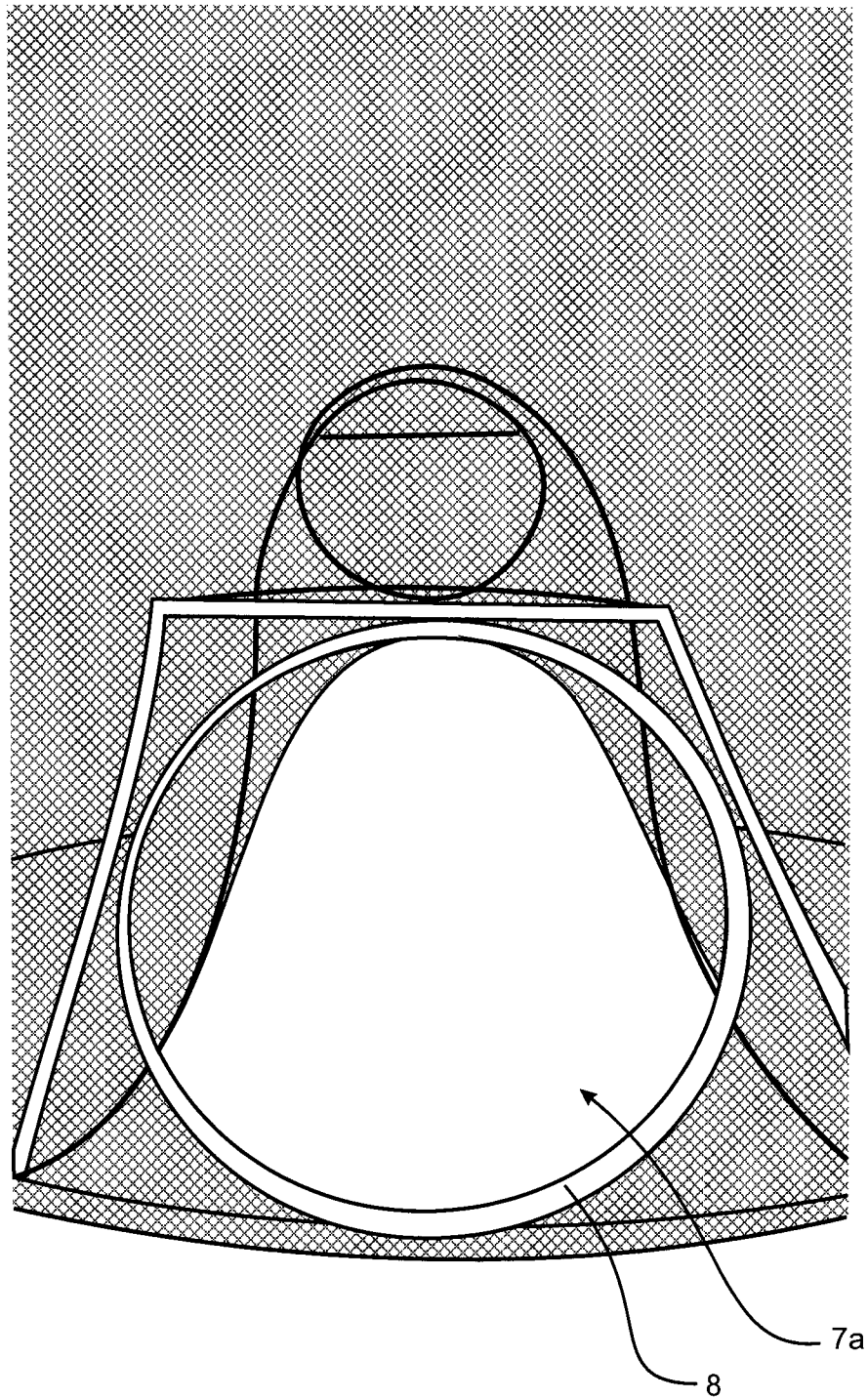

FIGURE 2

4/8

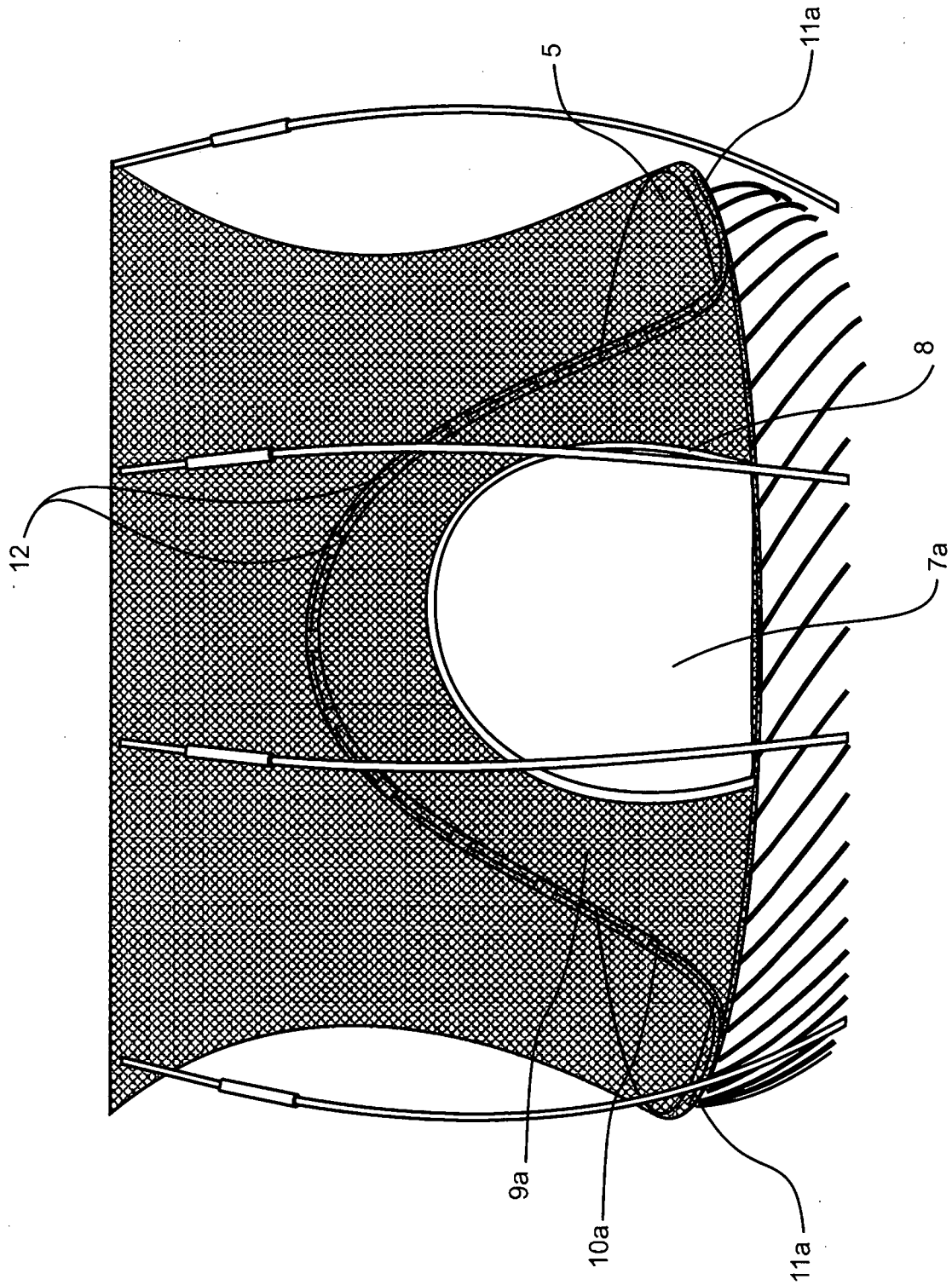

FIGURE 3A

5/8

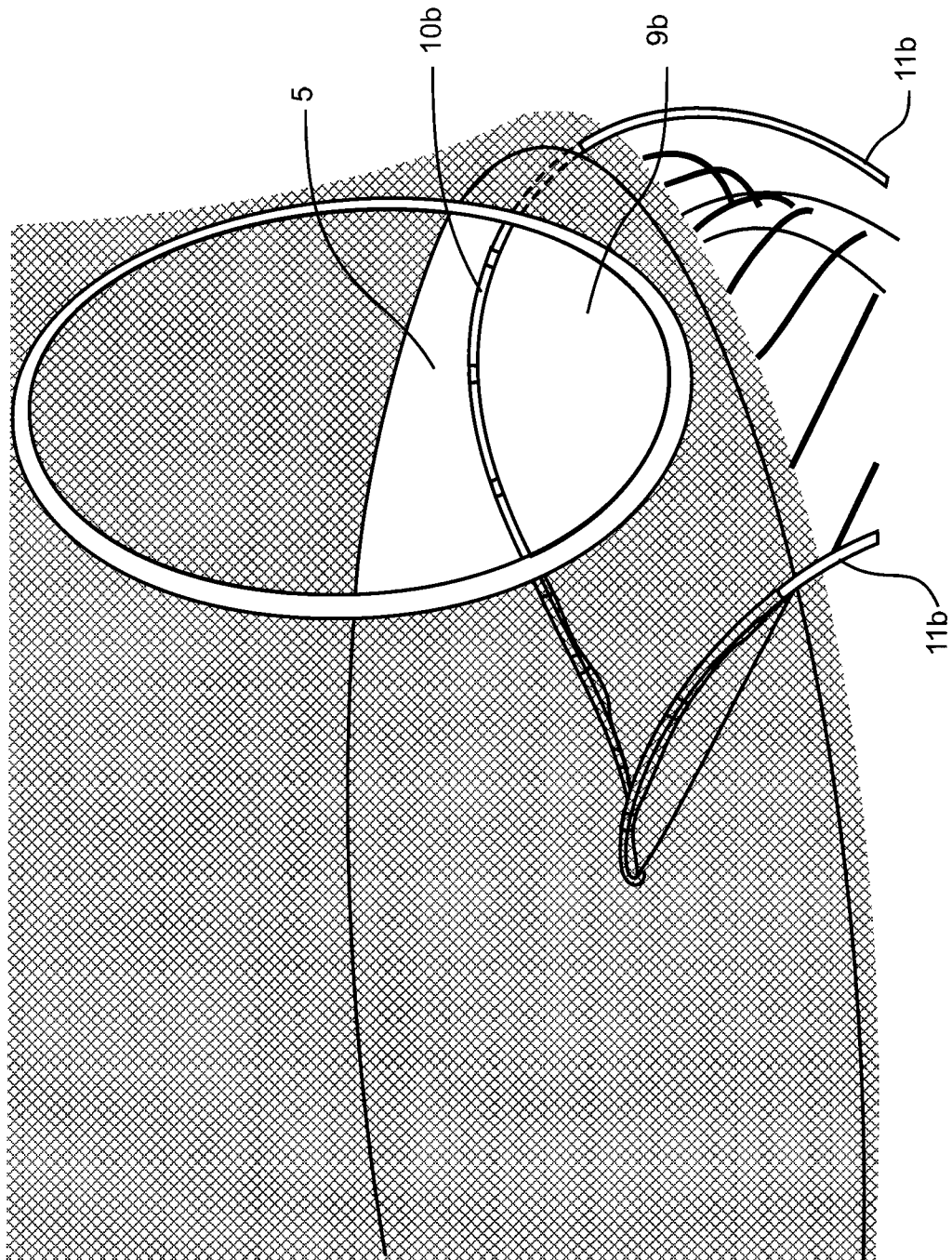

FIGURE 3B

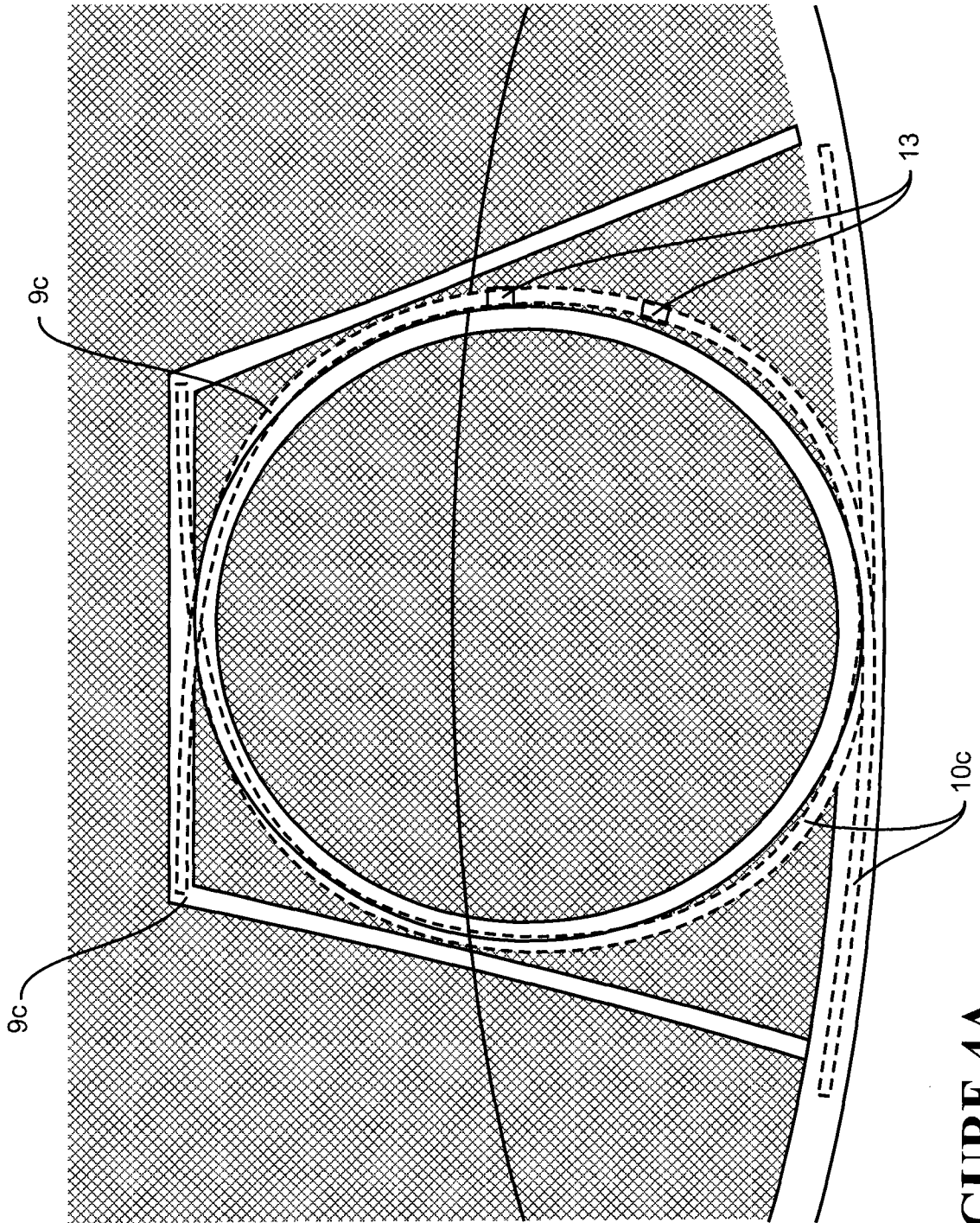

FIGURE 4A

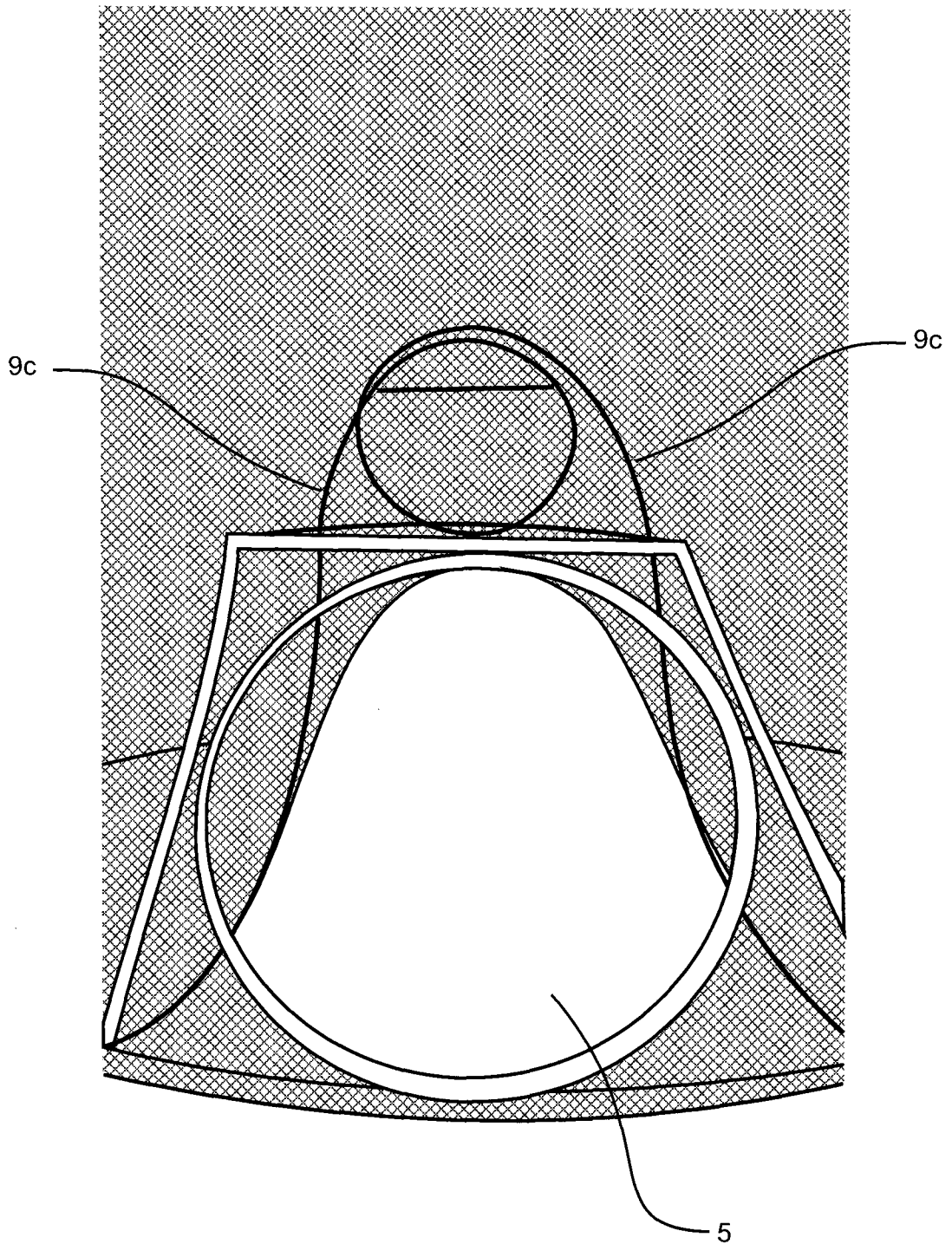

FIGURE 4B

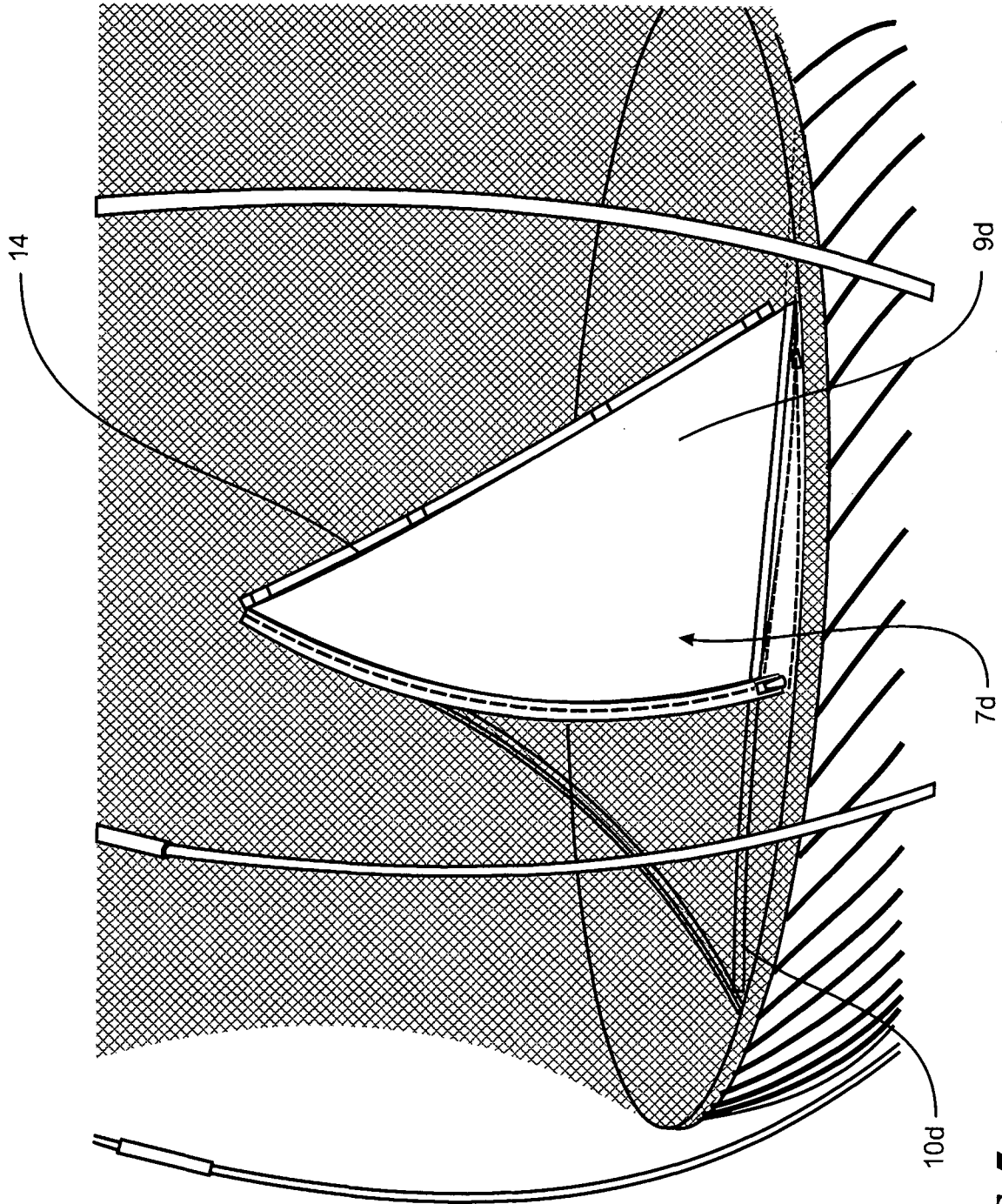

FIGURE 5

INTERNATIONAL SEARCH REPORT

International application No.

PCT/NZ2012/000071

A. CLASSIFICATION OF SUBJECT MATTER

A63B 5/11 (2006.01)

According to International Patent Classification (IPC) or to both national classification and IPC

B. FIELDS SEARCHED

Minimum documentation searched (classification system followed by classification symbols)

Documentation searched other than minimum documentation to the extent that such documents are included in the fields searched

Electronic data base consulted during the international search (name of data base and, where practicable, search terms used)

WPI, EPODOC: IC/EC A63B 5/11 (keywords: enclosure, inclosure, enclosed, inclosed, net, mesh, web, screen, surround, cage, covered, door, entrance, exit, ingress, egress, aperture, opening, slit, hole, gate, automatic, self-close, spring, resilient, bias, tension, attach, flexible and similar words)

C. DOCUMENTS CONSIDERED TO BE RELEVANT

Category*	Citation of document, with indication, where appropriate, of the relevant passages	Relevant to claim No.
	Documents are listed in the continuation of Box C	

 Further documents are listed in the continuation of Box C See patent family annex

* Special categories of cited documents:		
"A" document defining the general state of the art which is not considered to be of particular relevance	"T" later document published after the international filing date or priority date and not in conflict with the application but cited to understand the principle or theory underlying the invention	
"E" earlier application or patent but published on or after the international filing date	"X" document of particular relevance; the claimed invention cannot be considered novel or cannot be considered to involve an inventive step when the document is taken alone	
"L" document which may throw doubts on priority claim(s) or which is cited to establish the publication date of another citation or other special reason (as specified)	"Y" document of particular relevance; the claimed invention cannot be considered to involve an inventive step when the document is combined with one or more other such documents, such combination being obvious to a person skilled in the art	
"O" document referring to an oral disclosure, use, exhibition or other means	"&" document member of the same patent family	
"P" document published prior to the international filing date but later than the priority date claimed		

Date of the actual completion of the international search
10 September 2012Date of mailing of the international search report
14 September 2012

Name and mailing address of the ISA/AU

AUSTRALIAN PATENT OFFICE
PO BOX 200, WODEN ACT 2606, AUSTRALIA
Email address: pct@ipaustrialia.gov.au
Facsimile No.: +61 2 6283 7999

Authorised officer

Lejla Abaz
AUSTRALIAN PATENT OFFICE
(ISO 9001 Quality Certified Service)
Telephone No. 0262256137

INTERNATIONAL SEARCH REPORT C (Continuation). DOCUMENTS CONSIDERED TO BE RELEVANT		International application No. PCT/NZ2012/000071
Category*	Citation of document, with indication, where appropriate, of the relevant passages	Relevant to claim No.
A	US 2008/0269019 A1 (LOVLEY, II) 30 October 2008 Whole document, in particular Abstract, Figures 1-7, paragraphs [0021]-[0028];	1-60
A	US 2005/0079954 A1 (WANG et al.) 14 April 2005 Whole document, in particular Abstract, Figures 3-5;	1-60

INTERNATIONAL SEARCH REPORT

Information on patent family members

International application No.

PCT/NZ2012/000071

This Annex lists known patent family members relating to the patent documents cited in the above-mentioned international search report. The Australian Patent Office is in no way liable for these particulars which are merely given for the purpose of information.

Patent Document/s Cited in Search Report		Patent Family Member/s	
Publication Number	Publication Date	Publication Number	Publication Date
US 2008/0269019 A1	30 Oct 2008	US 2008269019 A1	30 Oct 2008
		US 7883446 B2	08 Feb 2011
US 2005/0079954 A1	14 Apr 2005	US 2005079954 A1	14 Apr 2005

End of Annex

Due to data integration issues this family listing may not include 10 digit Australian applications filed since May 2001.

Form PCT/ISA/210 (Family Annex)(July 2009)