



- (51) International Patent Classification:
F02C 3/14 (2006.01) F02K 3/00 (2006.01)
F02C 1/00 (2006.01) F23R 3/06 (2006.01)
- (21) International Application Number:
PCT/US2013/043543
- (22) International Filing Date:
31 May 2013 (31.05.2013)
- (25) Filing Language: English
- (26) Publication Language: English
- (30) Priority Data:
13/490,760 7 June 2012 (07.06.2012) US
- (71) Applicant: UNITED TECHNOLOGIES CORPORATION [US/US]; One Financial Plaza, Hartford, CT 06101 (US).
- (72) Inventors: CUNHA, Frank, J.; 5 Bruce Lane, Avon, CT 06001 (US). ERBAS-SEN, Nurhak; 387 Dennison Ridge Drive, Manchester, CT 06040 (US).
- (74) Agents: MCINTIRE, John, C. et al.; Kinney & Lange, P.A., The Kinney & Lange Building, 312 South Third Street, Minneapolis, MN 55415 (US).

- (81) Designated States (unless otherwise indicated, for every kind of national protection available): AE, AG, AL, AM, AO, AT, AU, AZ, BA, BB, BG, BH, BN, BR, BW, BY, BZ, CA, CH, CL, CN, CO, CR, CU, CZ, DE, DK, DM, DO, DZ, EC, EE, EG, ES, FI, GB, GD, GE, GH, GM, GT, HN, HR, HU, ID, IL, IN, IS, JP, KE, KG, KN, KP, KR, KZ, LA, LC, LK, LR, LS, LT, LU, LY, MA, MD, ME, MG, MK, MN, MW, MX, MY, MZ, NA, NG, NI, NO, NZ, OM, PA, PE, PG, PH, PL, PT, QA, RO, RS, RU, RW, SC, SD, SE, SG, SK, SL, SM, ST, SV, SY, TH, TJ, TM, TN, TR, TT, TZ, UA, UG, US, UZ, VC, VN, ZA, ZM, ZW.
- (84) Designated States (unless otherwise indicated, for every kind of regional protection available): ARIPO (BW, GH, GM, KE, LR, LS, MW, MZ, NA, RW, SD, SL, SZ, TZ, UG, ZM, ZW), Eurasian (AM, AZ, BY, KG, KZ, RU, TJ, TM), European (AL, AT, BE, BG, CH, CY, CZ, DE, DK, EE, ES, FI, FR, GB, GR, HR, HU, IE, IS, IT, LT, LU, LV, MC, MK, MT, NL, NO, PL, PT, RO, RS, SE, SI, SK, SM, TR), OAPI (BF, BJ, CF, CG, CI, CM, GA, GN, GQ, GW, KM, ML, MR, NE, SN, TD, TG).

Published:
— without international search report and to be republished upon receipt of that report (Rule 48.2(g))

(54) Title: COMBUSTOR LINER WITH DECREASED LINER COOLING

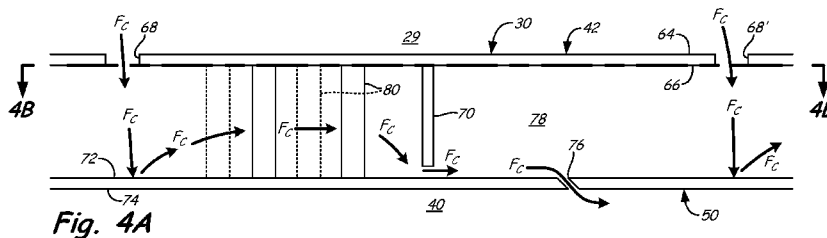

(57) Abstract: A shell for a combustor liner includes a cold side, a hot side, a row of cooling holes and a jet wall. The jet wall projects from the hot side for creating a wall shear jet of increased velocity cooling flow in a tangential direction away from the row of cooling holes and along an adjacent heat shield cold side wall.



COMBUSTOR LINER WITH DECREASED LINER COOLING

BACKGROUND

The present invention relates to a turbine engine. In particular, the invention relates to liner cooling for combustor for a gas turbine engine.

A turbine engine ignites compressed air and fuel in a combustion chamber, or combustor, to create a flow of hot combustion gases to drive multiple stages of turbine blades. The turbine blades extract energy from the flow of hot combustion gases to drive a rotor. The turbine rotor drives a fan to provide thrust and drives compressor to provide a flow of compressed air. Vanes interspersed between the multiple stages of turbine blades align the flow of hot combustion gases for an efficient attack angle on the turbine blades.

There is a desire to improve the fuel efficiency, or thrust specific fuel consumption (TSFC), of turbine engines. TSFC is a measure of the fuel consumed per unit of thrust produced by an engine. Fuel efficiency may be improved by increasing the combustion temperature and pressure under which the engine operates. However, under such conditions, undesirable combustion byproducts (e.g. nitrogen oxides (NO_x)) may form at an increased rate. In addition, the higher temperatures may require additional cooling air to protect engine components. A source of cooling air is typically taken from a flow of compressed air produced upstream of the turbine stages. Energy expended on compressing air used for cooling engine components is not available to produce thrust. Improvements in the efficient use of compressed air for cooling engine components can improve the overall efficiency of the turbine engine.

SUMMARY

An embodiment of the present invention is a shell for a combustor liner including a cold side, a hot side, a row of cooling holes and a jet wall. The jet wall projects from the hot side for creating a wall shear jet of increased velocity cooling flow in a tangential direction away from the row of cooling holes and along an adjacent heat shield cold side wall.

BRIEF DESCRIPTION OF THE DRAWINGS

FIG. 1 is a sectional view of a gas turbine engine embodying the present invention.

FIG. 2 is an enlarged sectional view of the combustor of the gas turbine engine shown in FIG. 1.

FIG. 3 is a top view of a portion of the combustor shown in FIG. 2.

FIGS. 4A and 4B are further enlarged side and top sectional views, respectively, of a combustor liner of the combustor of FIG. 2.

FIGS. 5A and 5B are further enlarged side and top sectional views, respectively, of another embodiment of a combustor liner of the combustor of FIG. 2.

FIGS. 6A and 6B are further enlarged side and top sectional views, respectively, of another embodiment of a combustor liner of the combustor of FIG. 2.

FIGS. 7A and 7B are further enlarged side and top sectional views, respectively, of another embodiment of a combustor liner of the combustor of FIG. 2.

FIGS. 8A and 8B are further enlarged side and top sectional views, respectively, of another embodiment of a combustor liner of the combustor of FIG. 2.

DETAILED DESCRIPTION

The present invention improves the efficiency of a gas turbine engine by reducing the cooling air required to cool a combustor. Combustor liners may include any or all of four features: dilution openings in a staggered, overlapping arrangement, a convergent channel within the combustor liner, a jet wall within the combustor liner, and a multi-cornered cooling film slot. Employing dilution openings in a staggered, overlapping arrangement provides full circumferential coverage around a combustor and eliminates high-heat flux areas downstream of the dilution openings, thus reducing combustor liner cooling requirements. A series of projecting walls and wall turbulators, or trip strips, form a convergent channel within the liner to increase cooling flow velocity and improve convective heat transfer. A jet wall also increases the velocity of cooling air by creating a wall shear jet across the hot surface of the liner. Finally, a multi-cornered film cooling slot forms a film cooling layer on the inside surface of the liner that spreads out to uniformly cover the surface. Together, the staggered dilution openings, convergent channel, jet wall, and multi-cornered film cooling slot significantly reduce the cooling air requirements of a combustor and improve the fuel efficiency of a gas turbine engine.

FIG. 1 is a representative illustration of a gas turbine engine including a combustor embodying the present invention. The view in FIG. 1 is a longitudinal sectional view along an engine center line. FIG. 1 shows gas turbine engine 10 including fan 12, compressor 14, combustor 16, turbine 18, high-pressure rotor 20, low-pressure rotor 22, outer casing 24, and inner casing 25. Turbine 18 includes rotor stages 26 and stator stages 28.

As illustrated in FIG. 1, fan 12 is positioned along engine center line C_L at one end of gas turbine engine 10. Compressor 14 is adjacent fan 12 along engine center line C_L , followed by combustor 16. Combustor 16 is an annular structure that extends circumferentially around engine center line C_L . Turbine 18 is located adjacent
5 combustor 16, opposite compressor 14. High-pressure rotor 20 and low-pressure rotor 22 are mounted for rotation about engine center line C_L . High-pressure rotor 20 connects a high-pressure section of turbine 18 to compressor 14. Low-pressure rotor 22 connects a low-pressure section of turbine 18 to fan 12. Rotor blades 26 and stator vanes 28 are arranged throughout turbine 18 in alternating rows. Rotor blades 26 connect to high-
10 pressure rotor 20 and low-pressure rotor 22. Outer casing 24 surrounds turbine engine 10 providing structural support for compressor 14, and turbine 18, as well as containment for a flow of cooling air F_c . Inner casing 25 is generally radially inward from combustor 16 providing structural support for combustor 16 as well as containment for the flow of cooling air F_c .

15 In operation, air flow F enters compressor 14 through fan 12. Air flow F is compressed by the rotation of compressor 14 driven by high-pressure rotor 20 producing a flow of cooling air F_c . Cooling air F_c flows between combustor 16 and each of outer case 24 and inner case 25. A portion of cooling air F_c enters combustor 16, with the remaining portion of cooling air F_c employed farther downstream for cooling other
20 components exposed to high-temperature combustion gases, such as rotor blades 26 and stator vanes 28. Compressed air and fuel are mixed and ignited in combustor 16 to produce high-temperature, high-pressure combustion gases F_p . Combustion gases F_p exit combustor 16 into turbine section 18. Stator vanes 28 properly align the flow of combustion gases F_p for an efficient attack angle on subsequent rotor blades 26. The
25 flow of combustion gases F_p past rotor blades 26 drives rotation of both high-pressure rotor 20 and low-pressure rotor 22. High-pressure rotor 20 drives a high-pressure portion of compressor 14, as noted above, and low-pressure rotor 22 drives fan 12 to produce thrust F_s from gas turbine engine 10. Although embodiments of the present invention are illustrated for a turbofan gas turbine engine for aviation use, it is
30 understood that the present invention applies to other aviation gas turbine engines and to industrial gas turbine engines as well.

FIG. 2 is an enlarged view illustrating details of combustor 16 of gas turbine engine 10 shown in FIG. 1. FIG. 2 illustrates combustor 16, outer case 24, and inner case 25. Outer case 24 and inner case 25 are radially outward and inward,

respectively, from combustor 16, thus creating annular plenum 29 around combustor 16. Combustor 16 is an annular structure that extends circumferentially around engine center line C_L . Combustor 16 includes combustor liner 30, bulkhead 32, bulkhead heat shield 34, fuel nozzle 36, swirler 38, and combustion chamber 40. Combustor liner 30 includes
5 outer shell 42, inner shell, 44, aft inside diameter (ID) heat shield 46, forward ID heat shield 48, aft outside diameter (OD) heat shield 50, forward OD heat shield 52, studs 54, and dilution openings 56. Combustor 16 is an annular structure that extends circumferentially around engine center line C_L , thus combustor liner 30 is arcuate in shape, with an axis coincident with engine center line C_L .

10 Combustion chamber 40 within combustor 16 is bordered radially by combustor liner 30, by bulkhead 32 on the upstream axial end, with a combustion gas opening on the downstream axial end. Swirler 38 connects fuel nozzle 36 to bulkhead 32 through an opening in bulkhead 32. Bulkhead 32 is protected from the hot flow of combustion gases F_p generated within combustion chamber 40 by bulkhead heat shield
15 34. Aft ID heat shield 46 and forward ID heat shield 48 are attached to inner shell 44 to make up the inside diameter portion of combustor liner 30. Similarly, aft OD heat shield 50 and forward OD heat shield 52 are attached to outer shell 42 to make up the outside diameter portion of combustor liner 30. Heat shields 46, 48, 50, 52 are attached to their respective shell 42, 44 by studs 52 projecting from heat shields 46, 48, 50, 52. Dilution
20 openings 56 are openings through combustor liner 30 permitting the flow of cooling air flow from plenum 29 into combustion chamber 40.

In operation, fuel from fuel nozzle 36 mixes with air in swirler 38 and is ignited in combustion chamber 40 to produce the flow of combustion gases F_p for use by turbine 18 as described above in reference to FIG. 1. As the flow of combustion gases
25 F_p passes through combustion chamber 40, a flow of cooling air F_c is injected into combustion chamber 40 from plenum 29 through dilution openings 56 to create dilution jets into the flow of combustion gases F_p . The dilution jets serve to mix and cool the flow of combustion gases F_p to reduce the formation of NOx. The dilution jets in this embodiment reduce combustor cooling requirements, as described below in reference to
30 FIG. 3. Combustor liner 30 is cooled by a flow of cooling air F_c flowing from plenum 29 through combustor liner 30, as will be described in greater detail below in reference to FIGS. 4A, 4B, 5A, 5B, 6A, 6B, 7A, 7B, 8A, and 8B.

FIG. 3 is a top view of a portion of the combustor shown in FIG. 2. Specifically, FIG. 3 shows dilution openings 56 in outer shell 42 of combustor liner 30

where outer shell 42 is protected by aft OD heat shield 50, as shown in FIG. 2. In this view, only dilution openings 56 in outer shell 42 are shown, but it is understood that because dilution openings 56 penetrate combustor liner 30 between plenum 39 and combustion chamber 30, aft outer heat shield 50 also includes dilution openings 56. As shown in FIG. 3, dilution openings 56 open into combustion chamber 40 and include first row of dilution openings 60 and second row of dilution openings 62. Both first row of dilution openings 60 and second row of dilution openings 62 run in the circumferential direction and are parallel to each other. Second row of dilution openings 62 is axially spaced from first row of dilution openings 60 only as far as required to maintain the structural integrity of combustor liner 30. Each dilution opening 62 is disposed in a staggered relationship with two adjacent dilution openings 60 such that each dilution opening 62 at least partially overlaps two adjacent dilution openings 60 in an axial direction. Dilution openings 56 may be substantially rectangular in shape, as illustrated in FIG. 3, or may be of other shapes, so long as they overlap in the axial direction.

In operation, dilution openings 56 direct the flow of cooling air F_c to produce dilution jets within combustion chamber 40 in a staggered, overlapping arrangement that provides full circumferential coverage around the circumference of combustor 16. This coverage eliminates recirculation zones that would otherwise form downstream of the dilution jets, thus eliminating high-heat flux areas that would form in the recirculation zone downstream of the dilution jets. Because the high-heat flux areas are eliminated, there is less need to cool combustor liner 30. In addition, because dilution openings 56 provide full circumferential coverage, mixing of the flow of cooling air F_c into the flow of combustion gases F_p is improved, decreasing temperatures within the flow of combustion gases F_p faster, resulting in decreased NO_x formation.

Another feature for improving the efficiency of a gas turbine engine by reducing the cooling air required to cool a combustor is shown in FIGS. 4A and 4B. FIGS. 4A and 4B are further enlarged side and top sectional views, respectively, of combustor liner 30 of combustor 16 of FIG. 2. FIG. 4A shows combustor liner 30 separating plenum 29 and combustion chamber 40. Combustor liner 30 includes outer shell 42 and aft OD heat shield 50. Outer shell 42 includes shell cold side 64, shell hot side 66, row of impingement cooling holes 68, and jet wall 70. Aft OD heat shield 50 includes shield cold side 72, shield hot side 74, and row of film cooling holes 76. Together, outer shell 42 and aft OD heat shield 50 define cooling air passageway 78

between shell hot side 66 and shield cold side 72. This embodiment also optionally includes pedestal array 80.

Considering FIGS. 4A and 4B together, shell cold side 64 faces plenum 29 while shell hot side faces away from plenum 29, toward shield cold side 72 and combustion chamber 40. Shield hot side 74 faces combustion chamber 40 while shield cold side 72 faces away from combustion chamber 40, toward shell hot side 66 and plenum 29. Row of impingement cooling holes 68 runs in a circumferential direction and allows the flow of cooling air F_c to flow from shell cold side 64 to shell hot side 66. Jet wall 70 runs in a circumferential direction, transverse to the flow of cooling air F_c within cooling air passageway 78. Jet wall 70 projects from shell hot side 66 nearly to shield cold side 72 such that there is a gap between jet wall 70 and aft OD heat shield 50. Row of film cooling holes 76 runs in a circumferential direction and allows the flow of cooling air F_c to flow from shield cold side 72 to shield hot side 74. Row of film cooling holes 76 are slanted in a downstream direction to aid in the formation of a cooling film along shield hot side 74. Pedestals of pedestal array 80 extend across cooling air passage way 78 in a radial direction between shell hot side 66 and shield cold side 72.

In operation, the flow of cooling air F_c flows into cooling air passageway 78 through row of impingement holes 68. The flow of cooling air F_c impinges upon shield cold side 72, absorbing heat and cooling aft OD heat shield 50. The flow of cooling air F_c then optionally flows through pedestal array 80 where the pedestals increase the turbulence and convective heat transfer of the flow of cooling air F_c , enhancing further heat transfer from aft OD heat shield 50. The flow of cooling air F_c then flows through the gap between jet wall 70 and shield cold side 72. The large reduction in the area available for the flow of cooling air F_c presented by jet wall 70 results in a large increase in the velocity of the flow of cooling air F_c issuing from jet wall 70 and along shield cold side 72 in the tangential or shear direction. The resulting “jet” of cooling air, also known as a wall shear jet, greatly increases the convective heat transfer between the flow of cooling air F_c and aft OD heat shield 50. As the flow of cooling air F_c flows along shield cold side 72 and picks up heat from aft OD heat shield 50, the velocity decreases. Once the velocity decreases such that heat transfer heat from aft OD heat shield 50 is nearly insufficient, the flow of cooling air F_c flows through row of film cooling holes 76 and on to shield hot side 74 to produce a protective cooling film on shield hot side 74.

By employing jet wall 70 to form a wall shear jet to increase the velocity of the flow of cooling air F_c across aft OD heat shield 50, efficient use is made of the flow of cooling air F_c , thus reducing the cooling air required to cool combustor 16. In addition, pattern of efficient use, including impingement cooling and film cooling, may be repeated along combustor liner 30, as indicated by another row of impingement holes 68' downstream from film cooling holes 76, which is followed by another pedestal array, jet wall, and row of film cooling holes (not shown). Row of impingement holes 68' is spaced sufficiently far downstream from jet wall 70 that velocity effects from jet wall 70 will have dissipated such that the wall shear jet does not interfere with the impingement cooling from row of impingement holes 68'.

Another feature for improving the efficiency of a gas turbine engine by reducing the cooling air required to cool a combustor is shown in FIGS. 5A and 5B. FIGS. 5A and 5B are further enlarged side and top sectional views, respectively, of another embodiment of a combustor liner of the combustor of FIG. 2. FIG. 5A shows combustor liner 130 separating plenum 29 and combustion chamber 40. Combustor liner 130 is identical to combustor liner 30 described above, with numbering of like elements increased by 100, except that combustor liner 130 includes convergent channel 182 instead of jet wall 70 or pedestal array 80. As shown in FIGS 5A and 5B, convergent channel 182 includes a plurality of trip strips 184 and a plurality of projecting walls 186a, 186b, 186c, and 186d. Trip strips 184 project from shield cold side 172 just far enough to create turbulent flow along shield cold side 172. Trip strips 184 run in a circumferential direction, transverse to the flow of cooling air F_c within cooling air passageway 178. Each projecting wall 186a, 186b, 186c, and 186d corresponds to one of plurality of trip strips 184, and runs parallel to, and opposite of, the corresponding one of plurality of trip strips 184. Projecting walls 186a, 186b, 186c, and 186d run in a series so that each projecting wall 186a, 186b, 186c, and 186d projects from shell hot side 166 such that the distance to which each projecting wall 186a, 186b, 186c, and 186d projects from shell hot side 166 is greater for those projecting walls 186a, 186b, 186c, and 186d that are farther from row of impingement cooling holes 168. Thus, projecting wall 186d projects the farthest from shell hot side 166, projecting wall 186c the second farthest, projecting wall 186b the third farthest, and projecting wall 186a projects the least distance from shell hot side 166. In this way, the successive gaps between each projecting wall 186a, 186b, 186c, and 186d and its corresponding trip strip 184 decrease from row of impingement holes 168, or in the downstream direction.

In operation, the flow of cooling air Fc flows into cooling air passageway 178 through row of impingement holes 168. The flow of cooling air Fc impinges upon shield cold side 172, absorbing heat and cooling aft OD heat shield 150. The flow of cooling air Fc then flows through convergent channel 182. The decreasing gaps of convergent channel 182 in the downstream direction cause an increase in the velocity of the flow of cooling air Fc. In combination with the turbulent flow created by plurality of trip strips 184, the increase in velocity increases the convective heat transfer from aft OD heat shield 150 to the flow of cooling air Fc. As the flow of cooling air Fc exits convergent channel 182 and flows along shield cold side 172, it picks up heat from aft OD heat shield 150 and the velocity decreases. Once the velocity decreases such that heat transfer heat from aft OD heat shield 150 is nearly insufficient, the flow of cooling air Fc flows through row of film cooling holes 176 and on to shield hot side 174 to produce a protective cooling film on shield hot side 174.

By employing convergent channel 182 to increase the velocity of the flow of cooling air Fc across aft OD heat shield 150, efficient use is made of the flow of cooling air Fc, thus reducing the cooling air required to cool combustor 16. In addition, pattern of efficient use, including impingement cooling and film cooling, may be repeated along combustor liner 130, as indicated by another row of impingement holes 168' downstream from film cooling holes 176, which is followed by another convergent channel and row of film cooling holes (not shown).

Another feature for improving the efficiency of a gas turbine engine by reducing the cooling air required to cool a combustor is shown in FIGS. 6A and 6B. FIGS. 6A and 6B are further enlarged side and top sectional views, respectively, of another embodiment of a combustor liner of the combustor of FIG. 2. FIG. 6A shows combustor liner 230 separating plenum 29 and combustion chamber 40. Combustor liner 230 is identical to combustor liner 30 described above, with numbering of like elements increased by 200, except that combustor liner 230 includes multi-cornered film cooling slot 290 instead of row of film cooling holes 76, optional pedestal array 280 is illustrated as more extensive than pedestal array 80, and combustor liner 230 does not include jet wall 70. As shown in FIGS 6A and 6B, multi-cornered film cooling slot 290 includes a plurality of first linear film cooling slots 292 and a plurality of second linear film cooling slots 294. Plurality of first linear film cooling slots 292 runs in a row. As illustrated, the row is in a circumferential direction. Each first linear film cooling slot 292 is angled from the row in a direction. As illustrated, first linear film cooling slots 292 are angled

about 45 degrees from the row. Plurality of second linear film cooling slots 294 also run in the same row as first plurality of linear film cooling slots 292. Each second linear film cooling slot 294 is angled from the row in a direction opposite that of each first linear film cooling slot 292. As illustrated, second linear film cooling slots 294 are angled
5 about minus 45 degrees from the row. Each of plurality of second linear film cooling slots 294 alternates with each of plurality of first linear film cooling slots 292 in the row. Alternating first linear film cooling slots 292 and second linear film cooling slots 294 are connected to form a single cooling slot, multi-point film cooling slot 290.

In operation, the flow of cooling air F_c flows into cooling air passageway
10 278 through row of impingement holes 268. The flow of cooling air F_c impinges upon shield cold side 272, absorbing heat and cooling aft OD heat shield 250. The flow of cooling air F_c then flows through pedestal array 280 where the pedestals increase the turbulence and convective heat transfer of the flow of cooling air F_c , enhancing further heat transfer from aft OD heat shield 250. Then flow of cooling air F_c flows through
15 multi-cornered film cooling slot 290 on to shield hot side 274 to produce a protective cooling film on shield hot side 274. In contrast to the protective cooling film produced by row of film cooling holes 56, the protective cooling film produced by multi-cornered film cooling slot 290 spreads out more uniformly over shield hot side 274 and does not decay as quickly.

By employing multi-cornered film cooling slot 290, the protective film of
20 the flow of cooling air F_c flowing across shield hot side 274 of aft OD heat shield 250 is more even and does not decay as quickly. Thus, multi-cornered film cooling slots 290 may be spaced farther apart, making more efficient use of the flow of cooling air F_c , thus reducing the cooling air required to cool combustor 16. As with the previous
25 embodiments, the pattern of efficient use may be repeated along combustor liner 230.

Each of the four features describe above, overlapping dilution openings
56 jet wall 70, convergent channel 182, and multi-cornered film cooling slot 290, improve the efficiency of a gas turbine engine by reducing the cooling air required to cool a combustor. However, even greater efficiency is achieved by combining two or
30 more of the four features. Thus, it is understood that the present invention encompasses embodiments that combine any of these four features. One example illustrating the combination of features is shown in FIGS. 7A and 7B. FIGS. 7A and 7B are further enlarged side and top sectional views, respectively, of another embodiment of a combustor liner of the combustor of FIG. 2. The embodiment illustrated in FIGS. 7A

and 7B combines jet wall 70 and multi-cornered film cooling slot 290. Though not shown in FIGS. 7A and 7B, this embodiment also includes dilution openings 56 as described above in reference to FIG. 3. Thus, three of the four features described above are included in this embodiment.

5 Combustor liner 330 is identical to combustor liner 30 described above in reference to FIGS. 4A and 4B, with numbering of like elements increased by 300, except that combustor liner 330 includes multi-cornered film cooling slot 390 instead of row of film cooling holes 76. Multi-cornered film cooling slot 390 is identical to multi-cornered film cooling slot 290 described above in reference to FIGS. 6A and 6B, with numbering
10 of like elements increased by 100.

In operation, the flow of cooling air F_c flows into cooling air passageway 378 through row of impingement holes 368. The flow of cooling air F_c impinges upon shield cold side 372, absorbing heat and cooling aft OD heat shield 350. The flow of cooling air F_c then flows through pedestal array 380 where the pedestals increase the
15 turbulence and convective heat transfer of the flow of cooling air F_c , enhancing further heat transfer from aft OD heat shield 350. The flow of cooling air F_c then flows through the gap between jet wall 370 and shield cold side 372. The large reduction in the area available for the flow of cooling air F_c presented by jet wall 370 results in a large increase in the velocity of the flow of cooling air F_c issuing from jet wall 370 and along
20 shield cold side 372 in the tangential or shear direction. The resulting wall shear jet greatly increases the convective heat transfer between the flow of cooling air F_c and aft OD heat shield 350. As the flow of cooling air F_c flows along shield cold side 372 and picks up heat from aft OD heat shield 350, the velocity decreases. Once the velocity decreases such that heat transfer heat from aft OD heat shield 350 is nearly insufficient,
25 the flow of cooling air F_c flows through multi-cornered film cooling slot 390 on to shield hot side 374 to produce a protective cooling film on shield hot side 374.

Employing both jet wall 370 and multi-cornered film cooling slot 390, combustor liner 330 obtains the benefits of both features resulting in a greater reduction in the cooling air required to cool combustor 16. As with the previous embodiments, the
30 pattern of efficient use may be repeated along combustor liner 330. Adding dilution openings 56 as described above in reference to FIG. 3 to combustor liner 330 to produce dilution jets within combustion chamber 40 in a staggered, overlapping arrangement results in an even greater reduction in cooling air requirements.

Another example illustrating the combination of features is shown in FIGS. 8A and 8B. FIGS. 8A and 8B are further enlarged side and top sectional views, respectively, of another embodiment of a combustor liner of the combustor of FIG. 2. The embodiment illustrated in FIGS. 8A and 8B adds convergent channel 482 to the
5 embodiment describe above in reference to FIGS. 7A and 7B.

Combustor liner 430 is identical to combustor liner 330 described above, with numbering of like elements increased by 100, except that combustor liner 430 replaces pedestal array 380 with convergent channel 482. Convergent channel 482 is identical to convergent channel 182 as described above in reference to FIGS. 5A and 5B
10 with numbering of like elements increased by 100.

In operation, the flow of cooling air Fc flows into cooling air passageway 478 through row of impingement holes 468. The flow of cooling air Fc impinges upon shield cold side 472, absorbing heat and cooling aft OD heat shield 450. The flow of cooling air Fc then flows through convergent channel 482. The decreasing gaps of
15 convergent channel 482 in the downstream direction cause an increase in the velocity of the flow of cooling air Fc. In combination with the turbulent flow created by plurality of trip strips 484, the increase in velocity increases the convective heat transfer from aft OD heat shield 450 to the flow of cooling air Fc. As the flow of cooling air Fc exits convergent channel 482 and flows along shield cold side 472, it picks up heat from aft
20 OD heat shield 450 and the velocity decreases. The flow of cooling air Fc then flows through the gap between jet wall 470 and shield cold side 472. The large reduction in the area available for the flow of cooling air Fc presented by jet wall 470 results in a large increase in the velocity of the flow of cooling air Fc issuing from jet wall 470 and along shield cold side 472 in the tangential or shear direction. The resulting wall shear
25 jet greatly increases the convective heat transfer between the flow of cooling air Fc and aft OD heat shield 450. As the flow of cooling air Fc flows along shield cold side 472 and picks up heat from aft OD heat shield 450, the velocity decreases. Once the velocity decreases such that heat transfer heat from aft OD heat shield 450 is nearly insufficient, the flow of cooling air Fc flows through multi-cornered film cooling slot 490 on to shield
30 hot side 474 to produce a protective cooling film on shield hot side 474.

By employing convergent channel 482 in addition to jet wall 470, multi-cornered film cooling slot 490, and dilution openings 56, combustor liner 430 obtains the benefits of all features resulting in largest reduction in the cooling air required to cool

combustor 16. As with the previous embodiments, the pattern of efficient use may be repeated along combustor liner 430.

For the sake of brevity, all embodiments above are illustrated with respect to an aft outer diameter portion of a combustion liner. However, it is understood that
5 embodiments encompassed by the present invention include other portions of the combustion liner, such as the aft inner diameter, forward outer diameter, and forward inner diameter portions.

Embodiments of the present invention improve the efficiency of a gas turbine engine by reducing the cooling air required to cool a combustor. Combustor
10 liners may include any or all of four features: dilution openings in a staggered, overlapping arrangement, a convergent channel within the combustor liner, a jet wall within the combustor liner, and a multi-cornered cooling film slot. Dilution openings in a staggered, overlapping arrangement provide full circumferential coverage around a combustor and eliminate high-heat flux areas downstream of the dilution openings. A
15 convergent channel within the liner increases cooling flow velocity and improves convective heat transfer from the combustor liner. A jet wall within the liner also increases the velocity of cooling air by creating a wall shear jet across the surface within the combustor liner. Finally, a multi-cornered film cooling slot forms a film cooling layer that spreads out to uniformly cover the surface of the liner facing the combustion
20 chamber. The uniform film cooling layer also decays more slowly, so multi-cornered film cooling slots may be spaced farther apart. Together, the staggered dilution openings, convergent channel, wall shear jet, and multi-cornered film cooling slot significantly reduce the cooling air requirements of a combustor and improve the fuel efficiency of a gas turbine engine.

25 While the invention has been described with reference to an exemplary embodiment(s), it will be understood by those skilled in the art that various changes may be made and equivalents may be substituted for elements thereof without departing from the scope of the invention. In addition, many modifications may be made to adapt a particular situation or material to the teachings of the invention without departing from
30 the essential scope thereof. Therefore, it is intended that the invention not be limited to the particular embodiment(s) disclosed, but that the invention will include all embodiments falling within the scope of the appended claims.

Discussion of Possible Embodiments

The following are non-exclusive descriptions of possible embodiments of the present invention.

5 A shell for a combustor liner can include a cold side, a hot side, a row of cooling holes in the shell, and a jet wall; the jet wall projecting from the hot side for creating a wall shear jet of increased velocity cooling flow in a tangential direction away from the row of cooling holes and along an adjacent heat shield cold side wall.

The component of the preceding paragraph can optionally include, additionally and/or alternatively, any one or more of the following features, configurations and/or additional components:

10 a pedestal array between the row of cooling holes and the jet wall;
a plurality of rows of cooling holes in the shell; and a plurality of jet walls projecting from the hot side, the jet walls and the rows of cooling holes alternating across the shell for creating a series of wall shear jet cooling flows in a tangential direction along the adjacent heat shield cold side wall;

15 the shell is arcuate in shape defining an axis and a circumferential direction, and the jet wall runs in a circumferential direction;

a first row of dilution openings in the shell, the first row of dilution openings running in the circumferential direction; and a second row of dilution openings in the shell running parallel to the first row of dilution openings and axially spaced from
20 the first row of dilution openings; each dilution opening of the second row of dilution openings at least partially overlapping in an axial direction a portion of each of two adjacent dilution openings of the first row of dilution openings; and

the dilution openings are substantially rectangular.

25 A combustor liner for a gas turbine engine can include a heat shield and a shell attached to the heat shield. The heat shield includes a shield hot side and a shield cold side. The shell includes a shell hot side facing the shield cold side; a shell cold side facing away from the shield hot side; a row of cooling holes in the shell; and a jet wall; the jet wall projecting from the hot side for creating a wall shear jet of increased velocity cooling flow in a tangential direction away from the row of cooling holes and along the
30 heat shield cold side.

The component of the preceding paragraph can optionally include, additionally and/or alternatively, any one or more of the following features, configurations and/or additional components:

a pedestal array between the row of cooling holes and the jet wall, the pedestals of the pedestal array extending from the shell hot side to the shield cold side;

a plurality of rows of cooling holes in the shell; and a plurality of jet walls projecting from the shell hot side, the jet walls and the rows of cooling holes alternating
5 across the shell for creating a series of wall shear jet cooling flows in a tangential direction along the adjacent shield cold side;

the combustor liner is arcuate in shape defining an axis and a circumferential direction, and the jet wall runs in a circumferential direction;

a first row of dilution openings in the liner, the first row of dilution
10 openings running in the circumferential direction; and a second row of dilution openings in the liner, the second row of dilution openings running parallel to the first row of dilution openings and axially spaced from the first row of dilution openings; each dilution opening of the second row of dilution openings at least partially overlapping in an axial direction a portion of each of two adjacent dilution openings of the first row of
15 dilution openings;

the dilution openings are substantially rectangular;

the heat shield further includes: a plurality of first linear film cooling slots through the heat shield, the first linear film cooling slots angled in a first axial direction and disposed in a row running in the circumferential direction; and a plurality of second
20 linear film cooling slots through the heat shield, the second linear film cooling slots angled in a second axial direction opposite to the first axial direction, and alternating with first linear film cooling slots in the row; the first and second linear film cooling slots connected to form a single, multi-cornered film cooling slot downstream from the jet wall; and

25 the plurality of first linear film cooling slots are angled at about 45 degrees in the axial direction from the circumferential direction; and the second linear film cooling slots are angled at about minus 45 degrees in the axial direction from the circumferential direction.

A method of cooling a combustor liner of a gas turbine engine can include
30 providing cooling air to the combustor liner; flowing the cooling air to an interior of the combustor liner through a row of cooling holes; flowing the cooling air onto a portion of a surface within the combustor liner to cool the surface; flowing the cooling air within the combustor liner to a jet wall to cool the combustor liner between the cooling holes and the jet wall; increasing the velocity of the cooling air by passing it between a gap

between the jet wall and the surface within the combustor liner to form a wall shear jet; and cooling a portion of the surface within the combustor liner beyond the jet wall with the increased velocity cooling air from the wall shear jet.

The method of the preceding paragraph can optionally include, additionally and/or alternatively, any one or more of the following features, configurations and/or additional components:

flowing the cooling air within the combustor liner to a jet wall to cool the combustor liner between the cooling holes and the jet wall includes passing the cooling air through an array of pedestals to increase the turbulence of the cooling air;

flowing the cooling air through dilution openings in the combustor liner to create a first row of dilution jets at an exterior of the combustor liner; flowing the cooling air through dilution openings in the combustor liner to create a second row of dilution jets at the exterior of the combustor liner in a staggered, overlapping relationship with first row of dilution jets; producing staggered, overlapping dilution jets at the exterior of the combustor liner; and creating an even dilution air flow pressure distribution from the staggered, overlapping dilution air jets to promote cooling by eliminating hot spots on a portion of the exterior of the combustor liner; and

flowing the cooling air from the wall shear jet to a multi-cornered film cooling slot leading from the interior of the combustor liner to the exterior of the combustor liner; passing the cooling air through the multi-cornered film cooling slot; flowing the cooling air out of the multi-cornered film cooling slot; and forming a cooling film on the exterior of the combustor liner.

CLAIMS:

1. A shell for a combustor liner, the shell comprising:
a cold side;
a hot side;
5 a row of cooling holes in the shell; and
a jet wall projecting from the hot side for creating a wall shear jet of increased velocity cooling flow in a tangential direction away from the row of cooling holes and along an adjacent heat shield cold side wall.
- 10 2. The shell of claim 1, further comprising a pedestal array between the row of cooling holes and the jet wall.
3. The shell of claim 1, further comprising:
a plurality of rows of cooling holes in the shell; and
a plurality of jet walls projecting from the hot side, the jet walls and the
15 rows of cooling holes alternating across the shell for creating a series of wall shear jet cooling flows in a tangential direction along the adjacent heat shield cold side wall.
4. The shell of claim 1, wherein the shell is arcuate in shape defining an axis and a circumferential direction, and the jet wall runs in a circumferential direction.
- 20 5. The shell of claim 4, further comprising:
a first row of dilution openings in the shell, the first row of dilution openings running in the circumferential direction; and
a second row of dilution openings in the shell running parallel to the first
25 row of dilution openings and axially spaced from the first row of dilution openings; each dilution opening of the second row of dilution openings at least partially overlapping in an axial direction a portion of each of two adjacent dilution openings of the first row of dilution openings.
6. The shell of claim 5, wherein the dilution openings are substantially
30 rectangular.
7. A combustor liner for a gas turbine engine, the combustor liner comprising:
a heat shield including:
a shield hot side; and

- a shield cold side; and
a shell attached to the heat shield, the shell including:
a shell hot side facing the shield cold side;
a shell cold side facing away from the shield cold side;
5 a row of cooling holes in the shell; and
a jet wall projecting from the shell hot side for creating a wall
shear jet of increased velocity cooling flow in a tangential
direction away from the row of cooling holes and along the
shield cold side.
- 10 8. The combustor liner of claim 7, further comprising a pedestal array
between the row of cooling holes and the jet wall, the pedestals of the pedestal array
extending from the shell hot side to the shield cold side.
9. The combustor liner of claim 7, wherein the shell further includes:
a plurality of rows of cooling holes in the shell; and
15 a plurality of jet walls projecting from the shell hot side, the jet walls and
the rows of cooling holes alternating across the shell for creating a
series of wall shear jet cooling flows in a tangential direction
along the adjacent shield cold side.
10. The combustor liner of claim 7, wherein the combustor liner is arcuate in
20 shape defining an axis and a circumferential direction, and the jet wall runs in a
circumferential direction.
11. The combustor liner of claim 10, further comprising
a first row of dilution openings in the liner, the first row of dilution
openings running in the circumferential direction; and
25 a second row of dilution openings in the liner, the second row of dilution
openings running parallel to the first row of dilution openings and
axially spaced from the first row of dilution openings; each
dilution opening of the second row of dilution openings at least
partially overlapping in an axial direction a portion of each of two
30 adjacent dilution openings of the first row of dilution openings.
12. The combustor liner of claim 11, wherein the dilution openings are
substantially rectangular.
13. The combustor liner of claim 10, wherein the heat shield further includes:

- a plurality of first linear film cooling slots through the heat shield, the first linear film cooling slots angled in a first axial direction and disposed in a row running in the circumferential direction; and
- 5 a plurality of second linear film cooling slots through the heat shield, the second linear film cooling slots angled in a second axial direction opposite to the first axial direction, and alternating with first linear film cooling slots in the row; the first and second linear film cooling slots connected to form a single, multi-cornered film cooling slot downstream from the jet wall.
- 10 14. The combustor liner of claim 13, wherein the plurality of first linear film cooling slots are angled at about 45 degrees in the axial direction from the circumferential direction; and the second linear film cooling slots are angled at about minus 45 degrees in the axial direction from the circumferential direction.
- 15 15. The combustor liner of claim 13, further comprising a first row of dilution openings in the liner, the first row of dilution openings running in the circumferential direction; and a second row of dilution openings in the liner, the second row of dilution openings running parallel to the first row of dilution openings and axially spaced from the first row of dilution openings; each
- 20 dilution opening of the second row of dilution openings at least partially overlapping in an axial direction a portion of each of two adjacent dilution openings of the first row of dilution openings.
16. A method of cooling a combustor liner of a gas turbine engine comprises: providing cooling air to the combustor liner;
- 25 flowing the cooling air to an interior of the combustor liner through a row of cooling holes;
- flowing the cooling air onto a portion of a surface within the combustor liner to cool the surface;
- 30 flowing the cooling air within the combustor liner to a jet wall to cool the combustor liner between the cooling holes and the jet wall;
- increasing the velocity of the cooling air by passing it between a gap between the jet wall and the surface within the combustor liner to form a wall shear jet; and

cooling a portion of the surface within the combustor liner beyond the jet wall with the increased velocity cooling air from the wall shear jet.

17. The method of claim 16 in which flowing the cooling air within the combustor liner to a jet wall to cool the combustor liner between the cooling holes and the jet wall includes:

passing the cooling air through an array of pedestals to increase the turbulence of the cooling air.

18. The method of claim 16, further comprising:

flowing the cooling air through dilution openings in the combustor liner to create a first row of dilution jets at an exterior of the combustor liner;

flowing the cooling air through dilution openings in the combustor liner to create a second row of dilution jets at the exterior of the combustor liner in a staggered, overlapping relationship with first row of dilution jets;

producing staggered, overlapping dilution jets at the exterior of the combustor liner; and

creating an even dilution air flow pressure distribution from the staggered, overlapping dilution air jets to promote cooling by eliminating hot spots on a portion of the exterior of the combustor liner.

19. The method of claim 16, further comprising:

flowing the cooling air from the wall shear jet to a multi-cornered film cooling slot leading from the interior of the combustor liner to the exterior of the combustor liner;

passing the cooling air through the multi-cornered film cooling slot;

flowing the cooling air out of the multi-cornered film cooling slot; and

forming a cooling film on the exterior of the combustor liner.

20. The method of claim 19, further comprising:

flowing the cooling air through dilution openings in the combustor liner to create a first row of dilution jets at an exterior of the combustor liner;

flowing the cooling air through dilution openings in the combustor liner to create a second row of dilution jets at the exterior of the

- combustor liner in a staggered, overlapping relationship with first row of dilution jets;
- producing staggered, overlapping dilution jets at the exterior of the combustor liner; and
- 5 creating an even dilution air flow pressure distribution from the staggered, overlapping dilution air jets to promote cooling by eliminating hot spots on a portion of the exterior of the combustor liner.

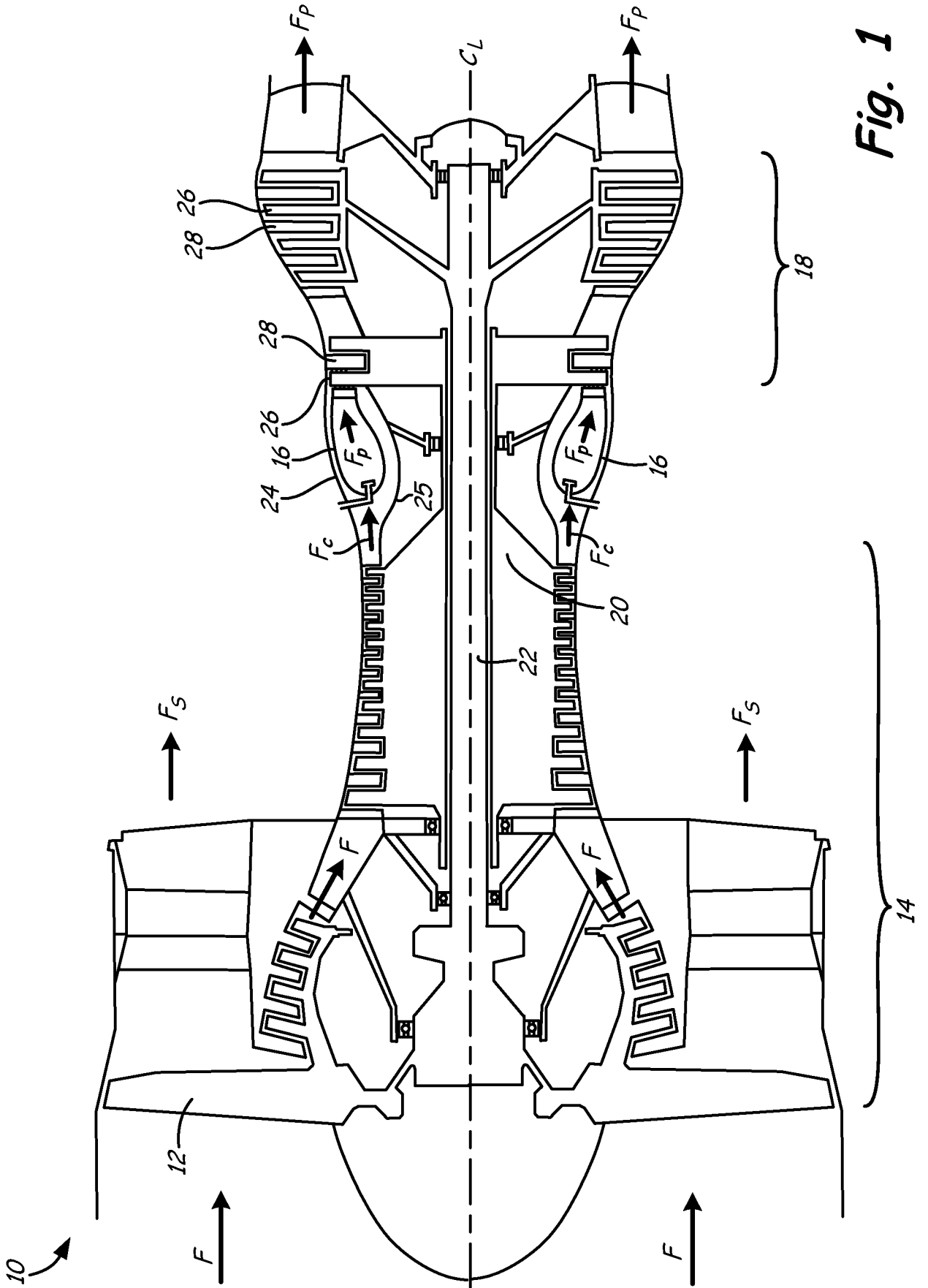

Fig. 1

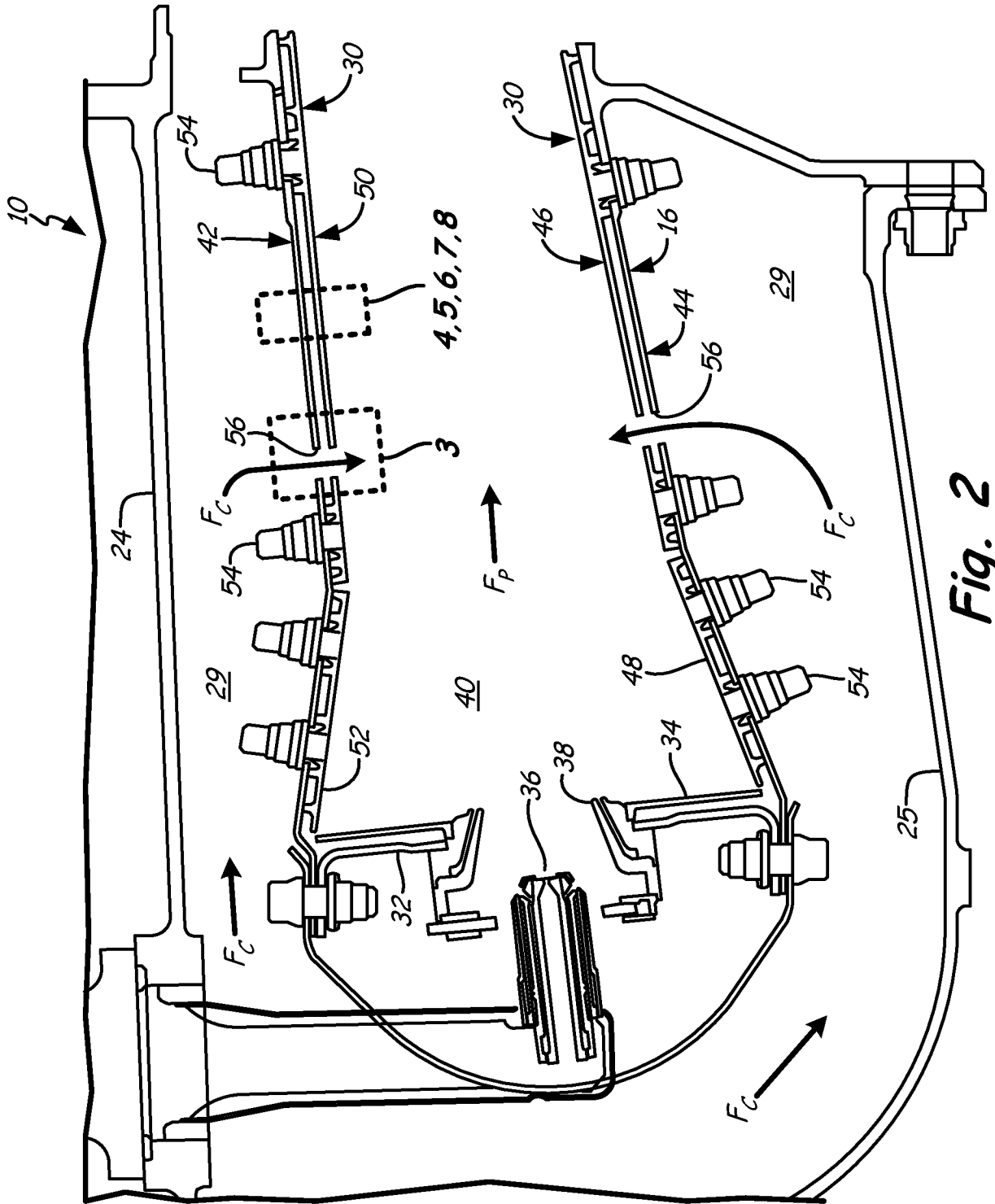

Fig. 2

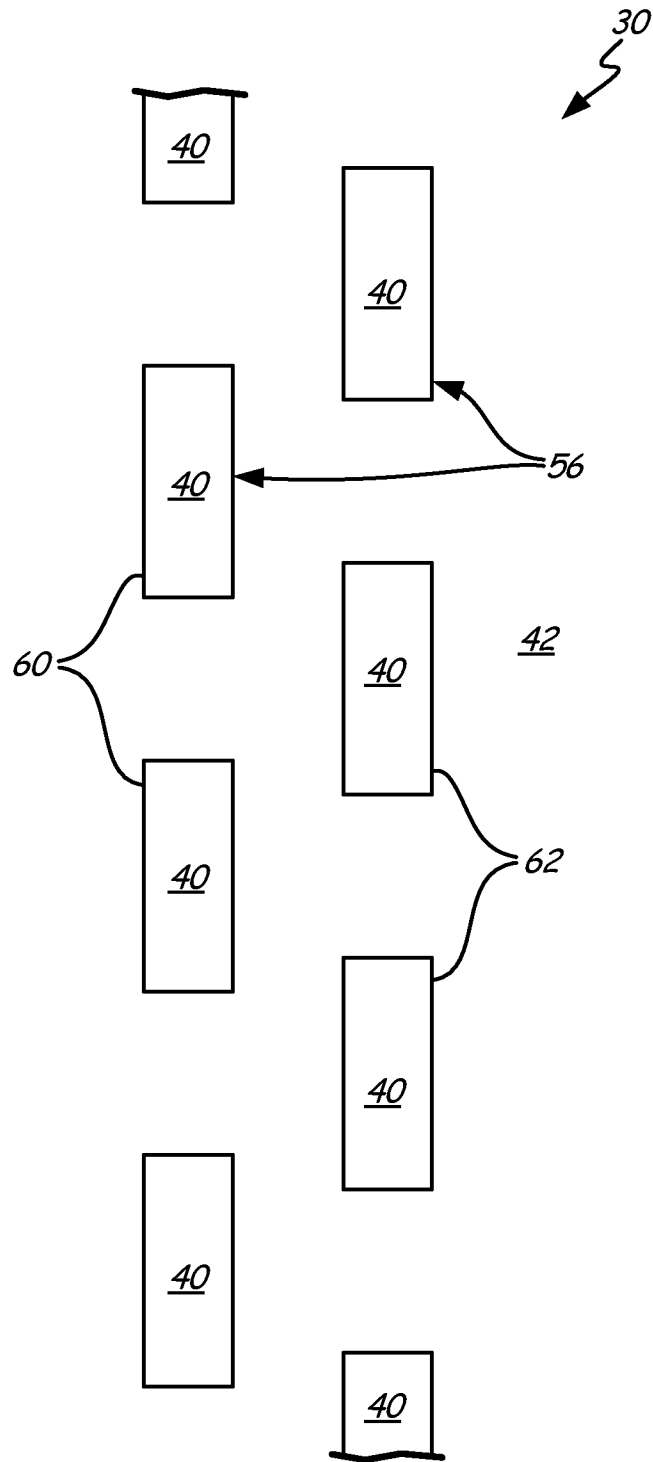
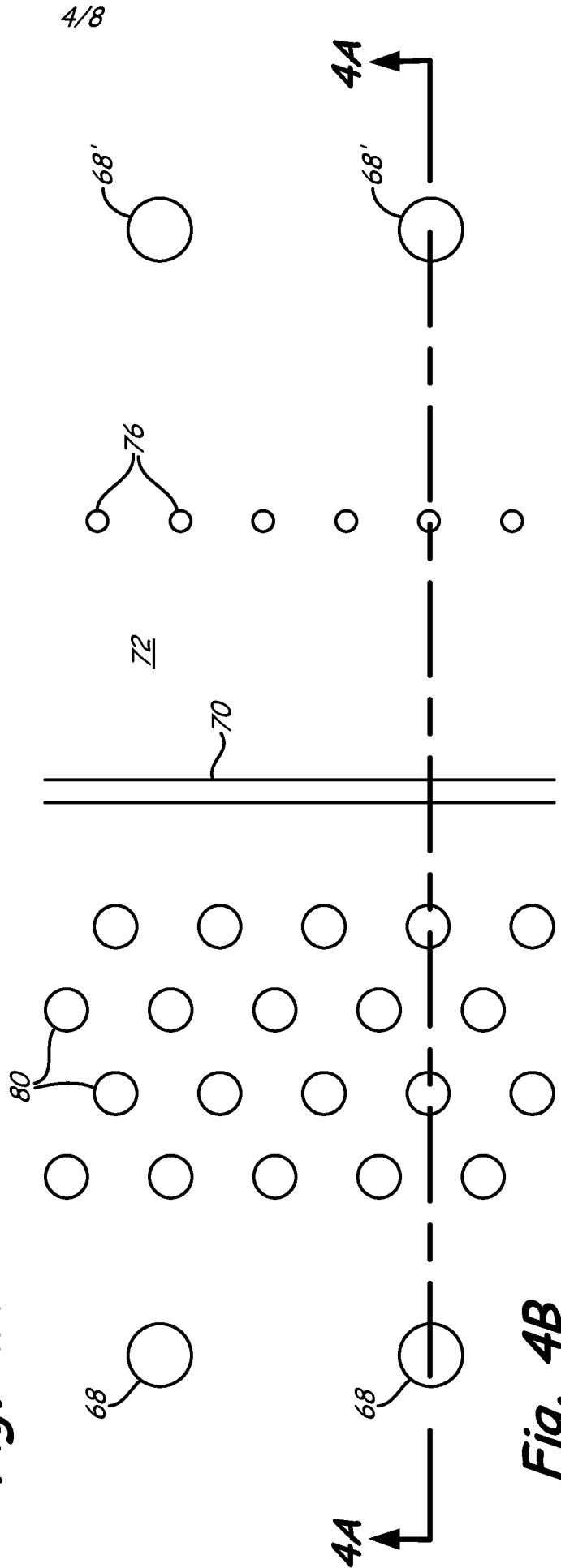
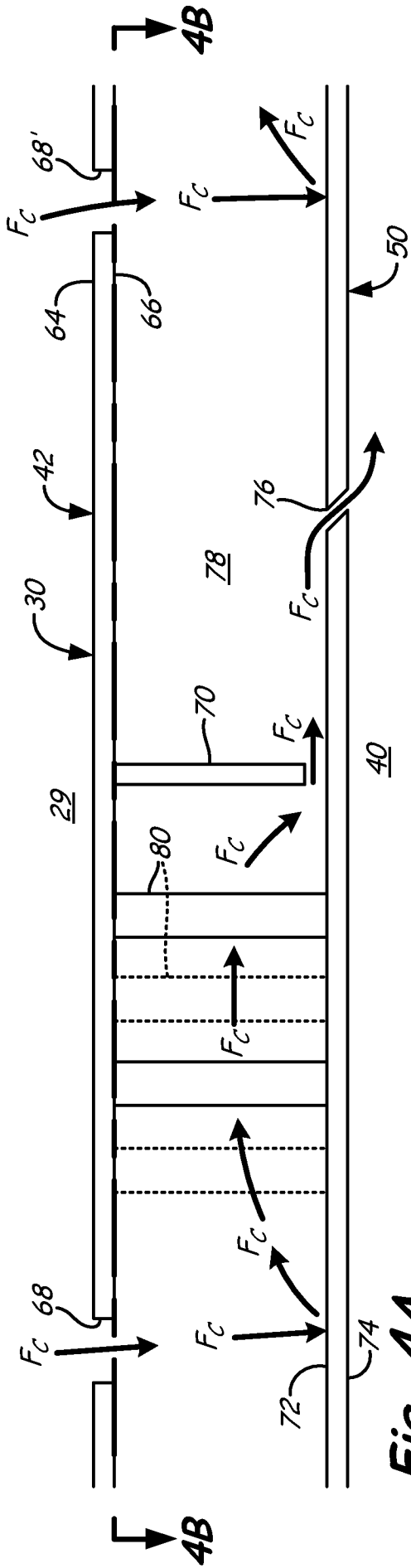
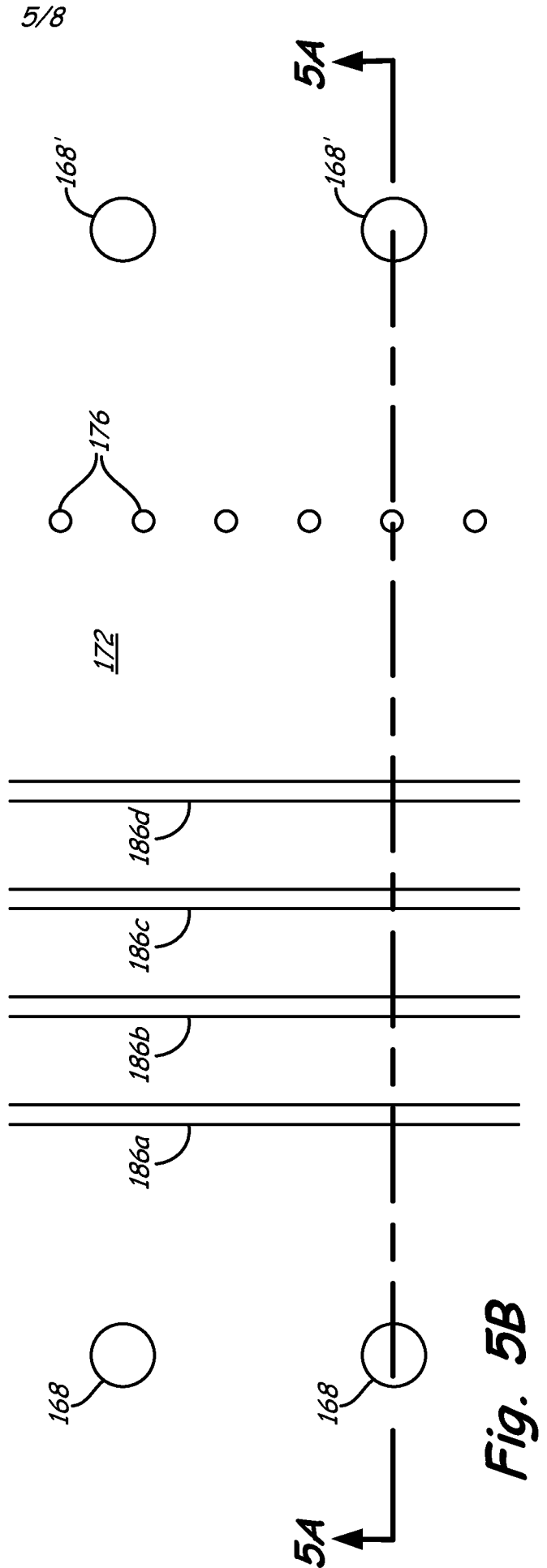
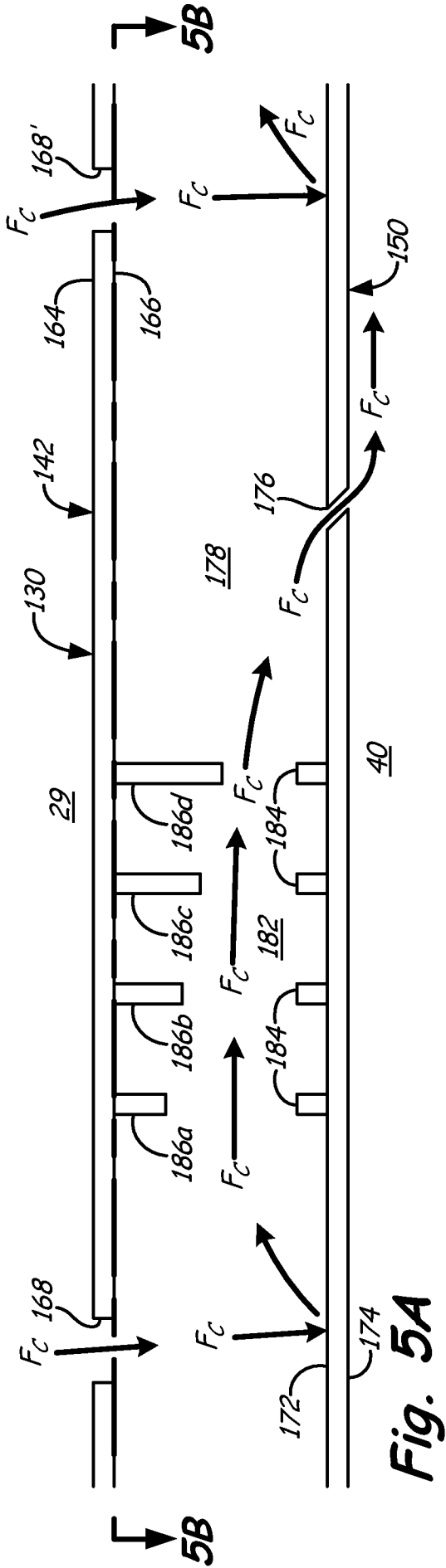

Fig. 3





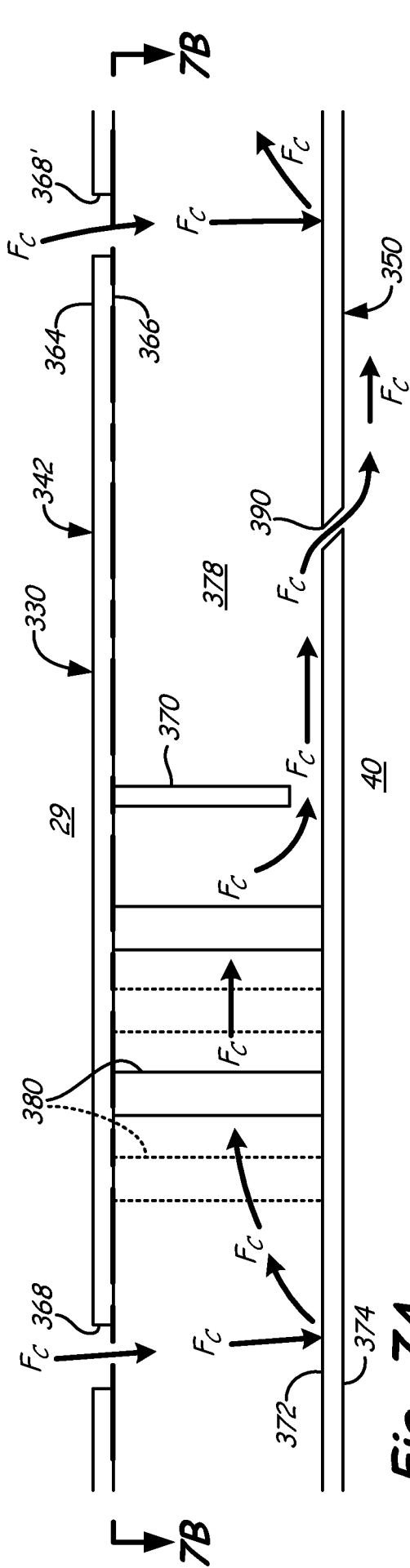

Fig. 7A

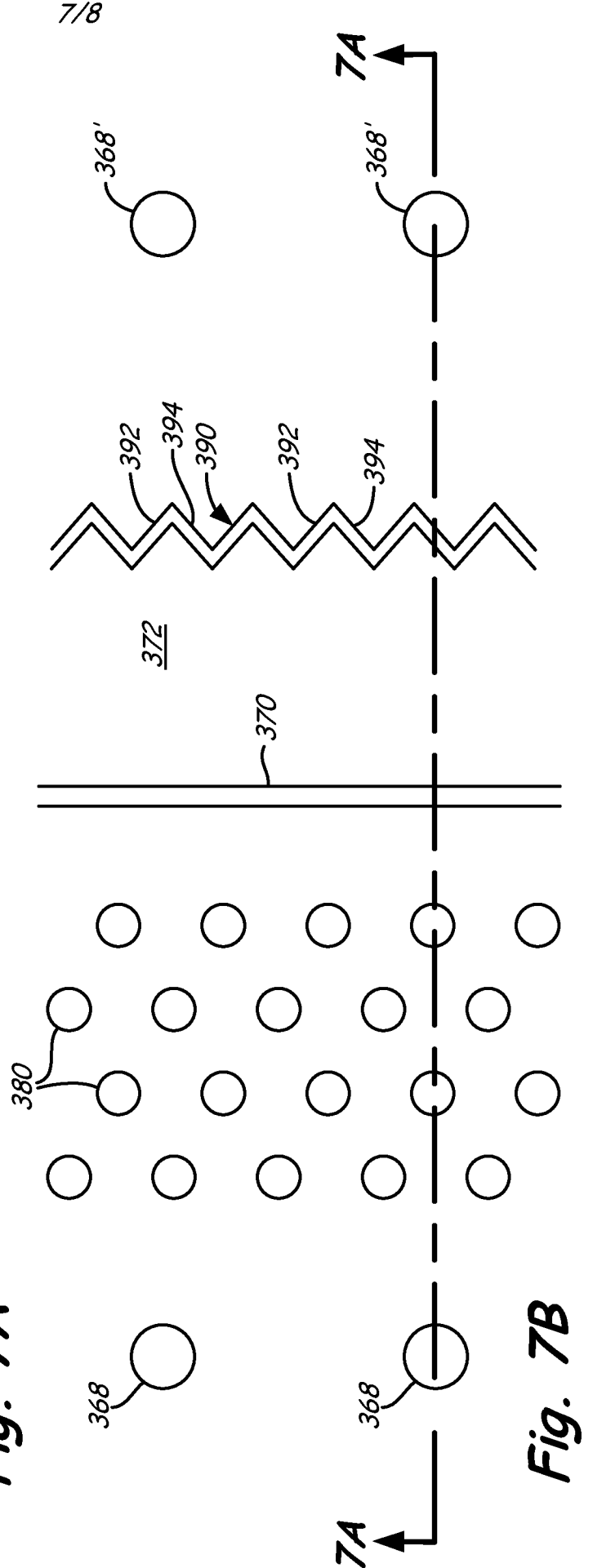

Fig. 7B

