

(19) World Intellectual Property Organization  
International Bureau



(43) International Publication Date  
16 August 2001 (16.08.2001)

PCT

(10) International Publication Number  
**WO 01/58388 A1**

- (51) International Patent Classification<sup>7</sup>: **A61F 2/48, 5/48** (74) Agents: **HAGSTRÖM, Leif** et al.; Bergenstråhle & Lindvall AB, P.O. Box 17704, S-118 93 Stockholm (SE).
- (21) International Application Number: PCT/SE01/00270 (81) Designated States (national): AE, AG, AL, AM, AT, AU, AZ, BA, BB, BG, BR, BY, BZ, CA, CH, CN, CR, CU, CZ, DE, DK, DM, DZ, EE, ES, FI, GB, GD, GE, GH, GM, HR, HU, ID, IL, IN, IS, JP, KE, KG, KP, KR, KZ, LC, LK, LR, LS, LT, LU, LV, MA, MD, MG, MK, MN, MW, MX, MY, NZ, NO, NZ, PL, PT, RO, RU, SD, SE, SG, SI, SK, SL, TJ, TM, TR, TT, TZ, UA, UG, US, UZ, VN, YU, ZA, ZW.
- (22) International Filing Date: 9 February 2001 (09.02.2001)
- (25) Filing Language: English
- (26) Publication Language: English
- (30) Priority Data:  
60/181,469 10 February 2000 (10.02.2000) US  
60/181,550 10 February 2000 (10.02.2000) US
- (71) Applicant (for all designated States except US): **SURGICAL DEVELOPMENT AG** [CH/CH]; Zugerstrasse 74, CH-6341 Baar (CH).
- (84) Designated States (regional): ARIPO patent (GH, GM, KE, LS, MW, MZ, SD, SL, SZ, TZ, UG, ZW), Eurasian patent (AM, AZ, BY, KG, KZ, MD, RU, TJ, TM), European patent (AT, BE, CH, CY, DE, DK, ES, FI, FR, GB, GR, IE, IT, LU, MC, NL, PT, SE, TR), OAPI patent (BF, BJ, CF, CG, CI, CM, GA, GN, GW, ML, MR, NE, SN, TD, TG).

**Published:**

- with international search report
- before the expiration of the time limit for amending the claims and to be republished in the event of receipt of amendments

[Continued on next page]

(54) Title: URINARY INCONTINENCE TREATMENT WITH WIRELESS ENERGY SUPPLY

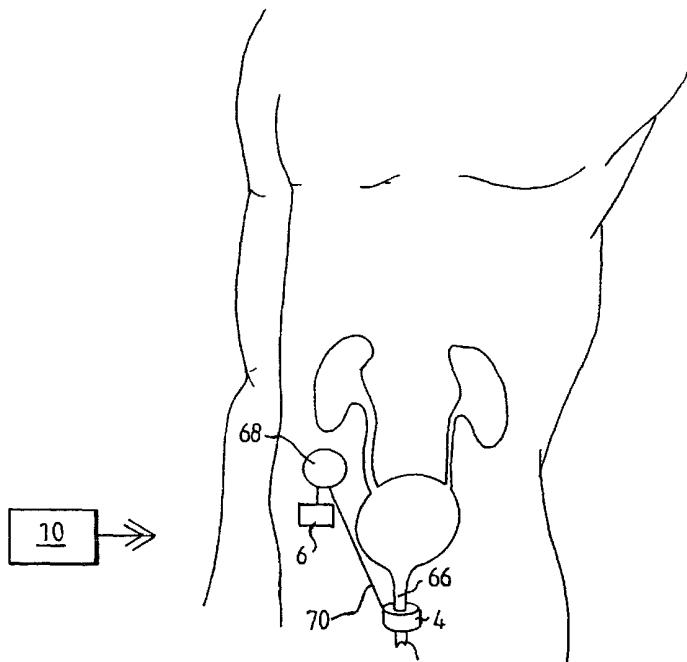

(57) Abstract: A urinary incontinence treatment apparatus comprises an operable restriction device (4) to be implanted in a patient for engaging the urethra (66) or urine bladder, to form a restricted urine passageway in the urethra or urine bladder. The restriction device is operable to change the restriction of the urine passageway. An energy transmission device (10) is provided for wireless transmission of energy from outside the patient's body to inside the patient's body for use in connection with the operation of the restriction device including enlarging or restricting the urine passageway.



**WO 01/58388 A1**



---

*For two-letter codes and other abbreviations, refer to the "Guidance Notes on Codes and Abbreviations" appearing at the beginning of each regular issue of the PCT Gazette.*

**URINARY INCONTINENCE TREATMENT WITH WIRELESS ENERGY  
SUPPLY**

5           The present invention relates to a urinary incontinence treatment apparatus comprising an operable restriction device implantable in a patient, who suffers from urinary incontinence, for engaging the urethra or urine bladder, to form a restricted urine passageway in the urethra or urine bladder. The restriction  
10 device is operable to change the restriction of the urine passageway, i.e. to close and enlarge the urine passageway. The term "patient" includes an animal or a human being.

          Urine incontinence is a widespread problem. Many people are helped through training of the muscles in the pelvic floor but  
15 too many have severe problems with urine leakage. Many different solutions to this problem have been tried. For example, there is a prior manually operated urine incontinence treatment apparatus having an artificial hydraulic sphincter device engaging the urethra and connected to an elastic reservoir implanted in the  
20 scrotum or in the region of the labia major. A disadvantage of this prior apparatus is that over time hard fibrosis is developed around the reservoir, which may cause malfunction of pumping components. Furthermore, it is a rather complicated task to manually squeeze the elastic implanted reservoir to pump  
25 hydraulic fluid to open the sphincter device when the patient needs to urinate. In particular women can get their fingers wet. The created fibrosis will sooner or later become a hard fibroid layer, which may make it even more difficult to pump the reservoir. Yet a further disadvantage is that the use of  
30 hydraulic fluid always entails a risk of fluid leaking from implanted hydraulic components.

          A prior hydraulic apparatus designed to compress the urethra

is disclosed in U.S. Pat. No. 5520606. A prosthetic sphincter with an inflatable cuff, which surrounds the urethra or encloses it on two sides, is disclosed in for example U.S. Pat. Nos. 4571749 and 4222377. U.S. Pat. No. 4969474 discloses a hydraulic method for treating both men and women with urinary incontinence problems in the same way. The apparatus of U.S. Pat. No. 4969474 includes a reservoir containing fluid and an inflatable compression means designed to compress urethra without risking tissue loss or necrosis to occur. An artificial hydraulically operated urethra sphincter employing an external magnet to achieve closure of the urethra cuff is disclosed in U.S. Pat. No. 5562598.

A prior mechanical prosthetic sphincter disclosed in U.S. Pat. No. 4619245 comprises a manually controllable actuating component for implanting at a convenient location in the patient's body.

The object of the present invention is to provide a new convenient urinary incontinence treatment apparatus, the performance of which may be affected by the patient at any time after operation, in particular when various needs arise over the course of a day, so that the patient substantially always is satisfied or comfortable.

This object is achieved by a urinary incontinence treatment apparatus of the kind stated initially characterised by an energy transmission device for wireless transmission of energy from outside the patient's body to inside the patient's body for use in connection with the operation of the restriction device including enlarging or restricting the urine passageway, when the restriction device is implanted.

As a result, the advantage is achieved that the urinary incontinence treatment apparatus of the invention provides simple

and effective energy transmission that ensures long reliable function of the apparatus, possibly for the rest of the patient's life.

Generally, the apparatus comprises an energy transforming device implantable in the patient for transforming the energy wirelessly transmitted by the energy transmission device from a first form into a second form, preferably different than the first form.

The energy transforming device may comprise at least one semiconductor type of component or a circuitry of such semiconductor components. The semiconductor component may comprise a transistor or microchip or similar electronic components. However, the semiconductor component may not comprise rectifying diodes.

In accordance with a main embodiment of the invention, the energy transforming device comprises at least one element having a positive region and a negative region and adapted to create an energy field between the positive and negative regions when exposed to the energy of the first form transmitted by the energy transmission device, so that the energy field provides the energy of the second form. Typically, the above-mentioned semiconductor component may include such an element.

In accordance with a preferred embodiment of the invention, the element comprises an electrical junction element capable of inducing an electric field between the positive and negative regions when exposed to the energy of the first form transmitted by the energy transmission device, whereby the energy of the second form comprises electric energy.

Consequently, the restriction device suitably is electrically operated, whereby the positive and negative regions of the electrical junction element supply electric energy for the operation of the restriction device. The apparatus suitably

comprises implantable electric conductors connected to the positive and negative regions of the electrical junction element, whereby the electrical junction element is capable of supplying an electric current, such as a direct current, a pulsating direct current, a combination of a direct and pulsating direct current, 5 an alternating current or a combination of a direct and alternating current, via the conductors. Furthermore, the electrical junction element may be capable of supplying a frequency, amplitude, or frequency and amplitude modulated analog, digital, or a combination of analog and digital signal, 10 which is used in connection with control of the restriction device.

The element, preferably in the form of an electrical semiconductor junction element, should be designed to generate 15 an output current exceeding 1  $\mu\text{A}$  when exposed to the energy of the first form transmitted by the energy transmission device. Suitably the electrical junction element forms a flat and thin sheet and has a volume of less than 2000  $\text{cm}^3$  to be suited for subcutaneous implantation, so that the electrical junction 20 element can be located just behind the skin of the patient. Alternatively, it would be possible to implant the element in the thorax or cephalic region of the patient, or in an orifice of the patient's body and under the mucosa or intraluminal outside the mucosa of the orifice. Of course, all the components of the 25 energy transforming device including the electrical junction element in contact with the patient's body should be of biocompatible material.

For in vitro appliances, a particular type of an electrical semiconductor junction element has been commonly used, namely a 30 so-called p-n (positive/negative) junction element, typically in the form of solar cells. A solar cell transfers solar energy in the form of visible light into electric energy in the form of

direct current. For example, a p-n junction element may comprise two layers of semiconductor, one p-type (positive) and the other n-type (negative), sandwiched together to form a "p-n junction". This p-n junction induces an electric field across the element  
5 when absorbing quanta of light (photons).

To be more precise, the quanta of light transfer their energy to some of the semiconductor's electrons, which are then able to move about through the material. For each such negatively charged electron, a corresponding positive charge - a "hole" -  
10 is created. In an ordinary semiconductor, these electrons and holes recombine after a short time and their energy is wasted as heat. However, when the electrons and holes are swept across the p-n junction in opposite directions by the action of the electric field, the separation of charge induces a voltage across the p-n  
15 junction element. By connecting the p-n junction element to an external circuit, the electrons are able to flow thereby creating a current.

Surprisingly, it has been proved that although both the skin and subcutis absorb energy from an external light beam directed  
20 against the skin portion behind which a properly designed p-n junction element is located, the light energy transmitted through the skin can induce a current from the p-n junction element strong enough (minimum 1  $\mu$ A) to enable the operation of the electrically operated restriction device. Thus, such a p-n  
25 junction element is now for the first time used for in vivo applications.

The apparatus may comprise an implantable pulse generator for generating electrical pulses from the energy of the second form produced by the energy field.

30 Generally, the energy transforming device is adapted to transform the energy of the first form directly or indirectly into the energy of the second form.

In accordance with a preferred embodiment of the invention, the energy of the second form comprises electric energy and the energy transforming device comprises a capacitor, which may be adapted to produce electric pulses from the transformed electric energy. Preferably, the capacitor may be adapted to produce the pulses as the energy transforming device transforms the energy of the first form transmitted by the energy transmission device into the electric energy of the second form. The capacitor should be small to facilitate implantation thereof; i.e. its capacity may not be more than 0,1  $\mu\text{F}$ .

The apparatus may comprise an implantable stabiliser for stabilising the energy of the second form. Where the energy of the second form comprises electric current the stabiliser may comprise at least one capacitor of the type described above.

In most embodiments of the invention, the apparatus comprises implantable electrical components. Where the electrical components include a capacitor of the type described above or an accumulator, at least one, preferably a single, voltage level guard may advantageously be provided, wherein the charge and discharge of the capacitor or accumulator is controlled by use of the voltage level guard. As a result, there is no need for any implanted current detector and/or charge level detector for the control of the capacitor, which makes the apparatus simple and reliable.

In a particular embodiment of the invention, the wireless energy of the first form comprises sound waves and the energy of the second form comprises electric energy, wherein the energy transforming device is adapted to directly transform the sound waves into electric energy.

The apparatus may comprise an implantable motor or pump for operating the restriction device, wherein the motor or pump is powered by the transformed energy.



In accordance with a main aspect of the invention, the energy transmission device may be adapted to transmit wireless energy for direct use in connection with the operation of the restriction device, as the wireless energy is being transmitted.

5 The advantage of directly using energy as it is transmitted is that the apparatus can be of a very simple design and the few components involved makes the apparatus extremely reliable. For example, the energy transmission device may be adapted to directly power the motor or pump with wireless energy. The

10 wireless energy may comprise a magnetic field or electromagnetic waves, suitably in the form of a signal, for direct power of the motor or pump. All the various functions of the motor and associated components described in the present specification may be used where applicable.

15 As an alternative to the above-noted main aspect of the invention, the energy transforming device may be adapted to supply the energy of the second form for direct use in connection with the operation of the restriction device, as the energy of the first form is being transformed into the energy of the second

20 form. Consequently, the energy transforming device may be adapted to directly power the motor or pump with the energy of the second form.

Generally, the energy transforming device directly operates the restriction device with the energy of the second form in a

25 non-magnetic, non-thermal or non-mechanical manner.

Where the apparatus comprises a motor, which may be adapted to directly or intermittently operate the restriction device, the energy transforming device may power the motor with the energy of the second form. Suitably, the restriction device is operable

30 to perform a reversible function and the motor is capable of reversing said function.

In accordance with another embodiment of the invention, the

restriction device comprises a hydraulic restriction device, and the apparatus comprises an implantable pump for operating the hydraulic restriction device, wherein the energy transforming device supplies the energy of the second form for driving the pump. Preferably, the pump is not a plunger type of pump, but may  
5 comprise a peristaltic or membrane pump.

The energy transforming device preferably is capable of generating as the energy of the second form a current exceeding 1  $\mu$ A, when transferring the energy of the first form transmitted  
10 by the energy transmission device.

The apparatus may comprise an implantable adjustment device for adjusting the restriction device to change the restriction of the urine passageway. In accordance with a first alternative the adjustment device is adapted to mechanically adjust the  
15 restriction device. In accordance with a second alternative the adjustment device is adapted to hydraulically adjust the restriction device by using implanted hydraulic means. Such hydraulic means may not use hydraulic fluid of the kind having a viscosity that substantially increases when exposed to heat or  
20 a magnetic field.

The apparatus of the present invention is not limited to the use of visible light for the wireless transmission of energy. Thus, in accordance with a broad aspect of the invention, the energy transmission device transmits energy by at least one  
25 wireless signal, preferably containing radiant energy.

The wireless signal may comprises a wave signal, for example an electromagnetic wave signal, such as an infrared light signal, a visible light signal, an ultra violet light signal, a laser signal, a micro wave signal, a radio wave signal, an x-ray  
30 radiation signal, and a gamma radiation signal. Where applicable, one or more of the above signals may be combined. Alternatively, the wave signal may comprise a sound wave signal, such as an

ultrasonic signal. Generally, the wireless signal may comprise a digital, analog or a digital and analog signal.

The energy of the first form transmitted by the energy transmission device may comprise an electric or magnetic field transmitted in pulses, for example digital pulses. Furthermore, the energy transforming device may transform the energy of the first form, which may comprise polarised energy, into a direct current, pulsating direct current, a combination of a direct and pulsating direct current, an alternating current or a combination of a direct and alternating current. Alternatively, the energy of the first form may comprise kinetic energy.

The energy of the second form may comprise a frequency, amplitude or frequency and amplitude modulated analog, digital or combined analog and digital signal.

The restriction device may be non-inflatable, i.e. with no hydraulic fluid involved for the adjustments of the restriction device. This eliminates problems with fluid leaking from the restriction device.

The apparatus suitably comprises implantable electric conductors connected to the energy transforming device, whereby the energy transforming device is capable of supplying an electric current, such as direct current, a pulsating direct current, a combination of a direct and pulsating direct current, an alternating current or a combination of a direct and alternating current, via the conductors. Furthermore, the energy transforming device may be capable of supplying a frequency, amplitude, or frequency and amplitude modulated analog, digital, or a combination of analog and digital signal, which is used in connection with control of the restriction device.

In accordance with a main embodiment of the invention, the apparatus comprises an implantable operation device for operating the restriction device and a control device for controlling the

operation device, wherein the energy transforming device powers the operation device with the energy of the second form. The operation device preferably comprises a motor, for example an electric linear motor or an electric rotary motor that is controlled by the control device to rotate a desired number of revolutions. Optionally, an implantable gearing may be connected to the motor. The electric motor may have electrically conductive parts made of plastics. Alternatively, the motor may comprise a hydraulic or pneumatic fluid motor, wherein the control device controls the fluid flow through the fluid motor. Motors currently available on the market are getting smaller and smaller. Furthermore, there is a great variety of control methods and miniaturised control equipment available. For example, the number of revolutions of a rotary motor may be analysed by a Hall-element just a few mm in size.

In accordance with another embodiment of the invention, the restriction device comprises hydraulic means and the operation device is adapted to conduct a hydraulic fluid in the hydraulic means. The operation device comprises a fluid conduit connected to the hydraulic means of the restriction device, and a reservoir for fluid, wherein the reservoir forms part of the conduit. The reservoir may form a fluid chamber with a variable volume, and the operation device may be adapted to distribute fluid from the chamber to the hydraulic means of the restriction device by reduction of the volume of the chamber and to withdraw fluid from the hydraulic means to the chamber by expansion of the volume of the chamber. The operation device suitably comprises an implantable motor used for reducing and expanding the volume of the chamber. Also, the operation device may comprise a pump for pumping the hydraulic fluid in the hydraulic means of the restriction device. All of the hydraulic components involved are preferably devoid of any non-return valve. This is of great

advantage, because with valves involved there is always a risk of malfunction due to improperly working valves, especially when long time periods passes between valve operations.

The control device may be adapted to reverse the operation  
5 device by shifting polarity of the energy of the second form. Where the operation device comprises an electric motor the energy of the second form suitably comprises electric energy.

In accordance with yet another embodiment of the invention, the restriction device is operable to perform a reversible  
10 function, such as enlarging and restricting the urine passageway, and there is a reversing device implanted in the patient for reversing the function performed by the restriction device. Such a reversing function preferably involves enlarging and restricting the urine passageway by the restriction device,  
15 suitably in a stepless manner. In this connection, the control device suitably controls the reversing device, which may include a switch, to reverse the function performed by the restriction device. The reversing device may comprise hydraulic means including a valve for shifting the flow direction of a fluid in  
20 the hydraulic means. Alternatively, the reversing device may comprise a mechanical reversing device, such as a switch or a gearbox.

Where the reversing device comprises a switch it may be operable by the energy of the second form. In this case, the  
25 control device suitably controls the operation of the switch by shifting polarity of the energy of the second form supplied to the switch. The switch may comprise an electric switch and the source of energy may supply electric energy for the operation of the switch.

30 In accordance with an advantageous embodiment of the invention, the apparatus further comprises an energy storage device implanted in the patient for storing the energy of the

second form and for supplying energy in connection with the operation of the restriction device. The implanted energy storage device preferably comprises an electric source of energy, such as an accumulator, a rechargeable battery or a combination of an accumulator and rechargeable battery.

The apparatus may further comprise a switch implantable in the patient for switching the operation of the restriction device and a source of energy implantable in the patient. This embodiment is particularly suited for applications where the energy transmission efficiency of the apparatus is insufficient, i.e. where the implanted restriction device is to perform more advanced operations. Such a source of energy preferably is a battery. Alternatively, the source of energy is an accumulator that also may store the energy of the second form.

In accordance with a first alternative, the switch is operated by the energy of the second form supplied by the energy storage device to switch from an off mode, in which the source of energy is not in use, to an on mode, in which the source of energy supplies energy for the operation of the restriction device. In this case, the implanted source of energy may comprise a battery, preferably having a lifetime of at least 10 years, or an accumulator. However, other kinds of sources are also conceivable, such as a nuclear source of energy or a chemical source of energy (fuel cells).

In accordance with a second alternative, the apparatus further comprises a remote control for controlling the supply of energy of the implanted source of energy, wherein the switch is operated by the energy of the second form supplied by the energy storage device to switch from an off mode, in which the remote control is prevented from controlling the source of energy and the source of energy is not in use, to a standby mode, in which the remote control is permitted to control the source of energy

to supply energy for the operation of the restriction device.

In accordance with a third alternative, the energy storage device is omitted, wherein the switch is operated by the energy of the second form supplied by the energy transforming device to  
5 switch from an off mode, in which the remote control is prevented from controlling the source of energy and the source of energy is not in use, to a standby mode, in which the remote control is permitted to control the source of energy to supply energy for the operation of the restriction device.

10 In accordance with a fourth alternative, also the remote control is omitted, wherein the switch is operated by the energy of the second form supplied by the energy transforming device to switch from an off mode, in which the source of energy is not in use, to an on mode, in which the source of energy supplies energy  
15 for the operation of the restriction device. Where applicable, in the described embodiments the switch may switch when the energy transmission device is transmitting wireless energy, preferably while the transferred energy of the second form is stabilised by an implanted capacitor, which may temporarily (for  
20 a few seconds) store the energy of the second form.

In the above noted third and fourth alternatives, the energy transmission device may be substituted for the energy transforming device, whereby the switch is operated by the energy of the first form.

25 The switch mentioned above may comprise an electronic switch or, where applicable, a mechanical switch.

The advantage of using a switch above all is increased control safety; i.e. interfering signals in the patient's surroundings cannot affect the implanted restriction device.  
30 Furthermore, the lifetime of the implanted source of energy will be significantly prolonged, since the energy consumption of the apparatus will be reduced to a minimum. During the above-

mentioned standby mode, the remote control uses energy from the implanted source of energy. By means of the energy transmission device energy may be transmitted to activate the switch to connect the implanted source of energy only when energy is  
5 required in connection with the operation of the restriction device.

All of the above embodiments may be combined with at least one implantable sensor for sensing at least one physical parameter of the patient, wherein the control device may control  
10 the restriction device in response to signals from the sensor. For example, the sensor may comprise a pressure sensor for directly or indirectly sensing the pressure against the restriction device, human tissue or in the urine passageway, or the pressure against the urethra or the lower part of the urine  
15 bladder. The control device may comprise an internal control unit implanted in the patient for, preferably directly, controlling the restriction device in response to signals from the sensor. In response to signals from the sensor, for example pressure, the patient's position or any other important physical parameter, the  
20 internal control unit may send information thereon to outside the patient's body. The control unit may also automatically control the restriction device in response to signals from the sensor. For example, the control unit may control the restriction device to further restrict the urine passageway in response to the  
25 sensor sensing that the patient is lying, or enlarge the urine passageway in response to the sensor sensing an abnormally high pressure against the restriction device.

Alternatively, the control device may comprise an external control unit outside the patient's body for, suitably directly,  
30 controlling the restriction device in response to signals from the sensor. The external control unit may store information on the physical parameter sensed by the sensor and may be manually



operated to control the restriction device based on the stored information. In addition, there may be at least one implantable sender for sending information on the physical parameter sensed by the sensor.

5 An external data communicator may be provided outside the patient's body and an internal data communicator may be implanted in the patient for communicating with the external communicator. The internal communicator may feed data related to the patient, or related to the restriction device, back to the external  
10 communicator. Alternatively or in combination, the external communicator may feed data to the internal communicator. The internal communicator may suitably feed data related to at least one physical signal of the patient.

The apparatus may further comprise an implantable  
15 programmable control unit for controlling the restriction device, preferably over time in accordance with an activity schedule program. This will advance the apparatus and make possible an adaptation of the apparatus to the individual patients.

Many of the above embodiments are suitably remote  
20 controlled. Thus, the apparatus advantageously comprises a wireless remote control transmitting at least one wireless control signal for controlling the restriction device. With such a remote control it will be possible to adapt the function of the apparatus to the patient's need in a daily basis, which is  
25 beneficial with respect to the treatment of the patient. The control signal may comprise a frequency, amplitude or frequency or amplitude modulated signal. Furthermore, the control signal may comprise an analog or a digital signal, or a combination of an analog and digital signal.

30 The wireless remote control may be capable of obtaining information on the condition of the implanted restriction device and of controlling the restriction device in response to the

information. Also, The remote control may be capable of sending information related to the restriction device from inside the patient's body to the outside thereof.

In a particular embodiment of the invention, the wireless remote control comprises at least one external signal transmitter or transceiver and at least one internal signal receiver or transceiver implantable in the patient. In another particular embodiment of the invention, the wireless remote control comprises at least one external signal receiver or transceiver and at least one internal signal transmitter or transceiver implantable in the patient.

The wireless remote control may transmit a carrier signal for carrying the control signal, wherein the carrier signal is frequency, amplitude or frequency and amplitude modulated. The carrier signal may also comprise digital, analog or a combination of digital and analog signals. Such signals may comprise wave signals. Also the control signal used with the carrier signal may be frequency, amplitude or frequency and amplitude modulated, and be digital, analog or combined digital and analog.

The control signal may comprise a wave signal, for example, a sound wave signal, such as an ultrasound wave signal, an electromagnetic wave signal, such as an infrared light signal, a visible light signal, an ultra violet light signal, a laser signal, a micro wave signal, a radio wave signal, an x-ray radiation signal, or a gamma radiation signal. Where applicable, two or more of the above signals may be combined.

The control signal may be digital or analog, and may comprise an electric or magnetic field. Suitably, the wireless remote control may transmit an electromagnetic carrier wave signal for carrying the digital or analog control signal. For example, use of an analog carrier wave signal carrying a digital control signal would give safe communication. The control signal

may be transmitted in pulses by the wireless remote control.

The energy transmission device may function different from or similar to the energy transforming device. For example, the energy transmission and transforming devices function differently  
5 when the energy transmission device comprises a coil used for transmitting the energy of the first form and the energy transforming device comprises an electrical junction element for transforming the transmitted energy into the energy of the second form. The energy transmission and transforming devices function  
10 similar to each other when the energy transmission device comprises a coil used for transmitting the energy of the first form and the energy transforming device also comprises a coil for transforming the transmitted energy into the energy of the second form.

15 In accordance with an alternative embodiment of the invention, the apparatus comprises an activatable source of energy implantable in the patient, wherein the source of energy is activated by wireless energy transmitted by the energy transmission device, to supply energy which is used in connection  
20 with the operation of the restriction device.

The implantable restriction device suitably is embedded in a soft or gel-like material. For example, a silicone material having hardness less than 20 Shore.

25 All the above described various components, such as the motor, pump and capacitor, may be combined in the different embodiments where applicable. Also the various functions described in connection with the above embodiments of the invention may be used in different applications, where applicable.

30 All the various ways of transferring, transforming and controlling energy presented in the present specification may be practised by using all of the various components and solutions

described.

The present invention also provides an implanting method, comprising the steps of providing a urinary incontinence treatment apparatus described above, cutting an opening in a patient's mucosa in an orifice of the patient's body, and  
5 implanting the energy transforming device in the patient's body through the opening.

There is also provided a laparoscopical implanting method, in accordance with a first alternative, comprising the steps of  
10 providing a urinary incontinence treatment apparatus as described above, placing at least two laparoscopic cannula within a patient's body, and implanting the energy transforming device in the patient's body by using the at least two laparoscopic cannula.

In accordance with a second alternative there is provided  
15 a laparoscopic surgical method of implanting a urinary incontinence treatment apparatus, comprising the steps of laparoscopically placing a restriction device of the apparatus through the abdomen or thorax of a patient, placing at least two  
20 laparoscopic trocars within the patient's body, using at least one dissecting tool inserted through the laparoscopic trocar, introducing the restriction device through the trocar, and placing the restriction device in engagement with the urethra or urine bladder to create a restricted urine passageway.

The method may further comprise implanting an energy  
25 transforming device of the apparatus, for example subcutaneously, in the abdomen, thorax or cephalic region, or other locations in the patient's body.

The method may further comprise postoperatively adjusting  
30 the restricted urine passageway in a non-invasive procedure.

The present invention also provides a method of treating a human or animal having chronic urinary incontinence comprising:

(a) Surgically implanting in the human or animal a restriction device engaging the human's or animal's urine bladder or urethra, to form a restricted passageway in the urethra or urine bladder.

(b) Surgically implanting in the human or animal an operation  
5 device, which can adjust the restricted passageway in response to supplied energy. And, (c) in a non-invasive post-operative procedure, from time to time, supplying energy to the operation device so as to enlarge the restricted passageway to allow urine to readily pass through. In the method (c) may be practised  
10 several times (e.g. 2-10) a day.

The invention is described in more detail in the following with reference to the accompanying drawings, in which

FIGURES 1 to 12 are schematic block diagrams illustrating  
15 twelve embodiments, respectively, of the urinary incontinence treatment apparatus of the invention, in which wireless energy is transmitted from outside a patient's body to energy consuming components of the apparatus implanted in the patient.

FIGURE 13 is a schematic block diagram illustrating  
20 conceivable combinations of implanted components for achieving various communication options;

FIGURE 14 illustrates an electrical junction element for use in the apparatus of the present invention; and

FIGURE 15 illustrates the apparatus in accordance with the  
25 invention implanted in a patient;

FIGURE 16 is a block diagram illustrating remote control components of an embodiment of the invention, in which wireless energy is transmitted by the use of electromagnetic signals; and

FIGURE 17 is a schematic view of exemplary circuitry used  
30 for the components of the block diagram of FIGURE 16.

Referring to the drawing figures, like reference numerals designate identical or corresponding elements throughout the

several figures.

FIGURE 1 schematically shows a most simple embodiment of the urine incontinence disease apparatus of the invention having some parts implanted in a patient and other parts located outside the patient's body. Thus, in FIGURE 1 all parts placed to the right of the patient's skin 2 are implanted and all parts placed to the left of the skin 2 are located outside the patient's body.

The apparatus of FIGURE 1 comprises an implanted operable restriction device 4, which engages the patient's urethra (or alternatively engages the urine bladder) to form a restricted urine passageway in the urethra. The restriction device 4 is capable of performing a reversible function, i.e. to enlarge and reduce the cross-sectional area of the urine passageway, whereby the restriction device 4 works as an artificial sphincter. An implanted energy transforming device 6 is adapted to supply energy consuming components of the restriction device 4 with energy via a power supply line 12. An external energy transmission device 10 includes a wireless remote control for transmitting a wireless signal, which is received by a signal receiver incorporated in the implanted energy transforming device 6. The implanted energy transforming device 6 transforms energy from the signal into electric energy that is supplied via the power supply line 12.

FIGURE 2 shows an embodiment of the invention identical to that of FIGURE 1, except that a reversing device in the form of an electric switch 14 energy also is implanted in the patient for reversing the restriction device 4. The wireless remote control of the external energy transmission device 10 transmits a wireless signal that carries energy and the implanted energy transforming device 6 transforms the wireless energy into a current for operating the switch 14. When the polarity of the

current is shifted by the energy transforming device 6 the switch 14 reverses the function performed by the restriction device 4.

FIGURE 3 shows an embodiment of the invention identical to that of FIGURE 1, except that an operation device in the form of a motor 15 for operating the restriction device 4 also is implanted in the patient. The motor 15 is powered with energy from the energy transforming device 6, as the remote control of the external energy transmission device 10 transmits a wireless signal to the receiver of the energy transforming device 6.

FIGURE 4 shows an embodiment of the invention identical to that of FIGURE 1, except that an assembly 16 including a motor/pump unit 18 and a fluid reservoir 20 also is implanted in the patient. In this case the restriction device 4 is hydraulically operated, i.e. hydraulic fluid is pumped by the motor/pump unit 18 from the reservoir 20 through a conduit 22 to the restriction device 4 to reduce the cross-sectional area of the urine passageway, and hydraulic fluid is pumped by the motor/pump unit 18 back from the restriction device 4 to the reservoir 20 to enlarge the cross-sectional area. The implanted energy transforming device unit 6 transforms wireless energy into a current, for example a current, for powering the motor/pump unit 18 via an electric power supply line 24.

FIGURE 5 shows an embodiment of the invention comprising the external energy transmission device 10 with its wireless remote control, the restriction device 4, in this case hydraulically operated, and the implanted energy transforming device 6, and further comprising an implanted hydraulic fluid reservoir 30, an implanted motor/pump unit 32 and an implanted reversing device in the form of a hydraulic valve shifting device 34. The motor of the motor/pump unit 32 is an electric motor. In response to a control signal from the wireless remote control of the external energy transmission device 10, the implanted energy transforming

device 6 powers the motor/pump unit 32 with energy from the energy carried by the control signal, whereby the motor/pump unit 32 distributes hydraulic fluid between the reservoir 30 and the restriction device 4. The remote control of the energy transmission device 10 controls the shifting device 34 to shift the hydraulic fluid flow direction between one direction in which the fluid is pumped by the motor/pump unit 32 from the reservoir 30 to the restriction device 4 to reduce the cross-sectional area of the urine passageway, and another opposite direction in which the fluid is pumped by the motor/pump unit 32 back from the restriction device 4 to the reservoir 30 to enlarge the cross-sectional area.

FIGURE 6 shows an embodiment of the invention identical to that of FIGURE 1, except that a control unit 36 controlled by the wireless remote control of the external energy transmission device 10, an accumulator 38 and a capacitor 40 also are implanted in the patient. The control unit 36 stores electric energy received from the energy transforming device 6 in the accumulator 38, which supplies energy to the restriction device 4. In response to a control signal from the wireless remote control of the energy transmission device 10, the control unit 6 either releases electric energy from the accumulator 38 and transfers the released energy via power lines 42 and 44, or directly transfers electric energy from the energy transforming device 6 via a power line 46, the capacitor 40, which stabilises the electric current, a power line 48 and the power line 44, for the operation of the restriction device 4.

In accordance with one alternative, the capacitor 40 in the embodiment of FIGURE 6 may be omitted. In accordance with another alternative, the accumulator 38 in this embodiment may be omitted.

FIGURE 7 shows an embodiment of the invention identical to



that of FIGURE 1, except that a battery 50 for supplying energy for the operation of the restriction device 4 and an electric switch 52 for switching the operation of the restriction device 4 also are implanted in the patient. The switch 52 is operated  
5 by the energy supplied by the energy transforming device 6 to switch from an off mode, in which the battery 50 is not in use, to an on mode, in which the battery 50 supplies energy for the operation of the restriction device 4.

FIGURE 8 shows an embodiment of the invention identical to  
10 that of FIGURE 7, except that a control unit 36 controllable by the wireless remote control of the external energy transmission device 10 also is implanted in the patient. In this case, the switch 52 is operated by the energy supplied by the energy transforming device 6 to switch from an off mode, in which the  
15 wireless remote control is prevented from controlling the control unit 36 and the battery is not in use, to a standby mode, in which the remote control is permitted to control the control unit 36 to release electric energy from the battery 50 for the operation of the restriction device 4.

20 FIGURE 9 shows an embodiment of the invention identical to that of FIGURE 8, except that an accumulator 38 is substituted for the battery 50 and the implanted components are interconnected differently. In this case, the accumulator 38 stores energy from the energy transforming device 6. In response  
25 to a control signal from the wireless remote control of the external energy transmission device 10, the implanted control unit 36 controls the switch 52 to switch from an off mode, in which the accumulator 38 is not in use, to an on mode, in which the accumulator 38 supplies energy for the operation of the  
30 restriction device 4.

FIGURE 10 shows an embodiment of the invention identical to that of FIGURE 9, except that a battery 50 also is implanted in

the patient and the implanted components are interconnected differently. In response to a control signal from the wireless remote control of the external energy transmission device 10, the implanted control unit 36 controls the accumulator 38 to deliver  
5 energy for operating the switch 52 to switch from an off mode, in which the battery 50 is not in use, to an on mode, in which the battery 50 supplies electric energy for the operation of the restriction device 4.

Alternatively, the switch 52 may be operated by energy  
10 supplied by the accumulator 38 to switch from an off mode, in which the wireless remote control is prevented from controlling the battery 50 to supply electric energy and is not in use, to a standby mode, in which the wireless remote control is permitted to control the battery 50 to supply electric energy for the  
15 operation of the restriction device 4.

FIGURE 11 shows an embodiment of the invention identical to that of FIGURE 7, except that a motor 15, a mechanical reversing device in the form of a gearbox 54 and a control unit 36 for controlling the gearbox 54 also are implanted in the patient. The  
20 implanted control unit 36 controls the gearbox 54 to reverse the function performed by the restriction device 4 (mechanically operated).

FIGURE 12 shows an embodiment of the invention identical to that of FIGURE 10 except that the implanted components are  
25 interconnected differently. Thus, in this case the battery 50 powers the control unit 36 when the accumulator 38, suitably a capacitor, activates the switch 52 to switch to an on mode. When the switch 52 is in its on mode the control unit 36 is permitted to control the battery 50 to supply, or not supply, energy for  
30 the operation of the restriction device 4.

FIGURE 13 schematically shows conceivable combinations of implanted components of the apparatus for achieving various

communication options. Basically, there are the implanted restriction device 4, control unit 36 and motor/pump unit 18, and the external energy transmission device 10 including the external wireless remote control. As already described above the wireless remote control transmits a control signal which is received by the implanted control unit 36, which in turn controls the various implanted components of the apparatus.

A sensor 56 may be implanted in the patient for sensing a physical parameter of the patient, such as the pressure in the urine passageway. The implanted control unit 36, or alternatively the external wireless remote control of the energy transmission device 10, may control the restriction device 4 in response to signals from the sensor 56. A transceiver may be combined with the sensor 56 for sending information on the sensed physical parameter to the external wireless remote control. The wireless remote control may comprise a signal transmitter or transceiver and the implanted control unit 36 may comprise a signal receiver or transceiver. Alternatively, the wireless remote control may comprise a signal receiver or transceiver and the implanted control unit 36 may comprise a signal transmitter or transceiver. The above transceivers, transmitters and receivers may be used for sending information or data related to the restriction device 4 from inside the patient's body to the outside thereof.

Where the motor/pump unit 18 and battery 50 for powering the motor/pump unit 18 are implanted, the battery 50 may be equipped with a transceiver for sending information on the condition of the battery 50.

Those skilled in the art will realise that the above various embodiments according to FIGURES 1-13 could be combined in many different ways. For example, the energy operated switch 14 could be incorporated in any of the embodiments of FIGURES 3,6-12, the hydraulic shifting device 34 could be incorporated in the

embodiment of FIGURE 4, and the gearbox 54 could be incorporated in the embodiment of FIGURE 3.

FIGURE 14 shows an energy transforming device in the form of an electrical junction element 58 for use in any of the above 5 embodiments according to FIGURES 1-13. The element 58 is a flat p-n junction element comprising a p-type semiconductor layer 60 and an n-type semiconductor layer 62 sandwiched together. A light bulb 64 is electrically connected to opposite sides of the element 58 to illustrate how the generated current is obtained. 10 The output of current from such a p-n junction element 58 is correlated to the temperature. See the formula below.

$$I = I_0 (\exp.(qV/kT) - 1)$$

15 where

I is the external current flow,

I<sub>0</sub> is the reverse saturation current,

q is the fundamental electronic charge of 1.602 x 10<sup>-19</sup> coulombs,

20 V is the applied voltage,

k is the Boltzmann constant, and

T is the absolute temperature.

Under large negative applied voltage (reverse bias), the 25 exponential term becomes negligible compared to 1.0, and I is approximately -I<sub>0</sub>. I<sub>0</sub> is strongly dependent on the temperature of the junction and hence on the intrinsic-carrier concentration. I<sub>0</sub> is larger for materials with smaller bandgaps than for those with larger bandgaps. The rectifier action of the diode - that 30 is, its restriction of current flow to only one direction - is in this particular embodiment the key to the operation of the p-n junction element 58.

An alternative way to design a p-n junction element is to deposit a thin layer of semiconductor onto a supporting material which does not absorb the kind of energy utilised in the respective embodiments. For use with wirelessly transmitted energy in terms of light waves, glass could be a suitable material. Various materials may be used in the semiconductor layers such as but not limited to cadmium telluride, copper-indium-diselenide and silicon. It is also possible to use a multilayer structure with several layers of p and n-type materials to improve efficiency.

The electric energy generated by the p-n junction element 58 could be of the same type as generated by solar cells, in which the negative and positive fields create a direct current. Alternatively, the negative and positive semiconductor layers may change polarity following the transmitted waves, thereby generating an alternating current.

The p-n junction element 58 is designed to make it suited for implantation. Thus, all the external surfaces of the element 58 in contact with the human body are made of a biocompatible material. The p-n junction semiconductors are designed to operate optimally at a body temperature of 37° C because the current output, which should be more than 1  $\mu$ A, is significantly depending on temperature as shown above. Since both the skin and subcutis absorb energy, the relation between the sensitivity or working area of the element 58 and the intensity or strength of the wireless energy transmission is considered. The p-n junction element 58 preferably is designed flat and small. Alternatively, if the element 58 is made in larger sizes it should be flexible, in order to adapt to the patient's body movements. The volume of the element 58 should be kept less than 2000 cm<sup>3</sup>.

FIGURE 15 generally illustrates how any of the above-described embodiments of the urine incontinence disease treatment

apparatus of the invention may be implanted in a patient. Thus, a restriction device 4 implanted in a patient engages the urethra 66 to form an artificial sphincter around the urine passageway in the urethra 66. An implanted operation device 68, such as an electric motor or a motor/pump assembly, operates the restriction device 4 through a transmission member 70, such as a mechanical transmission cord or a fluid tube. An energy transforming device in the form of an element 6 having a positive region and a negative region, as described above in more detail, is placed underneath the skin of the patient.

Wireless energy carried by a signal transmitted by a wireless remote control of an external energy transmission device 10 at least partly penetrates the patient's skin and hits the element 6. The energy thus hitting the element 6 is transformed into energy of a different form that is suited for powering the operation device 68. For example, where the operation device 68 is an electric motor the element 6 comprises an electric p-n junction element that transforms the wireless energy into an electric current for powering the electric motor. Where the operation device 68 comprises a pump, the element 6 may transform the wireless energy into kinetic energy for powering the pump.

The transformed energy may be utilised for directly operating the restriction device 4 or, where the restriction device 4 is electrically operated, for storage in a capacitor and/or an accumulator for later or parallel use. Preferably (but not necessarily) the element 6 is controlled by a microprocessor. The wireless remote control of the external energy transmission device 10 is used to control the utilisation of the transmitted energy and any function or command to/from the implanted restriction device 4.

FIGURE 16 shows the basic parts of a wireless remote control of the apparatus of the invention including an electric motor 128

for operating a restriction member, for example of the type illustrated in FIGURE 15. In this case, the remote control is based on the transmission of electromagnetic wave signals, often of high frequencies in the order of 100 kHz - 1 GHz, through the skin 130 of the patient. In FIGURE 15, all parts placed to the left of the skin 130 are located outside the patient's body and all parts placed to the right of the skin 130 are implanted. Any suitable remote control system may be used.

An external signal transmitting antenna 132 is to be positioned close to a signal receiving antenna 134 implanted close to the skin 130. As an alternative, the receiving antenna 134 may be placed for example inside the abdomen of the patient. The receiving antenna 134 comprises a coil, approximately 1-100 mm, preferably 25 mm in diameter, wound with a very thin wire and tuned with a capacitor to a specific high frequency. A small coil is chosen if it is to be implanted under the skin of the patient and a large coil is chosen if it is to be implanted in the abdomen of the patient. The transmitting antenna 132 comprises a coil having about the same size as the coil of the receiving antenna 134 but wound with a thick wire that can handle the larger currents that is necessary. The coil of the transmitting antenna 132 is tuned to the same specific high frequency as the coil of the receiving antenna 134.

An external control unit 136 comprises a microprocessor, a high frequency electromagnetic wave signal generator and a power amplifier. The microprocessor of the control unit 136 is adapted to switch the generator on/off and to modulate signals generated by the generator to send digital information via the power amplifier and the antennas 132,134 to an implanted control unit 138. To avoid that accidental random high frequency fields trigger control commands, digital signal codes are used. A conventional keypad placed on the external control unit 136 is

connected to the microprocessor thereof. The keypad is used to order the microprocessor to send digital signals to either contract or enlarge the restriction device. The microprocessor starts a command by applying a high frequency signal on the antenna 132. After a short time, when the signal has energised the implanted parts of the control system, commands are sent to contract or enlarge the restriction device in predefined steps. The commands are sent as digital packets in the form illustrated below.

10

Start pattern, 8 bits	Command, 8 bits	Count, 8 bits	Checksum, 8 bits
--------------------------	--------------------	------------------	---------------------

The commands are sent continuously during a rather long time period (e.g. about 30 seconds or more). When a new contract or enlarge step is desired the Count byte is increased by one to allow the implanted control unit 138 to decode and understand that another step is demanded by the external control unit 136. If any part of the digital packet is erroneous, its content is simply ignored.

Through a line 140, an implanted energiser unit 126 draws energy from the high frequency electromagnetic wave signals received by the receiving antenna 134. The energiser unit 126 stores the energy in an energy storage device, such as a large capacitor, powers the control unit 138 and powers the electric motor 128 via a line 142.

The control unit 138 comprises a demodulator and a microprocessor. The demodulator demodulates digital signals sent from the external control unit 136. The microprocessor of the control unit 138 receives the digital packet, decodes it and, provided that the power supply of the energiser unit 126 has



sufficient energy stored, sends a signal via a signal line 144 to the motor 128 to either contract or enlarge the restriction device depending on the received command code.

Alternatively, the energy stored in the energy storage  
5 device of the energiser unit may only be used for powering a switch, and the energy for powering the motor 128 may be obtained from another implanted energy source of relatively high capacity, for example a battery. In this case the switch is adapted to connect said battery to the control unit 138 in an on mode when  
10 said switch is powered by the energy storage device and to keep the battery disconnected from the control unit in a standby mode when the switch is not powered.

With reference to FIGURE 17, the remote control schematically described above will now be described in accordance  
15 with a more detailed embodiment. The external control unit 136 comprises a microprocessor 146, a signal generator 148 and a power amplifier 150 connected thereto. The microprocessor 146 is adapted to switch the signal generator 148 on/off and to modulate signals generated by the signal generator 148 with digital  
20 commands that are sent to implanted components of the apparatus. The power amplifier 150 amplifies the signals and sends them to the external signal transmitting antenna 132. The antenna 132 is connected in parallel with a capacitor 152 to form a resonant circuit tuned to the frequency generated by the signal generator  
25 148.

The implanted signal receiving antenna coil 134 forms together with a capacitor 154 a resonant circuit that is tuned to the same frequency as the transmitting antenna 132. The signal receiving antenna coil 134 induces a current from the received  
30 high frequency electromagnetic waves and a rectifying diode 160 rectifies the induced current, which charges a storage capacitor 158. A coil 156 connected between the antenna coil 134 and the

diode 160 prevents the capacitor 158 and the diode 160 from loading the circuit of the signal receiving antenna 134 at higher frequencies. Thus, the coil 156 makes it possible to charge the capacitor 158 and to transmit digital information using amplitude modulation.

A capacitor 162 and a resistor 164 connected in parallel and a diode 166 forms a detector used to detect amplitude modulated digital information. A filter circuit is formed by a resistor 168 connected in series with a resistor 170 connected in series with a capacitor 172 connected in series with the resistor 168 via ground, and a capacitor 174, one terminal of which is connected between the resistors 168,170 and the other terminal of which is connected between the diode 166 and the circuit formed by the capacitor 162 and resistor 164. The filter circuit is used to filter out undesired low and high frequencies. The detected and filtered signals are fed to an implanted microprocessor 176 that decodes the digital information and controls the motor 128 via an H-bridge 178 comprising transistors 180,182,184 and 186. The motor 128 can be driven in two opposite directions by the H-bridge 178.

The microprocessor 176 also monitors the amount of stored energy in the storage capacitor 158. Before sending signals to activate the motor 128, the microprocessor 176 checks whether the energy stored in the storage capacitor 158 is enough. If the stored energy is not enough to perform the requested operation, the microprocessor 176 waits for the received signals to charge the storage capacitor 158 before activating the motor 128.

CLAIMS

1. A urinary incontinence treatment apparatus, comprising a restriction device implantable in a patient, who suffers from urinary incontinence, for engaging the urethra or urine bladder, to form a restricted urine passageway in the urethra or urine bladder, the restriction device being operable to change the restriction of the urine passageway, **characterised** by an energy transmission device for wireless transmission of energy from outside the patient's body to inside the patient's body for use in connection with the operation of the restriction device including enlarging or restricting the urine passageway, when the restriction device is implanted.

2. An apparatus according to claim 1, wherein the energy transmission device transmits energy of a first form and the restriction device is operable in response to energy of a second form, and further comprising an energy transforming device implantable in the patient for transforming the energy of the first form wirelessly transmitted by the energy transmission device into the energy of the second form.

3. An apparatus according to claim 2, wherein the energy of the second form is different than the energy of the first form.

4. An apparatus according to claim 2 or 3, wherein the energy transforming device comprises at least one element having a positive region and a negative region, the element is capable of creating an energy field between the positive and negative regions when exposed to the energy of the first form transmitted by the energy transmission device, and the energy field produces

the energy of the second form.

5           5. An apparatus according to claim 4, wherein the element comprises an electrical junction element, and the electrical junction element is capable of inducing an electric field between the positive and negative regions when exposed to the energy of the first form transmitted by the energy transmission device, whereby the energy of the second form comprises electric energy.

10           6. An apparatus according to claim 5, wherein the restriction device is electrically operated, and the positive and negative regions of the electrical junction element supply electric energy for the operation of the restriction device.

15           7. An apparatus according to claim 6, further comprising electric conductors connected to the positive and negative regions of the electrical junction element, whereby the electrical junction element is capable of supplying an electric current via the conductors.

20

          8. An apparatus according to claim 7, wherein the electrical junction element is capable of supplying a direct current or pulsating direct current via the conductors.

25           9. An apparatus according to claim 7, wherein the electrical junction element is capable of supplying an alternating current or a combination of a direct and alternating current via the conductors.

30           10. An apparatus according to claim 6, wherein the electrical junction element is capable of supplying a frequency or amplitude modulated signal.

11. An apparatus according to claim 6, wherein the electrical junction element is capable of supplying an analog or digital signal.

5

12. An apparatus according to any of claims 2-11, wherein the energy transforming device forms a flat and thin sheet, and has a volume of less than 2000 cm<sup>3</sup>.

10

13. An apparatus according to claim 2 or 3, wherein the energy transforming device is adapted to transform the energy of the first form directly or indirectly into the energy of the second form.

15

14. An apparatus according to claim 13, further comprising an implantable motor or pump for operating the restriction device, wherein the motor or pump is powered by the energy of the second form.

20

15. An apparatus according to claim 14, wherein the energy transforming device is adapted to directly power the motor or pump by the transformed energy, as the energy of the second form is being transformed from the energy of the first form.

25

16. An apparatus according to any of claims 13-15, wherein the wireless energy of the first form comprises sound waves and the energy of the second form comprises electric energy.

30

17. An apparatus according to any of claims 2-16, wherein the energy transforming device comprises a capacitor and the energy of the second form comprises electric energy.

18. An apparatus according to claim 17, wherein the capacitor is adapted to produce electric pulses from the transformed electric energy.

5

19. An apparatus according to claim 18, wherein the capacitor is adapted to produce the pulses of the electric energy, as the energy transforming device transforms the energy of the first form transmitted by the energy transmission device into the electric energy of the second form.

10

20. An apparatus according to claim 2, further comprising an implantable stabiliser for stabilising the energy of the second form.

15

21. An apparatus according to claim 20, wherein the energy of the second form comprises electric current and the stabiliser comprises at least one capacitor.

20

22. An apparatus according to any of the preceding claims, further comprising implantable electrical components including at least one voltage level guard.

25

23. An apparatus according to any of claims 1-21, further comprising implantable electrical components including a single voltage level guard.

30

24. An apparatus according to claim 22 or 23, wherein the electrical components are devoid of any current detector and/or charge level detector.

25. An apparatus according to any of claims 22-24, further

comprising an implantable capacitor or accumulator, wherein the charge or discharge of the capacitor or accumulator is controlled by use of the voltage level guard.

5           26. An apparatus according to any of claims 17-19,21 and 25, wherein the capacitor has a capacity less than 0,1  $\mu$ F.

          27. An apparatus according to claim 1, wherein the energy transmission device is adapted to transmit wireless energy for  
10 direct use in connection with the operation of the restriction device, as the wireless energy is being transmitted.

          28. An apparatus according to claim 27, further comprising an implantable motor or pump for operating the restriction  
15 device, wherein the energy transmission device is adapted to directly power the motor or pump with wireless energy.

          29. An apparatus according to claim 28, wherein the energy transmission device is adapted to transmit wireless energy in the  
20 form of a magnetic field or electromagnetic waves for direct power of the motor or pump

          30. An apparatus according to claim 2, wherein the energy transforming device is adapted to supply the energy of the second  
25 form for direct use in connection with the operation of the restriction device, as the energy of the first form is being transformed into the energy of the second form.

          31. An apparatus according to claim 30, further comprising  
30 an implantable motor or pump for operating the restriction device, wherein the energy transforming device is adapted to directly power the motor or pump with the energy of the second

form.

32. An apparatus according to claim 31, wherein the energy transforming device directly operates the restriction device with the energy of the second form in a non-magnetic, non-thermal or non-mechanical manner.

33. An apparatus according to any of claims 2-12, further comprising an implantable motor for direct or intermittent operation of the restriction device, wherein the energy transforming device powers the motor with the energy of the second form.

34. An apparatus according to claim 33, wherein the restriction device is operable to perform a reversible function and the motor is capable of reversing said function.

35. An apparatus according to any of claims 2-27 and 30, wherein the restriction device comprises a hydraulic restriction device, and further comprising an implantable pump for operating the hydraulic restriction device, the energy transforming device supplying the energy of the second form for driving the pump.

36. An apparatus according to any of claims 28,29,31 and 35, wherein the pump is not a plunger type of pump.

37. An apparatus according to any of the preceding claims, wherein the energy transforming device is capable of generating as the energy of the second form a current exceeding 1  $\mu$ A, when transferring the energy of the first form transmitted by the energy transmission device.



38. An apparatus according to any of the preceding claims, further comprising an adjustment device for adjusting the restriction device to change the restriction of the urine passageway, wherein the adjustment device is adapted to mechanically adjust the restriction device, or adapted to hydraulically adjust the restriction device by using hydraulic means which is devoid of hydraulic fluid of the kind having a viscosity that substantially increases when exposed to heat or a magnetic field.

39. An apparatus according to any of claims 2-12, wherein the energy transforming device comprises at least one semiconductor type of component.

15

40. An apparatus according to claim 39, wherein the energy transforming device comprises a circuitry of semiconductor components.

41. An apparatus according to claim 39, wherein the semiconductor component comprises a transistor or microchip or similar electronic components excluding rectifying diodes.

42. An apparatus according to claim 40 or 41, wherein the semiconductor component comprises at least one element having a positive region and a negative region, the element is capable of creating an energy field between the positive and negative regions when exposed to the energy of the first form transmitted by the energy transmission device, and the energy field produces the energy of the second form.

30

43. An apparatus according to any of the preceding claims,

further comprising an implantable operation device for operating the restriction device, wherein the energy transforming device powers the operation device with the energy of the second form.

5           44. An apparatus according to claim 43, further comprising a control device for controlling the operation device.

          45. An apparatus according to claim 43 or 44, wherein the operation device comprises a motor.

10

          46. An apparatus according to claim 33 or 45, further comprising an implantable gearing connected to the motor.

          47. An apparatus according to claims 44 and 45, wherein the  
15 motor comprises a rotary motor and the control device controls the rotary motor to rotate a desired number of revolutions.

          48. An apparatus according to claim 45, wherein the motor comprises a linear motor.

20

          49. An apparatus according to claim 44 and 45, wherein the motor comprises a hydraulic or pneumatic fluid motor, and the control device controls the fluid motor.

25           50. An apparatus according to claim 45, wherein the motor comprises an electric motor having electrically conductive parts made of plastics.

          51. An apparatus according to claim 43, wherein the  
30 restriction device comprises hydraulic means and the operation device is adapted to conduct a hydraulic fluid in the hydraulic means.

52. An apparatus according to claim 51, wherein the operation device comprises a fluid conduit connected to the hydraulic means of the restriction device, and a reservoir for  
5 fluid, the reservoir forming part of the conduit.

53. An apparatus according to claim 52, wherein the hydraulic means and conduit are devoid of any non-return valve.

10 54. An apparatus according to claim 53, wherein the reservoir forms a fluid chamber with a variable volume, and the operation device is adapted to distribute fluid from the chamber to the hydraulic means of the restriction device by reduction of the volume of the chamber and to withdraw fluid from the  
15 hydraulic means to the chamber by expansion of the volume of the chamber.

55. An apparatus according to claim 54, wherein the operation device comprises an implantable motor used for reducing  
20 and expanding the volume of the chamber.

56. An apparatus according to any of claims 51-53, wherein the operation device comprises an implantable pump for pumping the hydraulic fluid in the hydraulic means of the restriction  
25 device.

57. An apparatus according to claim 44, wherein the control device shifts polarity of the energy of the second form to reverse the operation device.

30

58. An apparatus according to claim 45 or 57, wherein the operation device comprises an electric motor and the energy of

the second form comprises electric energy.

59. An apparatus according to any of claims 1, 43 and 44,  
wherein the restriction device is operable to perform a  
5 reversible function.

60. An apparatus according to claim 59, further comprising  
a reversing device implantable in the patient for reversing the  
function performed by the restriction device.

10

61. An apparatus according to claims 44 and 60, wherein the  
control device controls the reversing device to reverse the  
function performed by the restriction device.

15

62. An apparatus according to claim 60 or 61, wherein the  
reversing device comprises hydraulic means including a valve for  
shifting the flow direction of a fluid flow in the hydraulic  
means.

20

63. An apparatus according to claim 60 or 61, wherein the  
reversing device comprises a mechanical reversing device.

25

64. An apparatus according to claim 63, wherein the  
reversing device comprises a gearbox.

65. An apparatus according to claim 60 or 61, wherein the  
reversing device comprises a switch.

66. An apparatus according to claim 65, wherein the switch  
30 is operable by the energy of the second form.

67. An apparatus according to claim 66, wherein the control

device controls the operation of the switch by shifting polarity of the energy of the second form.

5 68. An apparatus according to claim 66 or 67, wherein the switch comprises an electric switch and the energy of the second form comprises electric energy.

10 69. An apparatus according to claim 43, wherein the operation device comprises hydraulic means and at least one valve for controlling a fluid flow in the hydraulic means.

70. An apparatus according to claim 69, further comprising a wireless remote control for controlling the valve.

15 71. An apparatus according to any one of claims 18, 19 and 44, wherein the control device is adapted to control the energy transforming device to produce the energy of the second form in a train of energy pulses for direct use in connection with the operation of the restriction device.

20

72. An apparatus according to claim 2, further comprising an energy storage device implantable in the patient for storing the energy of the second form and for supplying energy in connection with the operation of the restriction device.

25

73. An apparatus according to claim 72, wherein the energy storage device comprises an accumulator.

30 74. An apparatus according to claim 73, wherein the energy of the second form comprises electric energy and the energy storage device comprises an electric accumulator.

75. An apparatus according to claim 74, wherein the electric accumulator comprises at least one capacitor or at least one rechargeable battery, or a combination of at least one capacitor and at least one rechargeable battery.

5

76. An apparatus according to any of claims 2,65,71-75, further comprising a switch implantable in the patient for directly or indirectly switching the operation of the restriction device.

10

77. An apparatus according to claim 76, further comprising a source of energy implantable in the patient, wherein the switch is operated by the energy of the second form supplied by the energy storage device to switch from an off mode, in which the source of energy is not in use, to an on mode, in which the source of energy supplies energy for the operation of the restriction device.

78. An apparatus according to claim 76, further comprising a source of energy implantable in the patient, and a remote control for controlling the supply of energy of the source of energy, wherein the switch is operated by the energy of the second form supplied by the energy storage device to switch from an off mode, in which the remote control is prevented from controlling the source of energy and the source of energy is not in use, to a standby mode, in which the remote control is permitted to control the source of energy to supply energy for the operation of the restriction device.

79. An apparatus according to claim 76, further comprising a source of energy implantable in the patient for supplying energy for the operation of the restriction device, wherein the

30

switch is operated by the energy of the second form supplied by the energy transforming device to switch from an off mode, in which the source of energy is not in use, to an on mode, in which the source of energy supplies energy for the operation of the  
5 restriction device.

80. An apparatus according to claim 76, further comprising a source of energy implantable in the patient for supplying energy for the operation of the restriction device, and a remote  
10 control for controlling the supply of energy of the implantable source of energy, wherein the switch is operated by the energy of the second form supplied by the energy transforming device to switch from an off mode, in which the remote control is prevented from controlling the source of energy and the source of energy  
15 is not in use, to a standby mode, in which the remote control is permitted to control the source of energy to supply energy for the operation of the restriction device.

81. An apparatus according to claim 76, further comprising  
20 a source of energy implantable in the patient for supplying energy for the operation of the restriction device, wherein the switch is operated by the energy of the first form supplied by the energy transmission device to switch from an off mode, in which the source of energy is not in use, to an on mode, in which  
25 the source of energy supplies energy for the operation of the restriction device.

82. An apparatus according to claim 76, further comprising a source of energy implantable in the patient for supplying  
30 energy for the operation of the restriction device, and a remote control for controlling the supply of energy of the implantable source of energy, wherein the switch is operated by the energy

of the first form supplied by the energy transmission device to switch from an off mode, in which the remote control is prevented from controlling the source of energy and the source of energy is not in use, to a standby mode, in which the remote control is permitted to control the source of energy to supply energy for the operation of the restriction device.

83. An apparatus according to claim 2, wherein the restriction device is electrically operated, and the energy of the second form comprises electric energy.

84. An apparatus according to claim 83, further comprising electric conductors connected to the energy transforming device, whereby the energy transforming device is capable of supplying an electric current via the conductors.

85. An apparatus according to claim 2, wherein the energy transforming device is capable of supplying a frequency, amplitude or frequency and amplitude modulated signal.

86. An apparatus according to claim 2, wherein the energy transforming device is capable of supplying an analog, digital or a combination of an analog and digital signal.

87. An apparatus according to claim 1, further comprising an activatable source of energy implantable in the patient, wherein the source of energy is activated by wireless energy transmitted by the energy transmission device, to supply energy which is used in connection with the operation of the restriction device.

88. An apparatus according to claim 1, wherein the energy



transmission device transmits energy by at least one wireless signal.

89. An apparatus according to claim 88, wherein the signal  
5 contains radiant energy.

90. An apparatus according to claim 88, wherein the signal  
comprises a wave signal.

10 91. An apparatus according to claim 90, wherein the wave  
signal comprises an electromagnetic wave signal including one of  
an infrared light signal, a visible light signal, an ultra violet  
light signal, a laser signal, a micro wave signal, a radio wave  
signal, an x-ray radiation signal, and a gamma radiation signal.

15

92. An apparatus according to claim 90, wherein the wave  
signal comprises a sound or ultrasound wave signal.

93. An apparatus according to any one of claims 88-92,  
20 wherein the signal comprises a digital or analog signal, or a  
combination of a digital and analog signal.

94. An apparatus according to claim 2, wherein the energy  
of the first form transmitted by the energy transmission device  
25 comprises an electric, an electromagnetic or a magnetic field,  
or a combination thereof.

95. An apparatus according to claim 94, wherein the  
electric, electromagnetic or magnetic field, or the combination  
30 thereof is transmitted in pulses or digital pulses, or a  
combination of pulses and digital pulses by the energy  
transmission device.

96. An apparatus according to claim 2, wherein the energy of a first form transmitted by the energy transmission device comprises an electric, an electromagnetic or a magnetic field, or a combination thereof.

97. An apparatus according to claim 96, wherein the electric, electromagnetic or magnetic field, or the combination thereof is transmitted in waves or analog pulses or a combination thereof by the energy transmission device.

98. An apparatus according to any one of claims 1-97, wherein the energy transmitted by the energy transmission device comprises polarised energy.

99. An apparatus according to claim 2, wherein the energy transforming device transforms the energy of the first form into a direct current or pulsating direct current, or a combination of a direct current and pulsating direct current.

100. An apparatus according to claim 2, wherein the energy transforming device transforms the energy of the first form into an alternating current or a combination of a direct and alternating current.

101. An apparatus according to claim 2, further comprising an implantable pulse generator for generating electrical pulses from the energy of the second form produced by the energy field.

102. An apparatus according to any one of the preceding claims, further comprising at least one implantable sensor for sensing at least one physical parameter of the patient.

103. An apparatus according to claim 102, wherein the sensor comprises a pressure sensor for directly or indirectly sensing as the physical parameter the pressure in the urine passageway or the pressure against the urethra or the lower part of the urine bladder.

104. An apparatus according to claim 102, further comprising a control device for controlling the restriction device in response to signals from the sensor.

105. An apparatus according to claim 104, wherein the control device comprises an internal control unit implantable in the patient for controlling the restriction device in response to signals from the sensor.

106. An apparatus according to claim 105, wherein the internal control unit directly controls the restriction device in response to signals from the sensor.

107. An apparatus according to claim 104, wherein the control device comprises an external control unit outside the patient's body for controlling the restriction device in response to signals from the sensor.

108. An apparatus according to claim 107, wherein the external control unit stores information on the physical parameter sensed by the sensor and is manually operated to control the restriction device based on the stored information.

109. An apparatus according to any one of claims 102-108, further comprising at least one implantable sender for sending

information on the physical parameter sensed by the sensor.

110. An apparatus according to any one of the preceding claims, further comprising a wireless remote control for  
5 transmitting at least one wireless control signal for controlling the restriction device.

111. An apparatus according to claim 110, wherein the control signal comprises a frequency, amplitude or frequency or  
10 amplitude modulated signal.

112. An apparatus according to claim 110, wherein the control signal comprises an analog or a digital signal, or a combination of an analog and digital signal.  
15

113. An apparatus according to any of claims 110-112, wherein the remote control is capable of obtaining information on the condition of the implantable restriction device and to control the restriction device in response to the information.  
20

114. An apparatus according to any of claims 110-113, wherein the remote control comprises an implantable control unit for controlling the restriction device.

25 115. An apparatus according to claim 114, wherein the control unit comprises a microprocessor.

116. An apparatus according to any one of claims 110-115, wherein the wireless remote control comprises at least one  
30 external signal transmitter or transceiver and at least one internal signal receiver or transceiver implantable in the patient.

117. An apparatus according to any one of claims 110-115,  
wherein the wireless remote control comprises at least one  
external signal receiver or transceiver and at least one internal  
5 signal transmitter or transceiver implantable in the patient.

118. An apparatus according to any one of claims 110-117,  
wherein the remote control is capable of sending information  
related to the restriction device from inside the patients body  
10 to the outside thereof.

119. An apparatus according to claim 118, wherein the remote  
control controls the restriction device in response to the  
information.

15

120. An apparatus according to any one of claims 110-119,  
wherein the remote control comprises a control signal transmitter  
for transmitting the wireless control signal, and the energy  
transmission device comprises the control signal transmitter,  
20 whereby energy is transmitted by the control signal.

25

121. An apparatus according to any one of claims 110-119,  
wherein the energy transmission device transmits energy by at  
least one signal separate from the control signal.

122. An apparatus according to any one of claims 110-119,  
wherein the remote control transmits a carrier signal for  
carrying the control signal.

30

123. An apparatus according to any one of claims 110-119,  
wherein the energy transmission device transmits energy by at  
least one signal, which is used as a carrier signal for the

control signal transmitted by the remote control.

124. An apparatus according to claim 123, wherein the carrier signal is frequency, amplitude or frequency and amplitude  
5 modulated.

125. An apparatus according to claim 123 or 124, wherein the carrier signal comprises digital, analog or a combination of digital and analog signals.  
10

126. An apparatus according to claim 125, wherein the signals comprise wave signals.

127. An apparatus according to any one of claims 110-126,  
15 wherein the control signal comprises a wave signal comprising one of a sound wave signal, an ultrasound wave signal, an electromagnetic wave signal, an infrared light signal, a visible light signal, an ultra violet light signal, a laser light signal, a micro wave signal, a radio wave signal, an x-ray radiation  
20 signal and a gamma radiation signal.

128. An apparatus according to any one of claims 110-126. wherein the control signal comprises an electric or magnetic field, or a combined electric and magnetic field.  
25

129. An apparatus according to claim 112, wherein the remote control transmits an electromagnetic carrier wave signal for carrying the digital or analog control signal.

130. An apparatus according to claim 2, wherein the energy of the second form used for operating the restriction device is wirelessly transmitted by the energy transforming device.  
30

131. An apparatus according to claim 1, further comprising an implantable control unit for controlling the restriction device.

5

132. An apparatus according to claim 131, wherein the control unit is programmable for controlling the restriction device in accordance with a program.

10

133. An apparatus according to claim 131, wherein the control unit controls the restriction device over time in accordance with an activity schedule program

134. An apparatus according to any one of claims 131-133, further comprising an external wireless remote control for programming the implantable control unit.

135. An apparatus according to claim 1, further comprising an external data communicator and an implantable internal data communicator communicating with the external data communicator, wherein the internal communicator feeds data related to the restriction device back to the external data communicator or the external data communicator feeds data to the internal data communicator.

25

136. An apparatus according to claim 135, wherein the internal data communicator feeds data related to at least one physical signal of the patient.

30

137. An apparatus according to any one of the preceding claims, wherein the restriction device is adapted to control the restriction of the urine passageway when implanted.

138. An apparatus according to any one of the preceding claims, wherein the restriction device is non-inflatable.

5 139. An apparatus according to claim 2, wherein one of the energy of the first form and the energy of the second form comprises magnetic energy, kinetic energy, sound energy, chemical energy, radiant energy, electromagnetic energy, photo energy, nuclear energy or thermal energy.

10

140. An apparatus according to claim 2, wherein one of the energy of the first form and the energy of the second form is non-magnetic, non-kinetic, non-chemical, non-sonic, non-nuclear or non-thermal.

15

141. An apparatus according to claim 1, wherein the energy transmission device functions different from the energy transforming device.

20

142. An apparatus according to claim 2, wherein the energy transmission device functions similar to the energy transforming device.

25

143. An apparatus according to any one of the preceding claims, wherein the energy transforming device is designed to be implanted subcutaneously or in the abdomen, thorax or cephalic region of the patient.

30

144. An apparatus according to any one of claims 1-142, wherein the energy transforming device is designed to be implanted in an orifice of the patient's body and under the mucosa or intraluminal outside the mucosa of the orifice.



145. An apparatus according to any of the preceding claims, wherein the restriction device is embedded in a soft or gel-like material.

5

146. An apparatus according to any of the preceding claims, wherein the restriction device is embedded in a silicone material having hardness less than 20 Shore.

10

15

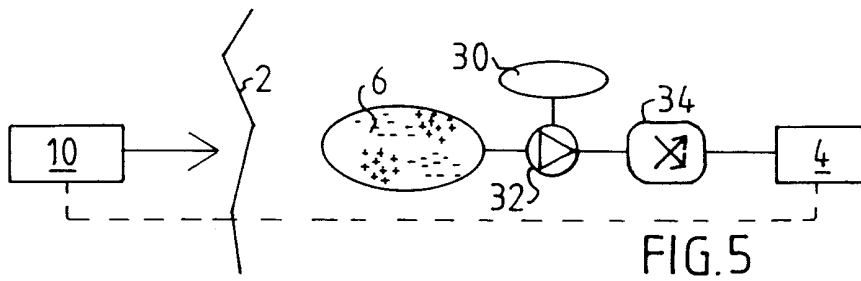
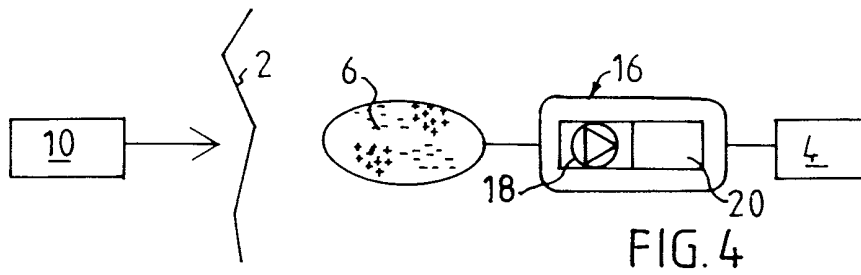
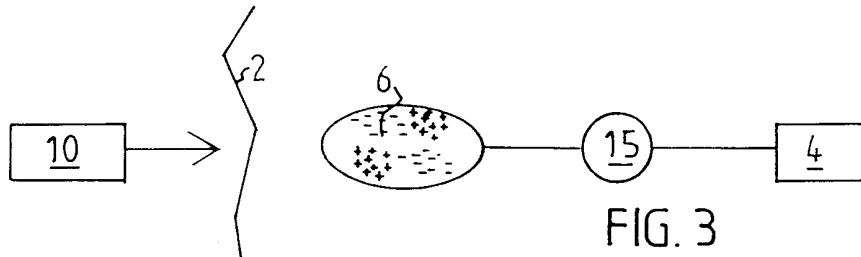
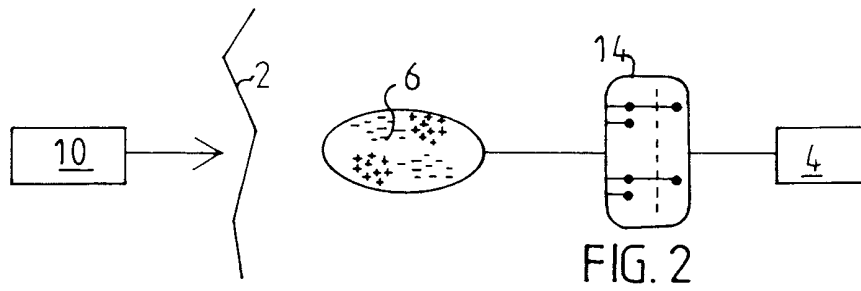
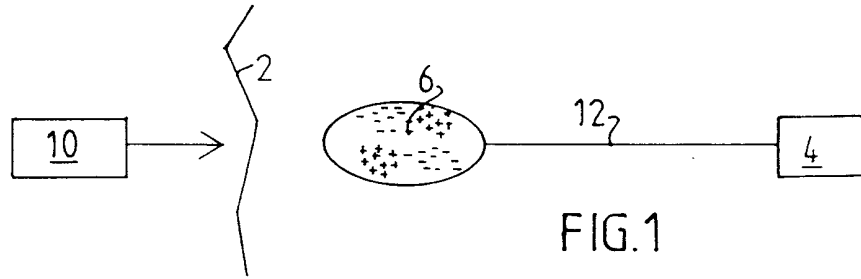

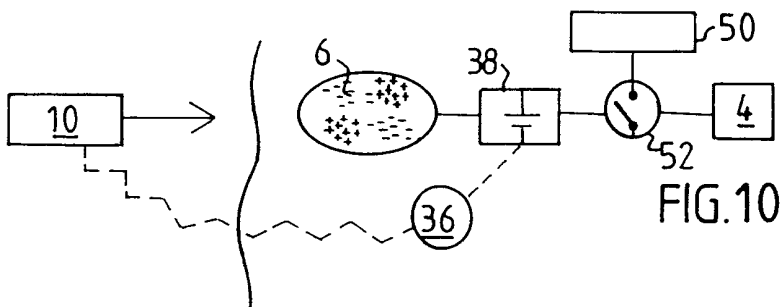
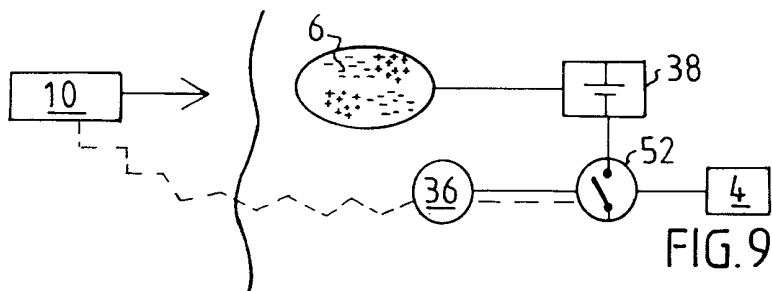
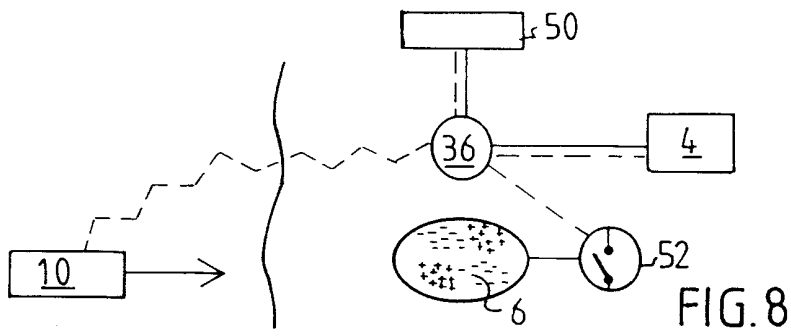
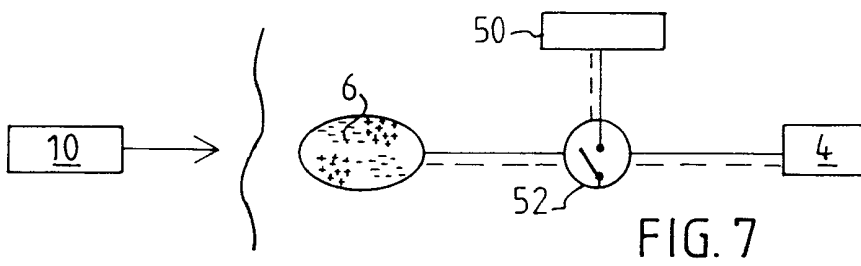
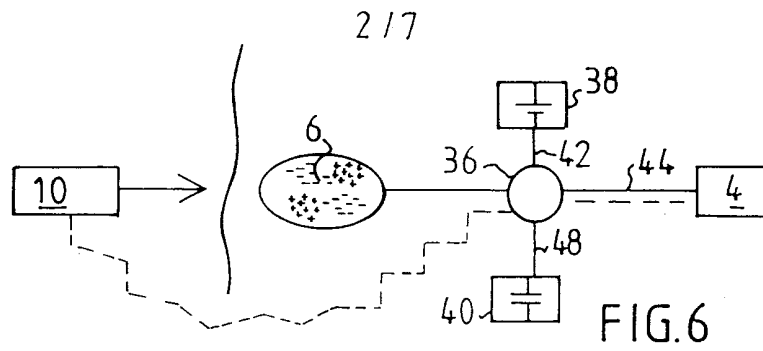

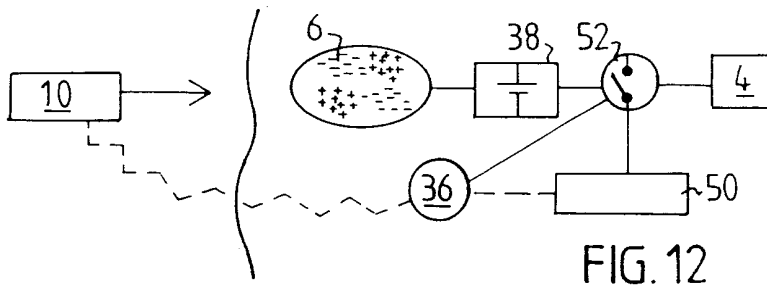
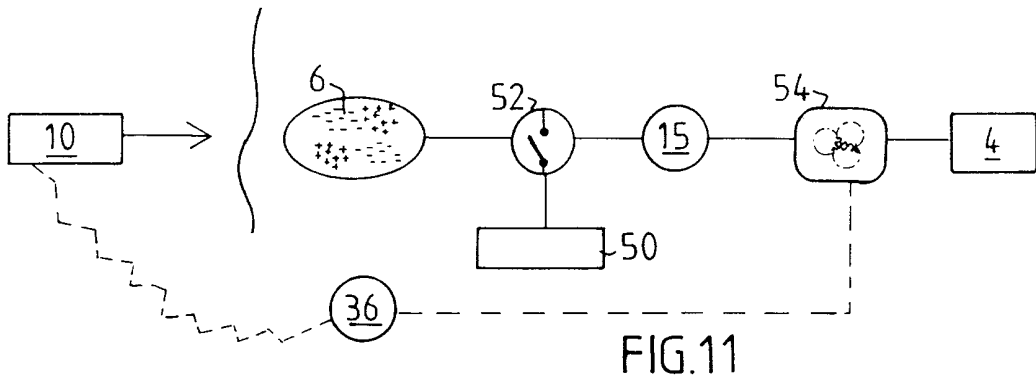

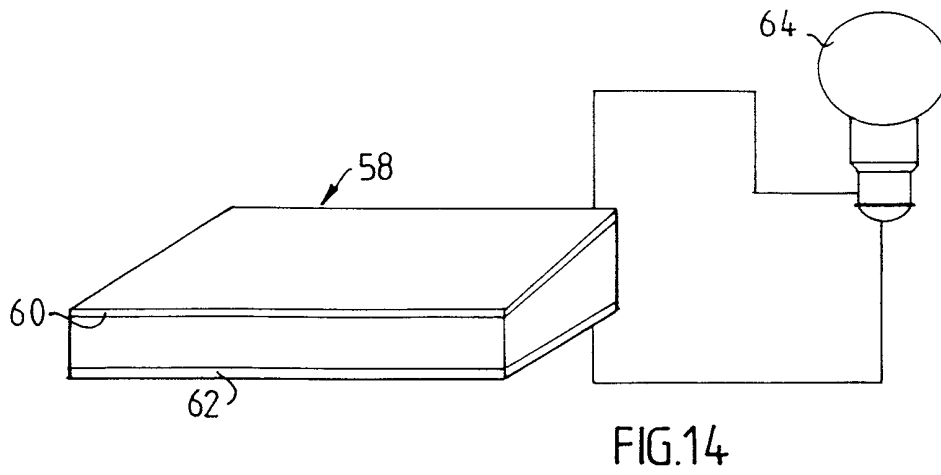
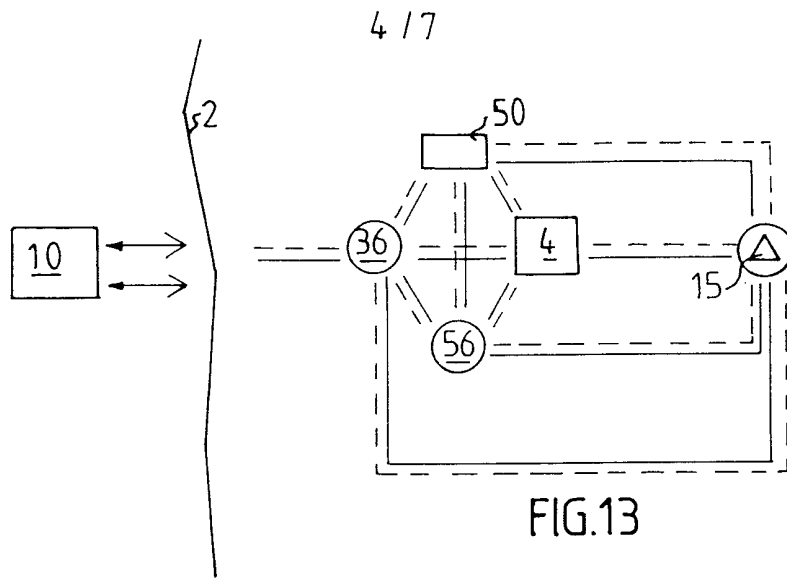

5/7

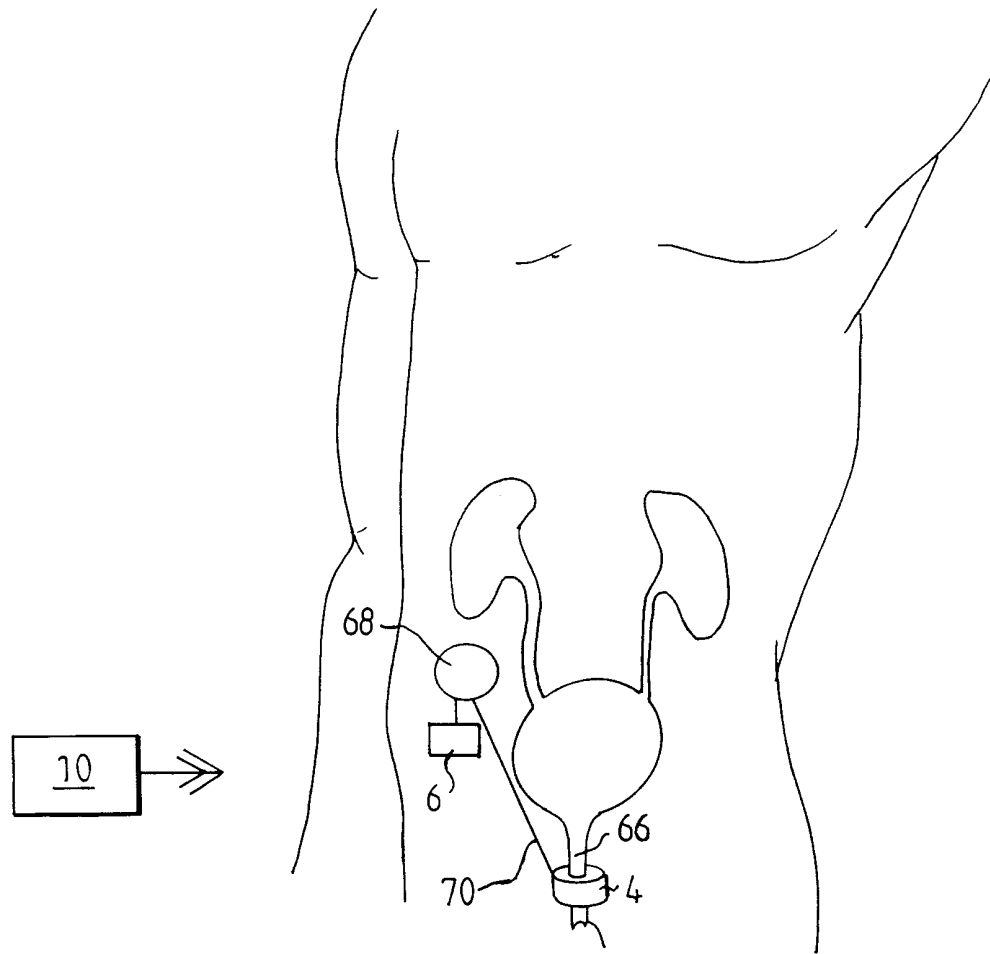

FIG15

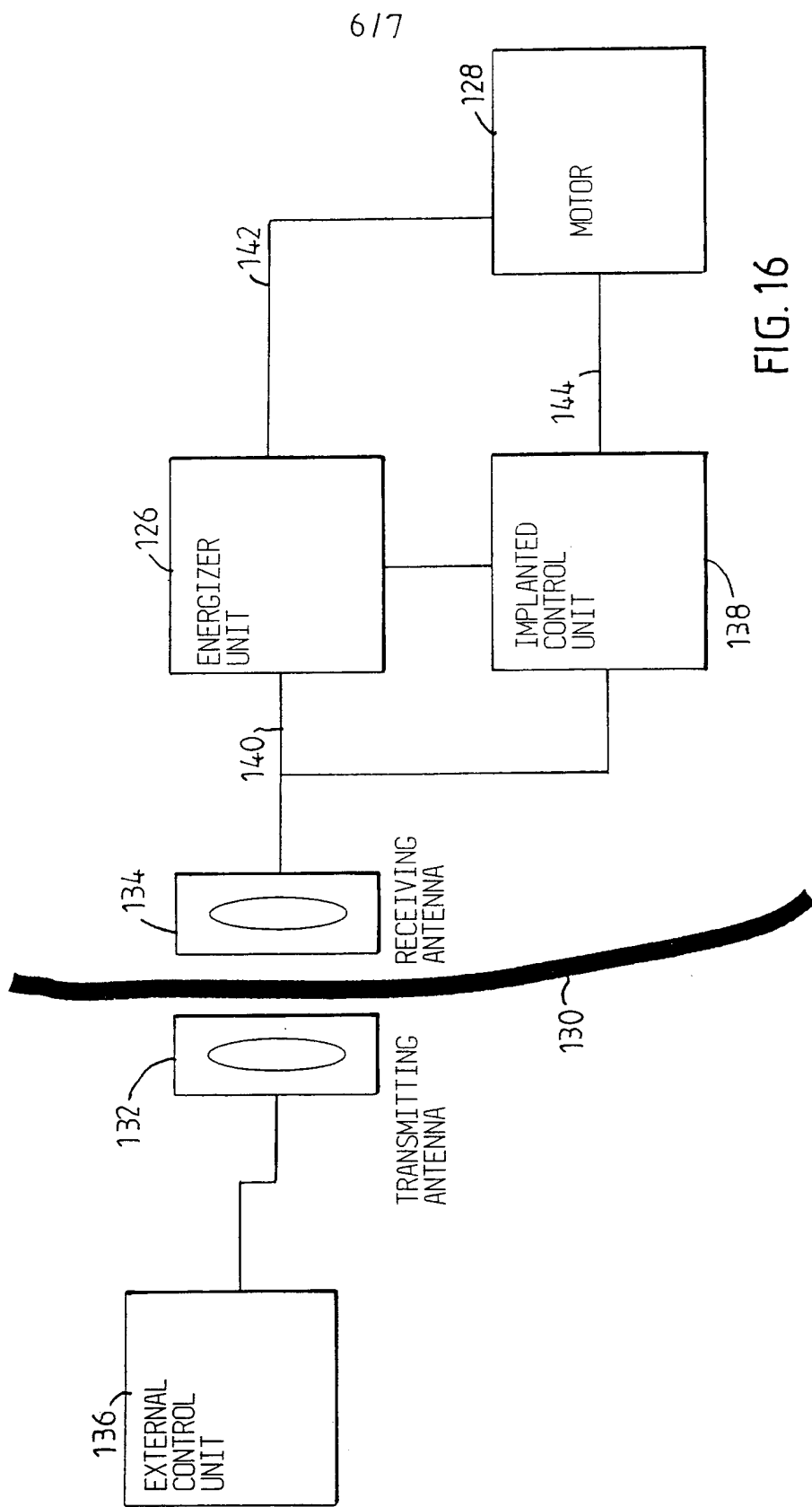

FIG. 16

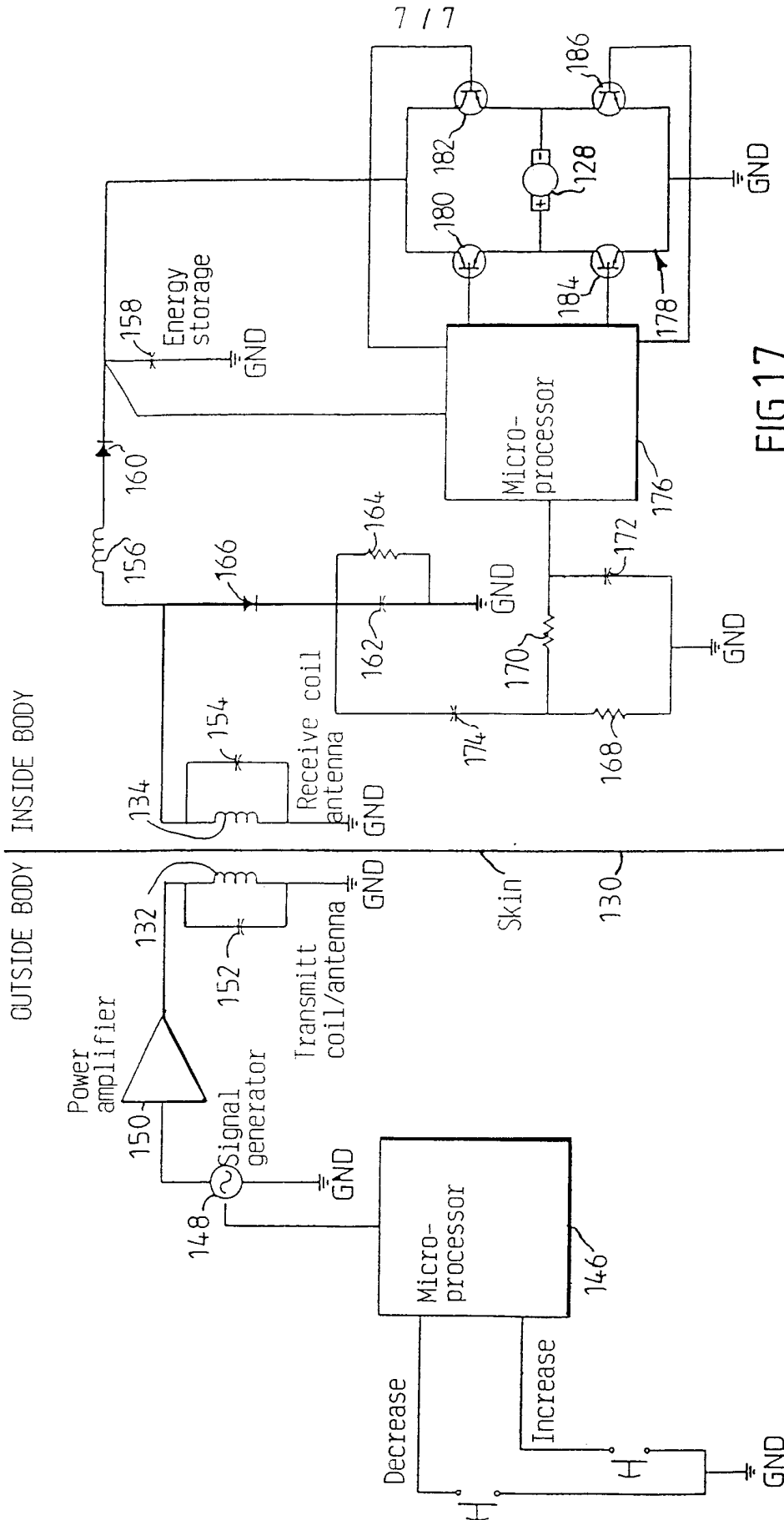

FIG.17



## INTERNATIONAL SEARCH REPORT

International application No.

PCT/SE 01/00270

## A. CLASSIFICATION OF SUBJECT MATTER

IPC7: A61F 2/48, A61F 5/48

According to International Patent Classification (IPC) or to both national classification and IPC

## B. FIELDS SEARCHED

Minimum documentation searched (classification system followed by classification symbols)

IPC7: A61F

Documentation searched other than minimum documentation to the extent that such documents are included in the fields searched

SE,DK,FI,NO classes as above

Electronic data base consulted during the international search (name of data base and, where practicable, search terms used)

EPODOC

## C. DOCUMENTS CONSIDERED TO BE RELEVANT

Category*	Citation of document, with indication, where appropriate, of the relevant passages	Relevant to claim No.
X	FR 2688693 A1 (FERRIERE XAVIER), 19 March 1992 (19.03.92)	1-6, 27, 30, 43-44, 83, 87, 94, 96, 100, 130-131,
X	--	137-144
A	EP 1072238 A1 (UNIVERSIDAD COMPLUTENSE DE MADRID), 31 January 2001 (31.01.01), figures 8-9	1-146
A	US 5509888 A (MILLER), 23 April 1996 (23.04.96)	1-146
	-----	

 Further documents are listed in the continuation of Box C. See patent family annex.

\* Special categories of cited documents:

"A" document defining the general state of the art which is not considered to be of particular relevance

"E" earlier application or patent but published on or after the international filing date

"I" document which may throw doubts on priority claim(s) or which is cited to establish the publication date of another citation or other special reason (as specified)

"O" document referring to an oral disclosure, use, exhibition or other means

"P" document published prior to the international filing date but later than the priority date claimed

"T" later document published after the international filing date or priority date and not in conflict with the application but cited to understand the principle or theory underlying the invention

"X" document of particular relevance: the claimed invention cannot be considered novel or cannot be considered to involve an inventive step when the document is taken alone

"Y" document of particular relevance: the claimed invention cannot be considered to involve an inventive step when the document is combined with one or more other such documents, such combination being obvious to a person skilled in the art

"&amp;" document member of the same patent family

Date of the actual completion of the international search

20 June 2001

Date of mailing of the international search report

26-06-2001

Name and mailing address of the ISA:

Swedish Patent Office  
Box 5055, S-102 42 STOCKHOLM  
Facsimile No. +46 8 666 02 86

Authorized officer

Leif Brander/BS  
Telephone No. +46 8 782 25 00

**INTERNATIONAL SEARCH REPORT**

Information on patent family members

28/05/01

International application No.

PCT/SE 01/00270

Patent document cited in search report			Publication date	Patent family member(s)	Publication date
FR	2688693	A1	19/03/92	NONE	
-----					
EP	1072238	A1	31/01/01	AU 2549500 A	29/08/00
				ES 1041978 U,Y	01/08/99
				ES 2150881 A	01/12/00
				WO 0047141 A	17/08/00
-----					
US	5509888	A	23/04/96	NONE	
-----					