



(51) International Patent Classification:

H02J 7/00 (2006.01) H02J 50/12 (2016.01)

(21) International Application Number:

PCT/CN2016/106366

(22) International Filing Date:

18 November 2016 (18.11.2016)

(25) Filing Language:

English

(26) Publication Language:

English

(71) Applicant: THE UNIVERSITY OF HONG KONG

[CN/CN]; Pokfulam Road, Hong Kong (CN).

(72) Inventors: HUI, Shu Yuen, Ron; 2B, Block 29, Green-

wood Terrace, 26-28 Sui Wo Road, Shatin, New Territories, Hong Kong (CN). ZHANG, Cheng; 3H, Block 2, Golden Building, 150 Fuk Wa Street, Sham Shui Po, Kowloon, Hong Kong (CN).

(74) Agent: CHINA PATENT AGENT (H.K.) LTD.; 22/F.,

Great Eagle Center, 23 Harbour Road, Wanchai, Hong Kong (CN).

(81) Designated States (unless otherwise indicated, for every

kind of national protection available): AE, AG, AL, AM, AO, AT, AU, AZ, BA, BB, BG, BH, BN, BR, BW, BY, BZ, CA, CH, CL, CN, CO, CR, CU, CZ, DE, DJ, DK, DM, DO, DZ, EC, EE, EG, ES, FI, GB, GD, GE, GH, GM, GT, HN, HR, HU, ID, IL, IN, IR, IS, JP, KE, KG, KN, KP, KR, KW, KZ, LA, LC, LK, LR, LS, LU, LY, MA, MD, ME, MG, MK, MN, MW, MX, MY, MZ, NA, NG, NI, NO, NZ, OM, PA, PE, PG, PH, PL, PT, QA, RO, RS, RU, RW, SA, SC, SD, SE, SG, SK, SL, SM, ST, SV, SY, TH, TJ, TM, TN, TR, TT, TZ, UA, UG, US, UZ, VC, VN, ZA, ZM, ZW.

(84) Designated States (unless otherwise indicated, for every

kind of regional protection available): ARIPO (BW, GH, GM, KE, LR, LS, MW, MZ, NA, RW, SD, SL, ST, SZ, TZ,

UG, ZM, ZW), Eurasian (AM, AZ, BY, KG, KZ, RU, TJ, TM), European (AL, AT, BE, BG, CH, CY, CZ, DE, DK, EE, ES, FI, FR, GB, GR, HR, HU, IE, IS, IT, LT, LU, LV, MC, MK, MT, NL, NO, PL, PT, RO, RS, SE, SI, SK, SM, TR), OAPI (BF, BJ, CF, CG, CI, CM, GA, GN, GQ, GW, KM, ML, MR, NE, SN, TD, TG).

Published:

— with international search report (Art. 21(3))

(54) Title: BALL AND SOCKET WIRELESS POWER TRANSFER SYSTEMS

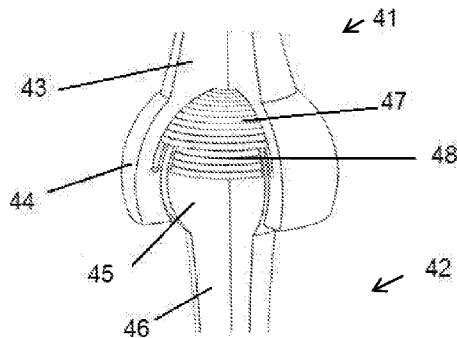

Figure 4B

(57) Abstract: Methods, apparatuses, and systems for wireless power transfer (WPT) in ball-and-socket type structures are provided. A ball and ball-socket structure can include conductive windings and conductive plates having a variety of shapes to optimize WPT over different angles as the ball moves or rotates within the ball-socket. One or both of capacitive coupling and inductive coupling can be incorporated.



## DESCRIPTION

## BALL AND SOCKET WIRELESS POWER TRANSFER SYSTEMS

## BACKGROUND OF THE INVENTION

5           Wireless power transfer based on the magnetic resonance and near-field coupling of two loop resonators was reported by Nicola Tesla a century ago. As pioneered by Tesla, wireless power transfer (WPT) can be radiative or non-radiative depending on the energy transfer mechanisms. Radiative power can be emitted from an antenna and propagate through a medium (such as a vacuum or air) over long distances (i.e., distances much larger than the dimensions of the antenna) in the form of electromagnetic waves. However, due to the omni-directional nature of radiative power emission, the energy transfer efficiency is very low. Non-radiative WPT relies on the near-field magnetic coupling of conductive loops and can be applied in short-range and mid-range contexts, when the transmission distance between the power source and the load is greater than the dimensions of the coil-resonators.

15           WPT has been an active research topic for transcutaneous energy systems for medical implants since the 1960's and for induction heaters since the 1970's. For modern short-range applications, inductive power transfer (IPT) systems and wireless charging systems for portable equipment such as mobile phones have attracted much attention. Wireless charging technology for portable electronic devices has reached the commercialization stage through the launch of the "Qi" Standard by the Wireless Power Consortium, now comprising over 200 companies worldwide.

## BRIEF SUMMARY

25           In spite of the developments in the field of wireless power transfer (WPT), there is still a need for new ways to apply WPT and make it more efficient. Embodiments of the present invention seek to address one or more of these issues and advance the field of wireless power transfer.

30           Embodiments of the present invention include methods, apparatuses, and systems for wireless power transfer (WPT). More specifically, embodiments of the present invention include methods, apparatuses, and systems for WPT in ball-and-socket type structures. Embodiments of the present invention can incorporate capacitive coupling, inductive coupling, or both.

A ball-and-socket joint consists of a rod attached to a ball and a ball-socket that accommodates the ball structure. The ball structure can move over a wide range of angles inside the ball-socket. Embodiments of the present invention include incorporating WPT transmitter and receiver structures within the ball and ball-socket structures. A WPT transmitter or receiver can be located within the ball structure, including the ball and rod. Likewise, a WPT transmitter or receiver can be located within the ball-socket structure, including the ball-socket and its rod or base.

In an embodiment of the present invention, at least one winding can be fit into the ball structure and at least one winding can be fit into the ball-socket structure. Either winding can be used for wireless power transmission and reception so that bidirectional wireless power flow is possible. The transmitter winding and the receiver winding should be electrically isolated. The transmitter coil and the receiver coil can send and receive power over a wide variety of angles while maintaining high power transfer efficiency. Furthermore, the nature of the ball and socket joint allows for rotation (in addition to angular movement) of the ball structure within the ball-socket, without interruption of wireless power transfer.

Wireless power can be transferred between the ball structure and the ball-socket structure through inductive coupling, magnetic resonance, and capacitive coupling. In embodiments of the present invention that apply capacitive WPT, conductive plates can be used instead of windings. Embodiments of the present invention can also transfer data, in addition to power, via the capacitive or inductive coupling.

Potential applications of the present invention include robotic arms, desk lamps, and other moving and hinged structures in which electric power needs to be transferred. The load connected to the power receiving element can be a direct load, power can be transferred to electric circuitry that regulates the received power, and power can be transferred to electric circuitry that charges a battery or other power storage medium. In one aspect, this invention improves upon the prior art by eliminating the need for conductive wires, which can fail after repetitive bending and movement.

#### BRIEF DESCRIPTION OF THE DRAWINGS

**Figure 1** is an illustration of a primary and secondary winding arrangement in a slip-ring structure.

**Figure 2** is an illustration of two co-axial windings in a slip-ring structure for wireless power transfer.

**Figure 3** is an illustration of two co-axial windings for wireless power transfer in a radar system.

**Figure 4A** is an illustration of a WPT ball-and-socket joint according the present invention (with the windings in the ball structure and ball-socket structure exposed for illustration).

**Figure 4B** is an illustration highlighting the windings embedded in the ball structure and the ball-socket structure of an inductive ball and socket WPT system according to an embodiment of the present invention.

**Figures 5(A)** through **5(E)** show several examples of WPT windings embedded within ball structures according to the present invention.

**Figures 6(A)** through **6(D)** show several examples of WPT windings embedded within ball-socket structures according to the present invention.

**Figure 7** shows the position of a ball winding (inside) and a ball-socket winding (outside) according to an embodiment of the present invention.

**Figure 8** is an equivalent circuit diagram of a typical WPT system based on inductive coupling and magnetic resonance.

**Figure 9A** is an illustration of a ball and socket WPT system based on capacitive coupling, according to an embodiment of the present invention (showing exposed views of conductive plates on the ball structure and the ball-socket structure).

**Figure 9B** is a diagram of a ball and socket WPT system based on capacitive coupling (showing the exposed views of the conductive plates on the ball structure and the ball-socket structure).

**Figure 10** is an equivalent circuit diagram of a typical WPT system based on capacitive coupling.

**Figure 11** shows illustrations of winding design with angular variables for optimization.

**Figure 12** shows irregular coils used in a ball and socket WPT system (including segment vectors on the ball coil and socket coil), according to an embodiment of the present invention.

**Figure 13(A)** shows the relative position of a transmitter coil (blue) and a receiver coil (red) for  $\alpha=0$ ,  $\beta=90^\circ$ ,  $\gamma=0$  and  $\delta=90^\circ$  with no displacement angle, according to an embodiment of the present invention.

**Figure 13(B)** shows the relative position of a transmitter coil (blue) and a receiver coil (red) for  $\alpha=0$ ,  $\beta=90^\circ$ ,  $\gamma=0$  and  $\delta=90^\circ$  with a  $45^\circ$  displacement angle, according to an embodiment of the present invention.

**Figure 14** is a graph of calculated and measured mutual inductance versus displacement angle between the two coils shown in Figure 13.

**Figure 15(A)** shows the relative position of a transmitter coil (blue) and a receiver coil (red) for  $\alpha=104.4^\circ$ ,  $\beta=167.4^\circ$ ,  $\gamma=7.2^\circ$  and  $\delta=93.6^\circ$  with no displacement angle, according to an embodiment of the present invention.

**Figure 15(B)** shows the relative positions of the transmitter coil (blue) and receiver coil (red) for  $\alpha=104.4^\circ$ ,  $\beta=167.4^\circ$ ,  $\gamma=7.2^\circ$  and  $\delta=93.6^\circ$  with a  $45^\circ$  displacement angle, according to an embodiment of the present invention.

**Figure 16** is a graph of calculated and measured mutual inductance versus displacement angle between the two coils shown in Figure 15.

**Figure 17A** is a photograph of a conductive winding embedded inside a ball structure of an inductive ball and socket WPT system, according to an embodiment of the present invention.

**Figure 17B** is a photograph of the ball structure of Figure 17A housed in a ball-socket structure.

**Figure 18** is a graph of energy transfer efficiency versus displacement angle for the WPT system shown in Figure 17B.

**Figures 19(A)** and **19(B)** are images of a ball and socket WPT system, according to an embodiment of the present, as applied to an adjustable angle light-emitting diode that is shown in two different positions.

## 25 DETAILED DESCRIPTION

Embodiments of the present invention include WPT methods, apparatuses, and systems that can be applied to ball-and-socket joints. Embodiments of the present can incorporate magnetic induction, magnetic resonance, and capacitive coupling.

The prior art teaches some techniques for applying WPT to mechanical structures. For example, a mechanical slip-ring **10** with primary **1** and secondary **2** windings on the fixed **3** and rotating parts **4** is shown in Figure 1. The primary winding **1** is wound on the stationary (fixed) part **3** of the machine. The secondary winding **2** is wound on the motor shaft **5**, which

can rotate. An air gap **6** is present between the primary winding **1** and secondary winding **2**. Note that the primary winding **1** and the secondary winding **2** share the same axis, and this axis is fixed. In this slip-ring arrangement, the relative positions of the primary **1** and secondary windings **2** remain the same regardless of the rotating speed of the motor shaft **5**.

5 Figure 2 illustrates a second example of WPT systems of the prior art and includes a rotatory transformer **20** with the transmitter and receiver windings placed on two sides of a rotating mechanical structure, which also share the same rotational axis. Like the example of Figure 1, the two windings are fixed co-axially (i.e., they share the same axis and their axes cannot change relative to each other). Similar ideas can be applied to rotating systems, such  
10 as the radar system **30** shown in Figure 3. The radar system **30** in Figure 3 includes a rotating shaft **33**, as well as a coaxial primary winding **31** and a secondary winding **32** that are mounted on the stationary and rotating sides of a radar system **30**, respectively.

Figures 4A and 4B show examples of ball-and socket WPT systems according to an embodiment of the present invention. Figures 4A and 4B show a ball structure **42** and a ball-  
15 socket structure **41**. The ball structure **42** includes a ball rod **46** connected to a ball **45** and a first conductive winding **48**. The socket structure **41** includes a ball-socket **44** connected to a socket rod **43** and a second conductive winding **47**. The ball **45** is located within the ball-socket **44** forming a smooth interface, which allows for movement in all directions as well as rotation. Materials that can be used include metals, plastics, silicon based materials, and  
20 ceramics, and lubricants can be provided within the ball-socket joint to further reduce friction.

Figures 5(A) through 5(E) show examples of different conductive windings that can be embedded within ball structures of the present invention. Figures 6(A) through 6(D) show examples of conductive windings that can be embedded within ball-socket structures according to the present invention. In Figures 5 and 6, a “cross” (X) refers to current entering  
25 the plane and a “dot” (•) refers to current coming out of the plane. However, for inductive power transfer (IPT), high-frequency alternating current (AC) will flow through the windings and the current direction will alternative.

Figure 5(A) shows a ball structure having conductive windings embedded near the surface of the lower hemisphere of the ball (opposite the ball rod). Figure 5(B) shows  
30 conductive windings embedded on the upper hemisphere of the ball. Figure 5(C) shows conductive windings formed in a circular fashion on the equatorial plane of the ball (on the plane that is perpendicular to the ball-rod). Figure 5(D) shows another example of internal winding placement within the rod, wherein the windings wrap around the axis of the ball-rod,

are stacked vertically and horizontally, yet do not extend all the way to the top and side surfaces of the ball. Figure 5(E) shows another example of surface windings of the ball. As seen in Figure 5(E), windings can begin at the equatorial plane of the ball and extend upwards and downwards from the equatorial plane (e.g., 10, 20, 30, 40, 50, 60, 70, and 80  
5 degrees upwards, downwards, or both upwards and downwards from the equatorial plane), yet not reach the top or bottom of the ball. Embodiments of the present invention can also include additional winding structures to those shown in Figures 5(A) to 5(E), including combinations of the winding structures of Figures 5(A) to 5(E).

Figure 6 shows several examples of how windings can be incorporated in socket-  
10 structures of the present invention. Figure 6(A) shows windings placed equatorially on a ledge of the ball-socket. Figure 6(B) shows windings placed just below the inner surface of the bottom hemisphere of the ball-socket. Figure 6(C) shows an embodiment in which windings are placed near the surface of the ball-socket, without the windings extending all the way to the equator or bottom of the ball-socket. Figure 6(D) shows another example in which  
15 conductive windings are placed on the ledge of ball socket and extend partially into the ball-socket itself. Embodiments of the present invention can also include additional winding structures to those shown in Figures 6(A) to 6(D), including combinations of the winding structures of Figures 6(A) to 6(D). Again, the windings embedded within the ball structure and ball-socket structure can be used as both transmitter and receiver coils in the present  
20 invention, allowing for bi-directional power flow.

According to an embodiment of the present invention, an apparatus for wireless power transfer can include a ball including a first conductive winding and a ball-socket including a second conductive winding. The first conductive winding should be electrically isolated from the second conductive winding.

25 The first conductive winding and the second conductive winding can each take the shape of one or more parts of a surface of a sphere. For example, the first conductive winding and second conductive winding can each take the shape of a hemisphere, part of a hemisphere, a band formed along a sphere, two bands formed along a sphere, three (or four, five, or six...) bands formed along a sphere, a sphere cap and one or more bands, two or more  
30 concentric spherical bands, and concentric hemispheres.

A sphere can be defined as having a top (away from the socket opening or towards the rod) at 90 degrees and a bottom at -90 degrees, wherein the equatorial line is 0 degrees. Each of the bands or parts of the sphere can span a range having any of the following values

as endpoints (with or without “about” in front of one or both of the endpoints), though embodiments are not limited thereto (all numerical values are in degrees): 0, 5, 10, 15, 20, 25, 30, 35, 40, 45, 50, 55, 60, 65, 70, 75, 80, 85, 90, -5, -10, -15, -20, -25, -30, -35, -40, -45, -50, -55, -60, -65, -70, -75, -80, -85, and -90. For example, a winding in the shape of a hemisphere can range from 0 degrees to 90 degrees. In a second example, a winding can take the shape of a band on the surface of a sphere extending from 15 to -15 degrees. In a third example, a first band extending from 15 to -15 degrees and having a first radius can be placed within a second band extending from 15 to -15 degrees and having a second radius, which is greater than the first radius. In a fourth example, a winding can include a hemispherical cap extending from 90 to 60 degrees in combination with a band extending from 10 degrees to -10 degrees. In a fifth example, a winding can have a first band extending from 30 degrees to 40 degrees and a second band extending from 10 to 20 degrees.

The windings of the ball-socket can be included partially or completely within a ledge of the ball-socket. The winding of the ball and the ball-socket can take the form of complete or partial opposing hemispheres (see Figure 15) or complete or partial concentric hemispheres, as shown in Figure 13. The conductive windings of the ball or ball-socket can also extend into their respective rods or supporting structures. The radius of the sphere and thickness of the conductive windings can be determined based on the size and application of the ball-and-socket joint.

When the ball structure rotates, the axis of the ball winding and the ball-socket winding can point in different directions. One example of this is shown in Figure 7, wherein the ball-socket windings **71** are shown covering ball windings **72**, yet their axes are positioned at different angles.

An investigation will now be had into the scientific principles that underlie the present invention. Certain assumptions will be made to simplify the analysis, such as apparatus dimensions and angular restrictions. However, these assumptions are only made for simplifying the experimental investigation, and it should be clear that embodiments of the present invention are in no way limited by these assumptions.

Figure 8 is an equivalent circuit diagram of a typical WPT system based on inductive coupling and magnetic resonance. A capacitor ( $C_{Tx}$  or  $C_{Rx}$ ) is generally used in each coil (inductor) to form a resonant tank because energy transfer efficiency can be increased in WPT systems when they operate at or near their resonance frequency. The power that can be transferred from the transmitter coil to the receiver coil is proportional to the operating

frequency, mutual inductance between the transmitter (Tx) and receiver (Rx) coils, and the square of the transmitter coil current:

$$P \propto fMI_{Tx}^2 \quad (1)$$

5

where  $M$  is the mutual inductance between Tx and Rx coils,  $f$  is the operating frequency of the AC source, and  $I_{Tx}$  is the current of the Tx coil excitation. The currents and voltages in the system can be calculated by the following equation:

10

$$\begin{bmatrix} R_{Tx} + jX_{Tx} & j\omega M \\ j\omega M & R_{Rx} + jX_{Rx} \end{bmatrix} \begin{bmatrix} I_{Tx} \\ I_{Rx} \end{bmatrix} = \begin{bmatrix} V_{Tx} \\ 0 \end{bmatrix} \quad (2)$$

15

where  $R_{Tx}$  is the total serial resistance of the transmitter circuit,  $X_{Tx}$  is the total serial reactance of the transmitter circuit and is equal to  $\omega L_{Tx} - \frac{1}{\omega C_{Tx}}$  if the compensating capacitor is serially connected as illustrated in Figure 8.  $R_{Rx}$  and  $X_{Rx}$  are the parameters for the receiver circuit,  $M$  is the mutual inductance between Tx and Rx coils,  $I_{Tx}$  and  $I_{Rx}$  are the currents flowing through the transmitter and receiver circuits, and  $V_{Tx}$  is the AC voltage applied to the transmitter circuit. Instead of windings in the ball structure and ball-socket structure, two conductive plates can be used to form a capacitor and WPT can be achieved through capacitive coupling.

20

25

Figures 9A and 9B show illustrations of a ball-and-socket WPT apparatus that incorporates capacitive coupling. Figures 9A and 9B have cutaways so that the ball-socket structure conductive plates **91** and **92** and the ball structure conductive plates **93** and **94** can be seen. That is, embodiments of the present invention can include an upper ball-socket structure conductive plate **91**, a bottom ball-socket structure conductive plate **92**, an upper ball structure conductive plate **93**, and a bottom ball structure conductive plate **94**. An equivalent circuit of a capacitive WPT system, such as those of Figures 9A and 9B, is shown in Figure 10. The conductive plates can be made of copper, aluminum or other metals or alloys with low resistance.

30

A first conductive plate (which can have multiple distinct parts) can be located in the ball, and a second conductive plate (which can have multiple distinct parts) can be located in the ball-socket. The first conductive plate and the second conductive plate can each take the

shape of one or more parts of a surface of a sphere. For example, the first conductive plate and second conductive plate can each take the shape of the surface of a hemisphere, part of a hemisphere, a band formed along a sphere, two bands formed along a sphere, three (or four, five, or six...) bands formed along a sphere, a sphere cap and one or more bands, two or more concentric spherical bands, and concentric hemispheres.

A sphere can be defined as having a top (away from the socket opening or towards the rod) at 90 degrees and a bottom at -90 degrees, wherein the equatorial line is at 0 degrees. Each of the bands or parts on the surface of the sphere can span a range of angles, for example, having any of the following values as endpoints (with or without "about" in front of one or both of the endpoints), though embodiments are not limited thereto (all numerical values are in degrees): 0, 5, 10, 15, 20, 25, 30, 35, 40, 45, 50, 55, 60, 65, 70, 75, 80, 85, 90, -5, -10, -15, -20, -25, -30, -35, -40, -45, -50, -55, -60, -65, -70, -75, -80, -85, and -90. For example, a plate in the shape of a hemisphere surface can range from 0 to 90 degrees. In a second example, a plate can take the shape of a band on the surface of a sphere extending from 15 to -15 degrees. In a third example, a first band extending from 15 to -15 degrees and having a first radius can be placed within a second band extending from 15 to -15 degrees and having a second radius, which is greater than the first radius. In a fourth example, a plate can include a hemispherical cap extending from 90 to 70 degrees in combination with a band extending from 10 degrees to 30 degrees, similar to what is shown in Figures 9A and 9B. In a fifth example, a plate can have a first band extending from 30 degrees to 40 degrees and a second band extending from 10 to 20 degrees.

The plate of the ball-socket can be included partially or completely within a ledge of the ball-socket. The plate of the ball and the ball-socket can take the form of complete or partial opposing hemispheres (see Figure 15) or complete or partial concentric hemispheres, as shown in Figure 13. The conductive plates of the ball or ball-socket can also extend into their respective rods or supporting structures. The radius of the sphere and thickness of the plates can be determined based on the application of the ball-and-socket joint.

The power stored via capacitance that is transferrable is:

$$P \propto fCV_{T_x}^2 \quad (3)$$

where  $C$  is the capacitance between the Tx and Rx electrodes, and  $V_{Tx}$  is the AC voltage applied on the Tx electrodes. For planar electrodes, the capacitance can be calculated by the following equation.

$$C = \frac{\epsilon A}{d} \quad (4)$$

5

In order to maximize the capacitance for capacitive WPT, the distance ( $d$ ) between the conductive layer in the ball structure and that in the ball-socket structure should be as small as practically possible, and the overlap area ( $A$ ) of the transmitter and receiver conductive plates should be as large as possible.

10

Because inductance is affected by the size, shape, number of windings, and orientation, there can be significant variations in efficiency and power transfer in embodiments of the present invention that rely on IPT. Therefore, winding design should be carefully examined to minimize the fluctuation of mutual inductance between the two windings over a wide angular range. Considering the nature of ball-and-socket joints, the most practical implementation is to wind coils near the surface of both the ball structure and ball-socket structure. The symmetrical winding scheme can be defined by the parameters

15

specified in Figure 11 and tabulated in Table I.

TABLE I. PARAMETERS OF EMBEDDED COILS IN BALL AND SOCKET

Parameter	Symbol	Unit
Cross section radius of the wire	$\rho$	m
Interval between two turns of wire	$\Delta l$	m
Number of turns	N	
Ball winding starting angle	$\alpha$	deg
Ball winding ending angle	$\beta$	deg
Socket winding starting angle	$\gamma$	deg
Socket winding ending angle	$\delta$	deg
Ball winding radius	$r_b$	m
Socket winding radius	$r_s$	m
Displacement angle between ball and socket	$\theta$	deg

20

To produce a simplified model for a basic understanding of the how different factors affect power transfer and efficiency, several assumptions have been made. First, for this investigation, the windings in the ball-socket are assumed not to cover more than a hemisphere (of course, embodiments of the present invention can include more than windings

25

of just a hemisphere). Second, the coils are assumed to be wound symmetrically along the vertical axes, as shown in Figure 11 (of course, embodiments of the present invention can include windings that are not symmetrical about the vertical axis). Due to the symmetry of the windings, only one displacement angle  $\theta$  is needed to identify the relative position between the windings of the ball and the ball-socket.

Therefore

$$0 < \alpha < \beta < 180^\circ \tag{5}$$

$$0 < \gamma < \delta < 90^\circ \tag{6}$$

$$0 < \theta < 90^\circ \tag{7}$$

where the angular variables  $\alpha, \beta, \gamma$  and  $\delta$  are specified as shown in Figure 11.

Turning to the two coils, the ball coil  $C_b$  and socket coil  $C_s$  shown in Figure 12, the windings are irregular. Therefore, it is difficult to derive equations to calculate the self-inductance and mutual-inductance values directly. The calculation can be based on Neumann's formula.

$$L_{m,n} = \frac{\mu_0}{4\pi} \oint_{C_m} \oint_{C_n} \frac{d\mathbf{x}_m \cdot d\mathbf{x}_n}{|\mathbf{x}_m - \mathbf{x}_n|} \tag{8}$$

where  $L_{m,n}$  is the inductance between the two general coil  $m$  and coil  $n$ . Self-inductance is calculated when  $m = n$ .  $\mu_0$  is the vacuum permeability if no magnetic material is used.  $\mathbf{x}_m$  and  $\mathbf{x}_n$  are infinitesimal length vectors along the coil  $m$  and  $n$ . The denominator in the integral can be approximated as zero when calculating the self-inductance and when  $\mathbf{x}_m \equiv \mathbf{x}_n$ . In such situations, special handling techniques are required. The following equation can be used to replace the partial element at the singularity.

$$L_p = \frac{\mu}{2\pi} \left[ l \cdot \log \frac{l + \sqrt{l^2 + \rho^2}}{\rho} - \sqrt{l^2 + \rho^2} + \frac{l}{4} + \rho \right] \tag{9}$$

Where  $L_p$  is a partial inductance of one segment of coil,  $l$  equals the length of the discretized vector element of the wire and  $\rho$  is the radius of the cross section of the wire.

The trajectory of the ball coil  $C_b$  and socket coil  $C_s$  can be generated and stored in vector arrays. Each segment in the array is assumed to have the same length. Thus, the value of  $L_p$  is a fixed value.

$$C_b = \{\mathbf{x}_{b_1}, \mathbf{x}_{b_2}, \dots, \mathbf{x}_{b_n}\} \tag{10}$$

$$C_s = \{\mathbf{x}_{s_1}, \mathbf{x}_{s_2}, \dots, \mathbf{x}_{s_m}\} \tag{11}$$

When the Neumann's formula (8) is applied to the setup in Fig.12, mutual-inductance  $M_{C_b, C_s}$  between the ball coil  $C_b$  and socket coil  $C_s$  is the summation of all the partial inductance values:

$$M_{C_b, C_s} = \sum_{i=1}^n \sum_{j=1}^m \frac{\mu_0}{4\pi} \frac{X_{b_i} X_{s_j}}{X_{b_i} - X_{s_j}} \quad (12)$$

5 For the self-inductance of each coil, equation (9) is used to determine one partial inductance value when  $i = j$ . The self-inductance equation of each coil  $L_C$  is the summation of all the partial inductance value:

$$L_C = \sum_{i=1}^n \sum_{j=1}^m \begin{cases} \frac{\mu_0}{4\pi} \frac{X_i X_j}{X_i - X_j} & i \neq j \\ L_p & i = j \end{cases} \quad (13)$$

10 The general self-inductance equation (13) applies to both ball coil  $C_b$  and socket coil  $C_s$  in Figure 12.

With any given mechanical structure of a ball joint, the inner and outer radius is determined. Therefore the optimizable parameters are the four angular variables  $\alpha, \beta, \gamma$  and  $\delta$ . Since the equations are complicated, a genetic algorithm was used to find the optimal values of the start and end points of the coils. In order to minimize the variation of mutual inductance over a wide angular movement of the ball structure within the ball-socket, the mutual inductance values were calculated with a series of  $\theta$  values. Assuming that the mutual inductance values at  $K$  different angular positions are obtained, the mean value of the mutual inductance is:

$$\mu_M = \frac{1}{K} (M|_{\theta_1} + M|_{\theta_2} + \dots + M|_{\theta_K}) \quad (14)$$

20 The standard deviation of these  $K$  inductance values is:

$$SD = \sqrt{\frac{1}{K} \sum_{i=1}^K (M|_{\theta_i} - \mu_M)^2} \quad (15)$$

A fitness function is defined as:

$$\text{fitness}(\alpha, \beta, \gamma, \delta) = \frac{\mu_M}{SD} + \mu_M \times 10^{-6} \quad (16)$$

The genetic algorithm that was adopted to optimize the objective function is defined as:

$$25 \quad J(\alpha, \beta, \gamma, \delta) = \max[\text{fitness}(\alpha, \beta, \gamma, \delta)] \quad (17)$$

Simulations and experiments were carried out to evaluate, optimize, and ultimately determine the physical structure for different embodiments of the present invention. The

physical dimensions of the ball joint were determined first. It was assumed that the ball coil radius was 4 cm and the socket coil radius was 5 cm. The cross-sectional radius of the wire was assumed to be 0.75mm thick. Theta ( $\theta$ ) was selected from 0 to 90°, with 5° intervals. The displacement angles selected were 0, 5°, 10°, 15°, ..., and 80°, as most practical ball joints will have dead zones. In this study, the windings embedded in the ball-socket were used as the transmitter coil, while the windings embedded in the ball acted as the receiver coil. The ball and ball-socket structures were fabricated using a 3D printer. The rotating angle of the ball structure in the socket was from 0° to about 90°.

Figures 13(A) and 13(B) show hemispherical winding in both the ball and ball-socket structures. Specifically, Figure 13(A) shows the relative position of the transmitter coil (blue) and receiver coil (red) for  $\alpha=0$ ,  $\beta=90^\circ$ ,  $\gamma=0$  and  $\delta=90^\circ$  with no displacement angle; and Figure 13(B) shows the relative position of the transmitter coil (blue) and receiver coil (red) for  $\alpha=0$ ,  $\beta=90^\circ$ ,  $\gamma=0$  and  $\delta=90^\circ$  with a 45° displacement angle.

In Figures 13(A) and 13(B), the position of the windings embedded in the ball and ball-socket structures can be seen, with each Figure showing a different orientation. The number of turns in the ball structure was  $N_{Rx}=36$  (red coil) and that of the ball-socket was  $N_{Tx}=38$  (blue coil). The four angular parameters in this standard winding structure is tabulated in Table II.

Table II: Parameters for a Set of Standard Windings

Parameter	Optimal value
$\alpha$	0
$\beta$	90°
$\gamma$	0
$\delta$	90°

Based on the mutual inductance calculations explained above, the mutual inductance values over a wide range of displacement angles were calculated and plotted with the measured values as shown in the graph of Figure 14. From Figure 14 it can be seen that the mutual inductance values change substantially (from 33.4  $\mu\text{H}$  to -0.61  $\mu\text{H}$ ) when the displacement angle changes from 0 to 80°. While this inductance profile has high inductance values (and thus high energy efficiency in WPT), there is a certain angular range (e.g. from 60° to 80°) in which the inductance values are relatively low.

A second set of windings, as shown in Figure 15, were designed to minimize the variation in mutual inductance. As with the previously discussed winding design,  $N_{Tx}=40$  (blue coil) and  $N_{Rx}=26$  (red coil). For this GA-optimized winding design, the mutual inductance values had much less variation from 0 to 75°. Specifically, the variation only ranged from 10.1  $\mu\text{H}$  to 8.03  $\mu\text{H}$  over a displacement angle range from 0 to 75°. The parameters of this hardware prototype are listed in Table IV. The four optimized parameters of the coil windings have been solved by the GA and are listed in TABLE III. The calculated mutual inductance values and the measured inductance values can be seen in the graph of Figure 16.

TABLE III. OPTIMIZED PARAMETERS BY GENETIC ALGORITHM

Parameter	Optimal value
$\alpha$	104.4°
$\beta$	167.4°
$\gamma$	7.2°
$\delta$	93.6°

TABLE IV. PARAMETERS OF THE BALL JOINT

Parameter	Unit	Value
Ball coil radius	cm	4
Socket coil radius	cm	5
Load impedance	Ohm	51
Ball coil self-inductance	$\mu\text{H}$	27
Socket coil self-inductance	$\mu\text{H}$	110
Operating frequency	kHz	867

A 3D-printed ball-and-socket structure according to the present invention was constructed. The coils were wound using a litz wire and the parameters acquired from the optimized results. Both coils were connected in series with compensating capacitors in order to form resonant tanks with resonant frequencies that were identical to the operating frequencies. The receiver at the ball side was connected with an output load  $51\Omega$  non-inductive resistor. The power source was a 10W sinusoidal voltage generator.

Figure 17A shows exposed windings inside a ball structure. The exposed ball structure was then covered by a thin outer sheet of material, and the ball structure was placed

in the ball-socket structure as shown in Figure 17B. The energy efficiency was measured for a wide angular range and plotted in the graph of Figure 18. The results can also be seen in Table V. The energy efficiency stayed above 87% from 0 to 75°. Even at a displacement angle of 90°, a reasonably high energy efficiency of 85.7% was achieved.

5

TABLE V. MEASURED CURRENT, VOLTAGE AND POWER VALUES AT DIFFERENT DISPLACEMENT ANGLES

10

$\theta$ (deg)	$V_{in}$ (RMS,V)	$I_{in}$ (RMS,mA)	$P_{in}$ (mW)	$V_{out}$ (RMS,V)	$I_{out}$ (RMS,mA)	$P_{out}$ (mW)	$\eta$ (%)
0	2.12	99.4	202	3.12	60.0	182	90.1%
15	2.20	97.4	213	3.16	61.0	188	88.3%
30	2.38	94.5	223	3.22	62.0	197	88.3%
45	2.53	92.0	229	3.26	63.4	202	88.2%
60	2.48	93.0	228	3.24	63.0	200	87.7%
75	2.08	101	205	3.09	60.5	182	88.8%
90	2.11	116	112	2.27	45.0	96	85.7%

An LED load was used in the receiver for demonstration purposes as shown in Figures 19(A) and 19(B). The images of Figures 19(A) and 19(B) show that the brightness of the LED load was similar in the two displacement angles.

15

In another proof of concept experiment, power transfer efficiency was measured for an experimental embodiment of the present invention. The measured power efficiency ranged from 87.1% to 94.4% over a variety of different angles, as can be seen in Table VI. The results recorded in Table VI were obtained using the design shown in Figure 15 and the actual prototype used to conduct the experiment is shown in Figures 17A and 17B. The two axes of the transmitter and receiver coil resonators were used for the relative angle, measured in degrees. When the transmitter and receiver are in-line, the angular position is 0 degrees. The ball structure was then rotated at different angles and the input and output power values were measured, and the energy efficiency values were then calculated.

20

25

TABLE VI. Experimental Embodiment Power Transfer Efficiency

Degree	$V_{in}$ (RMS)	$I_{in}$ (RMS)	$P_{in}$	$V_{out}$ (RMS)	$I_{out}$ (RMS)	$P_{out}$	Eff
0	5.435	0.03165	<b>0.16985</b>	2.028	0.07845	<b>0.1587</b>	<b>93.43%</b>
15	5.53	0.02980	<b>0.16263</b>	1.988	0.07733	<b>0.1535</b>	<b>94.39%</b>

30	5.56	0.02939	<b>0.16100</b>	1.976	0.07692	<b>0.1520</b>	<b>94.41%</b>
45	5.57	0.02927	<b>0.16090</b>	1.975	0.07697	<b>0.1510</b>	<b>93.85%</b>
60	5.43	0.03230	<b>0.17300</b>	2.03	0.07920	<b>0.1600</b>	<b>92.49%</b>
75	4.98	0.04160	<b>0.20364</b>	2.18	0.08500	<b>0.1855</b>	<b>91.11%</b>
90	3.98	0.06450	<b>0.23300</b>	2.28	0.08900	<b>0.2030</b>	<b>87.12%</b>

5           The subject invention includes, but is not limited to, the following exemplified embodiments.

Embodiment 1. An apparatus for wireless power transfer comprising:

10           a ball including a first conductive winding; and  
a ball-socket including a second conductive winding,  
wherein the first conductive winding is electrically isolated from the second  
conductive winding.

15           Embodiment 2. The apparatus of Embodiment 1, wherein the first conductive winding takes a  
shape from one or more parts of a surface of a sphere [e.g., a hemisphere, part of a  
hemisphere, a band formed along a sphere, two bands formed along a sphere, three (or  
four, five, or six...) bands formed along a sphere, a sphere cap and one or more bands,  
two or more concentric spherical bands, and concentric hemispheres].

20           Embodiment 3. The apparatus of any of Embodiments 1 to 2, wherein the first conductive  
winding is planar equatorial [e.g., a ring or band around the central axis and on the  
equatorial plane, a complete planar equatorial winding, or a planar equatorial winding  
that starts at the center of the ball and only extends partially to the surface of the ball].

25           Embodiment 4. The apparatus of any of Embodiments 1 to 3, wherein the first conductive  
winding includes an internal stack (where the windings are vertically stacked, such as  
that shown in Figure 5D).

Embodiment 5. The apparatus of any of Embodiments 1 to 4, wherein the first conductive winding takes the shape of an internal saucer (such as that shown in Figure 5D).

5 Embodiment 6. The apparatus of any of Embodiments 1 to 5, wherein the second conductive winding takes a shape from one or more parts of a surface of a sphere [e.g., a hemisphere, part of a hemisphere, a band formed along a sphere, two bands formed along a sphere, three (or four, five, or six...) bands formed along a sphere, a sphere cap and one or more bands, two or more concentric spherical bands, and concentric hemispheres].

10

Embodiment 7. The apparatus of any of Embodiments 1 to 6, wherein the second conductive winding is located partially or completely within a ledge of the ball-socket.

15 Embodiment 8. The apparatus of any of Embodiments 1 to 7, wherein the first conductive winding and the second conductive winding take the form of opposing hemispheres (or partial spheres; see, e.g., Figure 15) or partial opposing hemispheres (or concave and convex hemispheres, as shown in Figure 13).

20 Embodiment 9. The apparatus of any of Embodiments 1 to 8, wherein the first conductive winding extends within a rod attached to the ball (not shown).

Embodiment 10. The apparatus of any of Embodiments 1 to 9, wherein the second conductive winding extends within a rod attached to the ball-socket (not shown).

25 Embodiment 101. An apparatus for wireless power transfer comprising:  
a ball including a first conductive plate (which can include multiple distinct parts);  
and  
a ball-socket including a second conductive plate (which can include multiple distinct parts) ,  
30 wherein the first conductive plate is electrically isolated from the second conductive plate.

- Embodiment 102. The apparatus of Embodiment 101, wherein the first plate takes a shape from one or more parts of a surface of a sphere [e.g., a hemisphere, part of a hemisphere, a band formed along a sphere, two bands formed along a sphere, three (or four, five, or six...) bands formed along a sphere, a sphere cap and one or more bands, two or more concentric spherical bands, and concentric hemispheres].
- 5
- Embodiment 103. The apparatus of any of Embodiments 101 to 102, wherein the first conductive plate is planar equatorial (e.g., forming an equatorial plate that extends to just below the surface of the ball, or a planar equatorial plate that starts at the center of the ball and only extends partially towards the surface of the ball).
- 10
- Embodiment 104. The apparatus of any of Embodiments 101 to 103, wherein the first conductive plate includes a stack of plates.
- 15
- Embodiment 105. The apparatus of any of Embodiments 101 to 104, wherein the first conductive plate takes a shape of an internal saucer.
- 20
- Embodiment 106. The apparatus of any of Embodiments 101 to 105, wherein the second conductive plate takes a shape from one or more parts of a surface of a sphere [e.g., a hemisphere, part of a hemisphere, a band formed along a sphere, two bands formed along a sphere, three (or four, five, or six...) bands formed along a sphere, a sphere cap and one or more bands, two or more concentric spherical bands, and concentric hemispheres].
- 25
- Embodiment 107. The apparatus of any of Embodiments 101 to 106, wherein the second conductive plate is located at least partially within a ledge of the ball-socket.
- 30
- Embodiment 108. The apparatus of any of Embodiments 101 to 107, wherein the first conductive plate and the second conductive plate take the form of opposing hemispheres (or partial spheres; see, e.g., Figure 15) or partial opposing hemispheres (or concave and convex hemispheres).

Embodiment 109. The apparatus of any of Embodiments 101 to 108, wherein the first  
conductive plate extends within a rod attached to the ball (not shown).

5 Embodiment 110. The apparatus of any of Embodiments 101 to 109, wherein the second  
conductive plate extends within a rod attached to the ball-socket (not shown).

Embodiment 201. A method for wireless power transfer comprising:  
acquiring or fabricating any of the apparatuses from Embodiment 1 to Embodiment  
10;  
10 applying alternating current to either the first conductive winding or the second  
conductive winding to transfer power via inductive coupling or magnetic resonance.

Embodiment 202. A method for wireless power transfer comprising:  
acquiring or fabricating any of the apparatuses from Embodiment 101 to Embodiment  
15 110; and  
applying alternating current to either the first conductive winding or the second  
conductive winding to transfer power via inductive coupling or magnetic resonance.

Embodiment 203. A method for wireless power transfer comprising:  
20 acquiring or fabricating any of the apparatuses from Embodiment 1 to Embodiment  
10; and  
transferring power via capacitive coupling.

Embodiment 204. A method for wireless power transfer comprising:  
25 acquiring or fabricating any of the apparatuses from Embodiment 101 to Embodiment  
110; and  
transferring power via capacitive coupling.

30 It should be understood that the examples and embodiments described herein are for  
illustrative purposes only and that various modifications or changes in light thereof will be  
suggested to persons skilled in the art and are to be included within the spirit and purview of  
this application.

All patents, patent applications, provisional applications, and publications referred to or cited herein (including those in the “References” section) are incorporated by reference in their entirety, including all figures and tables, to the extent they are not inconsistent with the explicit teachings of this specification.

REFERENCES

- [1] N. Tesla, "Apparatus for transmitting electrical energy," U.S. Patent 1,119,732, Dec. 1, 1914.
- [2] Robert Lomas, *The man who invented the twentieth century – Nikola Tesla – Forgotten Genius of Electricity*. Headline 1999, ISBN 0 7472 6265 9, p. 146.
- [3] J. C. Schuder, H. E. Stephenson, and J. F. Townsend, "High level electromagnetic energy transfer through a closed chestwall," *IRE Int. Conv. Rec.*, pt.9, vol.9, pp. 119-126, 1961.
- [4] W. H. Ko, S. P. Liang, and C.D.F. Fung, "Design of rf-powered coils for implant instruments," *Med. Biol. Eng. Comput.*, vol. 15, pp. 634-640, 1977.
- [5] E. Hochmair, "System optimization for improved accuracy in transcutaneous signal and power transmission", *IEEE Trans. Biomedical Engineering*, vol. BME-31, no.2, pp. 177-186, Feb. 1984.
- [6] B. Choi, J. Nho, H. Cha, T. Ahn and S. Choi, "Design and implementation of low-profile contactless battery charger using planar printed circuit board windings as energy transfer device," *IEEE Trans. Industrial Electronics*, vol. 51, no. 1, pp. 140-147, Feb. 2004.
- [7] Y. Jang and M. M. Jovanovic, "A contactless electrical energy transmission system for portable-telephone battery chargers", *IEEE Trans. Industrial Electronics*, vol. 50, no. 3, pp. 520–527, Jun. 2003.
- [8] W.G. Hurley and J. Kassakian, "Induction heating of circular ferromagnetic plates", *IEEE Trans. Magnetics*, vol. 15, no. 4, pp. 1174-1181, Jul. 1979.
- [9] A.W. Green and J.T. Boys, "10 kHz inductively coupled power transfer-concept and control", in *Proc. ICPE-VSD*, 1994, pp. 694–699.

- [10] J.T. Boys, G.A. Covic and A.W. Green, "Stability and control of inductively coupled power transfer systems", in *Proc. Electric Power Applications*, 2000, vol. 147, no. 1, pp. 37–43.
- [11] J.T. Boys, A.P. Hu and G.A. Covic, "Critical Q analysis of a current-fed resonant converter for ICPT applications", *Electronics Letters*, vol. 36, no. 17, pp. 1440–1442, 2000.
- [12] G.A.J. Elliott, G.A. Covic, D. Kacprzak and J.T. Boys, "A New Concept: Asymmetrical Pick-Ups for Inductively Coupled Power Transfer Monorail Systems", *IEEE Trans. Magnetics*, vol. 42, no. 10, pp. 3389–3391, 2006.
- [13] M.L.G. Kissin, J.T. Boys and G.A. Covic, "Interphase Mutual Inductance in Polyphase Inductive Power Transfer Systems", *IEEE Trans. Industrial Electronics*, vol. 56, no. 7, pp. 2393–2400, 2009.
- [14] B. Choi, J. Nho, H. Cha, T. Ahn and S. Choi, "Design and implementation of low-profile contactless battery charger using planar printed circuit board windings as energy transfer device", *IEEE Trans. Industrial Electronics*, vol. 51, no. 1, pp. 140-147, Feb. 2004.
- [15] Y. Jang and M. M. Jovanovic, "A contactless electrical energy transmission system for portable-telephone battery chargers", *IEEE Trans. Industrial Electronics*, vol. 50, no. 3, pp. 520–527, Jun. 2003.
- [16] C.-G. Kim, D.-H. Seo, J.-S. You, J.-H. Park and B. H. Cho, "Design of a contactless battery charger for cellular phone", *IEEE Trans. Industrial Electronics*, vol. 48, no. 6, pp. 1238-1247, Dec. 2001.
- [17] S.Y.R. Hui and W.C. Ho, "A new generation of universal contactless battery charging platform for portable Consumer Electronic equipment", *IEEE Trans. Power Electronics*, vol. 20, no. 3, pp. 620–627, May 2005.
- [18] X. Liu and S.Y.R. Hui, "Simulation Study and Experimental Verification of a Contactless Battery Charging Platform with Localized Charging Features" *IEEE Trans. Power Electronics*, vol. 22, no.6, pp. 2202–2210, Nov. 2007.

- [19] S.Y.R. Hui, "Planar Inductive Battery Charging System", US Patent 7,576,514, 2009.
- [20] Wireless Power Consortium Website [online]. Available:  
<http://www.wirelesspowerconsortium.com>
- [21] Yeongrack Son and Jung-Ik Ha, "The Electric Variable Transmission without Slip Ring for the Hybrid Electric Vehicle Driving Structure", 9th International Conference on Power Electronics-ECCE Asia, June 1 - 5, 2015, Convention Center, Seoul, Korea
- [22] Pekka Eskelinen, "Experimental Rotary Transformers For Antenna Power Supplies and Control", IEEE Antennas and Propagation Magazine, Vol. 52, No.5, October 2010, 165-167

## CLAIMS

What is claimed is:

1. An apparatus for wireless power transfer comprising:  
a ball including a first conductive winding; and  
a ball-socket including a second conductive winding,  
wherein the first conductive winding is electrically isolated from the second  
conductive winding.
2. The apparatus according to claim 1, wherein the first conductive winding takes a  
shape of one or more parts of a surface of a sphere.
3. The apparatus according to claim 1, wherein the first conductive winding takes a  
shape of a hemisphere.
4. The apparatus according to claim 1, wherein the first conductive winding takes a  
shape a spherical band.
5. The apparatus according to claim 1, wherein the first conductive winding takes a  
shape of a hemispherical cap and a hemispherical band.
6. The apparatus according to claim 1, wherein the first conductive winding takes a  
shape of two or more concentric hemispherical bands.
7. The apparatus according to claim 1, wherein the first conductive winding and the  
second conductive winding form of opposing partial or complete hemispheres.
8. The apparatus according to claim 1, wherein the second conductive winding is  
located partially or completely within a ledge of the ball-socket.
9. The apparatus according to claim 1, wherein the first conductive winding extends  
within a rod attached to the ball.

10. The apparatus according to claim 1, wherein the first conductive winding is planar equatorial.

11. An apparatus for wireless power transfer comprising:  
a ball including a first conductive plate; and  
a ball-socket including a second conductive plate,  
wherein the first conductive plate is electrically isolated from the second conductive plate.

12. The apparatus according to claim 11, wherein the first conductive plate takes a shape of one or more parts of a surface of a sphere.

13. The apparatus according to claim 11, wherein the first conductive plate takes a shape of a hemisphere.

14. The apparatus according to claim 11, wherein the first conductive plate takes a shape a spherical band.

15. The apparatus according to claim 11, wherein the first conductive plate takes a shape of a hemispherical cap and a hemispherical band.

16. The apparatus according to claim 11, wherein the first conductive plate takes a shape of two or more concentric hemispherical bands.

17. The apparatus according to claim 11, wherein the first conductive plate and the second conductive plate form of opposing partial or complete hemispheres.

18. The apparatus according to claim 11, wherein the second conductive plate is located partially or completely within a ledge of the ball-socket.

19. The apparatus according to claim 11, wherein the first conductive plate extends within a rod attached to the ball.

20. The apparatus according to claim 11, wherein the first conductive plate is planar equatorial.

21. A method for wireless power transfer comprising:  
acquiring or fabricating an apparatus according to any of claims 1-10; and  
applying alternating current to either the first conductive winding or the second conductive winding to transfer power via inductive coupling or magnetic resonance.

22. A method for wireless power transfer comprising:  
acquiring or fabricating an apparatus according to any of claims 11-20; and  
applying alternating current to either the first conductive winding or the second conductive winding to transfer power via inductive coupling or magnetic resonance.

23. A method for wireless power transfer comprising:  
acquiring or fabricating an apparatus according to any of claims 1-10; and  
transferring power via capacitive coupling.

24. A method for wireless power transfer comprising:  
acquiring or fabricating an apparatus according to any of claims 11-20; and  
transferring power via capacitive coupling.

10

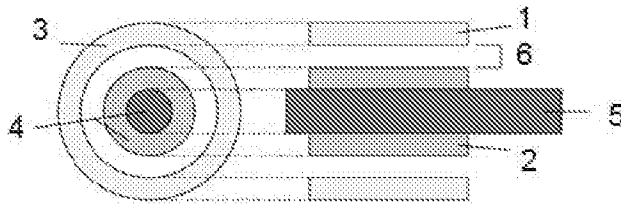

Prior Art

**Figure 1**

20

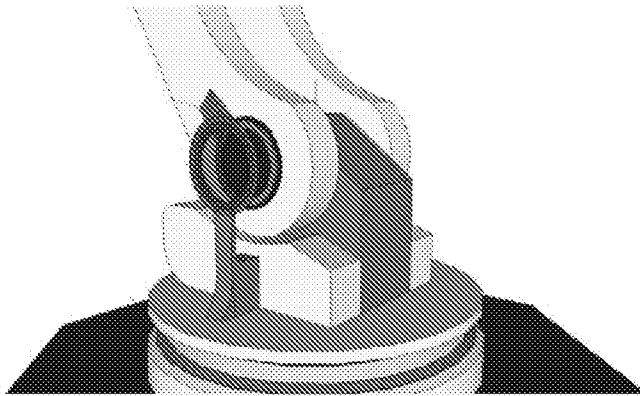

Prior Art

**Figure 2**

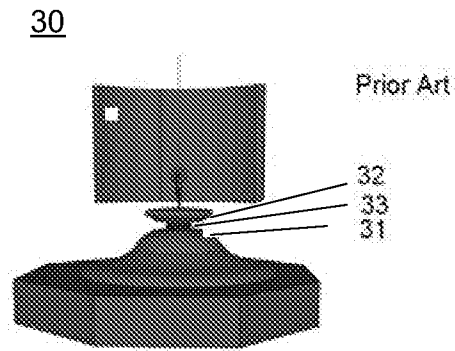

Figure 3

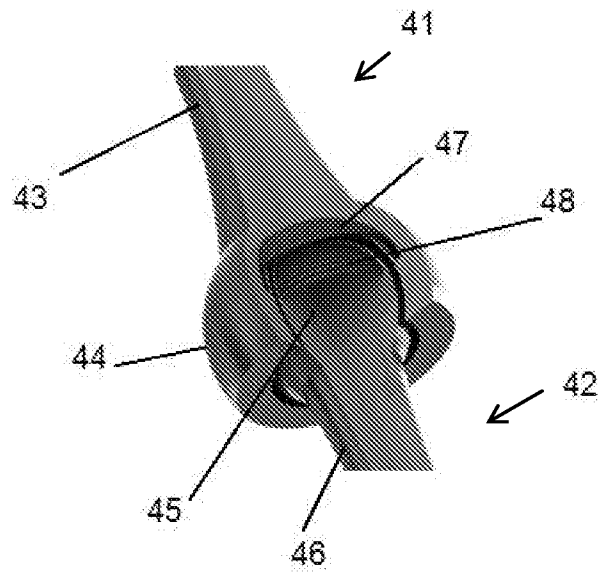

Figure 4A

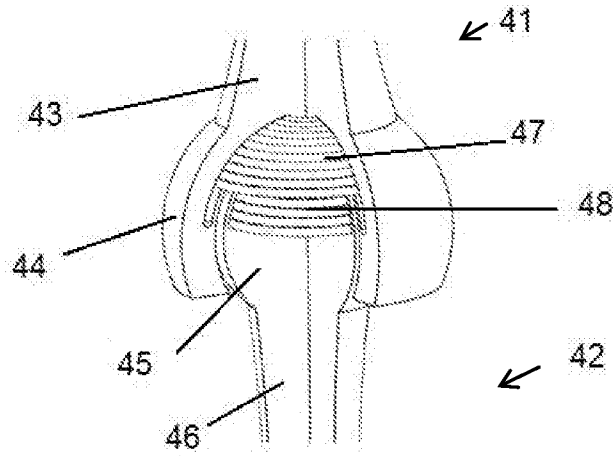

Figure 4B

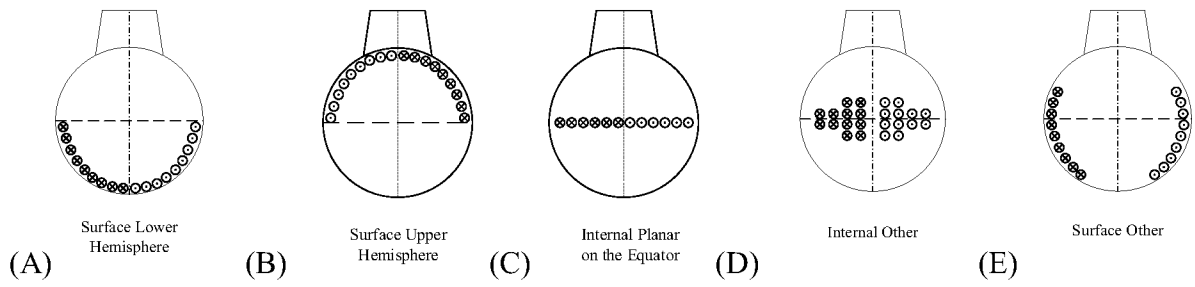

Figure 5

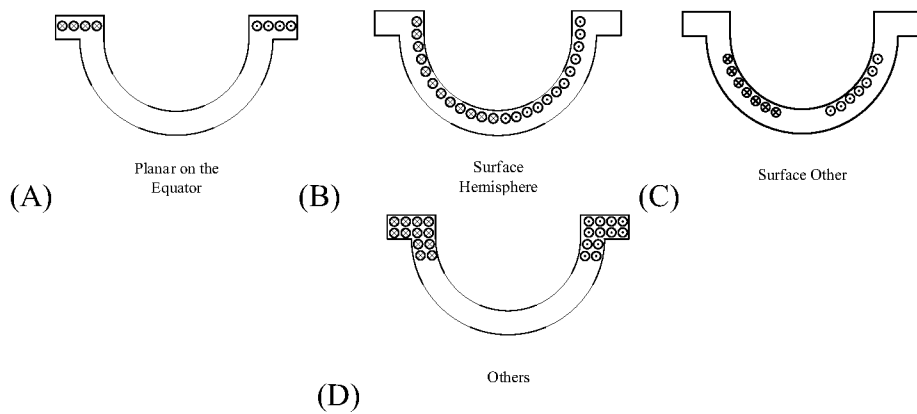

Figure 6

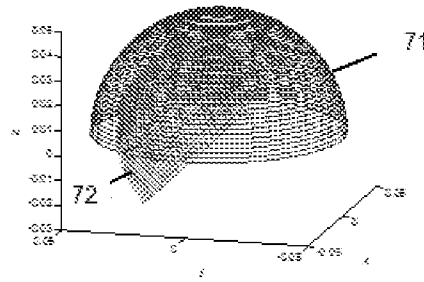

Figure 7

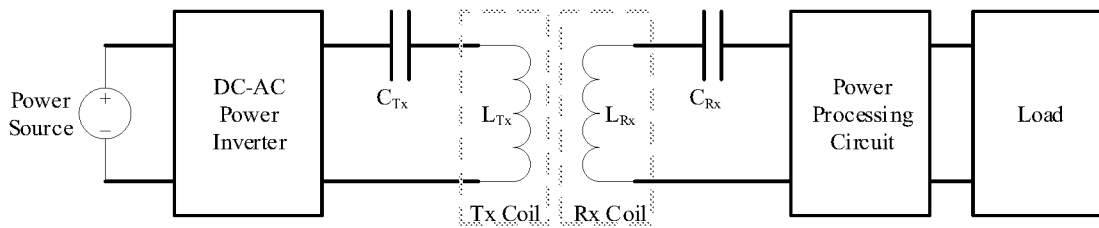

Figure 8

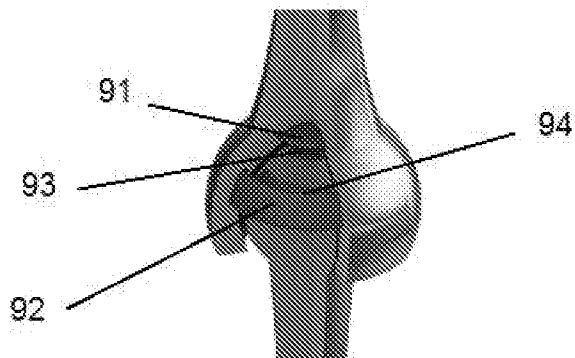

Figure 9A

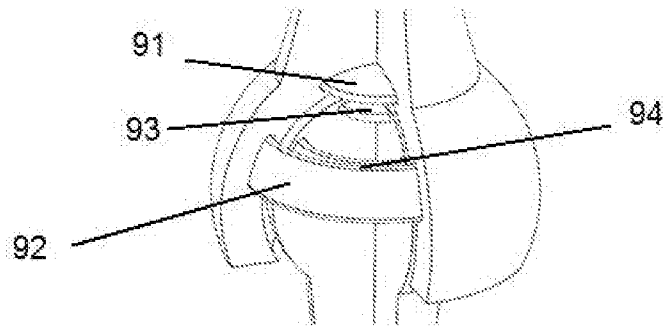

Figure 9B

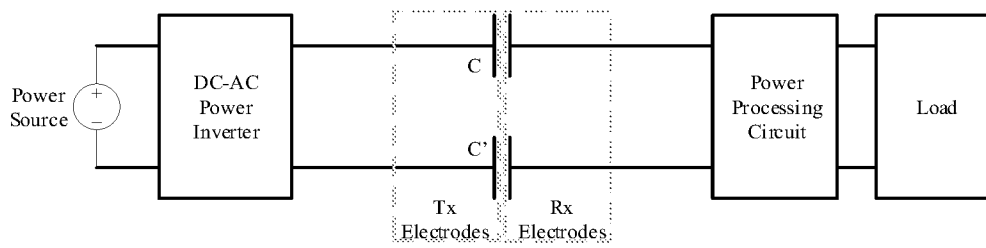

Figure 10

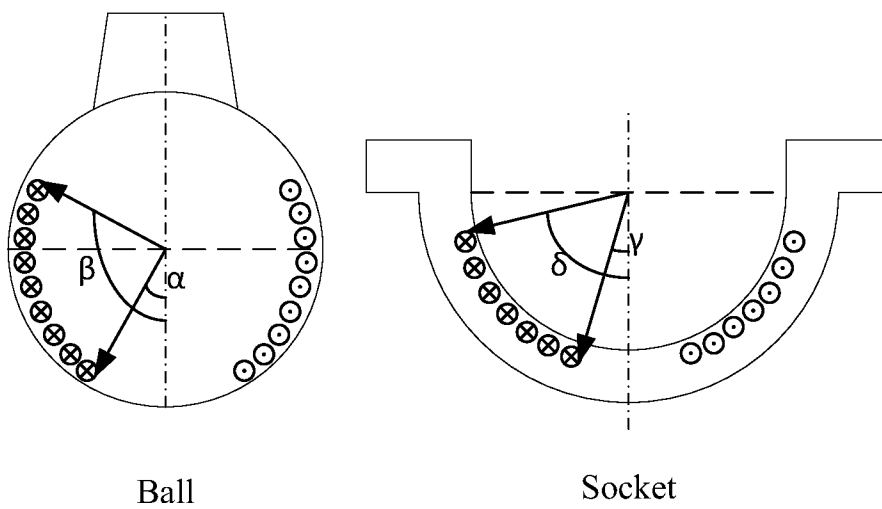

Figure 11

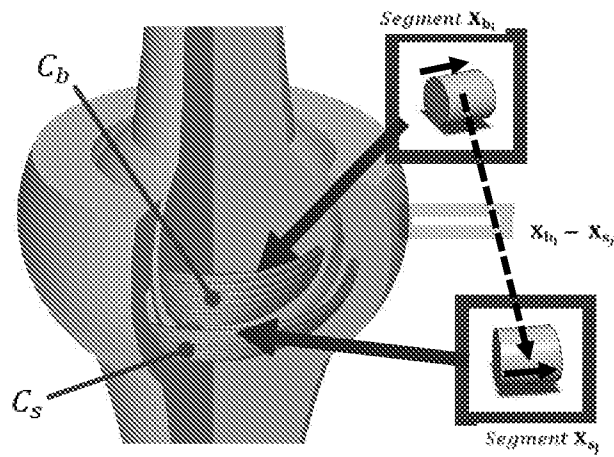

Figure 12

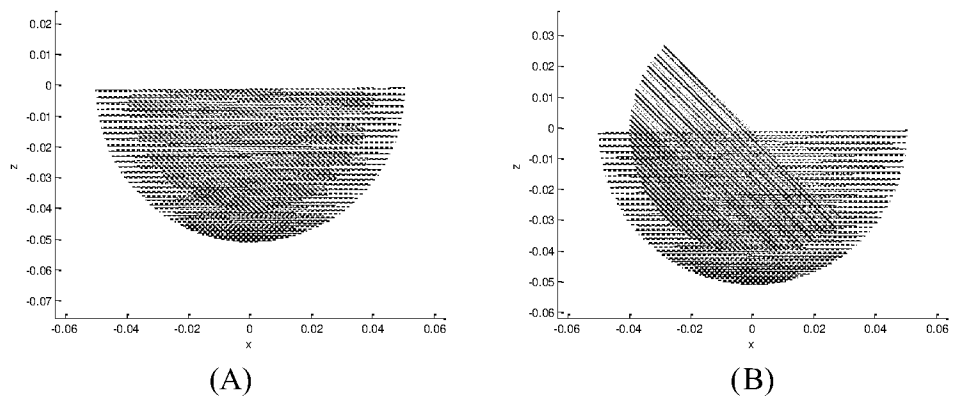

Figure 13

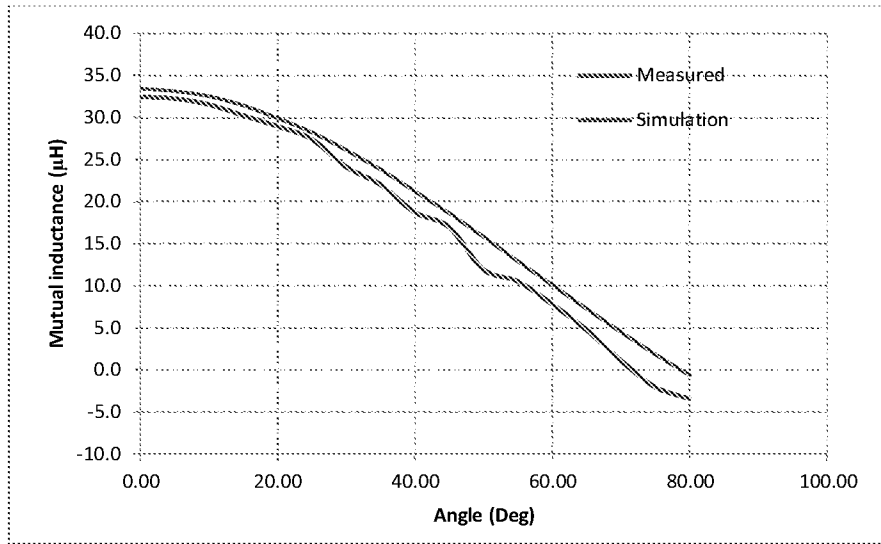

Figure 14

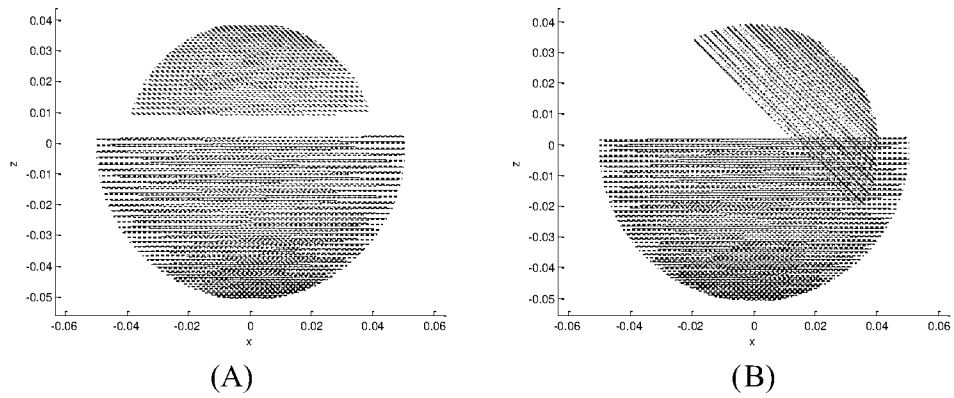
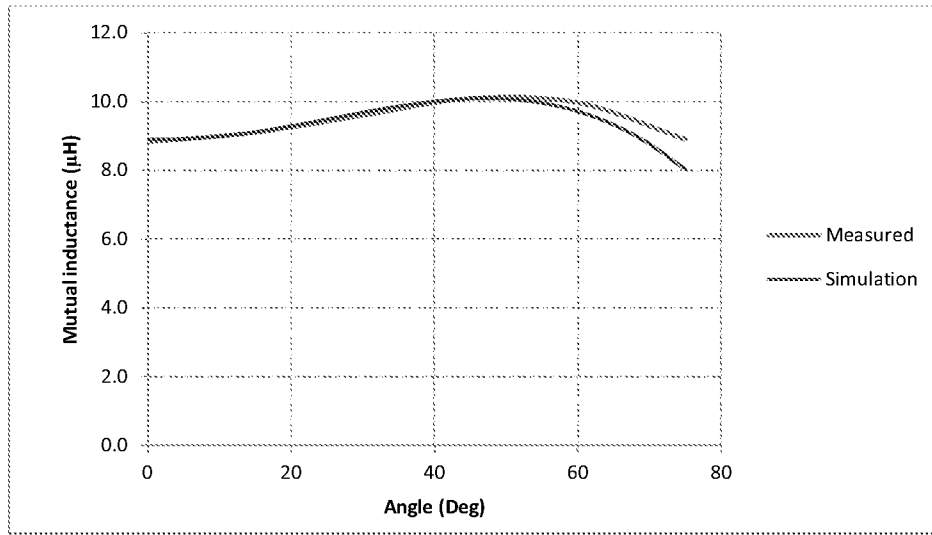
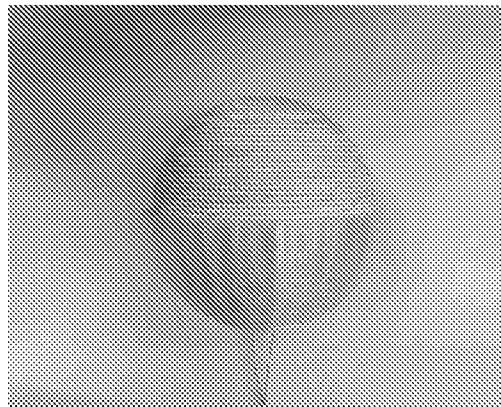

Figure 15



**Figure 16**



**Figure 17A**

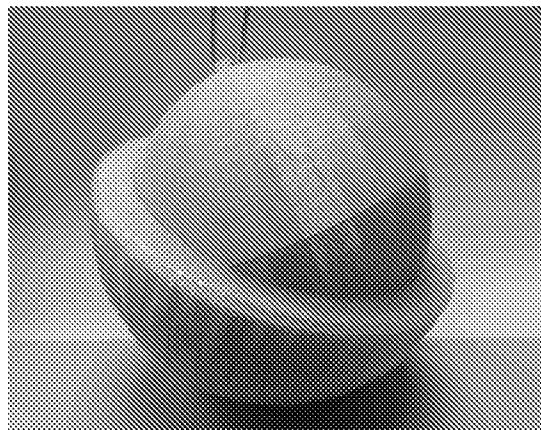

**Figure 17B**

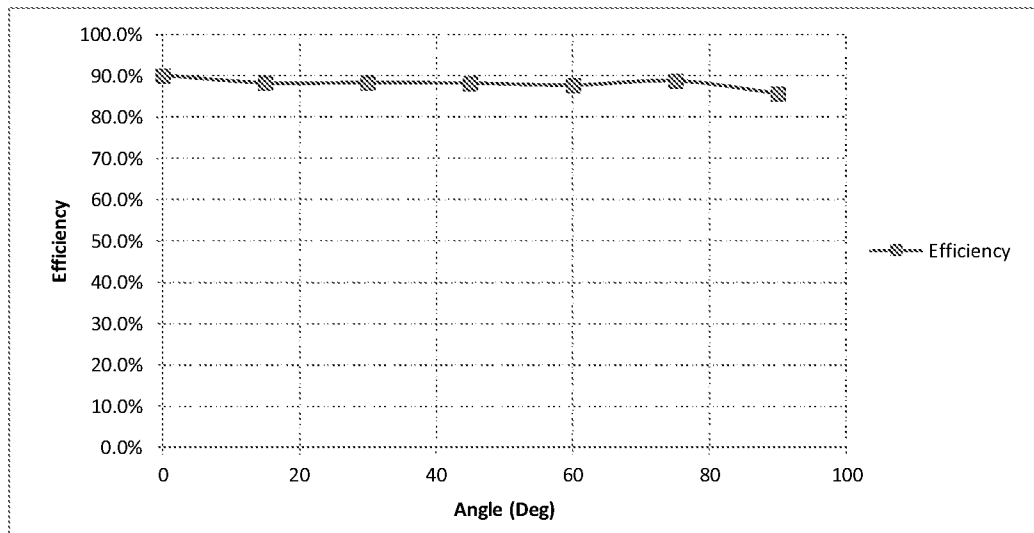

**Figure 18**

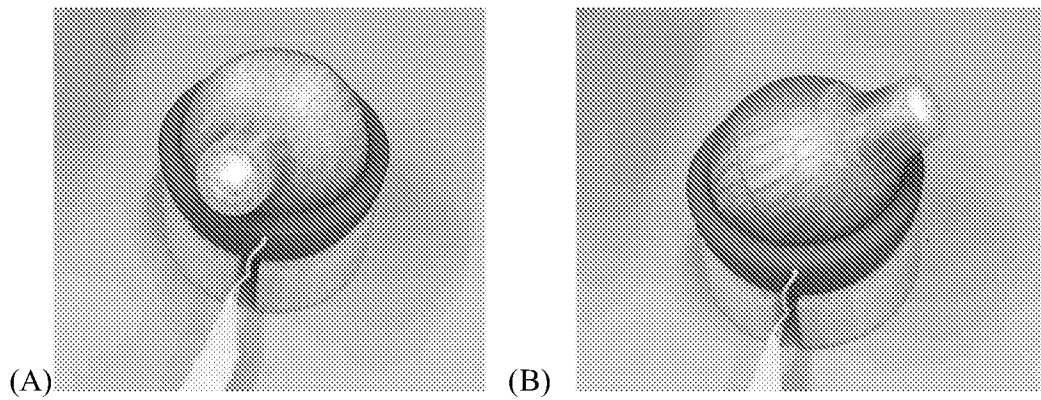

**Figure 19**

## INTERNATIONAL SEARCH REPORT

International application No.

PCT/CN2016/106366

**A. CLASSIFICATION OF SUBJECT MATTER**

H02J 7/00(2006.01)i; H02J 50/12(2016.01)i

According to International Patent Classification (IPC) or to both national classification and IPC

**B. FIELDS SEARCHED**

Minimum documentation searched (classification system followed by classification symbols)

H02J H04B

Documentation searched other than minimum documentation to the extent that such documents are included in the fields searched

Electronic data base consulted during the international search (name of data base and, where practicable, search terms used)

USTXT;CNTXT;CNABS;VEN:power, sphere, conductive, winding, socket,rod,spherical, wireless, transmitting, transfer+, transmission, hemisphere, groove, inductive,coupl+,magnetic,resonance,capacitive,planer,equatorial,band,ball

**C. DOCUMENTS CONSIDERED TO BE RELEVANT**

Category*	Citation of document, with indication, where appropriate, of the relevant passages	Relevant to claim No.
X	CN 203434708 U (GUANGZHOU XIAOWA INTELLIGENT TECHNOLOGY CO LTD) 12 February 2014 (2014-02-12) description paragraphs [0018]-[0029], claims 1-9, figures 1-3	1, 6-11, 16-24
Y	CN 203434708 U (GUANGZHOU XIAOWA INTELLIGENT TECHNOLOGY CO LTD) 12 February 2014 (2014-02-12) description paragraphs [0018]-[0029], claims 1-9, figures 1-3	2-5, 12-15
Y	CN 105846552 A (ZHONG HUI POWERISE WIRELESS POWER TECH LTD) 10 August 2016 (2016-08-10) claims 1-7, figures 1-5	2-5, 12-15
A	CN 104267831 A (HARBIN INST TECHNOLOGY) 07 January 2015 (2015-01-07) the whole document	1-24
A	US 8487479 B2 (COOK NIGEL PET AL.) 16 July 2013 (2013-07-16) the whole document	1-24
A	US 2013127253 A1 (STARK JOSEPH ET AL.) 23 May 2013 (2013-05-23) the whole document	1-24

 Further documents are listed in the continuation of Box C. See patent family annex.

\* Special categories of cited documents:

"A" document defining the general state of the art which is not considered to be of particular relevance

"E" earlier application or patent but published on or after the international filing date

"L" document which may throw doubts on priority claim(s) or which is cited to establish the publication date of another citation or other special reason (as specified)

"O" document referring to an oral disclosure, use, exhibition or other means

"P" document published prior to the international filing date but later than the priority date claimed

"T" later document published after the international filing date or priority date and not in conflict with the application but cited to understand the principle or theory underlying the invention

"X" document of particular relevance; the claimed invention cannot be considered novel or cannot be considered to involve an inventive step when the document is taken alone

"Y" document of particular relevance; the claimed invention cannot be considered to involve an inventive step when the document is combined with one or more other such documents, such combination being obvious to a person skilled in the art

"&amp;" document member of the same patent family

Date of the actual completion of the international search

26 July 2017

Date of mailing of the international search report

09 August 2017

Name and mailing address of the ISA/CN

STATE INTELLECTUAL PROPERTY OFFICE OF THE  
P.R.CHINA  
6, Xitucheng Rd., Jimen Bridge, Haidian District, Beijing  
100088  
China

Authorized officer

ZHANG,Xiaohui

Facsimile No. (86-10)62019451

Telephone No. (86-10)62411321

**INTERNATIONAL SEARCH REPORT**  
**Information on patent family members**

International application No.

**PCT/CN2016/106366**

Patent document cited in search report			Publication date (day/month/year)	Patent family member(s)			Publication date (day/month/year)
CN	203434708	U	12 February 2014	None			
CN	105846552	A	10 August 2016	None			
CN	104267831	A	07 January 2015	None			
US	8487479	B2	16 July 2013	US	2009224608	A1	10 September 2009
US	2013127253	A1	23 May 2013	AU	2012340918	A1	12 June 2014
				CA	2856283	A1	30 May 2013
				US	2016067396	A1	10 March 2016
				JP	2014534804	A	18 December 2014
				AU	2012340918	B2	14 July 2016
				US	9079043	B2	14 July 2015
				WO	2013078092	A1	30 May 2013
				EP	2782641	A1	01 October 2014