

May 7, 1968

G. P. SMITH

3,382,158

WIPE FILM MOLECULAR STILL

Filed April 1, 1966

3 Sheets-Sheet 1

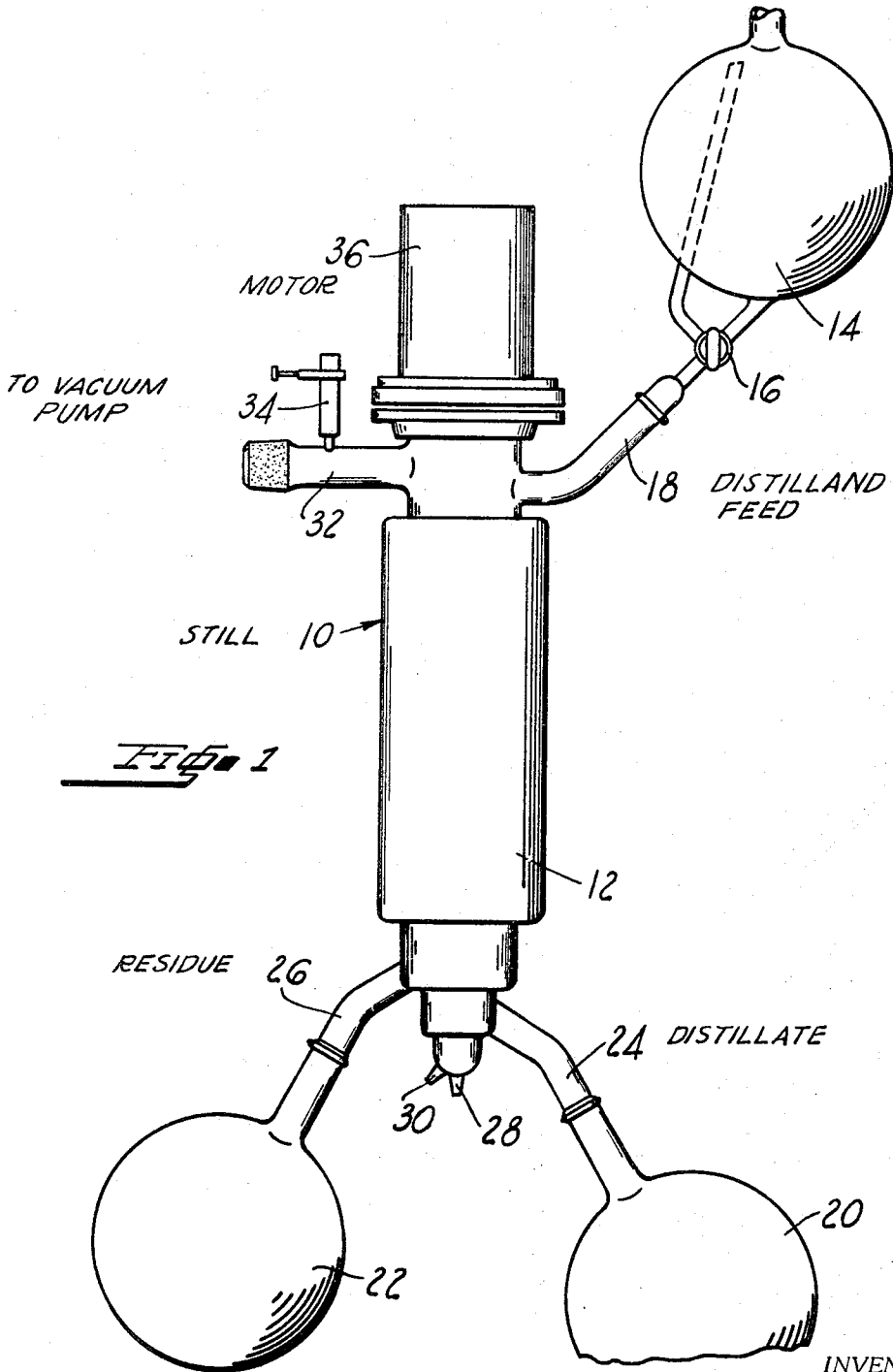

INVENTOR.
GEORGE P. SMITH
BY
W. S. Thompson
ATTORNEY

May 7, 1968

G. P. SMITH

3,382,158

WIPED FILM MOLECULAR STILL

Filed April 1, 1966

3 Sheets-Sheet 2

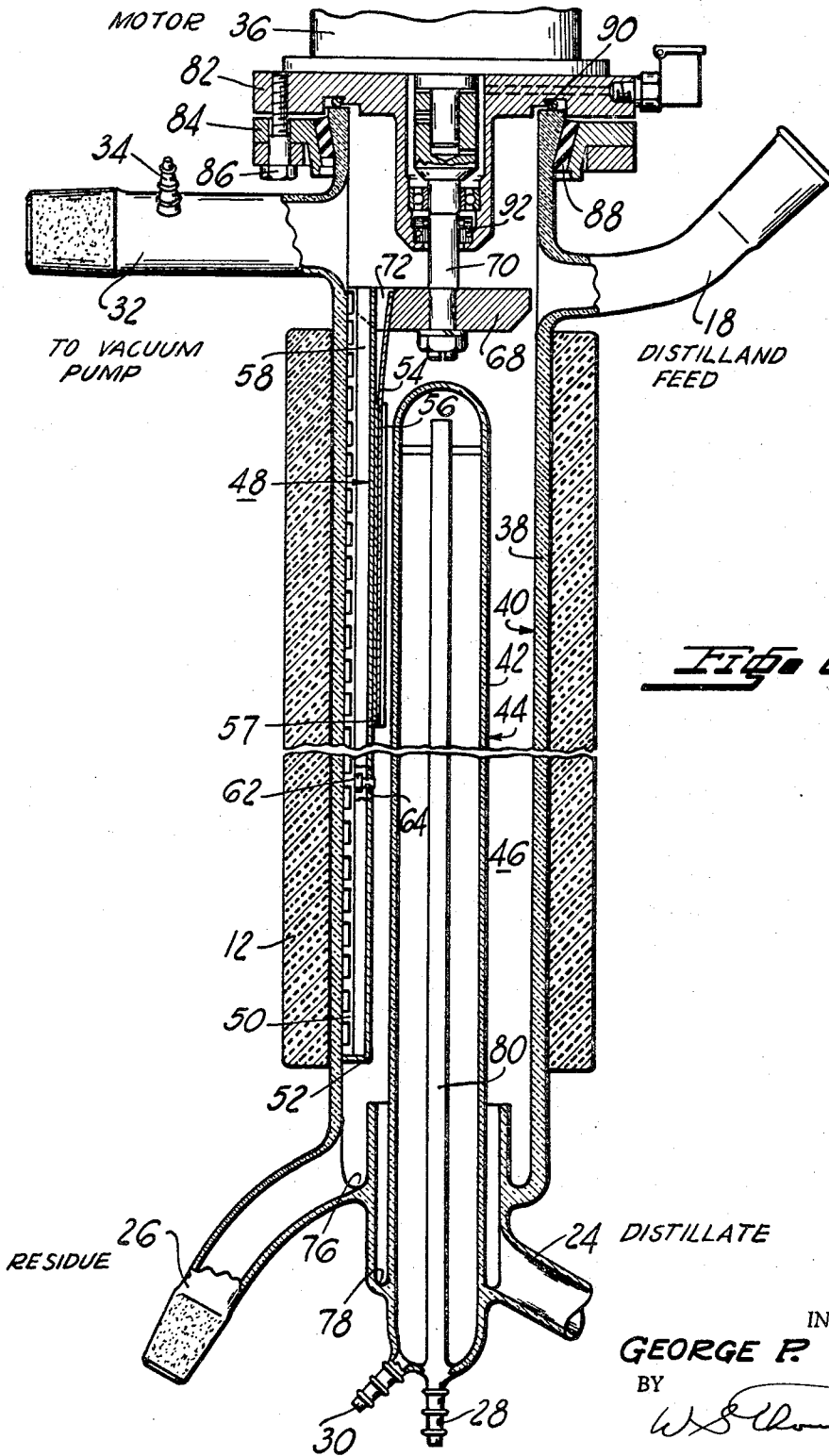

FIG. 2

INVENTOR
GEORGE P. SMITH
BY

ATTORNEY

May 7, 1968

G. P. SMITH

3,382,158

WIPE FILM MOLECULAR STILL

Filed April 1, 1966

3 Sheets-Sheet 3

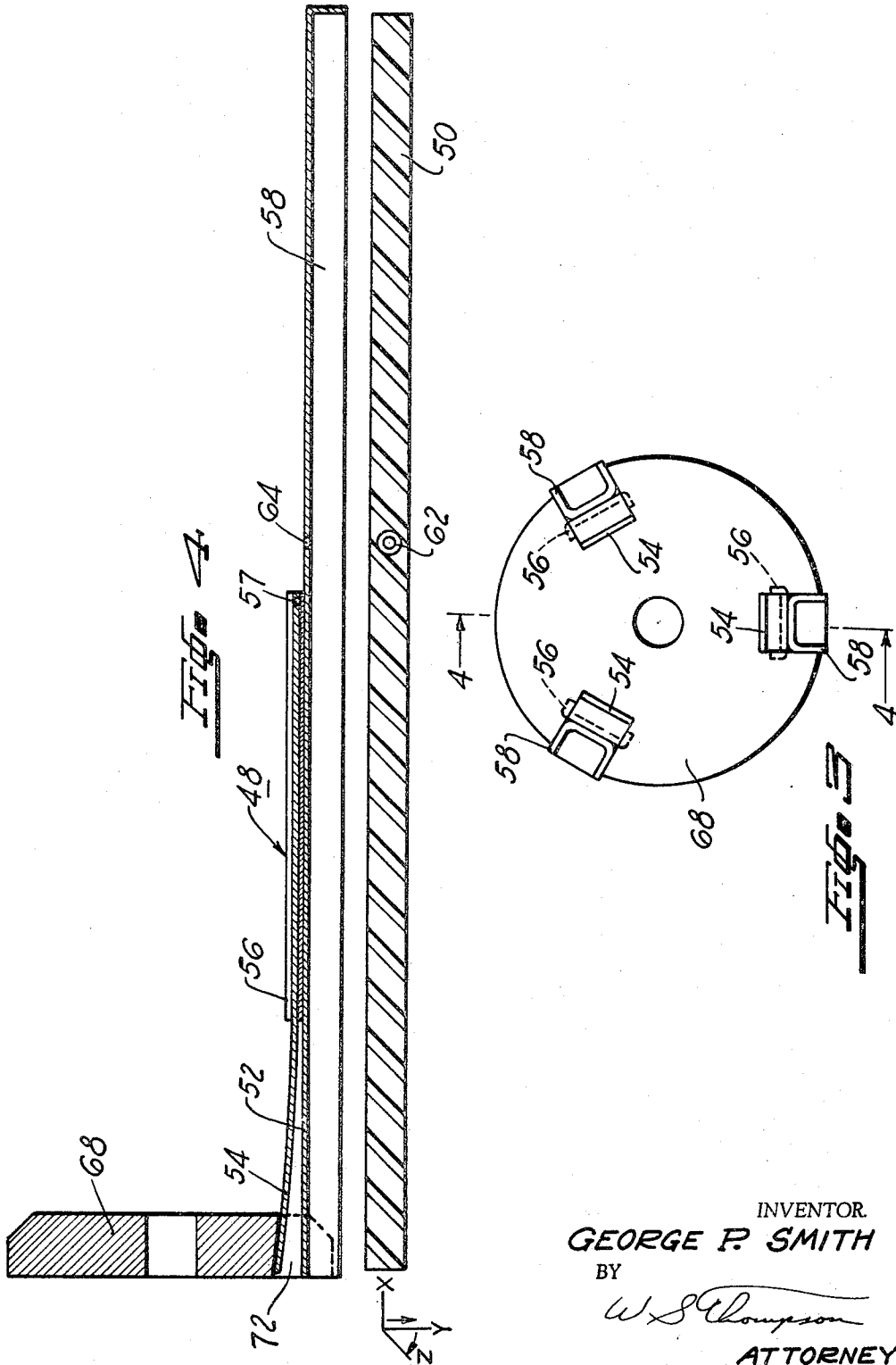

INVENTOR
GEORGE P. SMITH

BY

W. S. Thompson

ATTORNEY

1

3,382,158

WIPED FILM MOLECULAR STILL

George P. Smith, Rochester, N.Y., assignor, by mesne assignments, to The Bendix Corporation, Detroit, Mich., a corporation of Delaware

Filed Apr. 1 1966, Ser. No. 539,523

6 Claims. (Cl. 202-236)

ABSTRACT OF THE DISCLOSURE

A still which can separate heat sensitive materials and which includes novel film wiping means for reducing residence time and providing thin film distribution of the distilland over an evaporative surface which is concentric about a condensing surface. The wiping means make use of a leaf spring so that they apply a minimum pressure without necessary reliance on centrifugal force and have freedom of radial movement to the extent that placement of the axis of rotation is less critical, and the wiping means are also capable of limited axial pivoting about one point to compensate for inclination of the evaporating surface with respect to the axis of rotation of the wiping means.

The present invention relates to a wiped film molecular still which can separate heat sensitive materials and which particularly includes novel film wiping means for reducing residence time and provides thin film distribution of the distilland uniformly over the evaporative still surface.

In the past, many methods have been used to insure that the distilland material is distributed in a thin film over the evaporative surface in a still. One known means of accomplishing this is through the use of wiper blades which ride freely in guiding means and are thrown against the evaporation surface by the action of centrifugal force when the holding assembly is rotated. As the shaft of the assembly is rotated, the harder these wipers press against the evaporation surface, wiping the material to be distilled in a thin film to promote more easy evaporation.

Another method that has been used is to mount the blade from a shaft parallel to the evaporation surface such that when the rotor assembly is rotated at a sufficiently high speed, the wiper blade is swung out about its mounting axis by centrifugal force against the evaporation surface, thus wiping the material to be distilled into a thin film in order to promote easy evaporation of the material.

This latter approach has been successfully used with larger diameter evaporation surfaces. In these cases, the distance of the wiper blade surface from its mounting axis is sufficiently great that the centrifugal force obtained to rotate the blade surface into the evaporation surface is sufficient to satisfactorily wipe the evaporation surface. However, this design is not as satisfactory for smaller diameter stills as two things occur which prevent the proper operation of the wiper blades. First, the blades themselves become smaller and lighter; and second, the distance between the mounting axis of the blade and the working surface of the wiper blade becomes quite small. The direction of both of these changes is such as to reduce the magnitude of the forces pressing the wiper blade faces against the evaporation surface produced by the centrifugal force.

It is an object of the present invention to provide a wiper blade design for a molecular still which provides an effective film distributing minimum blade loading force apart from centrifugal loading forces.

It is another object of the present invention to provide a wiper blade assembly operative to readily conform to irregularities in the inclination or concentricity of the

2

evaporative surface wall to a much more effective degree than wiper blades known heretofore.

It is another object of the present invention to provide a wiper blade assembly which is simple in construction and which may efficiently be inserted and withdrawn into the still with a minimum of assembly difficulties.

Other objects and advantages of the present invention will become apparent on consideration of the description and attached drawings wherein:

FIGURE 1 is an external assembly view illustrating the general configuration of a preferred molecular still with which the wiper blade assembly of the present invention may be effectively utilized;

FIGURE 2 is a cross section view of the still proper showing the wiper blade assembly in its assembled position;

FIGURE 3 is a plan view of the rotor assembly of the present invention; and

FIGURE 4 is a cross sectional view taken along line 4-4 of FIGURE 3 illustrating our wiper blade mechanism in greater detail; the blade element has been oriented in exploded fashion and rotated 90 degrees to illustrate grooving.

Referring now to FIGURE 1, numeral 10 designates a generally-cylindrical still, which may be a relatively small diameter, which is encased in a heating mantle or jacket 12. The material to be distilled, or distilland, is contained in a flask or a reservoir 14 and fed by gravity through the stop cock 16 and inlet tubing 18 to the top end of still 10. Flask 20 is provided to receive the distillate products and flask 22 to receive the residue from the lower end of still 10 through tubing 24, 26 respectively. Water inlet fitting 28 and outlet fitting 30 are provided at the lower end of the still for circulating cooling liquid in the condenser section which will be later described. Fitting 32 is provided near the top end of the still to provide a connection with evacuating apparatus (not shown) such as high vacuum diffusion pump or the like. Branch fitting 34 provides a connection for a pressure recording apparatus. Mounted at the top end of the still and secured to the upper rim concentrically of the cylindrical still 10 is an electric motor 36 which provides a power driven means for the blade wiper assembly as will later be described in detail.

A cross sectional view of the still is illustrated in FIGURE 2, showing the inner mechanism which is comprised of an outer cylindrical wall 38, the inner surface of which provides an evaporative surface 40 and which is concentrically arranged and spaced radially outwardly of the tubular condenser member 42 which has a condensing surface 44. Intermediate the evaporative surface 40 and condensing surface 44 there is defined a generally cylindrical space 46 into which is disposed a plurality of blade wiper assemblies, one of which is illustrated in FIGURE 2 and designated generally by numeral 48. Each blade assembly consists of a grooved polytetrafluoroethylene wiper element 50, a metal backing member 52, and a leaf spring member 54 connected by a channel 56 pinned as at 57 to the metal backing member 52. The metal backing member 52 includes a channel wiper blade supporting channel 58 disposed on the side opposite spring 54. As best illustrated in FIGURE 4, wiper blade element 50 contains a hole 62 in alignment with hole 64 in the backing member to receive a fastening member such as a rivet or the like. A single fastening member is preferred to permit differential thermal expansion between the polytetrafluoroethylene wiper element and metal backing member. Backing member 52 contains a channel member 56 containing pin 57 for straddling each side of leaf spring 54 to maintain alignment between the wiper blade assembly and leaf spring. The Teflon blade element in FIGURE 4 is oriented in exploded fashion and rotated

90 degrees from backing member 50 as indicated by arrows and X-Y-Z reference at left end of blade.

A fixed blade disc rotor member 68 is mounted on rotatable motor shaft 70 and contains a plurality of radially-extending slots 72 notched inwardly from its outer periphery. Leaf spring members extend into the radial slots 72 wherein they are fixedly secured such as by welding or the like. The upper end of metal backing member 52 also extends into slots 72 and is free to move radially and axially within the slot. The connection between rotor 68 and leaf spring 54 and wiper blade assembly 48 is such as to provide a rotary driving connection while permitting relatively-free radial and axial movement of the backing member, rendering it capable of following variations in the inclination or eccentricity of the evaporative surface 40 and freely expand on exposure to high temperature.

At its lower end, the still 10 contains a residue collecting groove 76 and distillate collecting channel 78, each collecting the run-off from the evaporative surface 40 and condensing surface 44 respectively. Cooling water from water inlet 28 is conducted through tube 80 within condensing tube 42 and is collected through outlet passage 30. A continuous supply of cooling liquid is normally circulated to cool the condensing surface 44.

Motor 36 contains a mounting flange 82 which is connected to connecting ring 84 by means of bolts 86. Vacuum-tight packings 88, 90 and 92 are provided so that very low vacuums may be maintained in the still if desired.

The operation of the device is perhaps self-evident, but will be briefly described. The still is first evacuated and a controlled heat input applied through heating mantel 12 to establish the desired sub-atmospheric pressure and elevated temperature conditions required by a particular process. Motor 36 is turned on and stop cock 16 opened, permitting distilland to feed into the still by gravity where it comes in contact with the upper end of the evaporative surface 40. Rotating blades 50 distribute the distilland around the evaporating surface in a thin film and by means of angular grooves cut into the face of the wiper blades, accelerate the residence time of the distilland passing downwardly along the evaporative surface. As a constituent of the distilland vaporizes and leaves the evaporative surface 40, it fills the cylindrical space 46 and on striking condenser wall 44, it is cooled and condenses on that surface. The distillate then runs down the condenser wall 44 and into collecting channel 78 and is conducted from thence through connection 24 to the distillate flask 20. The residue in collecting channel 76 is conducted through connection 26 to the residue flask 22.

It will be apparent that even for a low rotating speed of motor 36 and small still diameter, leaf spring 54 is operative to provide a minimum biasing force, urging the wiper blades into contact with the evaporative surface wall. Furthermore, my blade device is operative to maintain effective wiping contact even if relatively large eccentricities exist between the cylindrical evaporative surface wall and motor rotative axis. Since the leaf spring 54 extends over a considerable span, it minimizes force reduction due to blade displacement.

It will be understood that while the device has particular utility in small stills wherein the centrifugal blade loading force is minimized, it may also be applied with advantage to larger stills as it is believed its simplicity of construction and ability to accommodate for eccentricities are

important assets which may be used with advantage on all still sizes.

I claim:

1. A wiped film molecular still comprising: still means having concentric evaporative and condensing surfaces defining a generally-cylindrical space therebetween; elongated wiper blade means extending into said cylindrical space and in abutting contact with said evaporative surface; a rotor member rotatably mounted in said still means and disposed at one end of said cylindrical space; said member having a radially extending slot notched inwardly from its outer periphery; a leaf spring member connected on one end to said rotor member and extending into said slot and projecting into said cylindrical space adjacent said wiper blade means, said leaf spring connected on its other end to said wiper blade means to provide a spring bias force urging said blade means into wiping contact with said evaporative surface; and said wiper blade means and said rotor being drivingly interconnected while permitting relative movement of said wiper blade means in a radial direction.

2. A wiped film molecular still as claimed in claim 1 including:

electric motor means connected to and providing a driving means for said rotor member, and said wiper blade means comprising a grooved blade element inserted in channeled metal backing member.

3. A wiped film molecular still as claimed in claim 2 wherein:

one end of said channeled metal backing member extends into said radially-extending slot to provide a rotational drive connection.

4. A wiped film molecular still as claimed in claim 1 wherein:

a hinge connection interconnects said leaf spring and said metal backing element to permit the wiper blade means to freely align to the inclination of the evaporative surface.

5. A wiped film molecular still as claimed in claim 4 wherein:

said hinge connection is disposed at substantially the midpoint of said wiper blade means.

6. A wiped film molecular still as claimed in claim 1 wherein:

said wiper blade means is comprised of a plurality of wiper blade units symmetrically arranged in a circumferential path each connected to said rotor member which provides a common drive member for all wiper blade units.

References Cited

UNITED STATES PATENTS

| | | | |
|-----------|---------|----------------|-----------|
| 2,993,842 | 7/1961 | Smith | 202—236 X |
| 3,004,901 | 10/1961 | Nerge et al. | 202—236 |
| 3,020,211 | 2/1962 | Smith | 202—236 X |
| 3,054,729 | 9/1962 | Smith | 202—236 |
| 3,058,516 | 10/1962 | Brunk | 159—6 |
| 3,060,107 | 10/1962 | Smith | 202—236 |
| 3,180,399 | 4/1965 | Belcher et al. | 159—6 |

NORMAN YUDKOFF, *Primary Examiner*.

F. E. DRUMMOND, *Examiner*.