



(19) **United States**

(12) **Patent Application Publication**

Zhu et al.

(10) **Pub. No.: US 2003/0081913 A1**

(43) **Pub. Date: May 1, 2003**

(54) **OPTICAL CONNECTOR WITH SLIDABLE SHIELDING DOOR**

(52) **U.S. Cl. .... 385/92**

(76) Inventors: **ZiQiang Zhu**, Kunsan (CN); **Guohua Zhang**, Kunsan (CN)

(57) **ABSTRACT**

Correspondence Address:  
**Wei Te (Joseph) Chung**  
**Foxconn International, Inc.**  
**1650 Memorex Drive**  
**Santa Clara, CA 95050 (US)**

A plastic optical fiber connector (3) includes a housing (32) defining a cavity (35) therein for receiving a complementary optical fiber plug (4), an active device (33) embedded in a rear of the housing, and a shielding door (31) disposed at a front of the housing. The shielding door includes two parallel slots (314) defined in opposite side walls (315) thereof, and a shaft (313) extending through the slots. Opposite ends of the shaft are fixed in a front portion of the housing. When the optical fiber plug is to be inserted into the cavity of the housing, the shielding door is manually rotated outwardly and upwardly from a closed position to an open position, and then slid into the housing. Once the optical fiber plug is withdrawn from the optical fiber connector, the shielding door is manually slid outwardly, and then rotat- ingly returned to its original closed position.

(21) Appl. No.: **10/020,534**

(22) Filed: **Dec. 13, 2001**

(30) **Foreign Application Priority Data**

Oct. 31, 2001 (TW)..... 90218617

**Publication Classification**

(51) **Int. Cl.<sup>7</sup> ..... G02B 6/42**

3

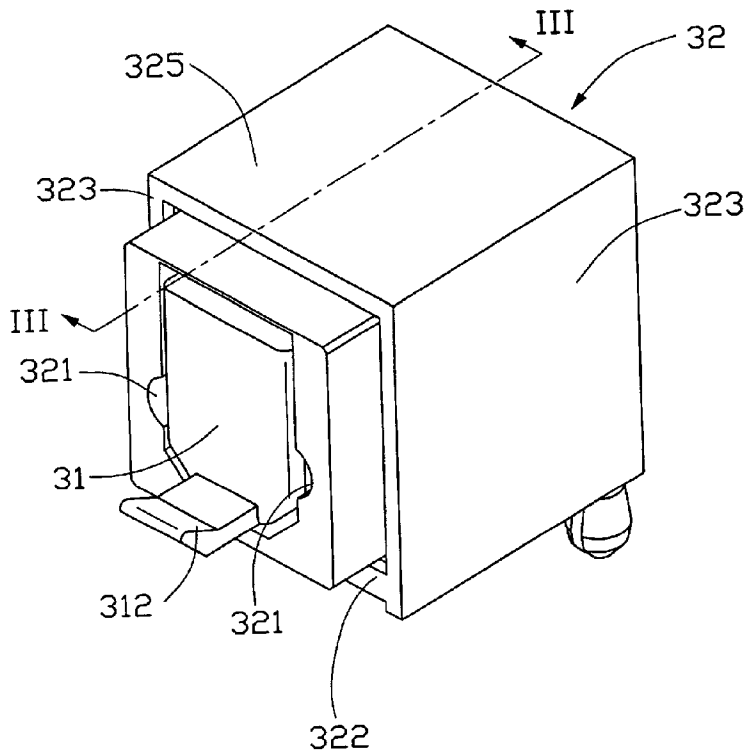

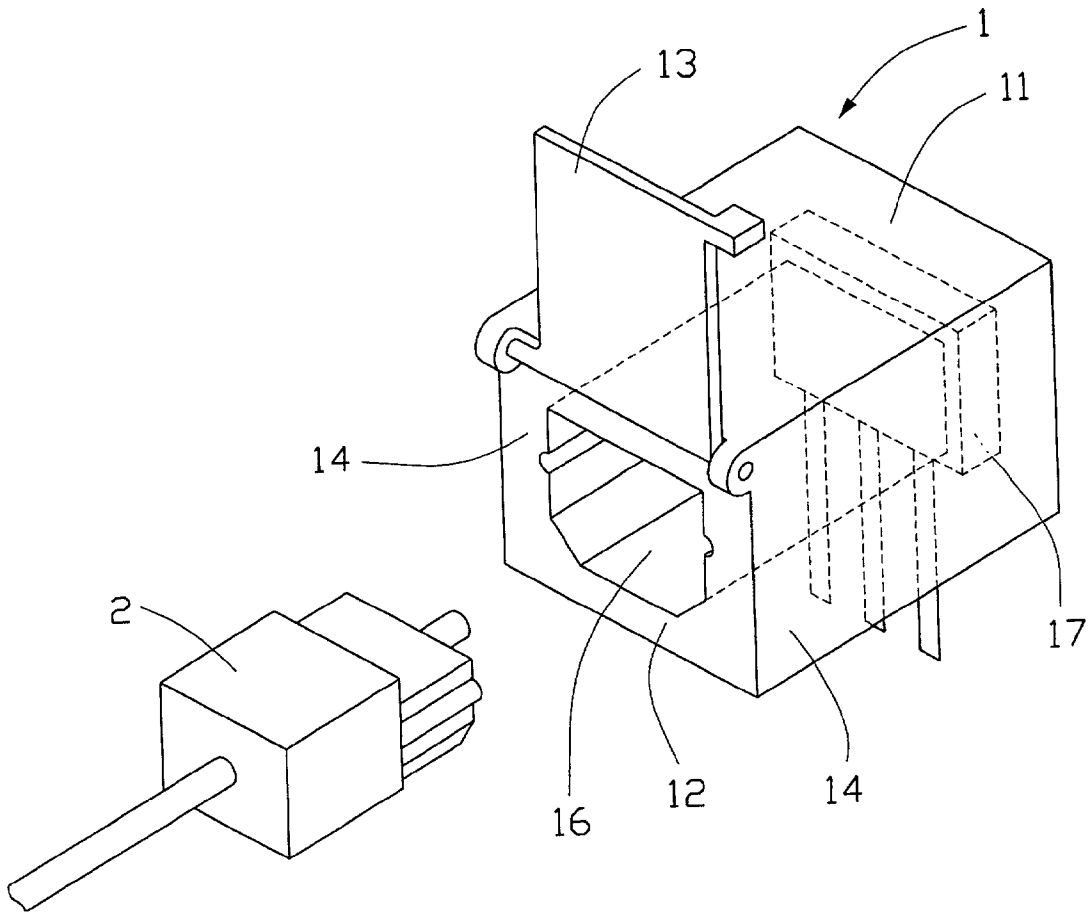

FIG. 1  
(PRIOR ART)

3

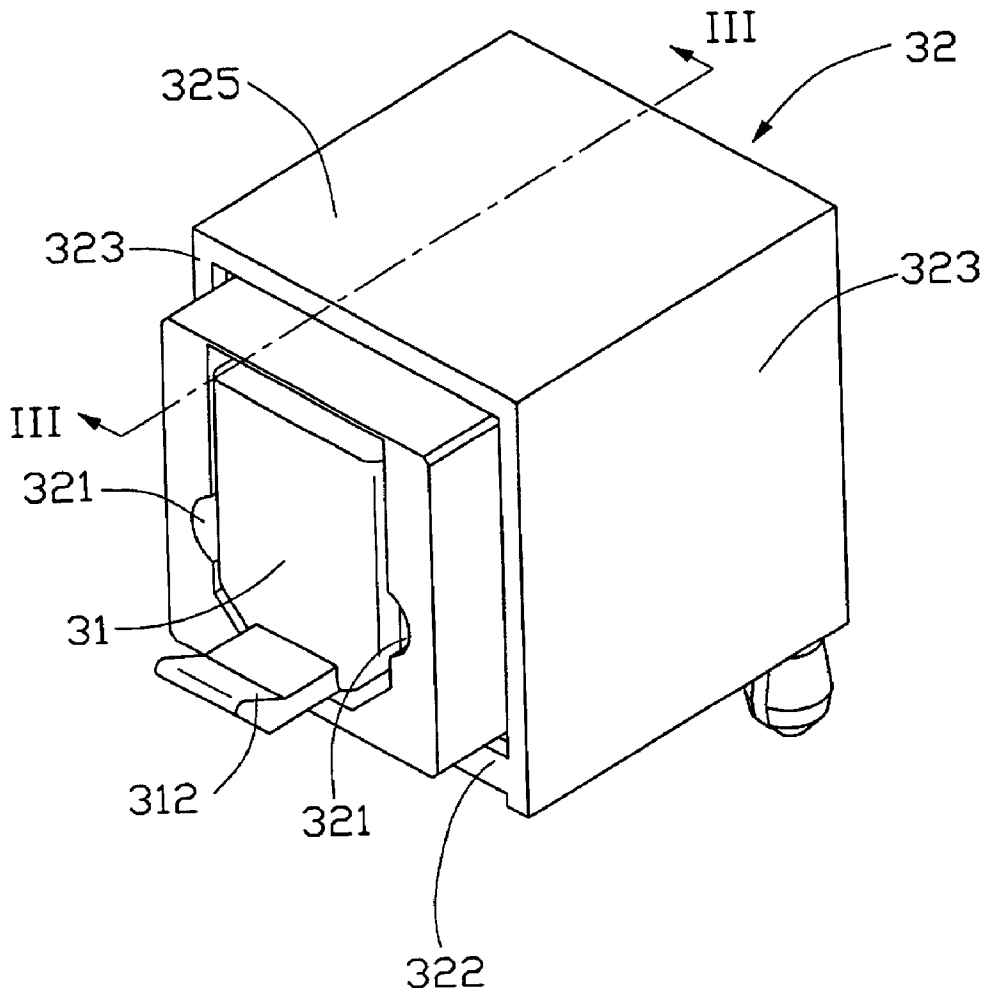

FIG. 2

3

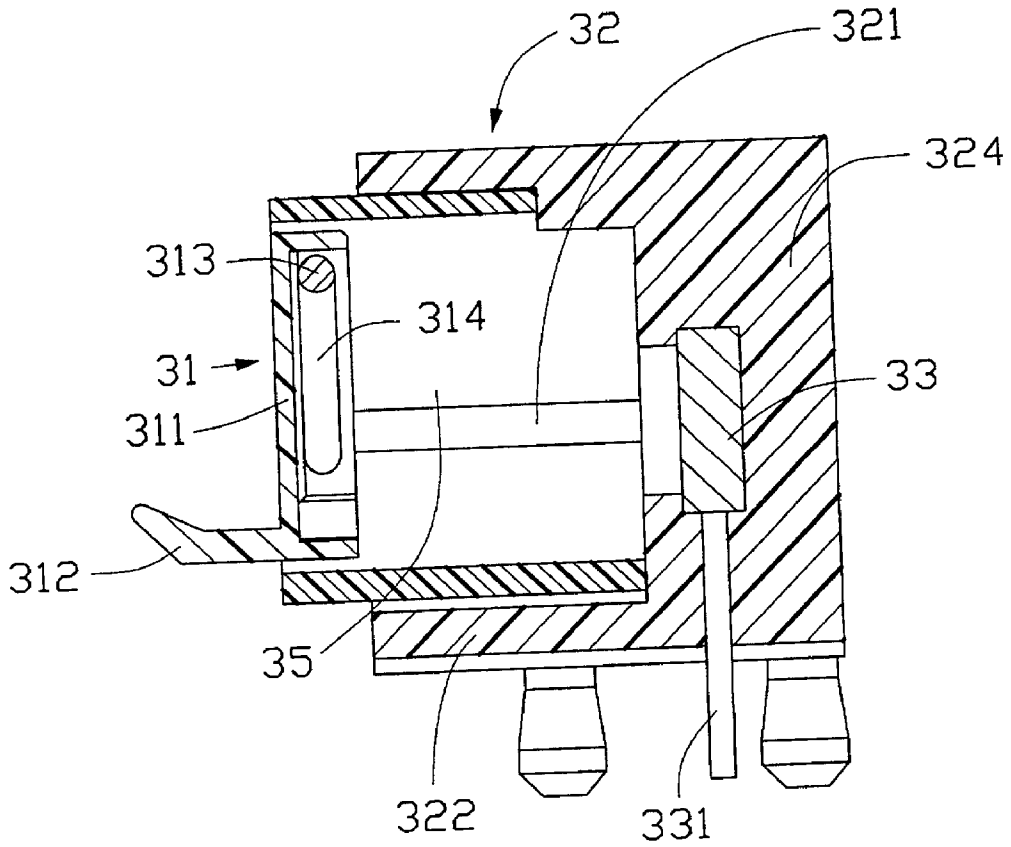

FIG. 3

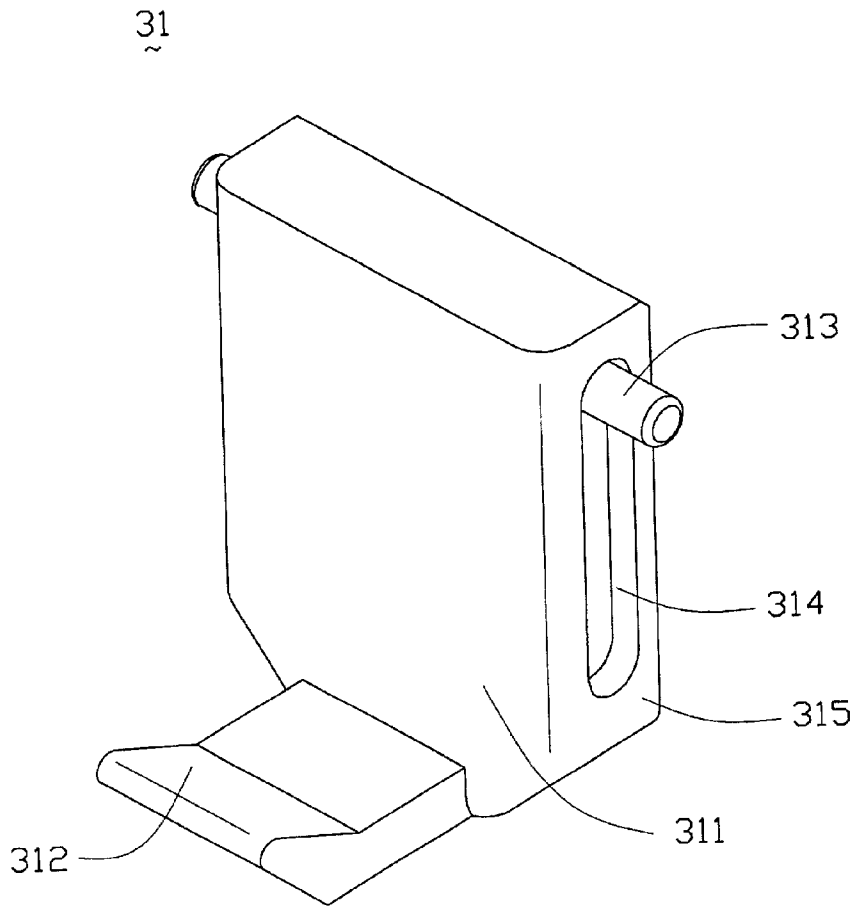

FIG. 4

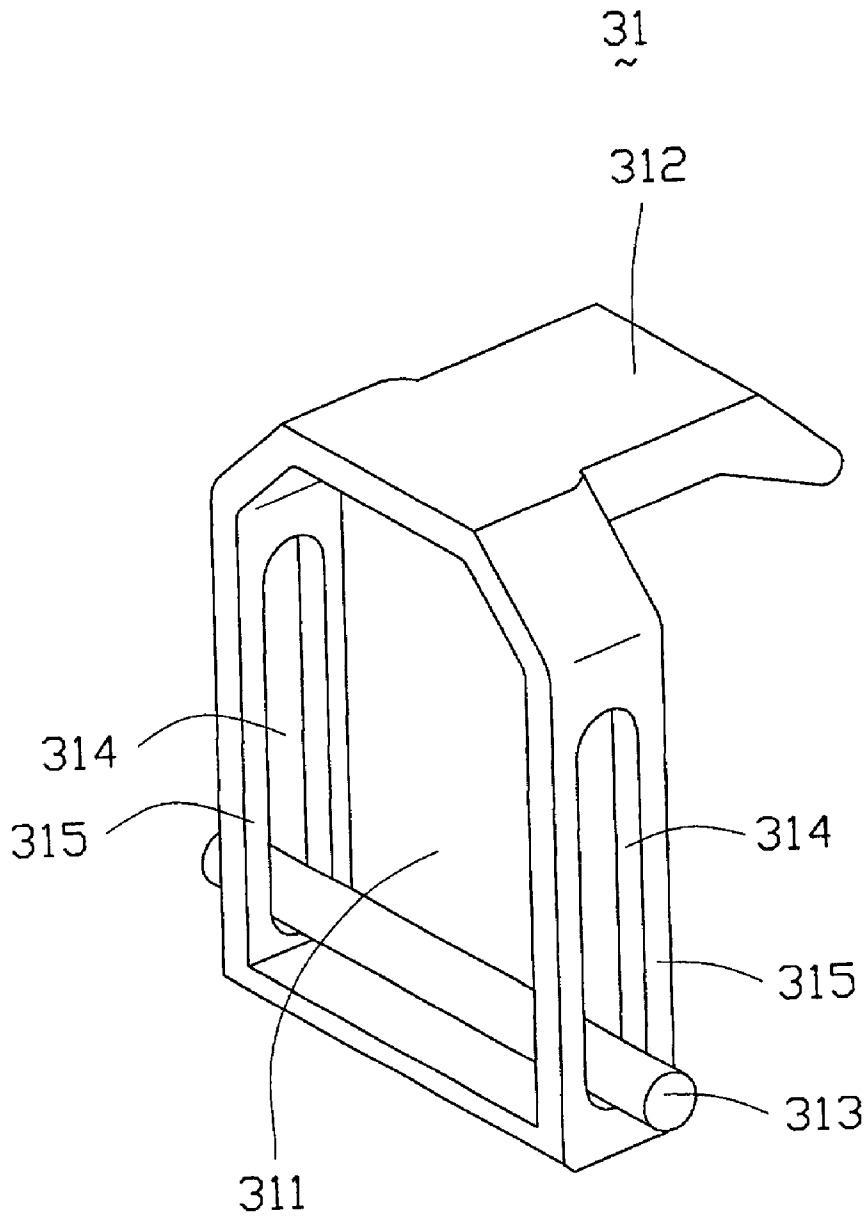

FIG. 5

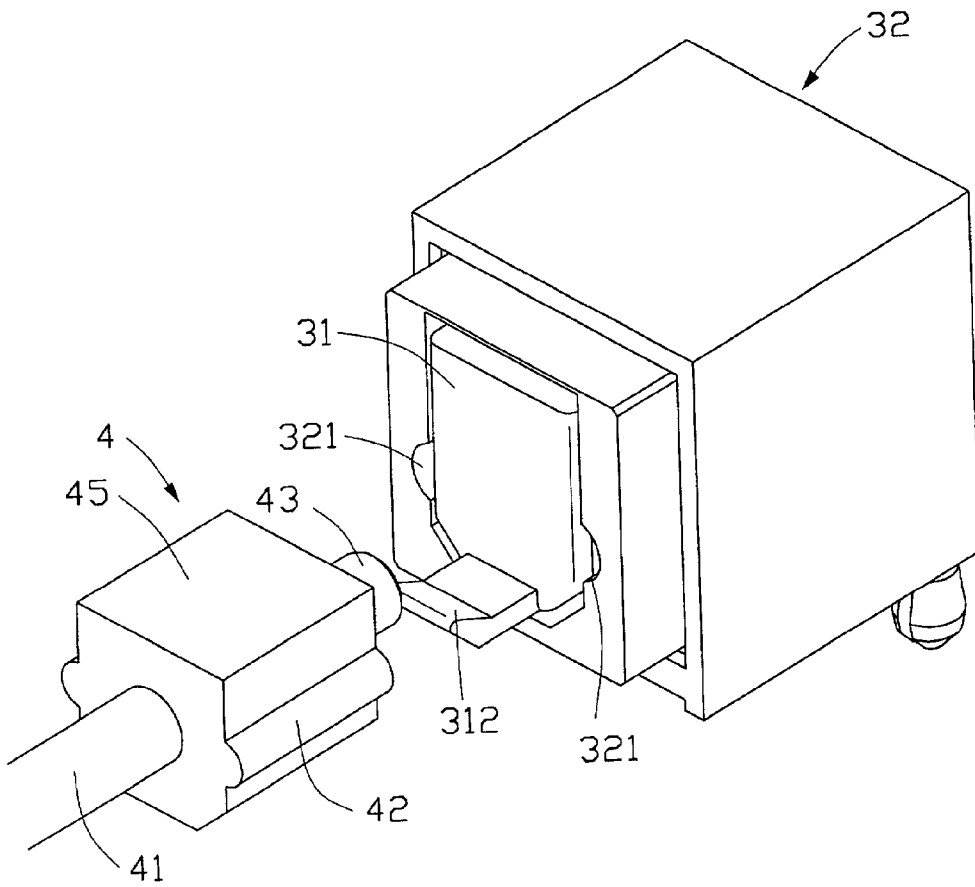

FIG. 6

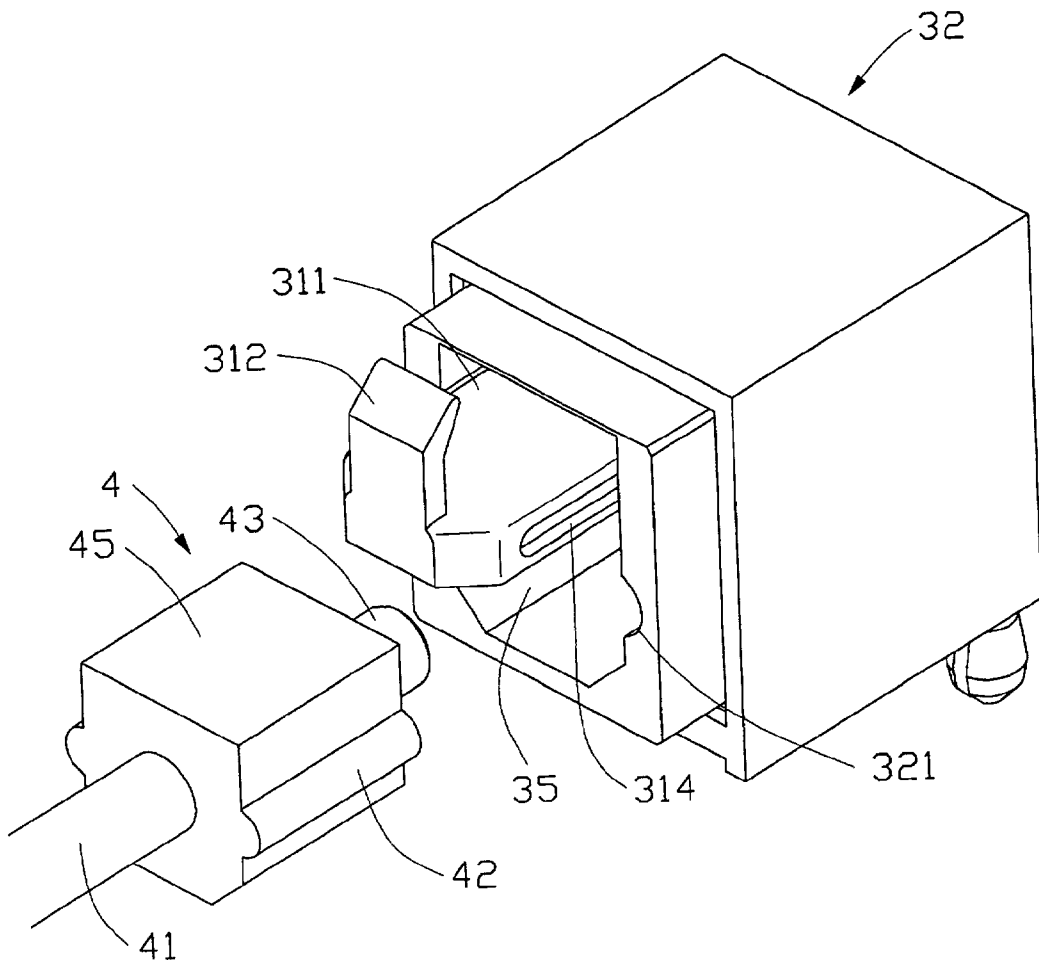

FIG. 7



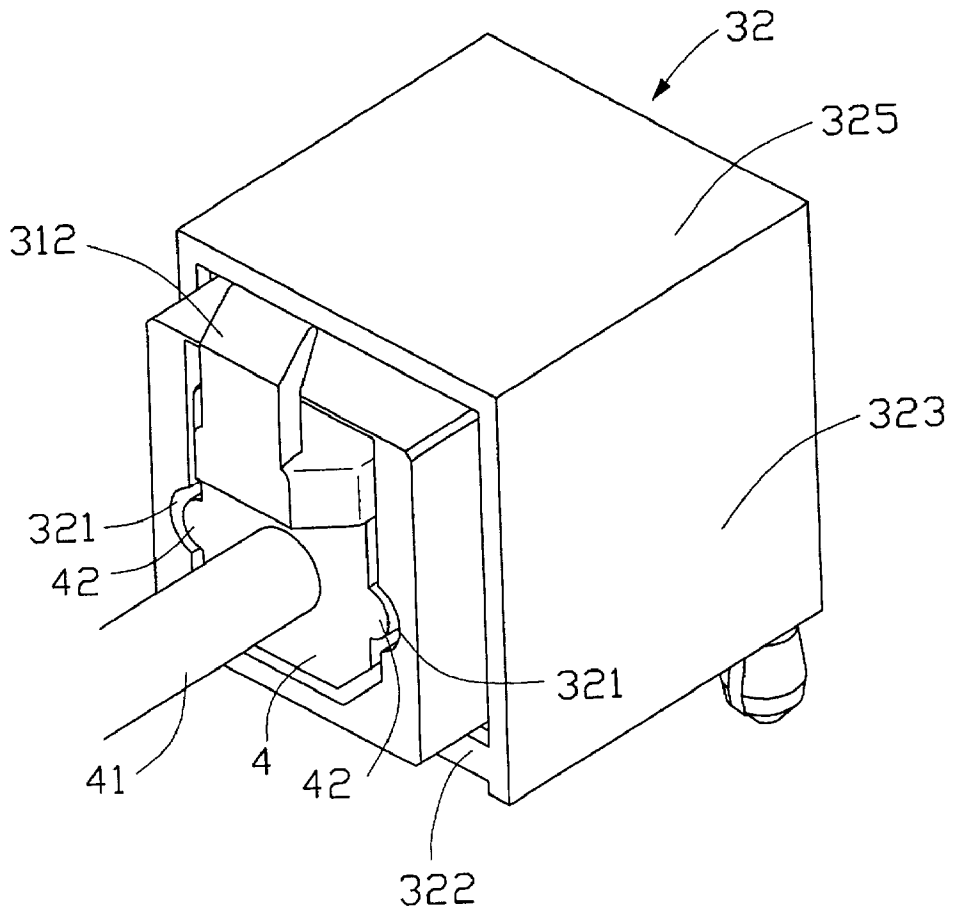

FIG. 8

## OPTICAL CONNECTOR WITH SLIDABLE SHIELDING DOOR

### BACKGROUND OF THE INVENTION

[0001] 1. Field of the Invention

[0002] The present invention relates to optical fiber receptacle connectors for receiving optical fiber plug connectors, and more particularly to a plastic optical fiber receptacle connector having a rotatable and slidable shielding door.

[0003] 2. Description of Prior Art

[0004] Optical fiber connectors are an important part of optical fiber communications systems. For instance, such connectors may be used as joints in long-distance optical fiber routing; to connect optical fibers to passive devices such as switches and attenuators; or to connect optical fibers to active devices such as radiation sources and detectors.

[0005] When an optical fiber connector is used for removably coupling an active device with an optical fiber plug, the optical fiber connector normally has a shielding door for preventing dust and other foreign matter from entering the optical fiber connector. Dust and other foreign matter adversely affect the performance of active devices inside the optical fiber connector.

[0006] FIG. 1 shows a plastic optical fiber connector disclosed in Japan Patent Application JP-A-6-331859. The plastic optical fiber connector comprises a housing 1 having a bottom wall 12, two sidewalls 14 extending upwardly from the bottom wall 12, a top wall 11, and a rear wall (not labeled) integrally connecting the top wall 11 and the sidewalls 14. A space 16 is defined in the housing 1 for receiving a complementary optical fiber plug 2. An active device 17 is embedded in the rear wall of the housing 1. A shielding door 13 is pivotably positioned at a front of the housing 1. Once an optical fiber plug 2 is withdrawn from the optical fiber connector, the shielding door 13 is closed to avoid entry of dust into the optical fiber connector. When the optical fiber plug 2 is inserted into the housing 1, the shielding door 13 is rotated to an open position. However, once the optical fiber plug 2 is received in the optical fiber connector, the shielding door 13 remains entirely outside the housing 1. As a result, an unduly large amount of space is occupied by the shielding door 13. Furthermore, the shielding door 13 is unduly exposed and prone to sustain accidental damage.

[0007] Another plastic optical fiber connector is disclosed in Japan Patent JP-2001-201663. The plastic optical fiber connector includes a housing, a shielding door, and a spring member mounted between the housing and the shielding door. When an optical fiber plug is inserted into the optical fiber connector, the shielding door is pushed open and the spring member is deformed. Spring force is thereby generated in the spring member and exerted on the shielding door. When the optical fiber plug is withdrawn from the optical fiber connector, the spring force of the spring member urges the shielding door to return to its original closed position. Unfortunately, the spring member is prone to break at a point where it interconnects with the shielding door, particularly after it has become fatigued from repeated use. The shielding door is thus easily damaged, and needs frequent replacement.

### SUMMARY OF THE INVENTION

[0008] In view of the above, an object of the present invention is to provide a plastic optical fiber connector having a durable shielding door which prevents contamination of optical devices inside the optical fiber connector.

[0009] Another object of the present invention is to provide a plastic optical fiber connector having a shielding door received in the optical fiber connector once an optical fiber plug is inserted into the optical fiber connector.

[0010] In order to achieve the objects set above, a plastic optical fiber connector in accordance with the present invention comprises a housing defining a cavity therein for receiving a complementary optical fiber plug, an active device embedded in a rear of the housing, and a shielding door disposed at a front of the housing. The shielding door comprises two parallel slots defined in opposite side walls thereof, and a shaft extending through the slots. Opposite ends of the shaft are fixed in a front portion of the housing. When the optical fiber plug is to be inserted into the cavity of the housing, the shielding door is manually rotated outwardly and upwardly from a closed position to an open position, and then slid into the housing. Once the optical fiber plug is withdrawn from the optical fiber connector, the shielding door is manually slid outwardly, and then rotatably returned to its original closed position.

[0011] Other objects, advantages and novel features of the invention will become more apparent from the following detailed description when taken in conjunction with the accompanying drawings, in which:

### BRIEF DESCRIPTION OF THE DRAWINGS

[0012] FIG. 1 is a perspective view of a conventional plastic optical fiber connector, together with a complementary optical fiber plug connector;

[0013] FIG. 2 is a perspective view of a plastic optical fiber connector in accordance with the present invention, showing a shielding door thereof in a closed position;

[0014] FIG. 3 is a cross-sectional view taken along line III-III of FIG. 2;

[0015] FIG. 4 is a perspective view of the shielding door of the plastic optical fiber connector of FIG. 2;

[0016] FIG. 5 is similar to FIG. 4, but viewed from another aspect;

[0017] FIG. 6 is similar to FIG. 2, but also showing a complementary optical fiber plug connector;

[0018] FIG. 7 is similar to FIG. 6, but showing the shielding door in an open position; and

[0019] FIG. 8 is similar to FIG. 7, but showing the optical fiber plug connector inserted into a housing of the plastic optical fiber connector, and the shielding door fully inserted into the housing.

### DETAILED DESCRIPTION OF PREFERRED EMBODIMENT OF THE INVENTION

[0020] Referring to FIGS. 2, 3 and 6, a plastic optical fiber connector 3 in accordance with the present invention comprises a housing 32, an active device 33 and a shielding door 31. The housing 32 comprises a bottom wall 322, two

sidewalls **323** extending upwardly from opposite sides of the bottom wall **322**, a rear wall **324**, and a top wall **325**. A cavity **35** is defined in the housing **32**, for receiving a complementary optical fiber plug connector **4** therein. Two guide grooves **321** are defined in inner surfaces of the sidewalls **323** respectively, for slidably receiving the optical fiber plug **4**. The active device **33** is embedded in the rear wall **324** of the housing **32**. A plurality of conductive pins **331** of the active device **33** depends outwardly from the housing **32**, for electrically connecting with a printed circuit board (not shown). The active device **33** is generally a light-emitting diode or a laser diode for generating optical signals. The active device may alternatively be a photo diode for receiving optical signals and converting the optical signals into corresponding electrical signals. The shielding door **31** is disposed at a front of the housing **32**.

[0021] Referring to FIGS. 4 and 5, the shielding door **31** comprises a plate **311**, two side walls **315** perpendicularly extending in a same direction from the plate **311**, a handle **312** extending in an opposite direction from one end of the plate **311**, and a shaft **313** disposed at an opposite end of the plate **311**. The handle **312** facilitates manual operation of the shielding door **31**. Two slots **314** are respectively defined in the sidewalls **315**. The slots **314** are parallel and opposite to each other, and movably accommodate the shaft **313** therein. Opposite ends of shaft **313** are fixed in a front portion of the housing **32**. Thus the shielding door **31** is rotatable and slidable with respect to the shaft **313**.

[0022] Referring to FIGS. 6-8, the optical fiber plug **4** comprises a main body **45**, a ferrule **43** embedded in a front portion of the main body **45**, and an optical fiber cable **41** retained in a rear portion of the main body **45**. The two guide ribs **42** are formed on opposite sides of the main body **45** respectively, for engaging in the guide grooves **321** of the housing **32**.

[0023] Referring to FIG. 6, when optical fiber connector **3** is not in use, the shielding door **31** is oriented in a closed position. This prevents the active device **33** from being harmed by foreign contamination. Similarly, when the optical fiber plug **4** is withdrawn from the housing **32**, the shielding door **31** is manually closed.

[0024] Referring to FIG. 7, when the optical fiber plug **4** is to be inserted into the optical fiber connector **3**, the shielding door **31** is manually rotated outwardly and upwardly to an open position. In this position, the plate **311** of the shielding door **31** is substantially parallel to the top wall **325** of the housing **32**.

[0025] Referring to FIG. 8, the optical fiber plug **4** is then inserted into the cavity **35** of the housing **32**. The guide ribs **42** of the optical fiber plug **4** are engagingly received in the guide grooves **321** of the housing **32**. The shielding door **31** is then pushed into the housing **32**, with the sidewalls **315** of the shielding door **31** sliding over the shaft **313** of the shielding door **31**. When the shielding door **31** is fully inserted into the housing **32**, the handle **312** of the shielding door **31** abuts a front end of the housing **32**.

[0026] Once the optical fiber plug **4** is withdrawn from the optical connector **3**, the shielding door **31** is manually pulled outwardly, and then rotatably returned to its original closed position.

[0027] While the present invention has been described with reference to a particular embodiment, the description is

illustrative of the invention and is not to be construed as limiting the invention. Therefore, various modifications to the present invention can be made to the preferred embodiment by those skilled in the art without departing from the true spirit and scope of the invention as defined by the appended claims. For example, in an alternate embodiment the slot may be formed in the housing and the shaft may be formed on the door.

1. An optical fiber connector for receiving a complementary optical fiber plug connector, said optical fiber connector comprising:

a housing;

an active device embedded in the housing; and

a shielding door defining at least one slot, the door comprising a shaft extending through the at least one slot and being located in a front portion of the housing;

wherein the door is rotatable and slidable with respect to the shaft, and when the optical fiber plug connector is inserted into the housing, the door is slidably receivable in the housing.

2. The optical fiber connector as described in claim 1, wherein the door defines two slots disposed opposite to each other.

3. The optical fiber connector as described in claim 2, wherein the door further comprises two sidewalls, and the slots are respectively defined in the sidewalls.

4. The optical fiber connector as described in claim 1, wherein the door further comprises a handle for facilitating manual operation of the door.

5. The optical fiber connector as described in claim 1, wherein the active device is a laser diode.

6. The optical fiber connector as described in claim 1, wherein the active device is a light-emitting device.

7. The optical fiber connector as described in claim 1, wherein the active device is a photo diode.

8. An optical connector for receiving an optical fiber plug connector, said optical connector comprising:

a housing;

a shielding door defining at least one slot, the door comprising a shaft extending through the at least one slot and being located in a front portion of the housing;

wherein the door is rotatable and slidable with respect to the shaft, and when the optical fiber plug connector is inserted into the housing, the door is slidably receivable in the housing.

9. The optical fiber connector as described in claim 8, wherein the door further comprises a handle for facilitating manual operation of the door.

10. The optical fiber connector as described in claim 8, wherein an active device is embedded in the housing.

11. The optical fiber connector as described in claim 10, wherein the active device is a light-emitting device.

12. The optical fiber connector as described in claim 10, wherein the active device is a laser diode.

13. The optical fiber connector as described in claim 10, wherein the active device is a photo diode.

14. A connector assembly comprising:

a housing defining a cavity therein;

a plug mateable with said housing; and

a shielding door moveable relative to the housing with interengaging device; wherein

when no plug is inserted into the cavity, said shielding door is, in a vertical position, vertically located around a front opening of said cavity to shield said cavity; when the plug is inserted into the cavity, said shielding door is, in a horizontal position, substantially horizontally received in an portion of the cavity and thus is located between said plug and one side wall of said housing in a vertical direction of the housing.

**15.** The assembly as described in claim 14, wherein said shielding door further includes a handle around an end thereof.

**16.** The assembly as described in claim 15, wherein said handle is closely adjacently located around one side of said front opening when said shielding door is in the vertical position, and is closely adjacently located around another side of said front opening opposite to said side when said shielding door is in the horizontal position

\* \* \* \* \*