

July 13, 1937.

E. L. TAYLOR

2,086,751

EARTH BORING BIT

Filed Dec. 19, 1934

3 Sheets-Sheet 1

Fig. 1.

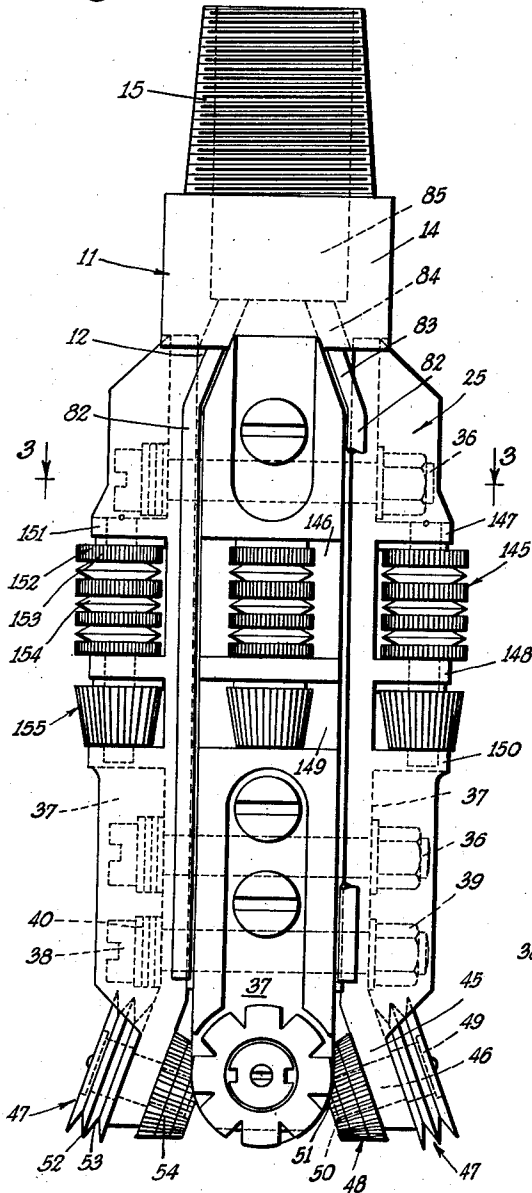

Fig. 3.

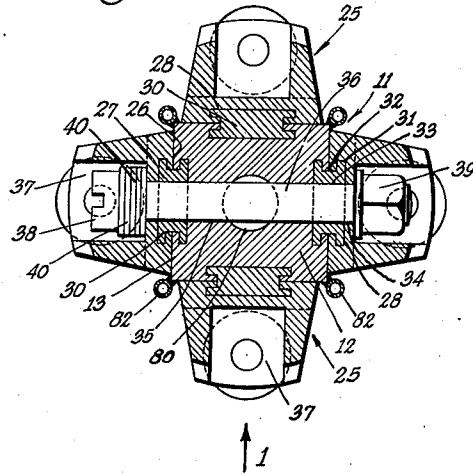
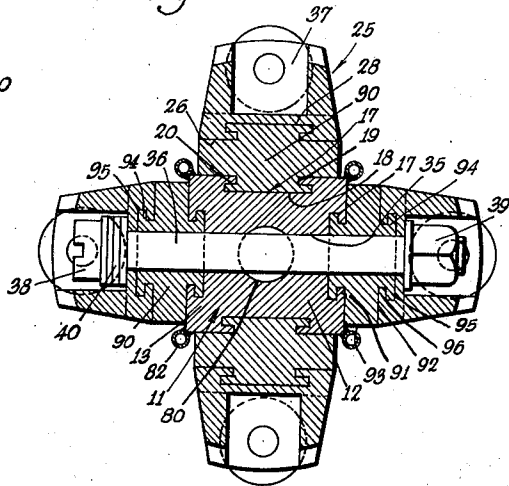

Fig. 4.



Inventor
E. L. Taylor
by Hazard and Miller
Attorneys.

July 13, 1937.

E. L. TAYLOR

2,086,751

EARTH BORING BIT

Filed Dec. 19, 1934

3 Sheets-Sheet 2

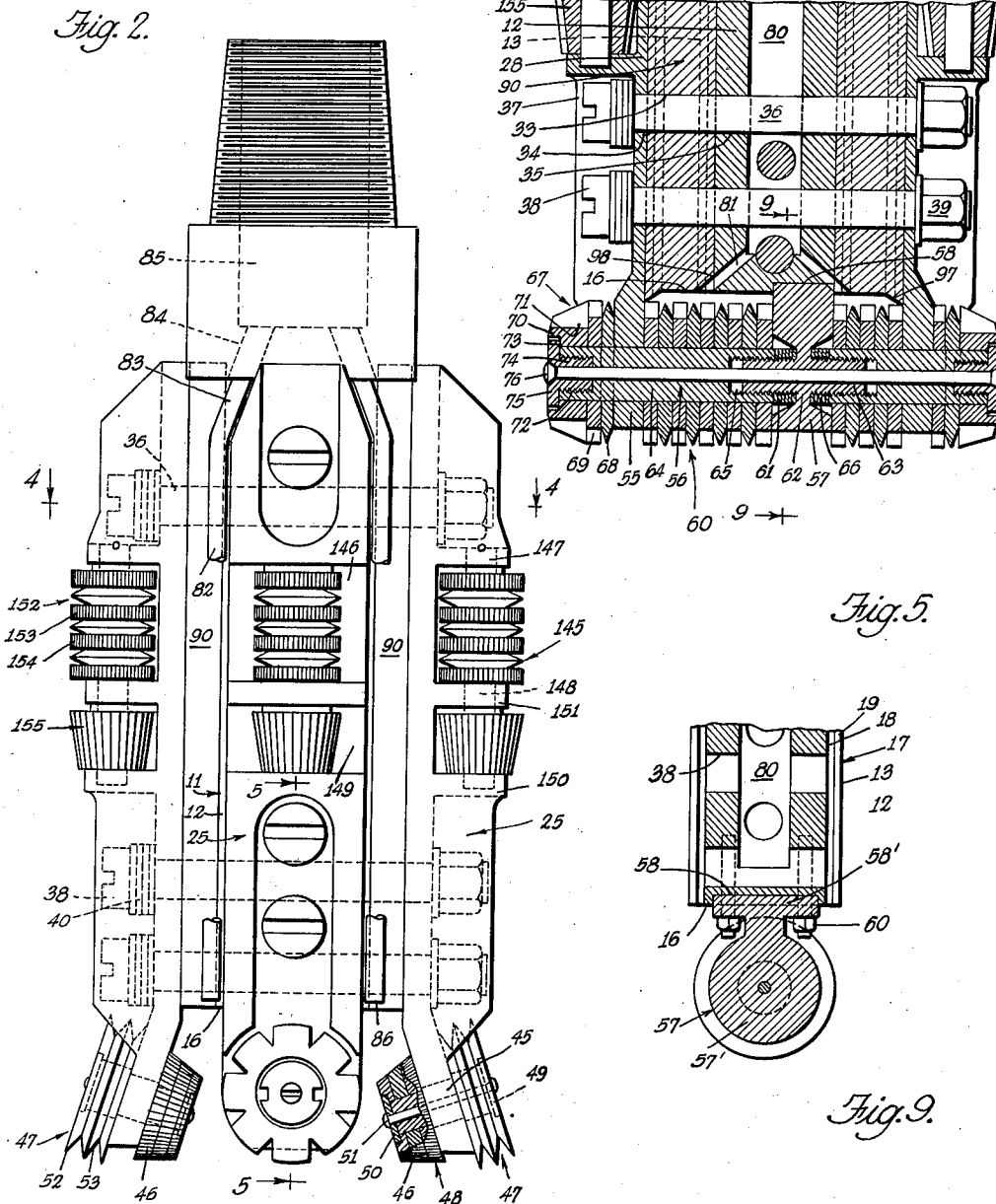

Inventor
E. L. Taylor
by Hazard and Miller
Attorneys.

July 13, 1937.

E. L. TAYLOR

2,086,751

EARTH BORING BIT

Filed Dec. 19, 1934

3 Sheets-Sheet 3

Fig. 6.

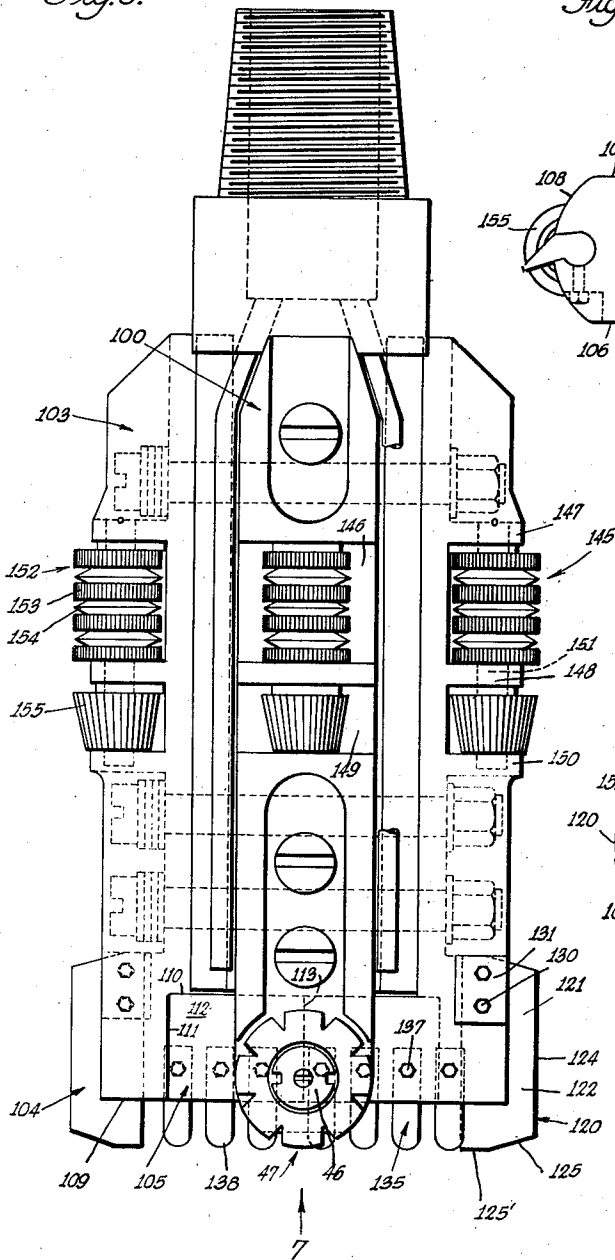

Fig. 7.

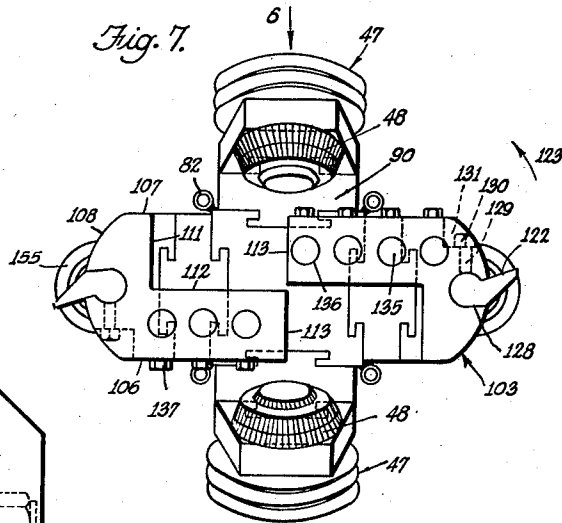
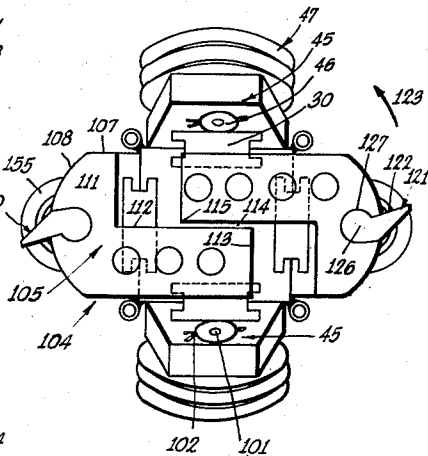

Fig. 8.



Inventor
E. L. Taylor
by
Hazard and Miller
Attorneys.

UNITED STATES PATENT OFFICE

2,086,751

EARTH BORING BIT

Edward L. Taylor, Long Beach, Calif.

Application December 19, 1934, Serial No. 758,252

14 Claims. (Cl. 255-71)

My invention relates to a combination type of reamer rock and drag rotary drill bit in which, when used as a rock drill, the cutters are of a rotating cutter type in which a row of rotary cutters mounted on a transverse shaft extend across one diameter of the bit and at the marginal ends of the other diameter there are opposed pairs of sets of rotary cutters these being slightly inclined with their axes tilted downwardly and inwardly. When the drill is used as a drag bit the set of transverse rotary cutters are removed and a drag bit construction substituted. For cutting completely across the formation from side to side at the bottom of the hole these cutters are provided with a plurality of cutting teeth.

In the above type of drill bit an object and feature of my invention is a construction by which the same shank may be used for a mounting of the rock bits having the rotary cutters or alternatively, for the drag bit having the drag cutters and cutting teeth. By the shank I mean the heavy central part of the drilling bit, this having a head and preferably a pin at the upper end which pin may be threaded in the box of a tool joint coupling or other connection, to the rotary drill pipe.

A further feature of my invention is constructing the shank substantially square in cross section as to its upper periphery and this being of the same cross section from the top to the bottom. On each face of the shank, removable tool carrying blocks are attached by bolts, or the like, such bolts extending through the shank from side to side. One pair of diametrically opposite blocks forms at its lower end the end bearings for the transverse shaft carrying the rotary disc cutters. There is also a central bearing block which is attached to the lower end of the shank, such shank having preferably a substantially plane lower end. The central bearing block is bolted to the end of the shank.

A detailed feature of my invention thus relates to the assembly of the tool supporting blocks attached to the four vertical faces of the shank, two opposite tool blocks at their ends forming a mounting for a transverse row of rotary cutting disks mounted on a diametrical shaft. The other two tool blocks only have rotary cutters on their lower ends, each having a stub shaft mounted at its center in a web on the tool block extending below the bottom of the shank, such stub shaft having rotating cutter disks thereon located outside and inside of the web.

Another object and feature of my invention in

the substitution of the drag bit is in employing a construction having two tool blocks which may be substituted for the tool blocks having the cutting discs mounted thereon. These substitute blocks are bolted on two opposite faces of the shank by bolts extending through the blocks and through the shank, and at the bottom of each substitute tool block there is formed integral therewith a transverse drag bit cutter, the two cutters extending transversely across the tool in a diametrical manner. A detailed feature of the drag bits is that diametrically opposite on the extreme outside edge at the bottom I provide removable end cutters which cut the extreme outside of the hole bottom and have a vertical cutting edge for the side wall. These removable marginal cutters are each fitted in a socket in one of the drag bit sections or cutters.

A further detailed feature is in the employment of cutting teeth insertable in sockets formed in the lower face of each drag cutter. Therefore, broadly it may be stated that one of the main objects of my invention is in the construction of the rotary drill bit in which side blocks may be attached to or removed from the shank and these form the supports for rotating disk cutters or have fixed drag cutters. Another object and feature of my invention is in the provision for expansion and contraction of the drill bit to cut down sizes of holes.

Therefore, another main object and feature of my invention is in employing attaching keys in the form of shims interconnecting the lateral tool blocks to the central shank, these keys or shims being in different sizes or thicknesses so that by the use of substitute keys the diameter of the drill as a whole may be increased from its minimum size. In this construction of the shims I provide vertical undercut grooves in each face of the square sectioned drill shank and in each of the tool blocks I likewise provide a complementary undercut groove. The keys are made in corresponding manner with projecting tongues, the shims with the tongues may be assembled on the shaft and the tool blocks on the shims by a longitudinal sliding movement and then the assemblies tilted through the shank.

To accommodate the expansion for the rock drill having the rotary cutters a plurality of shims may be inserted on the main cutter disk shaft, this shaft being preferably formed in a plurality of sections, each having its end connected to a stub shaft on the central bearing. The expanding feature, in regard to the drag bit, also accommodates an overlap of the drag bit

cutters when in the contracted position and outward movement of these when the larger key shims are used.

A further feature of my invention relates to employing the tool blocks on the square sectioned shank as mountings for rotary reamers, these being on a vertical shaft on each tool block section.

Another detailed feature relates to the construction of ducts for the slushing mud, a central duct passing longitudinally through the center of the shank and also preferably four ducts constructed of pipes leading downwardly on each corner of the shank adjacent the corners formed by the tool blocks.

My invention is illustrated in connection with the accompanying drawings, in which:

Fig. 1 is a side elevation taken in the direction of the arrow 1 of Fig. 3 illustrating the bit arranged as a rock drill with rotary cutters and in its contracted or smallest cutting diameter.

Fig. 2 is a similar elevation to Fig. 1 but with the bit expanded to a larger diameter by using insert key shims to space the tool supporting blocks from the shank.

Fig. 3 is a horizontal section on the line 3—3 of Fig. 1 in the direction of the arrows illustrating the use of keys between the shank and the tool blocks.

Fig. 4 is a horizontal section on the line 4—4 of Fig. 2 taken in the direction of the arrows illustrating key shims spacing the tool blocks from the shank.

Fig. 5 is a vertical transverse section on the line 5—5 of Fig. 2 in the direction of the arrows showing in particular the transverse rotary cutters.

Fig. 6 is a side elevation taken in the direction of the arrow 6 of Fig. 7 showing the bit expanded and with a drag cutter substituted for the transverse rotary cutters.

Fig. 7 is an end view of Fig. 6 taken in the direction of the arrow 7.

Fig. 8 is a view similar to Fig. 7 with the key shims removed and showing the tool reduced to its smallest cutting diameter.

Fig. 9 is a detail vertical section on the line 9—9 of Fig. 5 in the direction of the arrows.

Dealing first with the construction of Figs. 1 through 5, the main body or shank bit designated by the numeral 11 has an elongated shank section 12 which is square in cross section having equal flat side faces 13, which, when the tool is operating are each in a vertical plane. At the upper end of this main shank there is a cylindrical head 14 and a taper threaded pin 15, the pin being adapted to thread into a box of a tool joint coupling or the equivalent. The lower end of the shank preferably has a plane horizontal surface 16 (note Figs. 2 and 5). Each vertical face of the shank is provided with an undercut groove 17, such groove having a vertical surface 18 with parallel marginal guide shoulders 19 thus forming the undercut portion 20 of the grooves. These are all of similar construction on the four faces of the square portion of the shank.

The tool holding blocks 25 are all of the same general type having vertical plane inner faces 26 to register with the vertical faces of the square section of the shank and each of these has an undercut groove 27 having a vertical base surface 28. The vertical grooves in the shank and in the tool blocks are preferably similar so that keys 30 may be utilized and fit in the grooves,

the keys being inserted longitudinally from the bottom. (Note Fig. 3.) Each key has two marginal tongues 31 on each vertical edge supported by a groove 32. The keys are provided with perforations 33 at spaced intervals. The tool blocks also have perforations 34 at similar spacing and the square section of the shank is also provided with transverse perforations 35. Through these perforations extend bolts 36, there being recesses 37 in the side faces of the tool blocks to accommodate the head 38 and the nut 39 of the bolts. Filling washers 40 are preferably used when the bit is in its contracted or smallest drilling diameter so that one set of bolts will accommodate a number of different size conditions of drilling. The bolts preferably extend diametrically through the center of the square shank section and thus are located in the vertical center of the tool blocks. Two of the tool blocks at the bottom are provided with outwardly flared webs 45 (note Figs. 1 and 2), such webs extending below the bottom 16 of the square shank section. Mounted in the center of each of these webs there is a stub shaft 46, which shaft carries cutter discs 47 on its outer end and a series of toothed cutter discs 48 on the inner end of the stub shaft. Such stub shaft is provided with an enlarged head 49 at one end and a washer 50 at the opposite end is held in place by a rivet 51 through shaft 46, the rivet heads engaging the shaft head 49 and washer 50, thus attaching the rotary cutters to the stub shaft 46 and retaining the cutters on such shaft. It will therefore be seen, referring to Figs. 1 and 2, that the stub shafts 46 are downwardly and inwardly inclined toward the axial center of the bit. The cutters 47 preferably have annular cutting edges 52 separated by grooves 53 and the cutters 48 preferably have a series of teeth 54, such teeth extending longitudinally of the stub shaft 46. It will be noted, referring to the illustrations of Figs. 1 and 2, that one bolt is used at the upper portion of each of the tool blocks and two bolts adjacent the lower end of each pair. Therefore, a short recess is sufficient at the top and a long recess at the bottom to accommodate the bolt heads and nuts.

The other pair of tool blocks are fastened to the two remaining diametrically opposed faces of the square section of the shank, the manner of attachment being the same as above described. These blocks, however, have a downwardly extending web 55 which is parallel to the plane of the vertical face of the square shank section. (Note Fig. 5.) These form outer supports for a diametrical cutter shaft 56. There is also provided a central bearing block 57, the lower portion 57' being a cylinder joined to a block 58' which is seated in a shallow recess 58 in the lower surface 16 of the square shank section preferably offset slightly from the center. This central block is secured in place by bolts 60 through the box. The opposite sides of the center block 57 have recesses 61 leaving a central fin 62, from which fin extend in opposite directions, two threaded shaft end supports 63. The shaft as a whole has two portions 64 with a threaded recess 65. The recesses 61 are to accommodate a series of filling washers 66 when the tool is expanded.

On the shaft 56 outside of the webs 55 there is a series of rotary cutters 67, these shown being a disc 68 with a sharp peripheral edge, and discs 69 with teeth parallel to the shaft and an outer disc 70 with large teeth 71. Each of the cutters

70 has a screw threaded socket 72 and a shallow recess 73 in which there is a threaded plug 74 engaging the threads of the recess 72 and having a head 75 fitting in the shallow recess 73. A locking rivet 76 extends through perforations in the plug 74 and shaft side 64, 63 and fin 62. The cutters of such shaft section between the webs 55 are preferably formed alternately of disc cutters similar to 68 having the sharp peripheral edge and cutters similar to 69 having teeth, but it is manifest that any suitable type of intermediate cutters may be used. The shaft 56 formed of the screw threaded fixed portion 63 and the outer fixed portion 64 do not rotate but the cutters turn on such shaft.

In order to provide for the circulation of the slushing mud there is a central axial duct 80 extending from the pin 15 through a head 14 and a square section of a shank. This is of sufficient diameter so that the bolts 36 securing the tool blocks do not obstruct the duct, or if desired, the duct may be enlarged at the position occupied by the bolts. At the bottom there are diverging ducts 81 (note Fig. 5) which carry the slushing fluid laterally and discharge some of the flow on the transverse row of rotary cutters. There are also four pipes 82 which are located adjacent each of the corners of the square section of the shank and occupy the four corners formed by the four tool blocks. These pipes are inwardly bent at the top 83 (note Figs. 1 and 6), and connect to ducts 84 leading from the large opening 85 in the head and pin. These pipes have their discharge outlet 86 spaced slightly above the lower end 16 of the shank.

When it is desired to enlarge the drill bit for drilling an increased diameter hole, the bolts attaching the tool blocks are removed, then the keys 30 are also removed by a longitudinal movement, it being first necessary to disconnect the shaft sections 64 from the fixed shaft 63 (note Fig. 5) and thus disassemble the transverse rotary cutters. This allows a complete disassembling of the tool blocks from the square portion of the shank. Then, the shim keys 90 may be substituted for the keys 30. Such keys are illustrated in cross section in Fig. 4 and have a central shim portion 91, this having parallel opposite faces 92 and parallel side edges 93 except on the faces 92 key elements are formed. These have marginal tongues 95 with undercut grooves 96 and are designed to fit in the undercut grooves formed in the vertical side faces of the square section of the shank and also forming the inside vertical faces of the tool blocks 25. These shim keys 90 have perforations to accommodate the clamping bolts and when assembled, the bolts pass through the tool blocks, the shim keys 90 and the central squared section of the shank thus securely attaching the tool blocks to the side faces of the shank.

In Fig. 6 this vertical section shows the lower portion of a pair of shim keys 90 which may have a slight downwardly extending corner 97 engaging the webs 55. These blocks also have cut-off corners 98 to form a continuation of the slushing duct 81. It is also necessary to have cut-off corners in the keys 30 to accommodate the flow of the slushing mud through the ducts 81.

It is manifest that different sizes of key shims 90 may be used when it is desired to enlarge the drilling diameter from the contracted size as shown in cross section in Fig. 3 having the narrow keys 30. On account of the shaft sections 64 being threaded on the fixed shaft section 63 of

the central block 57, accommodation may be made for enlarging the diameter of the tool and a suitable number of cutters may be used on this shaft to accommodate the shaft either when shortened or elongated, and, manifestly, the desired number of filling washers 66 may be utilized.

It will thus be seen that the bit is readily adapted for alteration to drill diameters of a hole using the rotary type of rock cutters.

When it is desired to utilize the drag bit construction of Figs. 6, 7, and 8 I proceed as follows:

In this case the diametrically opposite tool holders 100 having the flared web 45 are the same as used in the prior described construction employing the rock bit, and in fact, the same tool blocks may be used in both cases on these two faces of the squared shank. When the tool is contracted as shown in Fig. 8 I utilize the same type of keys 30 and these may be of the same size, and when the tool is expanded as illustrated in Fig. 7 I utilize the substitute key shims 90. When the device is expanded to a sufficient diameter I may use the cutter assembly on the stub shafts 46 having the various cutters 47 and 48 but where the tool is contracted as in Fig. 8 or only narrow shim keys are employed it is necessary to omit the inside cutters 48, in which case, for the stub shafts 46 I substitute a shorter stub shaft 101. This may have a head such as 49 and is secured in place by a cotter pin 102, or the like. Thus the stub shaft 101 may be held in any suitable manner in its supporting web 45 and carries the outside cutters 47 which may be of any suitable type. The two other tool blocks 103 are substituted for the tool blocks of Figs. 1 through 4 having the web 55 at the bottom which carries the transverse rotary rock cutters. However, the upper portion of these blocks may be of the same type as the blocks formerly used so that when the device is in its contracted structure the simple keys 30 may be used on the sides and the enlarged key shims 90 to expand the tool. In this case however, the drag bit assembly 104 employs separate drag bit elements 105 each of which is formed integral with the tool block 103 at the lower end (note details in Figs. 6, 7, and 8). In this case each tool block has parallel sides 106 and 107 rounded at their outside lower ends 108 connecting these sides. The bottom 109 of each drag bit element extends below the lower surface 110 of the main portion of the tool block 103. An inside vertical base 111 extends inwardly from the side 107 and terminating this there is a face 112 parallel to the faces 106 and 107 and the faces 106 and 112 are connected by a vertical end face 113. There is a slight space 114 between the faces 112. Thus, as the overlap drag bit elements are formed integral with the tool blocks 103 it is necessary to first attach the keys 30 or the shim keys 90 to the square section of the shank and slide the key blocks 103 upwardly from the lower end of the tool and then bolt these in place by the bolts in the same manner as described in Figs. 1 through 5. It will be noted when the tool is contracted as shown in Fig. 8 that there is a considerable overlap between the corners 115 formed by the junction of the vertical faces 112 and 113 but that there is a considerable space between the vertical inset face 111 and the vertical end face 113 of the two drag bit elements. The junction of the faces 106 of these elements on the lower surface 109 forms the cutting edge of the drag bit elements.

The drag bit elements are provided with additional cutters and have end and marginal cutters 120, these being shown in elevation in Fig. 6 and in end view in Figs. 7 and 8. Each of these has a laterally extending cutting blade 121 with a plane vertical front surface 122, the direction of rotation being that of the arrow 123. (Note Figs. 7 and 8.) These have a vertical edge 124, an inwardly sloping bottom edge 125, and a horizontal inward extension 125' thereof. Each of these blades has a bulbous inner end portion 126 which forms part of a cylinder and this fits in a cylindrical vertical recess 127 extending upwardly in the lower end of each tool block 103 in the portion forming the outside of the drag bit element 105. A lateral slot 128 extends from the curved surface 108 and communicates with the cylindrical recess 127. Thus these marginal cutter blades may be inserted upwardly from the lower end of the drag bit elements and are held tightly in place by locking bolts 129 which have their heads 130 resting on the bottom of the cut-out corner recesses 131 in each drag bit element 105, such recesses being spaced above the bottom 109.

In addition, cylindrical cutting teeth 135 are utilized in the drag bit elements each of which extends upwardly in a cylindrical recess 136 of each drag bit element, and is held in place by a set screw 137. The lower ends of these cylindrical teeth are shown as domed as indicated at 138 forming substantial hemispheres at such ends. It is to be noted that these cutting teeth or pins 135 are located out of symmetry on the drag bit elements 105 there being three shown on one element and four on the other, and they are so spaced that the core left in the center of the tool is so small that it would break off and moreover, when the tool is expanded to its greatest diameter shown in Fig. 7, the corners 115 of each drag bit element 105 are practically contiguous at the center of the expanded tool.

From the above description it will be seen that with my construction of drill bit using the shank of square cross section the grooves and locking keys and locking key shims together with the removable tool holder blocks, I may readily change the rock drill having rotary cutters from a smaller to a larger diameter for cutting different sized holes. Also, by substituting two tool holder blocks with drag bit elements I may change the type of bit to one in which the drag bit is used as the main cutting tool and this may also be changed from a small diameter tool to a larger diameter tool in accordance with the size of hole to be drilled.

In connection with both of these types of tools I use a set of reamers designated by the assembly numeral 145 (note Figs. 1, 2, and 6). In this case, on each of the tool supporting blocks there is a lateral recess 146 in an upper portion, above which is a transverse shelf 147. Below this recess there is a transverse tongue 148, a second lower recess 149, and a transverse shelf 150 therebelow. The reamer shaft 151 extends through the tongue 148 and is supported in each of the transverse shelves 147 and 150. In the upper recess 146 there are a series of reaming disk cutters 152 in which certain of these 153 have longitudinal teeth, and other discs 154 have a sharp peripheral cutting edge. In the recess 149 and on the shaft 151 there are tapered reaming tools 155, these having longitudinally extending teeth. Thus, it will be seen that no matter whether the bit is operating in a small or a large hole with the rock type of rotary cutters or the drag bit type of

cutter, I obtain a reaming action, and on account of the reaming tools being mounted on each of the tool holding blocks these are assembled and disassembled from the shank when making changes in the type of cutters used for forming the hole.

The length of the cutter shaft 56 (note Fig. 5) may be adjusted to a slight extent due to the threaded connection between the threaded shaft support 63 and the outer portions 64. This accommodates different sized cutters 60 between the webs 55. When a change is made, however, by either inserting key shims or removing these to contract the tool, the substitute end portion 64 must be used.

The screw threaded adjustment of the several sections of the shaft 56 will accommodate changes in diameter if the shims do not differ greatly in size, and also accommodates these in different size cutters 67 on the outside of the webs 55.

Various changes may be made in the details of construction without departing from the spirit or scope of the invention as defined by the appended claims.

I claim:

1. A bit having a shank with a plurality of sides, tool holding blocks, means to attach each to one of the sides of the shank, each block having cutters to operate on the bottom of the hole, the attaching means having in part elements to space the said blocks from the sides of the shank, a diametrically opposite pair of tool blocks having a cutter supporting means interconnecting the lower portion of said latter blocks with cutters thereon, means attaching said latter blocks to the shank the said latter cutters being located below the bottom of the shank.

2. A bit having a shank, with outside faces, a plurality of tool holding blocks each having inside faces, a key between each shank face and block face, the shank and the block faces and the keys having an interlocking means, bolts for removably attaching the blocks and keys to the shank, the keys being of a type adapted to be interchangeable.

3. A bit as claimed in claim 2, the cutters on the tool blocks being of a rotary type and a shaft extending between two of the blocks and having rotary cutters thereon below the bottom of the shank, the said shaft having means to accommodate a different spacing of the tool holding blocks.

4. A bit as claimed in claim 2, a bearing block secured to the bottom of the shank intermediate two opposite sides, a shaft mounted in the lower end of two of the diametrically opposite tool holding blocks, an extensible and contractible shaft having a mounting respectively in the said lower ends of the two blocks and the central bearing block and rotary cutters on the said shaft.

5. A bit as claimed in claim 2, each of the tool holding blocks having substantially vertical shafts and each shaft having a plurality of rotary reaming tools thereon.

6. A bit as claimed in claim 2, two of the diametrically opposed tool holding blocks having each a drag bit element secured thereto at its lower end, each drag bit element having a portion thereof extending below the bottom of the shank.

7. A bit as claimed in claim 2, two of the diametrically opposed tool holding blocks having each a drag bit element secured thereto at its lower end, each drag bit element having a portion

thereof extending below the bottom of the shank, each drag bit element having a plurality of cutters thereon, said cutters being detachable from the drag bit elements and extending downwardly below the lower edge of the drag bit elements.

8. A bit having a shank substantially rectangular in cross section and having four equal size vertical faces, each vertical face having a vertical undercut groove, four tool holding blocks each having an inner vertical face with an undercut groove therein, the faces of the shank and blocks being adapted to receive a plurality of keys each having two pairs of marginal tongues on vertical edges, the two pairs of tongues being spaced apart by the thickness of the key, the said key being insertable in the under cut grooves of the shank and the tool holding blocks, bolts attaching the tool holding blocks, the keys and the shank in an assembly, each tool holding block having cutting tools to operate on the bottom of the hole cut by the bit.

9. A bit as claimed in claim 8, two of the diametrically opposite blocks having each a downwardly extending web, said webs diverging outwardly, each of said webs having a stub shaft mounted therein and each stub shaft having rotary cutters, the other pair of diametrically opposite blocks each having a tool connected thereto and extending downwardly below the bottom of the shank, the said tool extending across the bottom of the shank.

10. A bit comprising in combination, a shank substantially square in cross section and having four vertical faces, a first pair of tool holding blocks attached on diametrically opposite faces of the shank, each block having a web at its lower end with rotary cutters mounted thereon, tool holding blocks on the remaining two opposite

sides of the shank, said latter blocks having cutting tools mounted on their lower ends and extending across the shank below the bottom thereof, said shank having a central conduit for slushing fluid and a plurality of conduits located at about substantially the corners of the shank and between adjacent tool holding blocks.

11. A bit, comprising in combination a shank substantially square in cross section and having four vertical faces, a first pair of tool holding blocks attached on diametrically opposite faces of the shank, each block having a web at its lower end with rotary cutters mounted thereon, tool holding blocks on the remaining two opposite sides of the shank, said latter blocks having drag bit elements secured thereto, said shank having a central conduit for slushing fluid and a plurality of conduits located at substantially the corners of the shank between adjacent tool holding blocks.

12. A bit having a shank with four vertical faces, two pairs of diametrically opposite tool holding blocks, bolts securing each pair of blocks to the shank, one of the pairs of tool holding blocks having cutters extending diametrically across the bit below the shank, the other pair of blocks having rotary cutters.

13. A bit as claimed in claim 12, the said cutters being mounted on a shaft, said shaft being secured to the lower ends of the first mentioned pair of blocks, the said cutters being rotary.

14. A bit as claimed in claim 12, the said pair of blocks having the cutters below the shank having such cutters rigidly secured to the lower ends of the said blocks, certain of the said fixed cutters being adapted to overlap.

E. L. TAYLOR,