



- (51) International Patent Classification:
G02B 6/02 (2006.01)
- (21) International Application Number:
PCT/US2013/043262
- (22) International Filing Date:
30 May 2013 (30.05.2013)
- (25) Filing Language: English
- (26) Publication Language: English
- (30) Priority Data:
13/485,192 31 May 2012 (31.05.2012) US
- (71) Applicant: CORNING CABLE SYSTEMS LLC [US/US]; 800 17th Street NW, Hickory, North Carolina 28601 (US).
- (72) Inventors; and
- (71) Applicants : BUTLER, Douglas Llewellyn [US/US]; 25 Katie Lane, Painted Post, New York 14870 (US). ISEN-HOUR, Micah Colen [US/US]; 1008 Park Circle, Lincolnton, North Carolina 28092 (US). KNECHT, Dennis Michael [US/US]; 4921 Elmhurst Drive, Hickory, North Carolina 28601 (US). LUTHER, James Phillip [US/US]; 2471 Rolling Ridge Drive, Hickory, North Carolina 28602 (US).
- (74) Agent: CARROLL, JR., Michael E.; Corning Cable Systems LLC, Intellectual Property Department, SP-TI-03-1, Corning, New York 14831 (US).

(81) Designated States (unless otherwise indicated, for every kind of national protection available): AE, AG, AL, AM, AO, AT, AU, AZ, BA, BB, BG, BH, BN, BR, BW, BY, BZ, CA, CH, CL, CN, CO, CR, CU, CZ, DE, DK, DM, DO, DZ, EC, EE, EG, ES, FI, GB, GD, GE, GH, GM, GT, HN, HR, HU, ID, IL, IN, IS, JP, KE, KG, KN, KP, KR, KZ, LA, LC, LK, LR, LS, LT, LU, LY, MA, MD, ME, MG, MK, MN, MW, MX, MY, MZ, NA, NG, NI, NO, NZ, OM, PA, PE, PG, PH, PL, PT, QA, RO, RS, RU, RW, SC, SD, SE, SG, SK, SL, SM, ST, SV, SY, TH, TJ, TM, TN, TR, TT, TZ, UA, UG, US, UZ, VC, VN, ZA, ZM, ZW.

(84) Designated States (unless otherwise indicated, for every kind of regional protection available): ARIPO (BW, GH, GM, KE, LR, LS, MW, MZ, NA, RW, SD, SL, SZ, TZ, UG, ZM, ZW), Eurasian (AM, AZ, BY, KG, KZ, RU, TJ, TM), European (AL, AT, BE, BG, CH, CY, CZ, DE, DK, EE, ES, FI, FR, GB, GR, HR, HU, IE, IS, IT, LT, LU, LV, MC, MK, MT, NL, NO, PL, PT, RO, RS, SE, SI, SK, SM, TR), OAPI (BF, BJ, CF, CG, CI, CM, GA, GN, GQ, GW, KM, ML, MR, NE, SN, TD, TG).

Published:

— without international search report and to be republished upon receipt of that report (Rule 48.2(g))

(54) Title: ANGULAR ALIGNMENT OF OPTICAL FIBERS FOR FIBER OPTIC RIBBON CABLES, AND RELATED METHODS

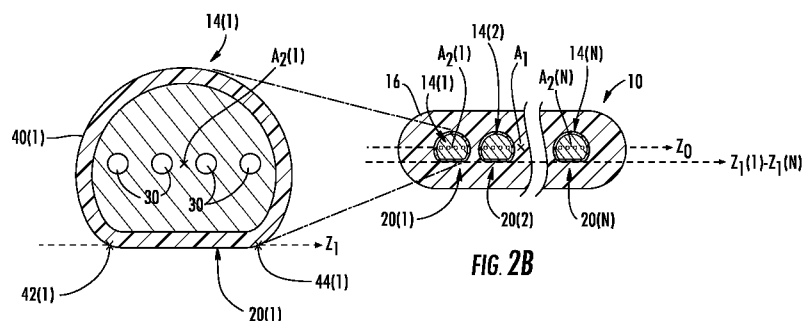

FIG. 2B

(57) Abstract: Angular alignment of optical fibers for fiber optic ribbon cables and related methods are disclosed. Employing optical fibers disposed in a ribbon matrix can increase bandwidth between two interconnection points. In one embodiment, optical fibers are angularly aligned during the process of forming a fiber optic ribbon cable. To angularly align the optical fibers, each of the optical fibers include an angular alignment feature to facilitate uniform or substantially uniform angular orientation along a cable when the optical fibers are prepared to be disposed in the ribbon matrix to form a fiber optic ribbon cable. By purposefully aligning the optical fibers during formation of the fiber optic ribbon cable, end portions of the optical fibers are aligned in the ribbon matrix. End portions of the matrix are not required to be removed to expose and align the end portions of optical fibers when the cable is connected.



ANGULAR ALIGNMENT OF OPTICAL FIBERS FOR FIBER OPTIC RIBBON CABLES, AND RELATED METHODS

PRIORITY

[0001] This application claims the benefit of priority under 35 U.S.C. §120 of U.S. Application Serial No. 13/485,192 filed on May 31, 2012 the content of which is relied upon and incorporated herein by reference in its entirety.

Field

[0002] The technology of the disclosure relates to fiber optic ribbon cables comprising multiple optical fibers disposed in a ribbon matrix to support multiple optical pathways.

Background

[0003] Benefits of optical fibers include extremely wide bandwidth and low noise operation. In cases where high bandwidth is required between two interconnection locations, fiber optic cables may be used to provide sufficient bandwidth to communicate information between these locations.

[0004] In cases where greater optical interconnect density is required with multiple connection points in a small area, fiber optic ribbon cables may be used. Fiber optic ribbon cables provide multiple optical fibers disposed in parallel in a cable. As demand for higher bandwidth increases, interconnection technologies must accommodate more optical fibers or adapt other techniques to provide more bandwidth, for example, multicore optical fibers. At each of the interconnection locations, the end of each optical fiber must be precisely aligned with optical components to exchange optical information or unacceptable signal attenuation may occur. Optical fibers are typically optically coupled at the interconnection location using fiber optic connectors which enable efficient connection and disconnection of the optical fibers at interconnection locations.

[0005] Conventional connectors utilized with commercially-available single-core optical fibers use passive alignment or active alignment to ensure that the single-core optical fibers are properly located within the connector. Passive alignment allows an end of the single-core optical fiber to be inserted into a precisely-shaped circular opening of a ceramic ferrule to align the single core, which includes a single optical path, to a center of

the circular opening. The passive alignment used for single-core optical fibers is not sufficient to align multicore optical fibers, because angular orientation is also required for alignment. Specifically, when a multicore optical fiber is inserted into an opening of a ferrule, not every core (including an optical path) of the multicore optical fiber will be located at a center of the opening of the ferrule. Precise angular orientation of each of the multicore optical fibers within the ferrule is required for alignment to a fiber optic connector. Conventional fiber optic connectors for single-mode optical fibers using passive alignment techniques do not align optical fibers in accordance with angular orientation and thereby are unsuitable for multicore optical fibers.

[0006] Alternatively, active alignment is the customized placement of an end of an optical fiber at an interconnect point in terms of X, Y, and Z coordinates and also angular alignment, depending on optical fiber type, to meet the optical transmission requirements of the optical fiber at that interconnection point. Active alignment typically requires time-consuming optical diagnostic equipment to ensure that each optical fiber is properly orientated within the connector before being fixed into place. In this regard, multicore optical fibers are even more difficult and time consuming to actively align compared to single-mode optical fibers given the additional requirement of angular alignment.

[0007] Regardless of whether passive or active alignment techniques are used, connecting multiple multicore optical fibers combined in a ribbon cable provides additional problems because the inefficiencies of each of the alignment techniques are accumulated. A ribbon cable includes multiple optical fibers orientated in parallel and connected by a ribbon matrix (or outer cable jacket) holding the optical fibers together. Each optical fiber must be aligned to the connector. Specifically, to actively align a multicore optical fiber in a ribbon cable, a ribbon matrix (the outer cable jacket) may have to be substantially removed or “cut back” in order to free optical fibers needing large angular adjustments to complete alignment at an interconnection point. Cutting back the ribbon matrix may be infeasible because substantial cutting of fiber optic ribbon cables is overly time consuming. Moreover substantially removing the ribbon matrix (“cutting back”) exposes portions of the optical fibers to damage. In this regard, improved approaches are needed to provide a high density of easily connectorized optical paths in a cost effective manner.

SUMMARY

[0008] Embodiments disclosed herein include angular alignment of optical fibers for fiber optic ribbon cables and related methods. Multiple optical fibers disposed in parallel in a ribbon matrix may be used to increase bandwidth between two interconnection points. In this regard, optical fibers are angularly aligned during the process of forming a fiber optic ribbon cable. To angularly align the optical fibers, each of the optical fibers may include an angular alignment feature. The angular alignment feature facilitates uniform or substantially uniform angular orientation along a cable center axis of each of the optical fibers when the optical fibers are prepared to be disposed in the ribbon matrix to form a fiber optic ribbon cable. The uniform or substantially uniform angular orientation may facilitate alignment of each of the optical fibers as part of a process to optically connect each of these optical fibers precisely to a fiber optic connector. The optical fibers are held in angular alignment when provided in the ribbon matrix.

[0009] By purposefully aligning the optical fibers along their length during the formation of the fiber optic ribbon cable, the end portions of the optical fibers are aligned in the ribbon matrix. Thus, end portions of the ribbon matrix are not required to be removed (e.g., stripped or cut back) to expose and align the end portions of optical fibers when the ribbon cable is connectorized. Removing the end portions of the ribbon matrix incurs additional manufacturing labor and time, and associated expense. Also, having to expose lengths of the end portions of the optical fibers from the ribbon matrix for alignment can provide a greater risk damaging the optical fibers during connectorization.

[0010] In this regard in one embodiment, a fiber optic ribbon cable is provided. The fiber optic ribbon cable may include a plurality of optical fibers comprising a first end and a second end. The fiber optic ribbon cable may also include a ribbon matrix attached to each of the plurality of optical fibers. The ribbon matrix may extend from the first end to the second end. Each of the plurality of optical fibers may include an angular alignment feature extending from the first end to the second end. Each of the plurality of optical fibers may be disposed with a substantially uniform angular orientation of the angular alignment features from the first end to the second end of the optical fibers. In this manner, as a non-limiting example, providing angular alignment of optical fibers relative to one another in the fiber optic ribbon cable may be less expensive relative to

conventional active alignment techniques involving substantially removing the ribbon matrix.

[0011] In another embodiment, a method for manufacturing a fiber optic ribbon cable is provided. The method includes providing a plurality of optical fibers. Each of the plurality of optical fibers includes an angular alignment feature extending from a first end of the plurality of optical fibers to a second end of the plurality of optical fibers. The method also includes aligning each of the plurality of optical fibers with respect to the angular alignment feature to provide uniform or substantially uniform angular orientation of each of the plurality of optical fibers downstream of an alignment surface to form a plurality of aligned optical fibers. The method further includes applying a ribbon matrix to the plurality of aligned optical fibers to produce a plurality of ribbonized optical fibers each comprising the uniform or substantially uniform angular orientation. In this manner, as a non-limiting example, the fiber optic ribbon cable may be adapted for passive alignment to a connector to avoid the time intensive process active alignment and substantially removing the ribbon matrix.

[0012] In another embodiment, a fiber optic ribbon cable is provided. The fiber optic ribbon cable may include a plurality of optical fibers. Each of the plurality of optical fibers may include a first end and a second end. Each of the plurality of optical fibers may also include an angular alignment feature extending from the first end to the second end. The angular alignment features may be formed as a portion of the external surface of the plurality of optical fibers. The fiber optic ribbon cable may also include ribbon matrix attached to each of the plurality of optical fibers with a ribbon die coating head. The ribbon matrix may be attached after each of the plurality of optical fibers may be aligned by abutting against an alignment surface. The ribbon matrix may extend from the first end of the optical fibers to the second end. Each of the plurality of optical fibers may be disposed with a substantially uniform angular orientation of the angular alignment features from the first end to the second end. In this manner, as a non-limiting example, the fiber optic ribbon cable may be optically coupled to a ferrule efficiently at an interconnection location. In this manner, as a non-limiting example, the fiber optic ribbon cable may provide multiple optical paths with less attenuation.

[0013] Additional features and advantages will be set forth in the detailed description which follows, and in part will be readily apparent to those skilled in the art from that description or recognized by practicing the embodiments as described herein, including the detailed description that follows, the claims, as well as the appended drawings.

[0014] It is to be understood that both the foregoing general description and the following detailed description present embodiments, and are intended to provide an overview or framework for understanding the nature and character of the disclosure. The accompanying drawings are included to provide a further understanding, and are incorporated into and constitute a part of this specification. The drawings illustrate various embodiments, and together with the description serve to explain the principles and operation of the concepts disclosed.

BRIEF DESCRIPTION OF THE FIGURES

[0015] **FIG. 1A** is an exemplary fiber optic ribbon cable having optical fibers being passively aligned into a ferrule of a fiber optic connector;

[0016] **FIG. 1B** is a front view of the ferrule of **FIG. 1A**;

[0017] **FIGS. 2A** and **2B** are a perspective view and a cross-sectional view of the fiber optic ribbon cable of **FIG. 1A**, including optical fibers with an angular alignment feature comprising a planar surface;

[0018] **FIG. 3** is a perspective view of an alignment surface used to facilitate alignment of the angular alignment features of the optical fibers of the fiber optic ribbon cable of **FIG. 1A**;

[0019] **FIG. 4A** is a perspective view of details of the optical fibers approaching the alignment surface of **FIG. 3** before being aligned by the alignment surface;

[0020] **FIG. 4B** is a perspective view of details of the optical fibers departing the alignment surface of **FIG. 3** in a uniform or substantially uniform angular alignment;

[0021] **FIG. 5** is a cross-sectional view of details of the optical fibers disposed in alignment in the fiber optic ribbon cable of **FIG. 2B**;

[0022] **FIG. 6** is a side view of the optical fibers and their angular alignment features abutting the alignment surface of **FIG. 3**;

[0023] FIG. 7 is a partial cutaway view of the optical fibers of FIG. 2A and their angular alignment features abutting against the alignment surface of FIG. 3;

[0024] FIG. 8 is a top view of the optical fibers and their angular alignment features abutting the alignment surface of FIG. 3;

[0025] FIG. 9A is a top view of an exemplary process of aligning the optical fibers including angular alignment features to manufacture the fiber optic ribbon cable of FIG. 1A;

[0026] FIG. 9B is a side view of the exemplary production line of FIG. 9A;

[0027] FIG. 10 is a side view of the ribbon die coating head of the process of FIGS. 9A and 9B; and

[0028] FIG. 11 is a cross-sectional view of an alternative embodiment of a fiber optic ribbon cable comprising optical fibers having angular alignment features including concave surfaces.

DETAILED DESCRIPTION

[0029] Reference will now be made in detail to the embodiments, examples of which are illustrated in the accompanying drawings, in which some, but not all embodiments are shown. Indeed, the concepts may be embodied in many different forms and should not be construed as limiting herein; rather, these embodiments are provided so that this disclosure will satisfy applicable legal requirements. Whenever possible, like reference numbers will be used to refer to like components or parts.

[0030] Embodiments disclosed herein include angular alignment of optical fibers for fiber optic ribbon cables and related methods. Multiple optical fibers disposed in parallel in a ribbon matrix may be used to increase bandwidth between two interconnection points. In this regard, optical fibers are angularly aligned during the process of forming a fiber optic ribbon cable. To angularly align the optical fibers, each of the optical fibers may include an angular alignment feature. The angular alignment feature facilitates uniform or substantially uniform angular orientation along a cable center axis of each of the optical fibers when the optical fibers are prepared to be disposed in the ribbon matrix to form a fiber optic ribbon cable. The uniform or substantially uniform angular orientation may facilitate alignment of each of the optical fibers as part of a process to optically connect each of these optical fibers precisely to a fiber optic connector. The optical fibers are held in angular alignment when provided in the ribbon matrix.

[0031] By purposefully aligning the optical fibers along their length during the formation of the fiber optic ribbon cable, the end portions of the optical fibers are aligned in the ribbon matrix. Thus, end portions of the ribbon matrix are not required to be removed (e.g., stripped or cut back) to expose and align the end portions of optical fibers when the ribbon cable is connectorized. Removing the end portions of the ribbon matrix incurs additional manufacturing labor and time, and associated expense. Also, having to expose lengths of the end portions of the optical fibers from the ribbon matrix for alignment can provide a greater risk damaging the optical fibers during connectorization.

[0032] In this regard, **FIG. 1A** shows an exemplary fiber optic ribbon cable **10** adapted for a passive alignment with a ferrule **12** of a fiber optic connector (not shown). The fiber optic ribbon cable **10** includes optical fibers **14(1)-14(N)** embedded within a ribbon matrix **16** and angularly aligned to be precisely received into orifices **18(1)-18(N)**

of the ferrule **12** respectively as shown in **FIG. 1B**. As will be discussed in more detail below, the optical fibers **14(1)-14(N)** contain angular alignment features **20(1)-20(N)** (**FIG. 2B**) that facilitate alignment of the optical fibers **14(1)-14(N)** to enable the fiber optic ribbon cable **10** to be more efficiently optically coupled at an interconnect location, for example where the ferrule **12** of a fiber optic connector may be located.

[0033] The fiber optic ribbon cable **10** may extend at least from a first end **22** to a second end **24**. The fiber optic ribbon cable **10** may extend, for example, more than a kilometer between the first end **22** and the second end **24**, to decrease manufacturing cost through economies of scale. The ribbon matrix **16** has been cut back at the second end **24** of the fiber optic ribbon cable **10** to expose a portion **26** of the optical fibers **14(1)-14(N)**. The portion **26** of the optical fibers **14(1)-14(N)** may be received by orifices **18(1)-18(N)** of the ferrule **12**. The ferrule **12** may be part of a fiber optic connector (not shown) and used within a process called passive alignment. In passive alignment, the optical fibers **14(1)-14(N)** may be precisely aligned by abutting mechanical interfaces of the ferrule **12**. Here, as shown in **FIG. 1B**, the mechanical interfaces are inner surfaces **28(1)-28(N)** forming the orifices **18(1)-18(N)**. Passive alignment is generally easier than active alignment where ends of optical fibers are precisely moved in three axes (X, Y, and Z) to perform an individual alignment of each optical fiber at an interconnection location using time-consuming optical diagnostic equipment before attaching the aligned optical fiber at the interconnection location.

[0034] Passive alignment of optical fibers **14(1)-14(N)** of the fiber optic ribbon cable **10** may be possible if the optical fibers **14(1)-14(N)** are angularly aligned within the ribbon matrix **16**. Passive alignment may not be feasible when the optical fibers **14(1)-14(N)** are not within a specific angular orientation. The angular orientation for each of the optical fibers must be maintained all along a length of the fiber optic ribbon cable **10** when manufactured to enable passive alignment at any cross-section required along the length.

[0035] To further describe the angular alignment of the optical fibers **14(1)-14(N)** using the angular alignment features **20(1)-20(N)** provided on the optical fibers **14(1)-14(N)**, **FIGS. 2A and 2B** are provided. **FIGS. 2A and 2B** are perspective and cross-sectional views of the fiber optic ribbon cable **10**. Each of the optical fibers **14(1)-14(N)**

of the fiber optic ribbon cable **10** shown in **FIGS. 2A-2B** may comprise, for example, a multicore optical fiber including optical cores **30**. Each of the optical cores **30** may be configured to accommodate different optical paths and thereby increase bandwidth of the fiber optic ribbon cable **10**. As there may not be merely a single optical core **30** at each fiber center axis $A_2(1)$ - $A_2(N)$ of the optical fibers **14(1)**-**14(N)** respectively when multicore optical fibers are utilized, angular orientation of each of the optical fibers **14(1)**-**14(N)** may be important when aligning to the ferrule **12**. If any of the optical fibers **14(1)**-**14(N)** are angularly misaligned at the ferrule **12**, then optical coupling at the ferrule **12** may be unsuccessful.

[0036] As shown in **FIG. 2B**, a cross section **X(2)** may include a portion of each of the plurality of optical fibers **14(1)**-**14(N)**, and the portions of each of the optical fibers **14(1)**-**14(N)** may be disposed in a geometric line (represented by vector Z_0) within the cross-section **X(2)**. Including portions of each optical fiber **14(1)**-**14(N)** at the cross section **X(2)** allows for any of these optical fibers **14(1)**-**14(N)** to be available for passive alignment to the ferrule **12** at this cross section **X(2)**.

[0037] **FIG. 2B** shows an angular alignment feature **20(1)**-**20(N)** of each of the optical fibers **14(1)**-**14(N)** respectively. Each of the angular alignment features **20(1)**-**20(N)** may be used to align the optical fibers **14(1)**-**14(N)** by abutting against an alignment surface **32** as shown in **FIG. 3**. The angular alignment features **20(1)**-**20(N)** facilitate the optical fibers **14(1)**-**14(N)** to also become aligned optical fibers **15(1)**-**15(N)** when engaged with the alignment surface **32**. The alignment may occur by applying tensile forces $F_T(1)$ - $F_T(N)$ on the optical fibers **14(1)**-**14(N)** respectively to thereby engage the alignment surface **32**. The alignment surface **32** may include, for example, a convex surface **34** (**FIG. 3**). The convex surface **34** permits the optical fibers **14(1)**-**14(N)** to engage with and disengage from the alignment surface **32** in a predictable and gradual manner.

[0038] **FIGS. 4A** and **4B** show the effectiveness of the alignment surface **32** on the angular alignment of the optical fibers **14(1)**-**14(N)**. As shown in **FIG. 4A**, the optical fibers **14(1)**-**14(N)** approach the alignment surface **32** with a velocity V_2 and random angular orientation as represented by angular vectors $Z_1(1)$ - $Z_1(N)$ pointing in different directions. **FIG. 4B** shows the optical fibers **14(1)**-**14(N)** departing from the alignment

surface **32** with the angular vectors $Z_1(1)$ - $Z_1(N)$ aligned in the same direction and ready to be fixed in this aligned angular position by the ribbon matrix **16** (**FIG. 2B**). As such, each of the optical fibers **14(1)**-**14(N)** may be disposed with a uniform or substantially uniform angular orientation of the angular alignment features **20(1)**-**20(N)** from the first end **22** to the second end **24** of the optical fibers **14(1)**-**14(N)**. Once the ribbon matrix **16** may be attached to the optical fibers **14(1)**-**14(N)**, the optical fibers **14(1)**-**14(N)** are aligned and ready for passive alignment with the ferrule **12**. The inefficiencies related to active alignment and substantial cut back of the ribbon matrix **16** may thereby be avoided.

[0039] Passive alignment of the fiber optic ribbon cable **10** and the concept of the alignment surface **32** to align the optical fibers **14(1)**-**14(N)** of the fiber optic ribbon cable **10** have been introduced. Now the details of the fiber optic ribbon cable **10** will be discussed before details of the alignment surface **32** and its use.

[0040] With reference back to **FIGS. 2A** and **2B**, the fiber optic ribbon cable **10** may include a plurality of optical fibers **14(1)**-**14(N)** and the ribbon matrix **16**, both extending from the first end **22** to the second end **24** along a cable center axis A_1 . The plurality of optical fibers **14(1)**-**14(N)** may include fiber center axes $A_2(1)$ - $A_2(N)$, respectively, which may be parallel to the cable center axis A_1 . The number **N** (or quantity) of optical fibers **14(1)**-**14(N)** may depend on the application, and although at least three (3) are shown in **FIG. 1B** it is noted that two (2) are also possible but not shown.

[0041] The optical fibers **14(1)**-**14(N)** may be attached to each other through the ribbon matrix **16**. The ribbon matrix **16** may be made of a strong, flexible material, for example, a polyurethane acrylate resin commercially available from DSM Desotech Inc. of Elgin, Illinois.

FIG. 5 depicts the cross-section $X(2)$ of optical fiber **14(1)** which also may represent optical fibers **14(1)**-**14(N)** to simplify discussion herein. It is noted that this cross-section $X(2)$ may be orthogonal to the fiber center axis $A_2(1)$. The optical fibers **14(1)**-**14(N)** may include bare optical fibers **36(1)**-**36(N)** and primary coatings **38(1)**-**38(N)**, respectively. The primary coatings **38(1)**-**38(N)** may surround the bare optical fibers **36(1)**-**36(N)** to form external surfaces **40(1)**-**40(N)** of the optical fibers **14(1)**-**14(N)**, respectively. The bare optical fibers **36(1)**-**36(N)** may comprise a strong material with

excellent optical properties, for example, silica glass. The primary coatings **38(1)-38(N)** may prevent surface abrasions from forming on the bare optical fibers **36(1)-36(N)**. Surface abrasions may be created when the bare optical fibers **36(1)-36(N)** contact other objects, for example, the alignment surface **32**. The surface abrasions may weaken the bare optical fibers **36(1)-36(N)** and thereby damage or break the bare optical fibers **36(1)-36(N)**. The primary coatings **38(1)-38(N)** prevent surface abrasions from being created and thereby protect the bare optical fibers **36(1)-36(N)**. The primary coatings **38(1)-38(N)** may comprise, for example, ultra-violet (UV) curable acrylate.

[0042] With continuing reference to **FIG. 5**, details and significance of the cross-sectional shape of the optical fibers **14(1)-14(N)** will be discussed. Each of the optical fibers **14(1)-14(N)** may be formed with the external surface **40(1)-40(N)** generally disposed around the center axis **A₂(1)-A₂(N)** respectively. The optical fibers **14(1)-14(N)** may each include the angular alignment feature **20(1)-20(N)**, respectively, extending from the first end **22** to the second end **24** to ensure alignment along a length of the fiber optic ribbon cable **10**.

[0043] It is noted that the primary coatings **38(1)-38(N)** may be relatively thin, for example five (5) to ten (10) microns, in order to not obscure a contribution of the bare optical fibers **36(1)-36(N)** to the angular alignment features **20(1)-20(N)** when engaging the alignment surface **32** and thereby “blur” or make less effective the alignment of the optical fibers **14(1)-14(N)** at the alignment surface **32**.

[0044] Each of the angular alignment features **20(1)-20(N)** may be aligned parallel to the cable center axis **A₁** and extend from a first transition point **42(1)-42(N)** to a second transition point **44(1)-44(N)** along a portion of the external surfaces **40(1)-40(N)** of the optical fibers **14(1)-14(N)**. The first transition point **42(1)-42(N)** and the second transition point **44(1)-44(N)** provide stability to the alignment process by preventing the angular alignment feature **20(1)-20(N)** from disengaging from the alignment surface **32**.

[0045] A concentric portion **46(1)-46(N)** of the external surfaces **40(1)-40(N)**, not containing the angular alignment feature **20(1)-20(N)**, may be generally be concentric to the fiber center axis **A₂(1)-A₂(N)**. The concentricity permits the optical fiber **14(1)-14(N)** to more easily turn upon the alignment surface **32** towards the angular alignment features **20(1)-20(N)** respectively. It is noted that the angular alignment features **20(1)-20(N)** are

closer to the fiber center axis $A_2(1)-A_2(N)$ of each optical fiber $14(1)-14(N)$ than the concentric portion $46(1)-46(N)$. As such, each of the concentric portions $46(1)-46(N)$ of the optical fibers $14(1)-14(N)$ may rotate upon the alignment surface 32 , but eventually the angular alignment features $20(1)-20(N)$ may engage and abut against the alignment surface 32 to stop the rotation of the optical fibers $14(1)-14(N)$ and align the optical fibers $14(1)-14(N)$.

[0046] With continuing reference to **FIG. 5**, details of the angular alignment features $20(1)-20(N)$ will now be provided. Cross-sections $X(1)-X(N)$ of each of the optical fibers $14(1)-14(N)$ may include a planar surface $48(1)-48(N)$ of the angular alignment features $20(1)-20(N)$ respectively. The planar surface $48(1)-48(N)$ may be parallel to the fiber center axis $A_2(1)-A_2(N)$ and may extend from the first end 22 to the second end 24 of the fiber optic ribbon cable 10 (**FIG. 1A**) as well as from the first transition point $42(1)-42(N)$ to the second transition point $44(1)-44(N)$, respectively. The planar surface $48(1)-48(N)$ provides stability when the angular alignment feature $20(1)-20(N)$ is abutting the alignment surface 32 because the planar surface $48(1)-48(N)$ may be disposed closer to fiber center axis $A_2(1)-A_2(N)$ than the concentric portions $46(1)-46(N)$ as discussed above.

[0047] As shown in **FIG. 5**, a nominal diameter D_1 of each of the bare optical fibers $36(1)-36(N)$ may be, for example, one-hundred (100) microns. After the primary coatings $38(1)-38(N)$ may be applied, a nominal diameter D_2 of each of the optical fibers $14(1)-14(N)$ may be, for example, one-hundred twenty-five (125) microns. Each of the angular alignment features $20(1)-20(N)$ may be of a width W of at least forty (40) microns as measured in the cross-section $X(1)-X(N)$ (**FIG. 2A**) which may be orthogonal to the fiber center axis $A_2(1)-A_2(N)$. A width W less than forty (40) microns may not enable the angular alignment features $20(1)-20(N)$ to align the optical fibers $14(1)-14(N)$ upon the alignment surface 32 .

[0048] **FIGS. 6** and **7** provide details of the alignment of the optical fibers $14(1)-14(N)$ upon the alignment surface 32 . This alignment may provide the uniform or substantially uniform angular orientation of each of the plurality of optical fibers $14(1)-14(N)$ downstream of the alignment surface 32 to form the plurality of aligned optical fibers $15(1)-15(N)$. As shown in **FIGS. 6** and **7**, alignment is accomplished by utilizing

the tension force $F_T(1)-F_T(N)$ on each of the optical fibers $14(1)-14(N)$ to engage each of the angular alignment features $20(1)-20(N)$ with the alignment surface 32 . In this regard, both the first transition point $42(1)-42(N)$ and the second transition point $44(1)-44(N)$ (**FIG. 5**) of the angular alignment features $20(1)-20(N)$ may engage with the alignment surface 32 directly or through the primary coatings $38(1)-38(N)$. Generally, each of the optical fibers $14(1)-14(N)$ may maintain a constant angular orientation with respect to the alignment surface 32 as long as a sufficient amount of the tension force $F_T(1)-F_T(N)$ may be applied to each of the optical fibers $14(1)-14(N)$ to maintain both the first transition point $42(1)-42(N)$ and the second transition point $44(1)-44(N)$ in communication with the alignment surface 32 .

[0049] **FIGS. 6** and **7** show the relationship between the tension force $F_T(1)-F_T(N)$ and the force F_R placed on the optical fibers $14(1)-14(N)$ to keep the optical fibers $14(1)-14(N)$ engaged with the alignment surface 32 . The optical fibers $14(1)-14(N)$ may approach the alignment surface 32 at a theta angle θ_1 (theta 1) with a tension force $F_T(1)-F_T(N)$, respectively. The retaining force F_R applied to the optical fibers $14(1)-14(N)$ by the alignment surface 32 may be calculated as: $F_R(N) = 2 * [F_T(N)] * \sin(\text{theta angle } \theta_1/2)$, for values of the theta angle θ_1 from zero (0) to up to one-hundred eighty (180) degrees. In this regard, the retaining force F_R may generally be increased by elevating the tension force $F_T(N)$ and/or the theta angle θ_1 . The higher retaining force F_R may be associated with a more uniform angular orientation because the first transition point $42(1)-42(N)$ and second transition point $44(1)-44(N)$ are pulled in a direction toward the alignment surface 32 (**FIG 6**). The theta angle θ_1 may be, for example, up to about one-hundred seventy (170) degrees and may be ninety (90) degrees to optimize the retaining force F_R and minimize stress on the optical fibers $14(1)-14(N)$.

[0050] With continuing reference to **FIG. 6**, a radius r (or radius of curvature) of the alignment surface 32 may also be adjusted, for example, to not damage the optical fibers $14(1)-14(N)$ and/or to increase local pressure of the retaining force F_R on the optical fibers $14(1)-14(N)$. The optical fibers $14(1)-14(N)$ may have a minimum bend radius of curvature to prevent damage to the optical fibers $14(1)-14(N)$, for example, five (5) millimeters. The radius r of the alignment surface 32 may be constructed to at least be

greater than the minimum bend radius of the optical fibers **14(1)-14(N)**. However, a larger value of the radius **r** of the alignment surface **32** may distribute the retaining force **F_R** over a larger area **52** (**FIG. 6**) of the alignment surface **32** and thereby the retaining force **F_R** allocated to at any one portion of the optical fibers **14(1)-14(N)** may be less. The resulting consequence is that there may be generally less control of the uniformity of the angular orientation of the optical fibers **14(1)-14(N)**. The radius **r** of the alignment surface **32** may be, for example, six (6) inches.

[0051] The alignment surface **32** may or may not rotate. **FIG. 6** also shows the convex surface **34** of the alignment surface **32** rotating with a rotational speed **V₁** about a rotational axis **A₃**. The rotational speed **V₁** may reduce the chance for damage to the optical fibers **14(1)-14(N)** by reducing friction **F_F** between the optical fibers **14(1)-14(N)** and the alignment surface **32**. The convex surface **34** may be concentric about the rotational axis **A₃** to minimize disturbance of the abutment of the optical fibers **14(1)-14(N)** against the alignment surface **32** as shown in **FIG. 7**.

[0052] As shown in **FIG. 8**, the optical fibers **14(1)-14(N)** may be disposed at a second theta angle **θ₂** with respect to the rotational axis **A₃**. The second theta angle **θ₂** may be within five (5) degrees of orthogonal. A value of the second theta angle **θ₂** of ninety (90) degrees may prevent a movement of the alignment surface **32** not parallel to the center axis **A₂(1)-A₂(N)** of the optical fibers **14(1)-14(N)** from disengaging one or more of the angular alignment features **20(1)-20(N)** from the alignment surface **32**.

[0053] **FIG. 9A** is a top view of an exemplary production line **54** utilizing an exemplary process **56** of aligning the optical fibers **14(1)-14(N)** including the angular alignment features **20(1)-20(N)** to manufacture the fiber optic ribbon cable **10**. **FIG. 9B** further shows the exemplary production line **54** in a side view. The process **56** in **FIGS. 9A** and **9B** will be described using the terminology and information provided above.

[0054] A first step **58** in the process **56** may be to provide the plurality of optical fibers **14(1)-14(N)** (step **58** in **FIG. 9A**). Each of the plurality of optical fibers **14(1)-14(N)** may include the angular alignment feature **20(1)-20(N)**, respectively. The optical fibers **14(1)-14(N)** may be provided, for example, on spool-enabled devices **60(1)-60(N)** adapted to pay out the optical fibers **14(1)-14(N)** and maintain a tension force **F_T(1)-**

$F_T(N)$ on each of the optical fibers **14(1)-14(N)**. The tension force $F_T(1)-F_T(N)$ may be, for example, in a range from one (1) to two (2) pounds applied to each of the optical fibers **14(1)-14(N)**. However, the tension force $F_T(1)-F_T(N)$ may be experimentally adjusted to meet the specific specifications of the optical fibers **14(1)-14(N)** and the production line **54**.

[0055] Next, the optical fibers **14(1)-14(N)** may be routed through an aerial pathway **62** (FIGS. **9A-9B**) to the alignment surface **32**, for example, as shown in FIG. **3** (step **64** in FIG. **9A**). The aerial pathway **62** (FIGS. **9A-9B**) may be adapted to store angular twists of the optical fibers **14(1)-14(N)** and help prevent these angular twists from traveling downstream of the alignment surface **32** by providing a location for the angular twists to be stored. A close-up image in FIG. **4A** shows exemplary angular twists represented by the angular alignment features **20(1)-20(3)** of optical fibers **14(1)-14(3)** respectively at different angular vectors $V_1(1)-V_1(3)$ approaching the alignment surface **32** than when departing the alignment surface **32** in FIG. **4B**. The angular change of each of the optical fibers **14(1)-14(N)** between FIG. **4A** and **4B** are the angular twists which may be stored in the aerial pathway **62**.

[0056] With reference back to FIG. **9A**, in order to store these angular twists, the aerial pathway **62** includes a distance L_1 selected sufficiently large to be able to store an adequate quantity of angular twists, so that a torque does not build to a threshold level upstream of the alignment surface **32**. Each of the optical fibers **14(1)-14(N)** may perform as a torsion spring and increase torsion with every angular twist that may be stored. If the torsion stored in any of the optical fibers **14(1)-14(N)** within the aerial pathway **62** exceeds the threshold level, the corresponding member of the optical fibers **14(1)-14(N)** may disengage from the alignment surface **32** and the angular twists stored in the aerial pathway **62** may escape downstream of the alignment surface **32** to become embedded in the fiber optic ribbon cable **10** and thereby reduce the uniformity of the angular orientation. The length L_1 may be, for example, thirty (30) feet long.

[0057] It is further noted that the threshold level may be determined experimentally while considering several factors, including, for example, dimensional and material characteristics the optical fibers **14(1)-14(N)**, the tension force $F_T(1)-F_T(N)$, and material

characteristics of the alignment surface **32**. Further, the length L_1 may be reduced by better controlling twist during a manufacture of the optical fibers **14(1)-14(N)**.

[0058] Next, each of the plurality of optical fibers **14(1)-14(N)** may be aligned with respect to the angular alignment feature **20(1)-20(N)** (step **66** in **FIG. 9A**). The details of the alignment of the optical fibers **14(1)-14(N)** against the alignment surface **32** were discussed above with respect to at least **FIGS. 6-7** and is not repeated here to reduce redundancy.

[0059] Next, the ribbon matrix **16** may be applied to the aligned optical fibers **15(1)-15(N)** to produce ribbonized optical fibers **68(1)-68(N)** where each comprises the substantially uniform angular orientation (step **70** in **FIG. 9A**). The ribbon matrix **16** may be applied with a ribbon die coating head **72**.

[0060] **FIG. 10** shows a side view of an example of the ribbon die coating head **72**. The aligned optical fibers **15(1)-15(N)** are routed to the ribbon die coating head **72** over a distance L_2 from the alignment surface **32** (**FIG. 9A**). The distance L_2 may be kept as short as possible to minimize the opportunity for the aligned optical fibers **15(1)-15(N)** to change angular orientation. The length L_2 may be, for example, eight (8) inches as a non-limiting example.

[0061] A material supply **74** for the ribbon matrix **16** may be provided to the ribbon die coating head **72**. A fiber inlet **76** of the ribbon die coating head **72** allows aligned optical fibers **15(1)-15(N)** to enter a die head chamber **78**. A material inlet **80** of the ribbon die coating head **72** may allow a matrix material flow MMF_1 from the material supply **74** to enter the die head chamber **78** from the material supply **74**. An outlet **82** may be disposed so that ribbonized optical fibers **68(1)-68(N)**, which include the aligned optical fibers **15(1)-15(N)**, may exit the die head chamber **78**.

[0062] With continuing reference to **FIGS. 9A** and **9B**, next, the ribbonized optical fibers **68(1)-68(N)** may then be cured to produce the fiber optic ribbon cable **10** by entering an oven **84** which may be, for example, an ultra-violet (UV) curing oven (step **86** in **FIG. 9A**). It is noted that the oven **84** may not be required if materials utilized for the ribbon matrix **16** do not require the oven **84**. Also it is noted that the oven **84** may be formed integral with the ribbon die coating head **72**.

[0063] Next, the fiber optic ribbon cable **10** may be then sent to a marking device **88** (step **90** in **FIG. 9A**). The marking device **88** may be used to add identification markings to the fiber optic ribbon cable **10**. Next, the fiber optic ribbon cable **10** may be then wound onto a take up reel **92** (step **94** in **FIG. 9A**). The take up reel **92** may be used to transport the fiber optic ribbon cable **10** to a facility for connectorization where passive alignment may occur with the ferrule **12**.

[0064] The fiber optic ribbon cable **10** may be produced with the exemplary process **56** provided above. The fiber optic ribbon cable **10** may include the plurality of optical fibers **14(1)-14(N)**. Each of optical fibers **14(1)-14(N)** may include the first end **22** and the second end **24**. Each of the optical fibers **14(1)-14(N)** may also include the angular alignment feature **20(1)-20(N)**, respectively, extending from the first end **22(1)-22(N)** to the second end **24(1)-24(N)**. The angular alignment features **20(1)-20(N)** may be formed as the portion of the bare optical fibers **36(1)-36(N)** of the optical fibers **14(1)-14(N)**. The fiber optic ribbon cable **10** may also include the ribbon matrix **16** attached to each of the optical fibers **14(1)-14(N)** with the ribbon die coating head **72**. The ribbon matrix **16** may be attached after each of the optical fibers **14(1)-14(N)** may be aligned by abutting against the alignment surface **32**. The ribbon matrix **16** may extend from the first end **22** of the optical fibers **14(1)-14(N)** to the second end **24**. Each of the optical fibers **14(1)-14(N)** may be disposed with a substantially uniform angular orientation of the angular alignment features **20(1)-20(N)** from the first end **22** to the second end **24**.

[0065] **FIG. 11** shows a second embodiment of the optical fiber **14-2(1)-14-2(N)** of a fiber optic ribbon cable **10(2)**. One or more of the optical fibers **14-2(1)-14-2(N)** may include angular alignment features **20-2(1)-20-2(N)** comprising a concave surface **96(1)-96(N)**. The concave surface **96(1)-96(N)** may be configured to be aligned parallel to fiber center axes **A₂(1)-A₂(N)** respectively. All other characteristics of the optical fibers **14-2(1)-14-2(N)** may be similar to those of the optical fibers **14(1)-14(N)** discussed earlier in association with **FIG. 5** and will not be repeated for conciseness and to reduce redundancy. The concave surface **96(1)-96(N)** may be connected to a remainder of the external surface **40(1)-40(N)** at the first transition point **42(1)-42(N)** and the second transition point **44(1)-44(N)**. The first transition point **42(1)-42(N)** and the second transition point **44(1)-44(N)** together may permit a more robust alignment because an

abutment between the angular alignment feature **20-2(1)-20-2(N)** and the alignment surface **32** may be limited to the first transition point **42(1)-42(N)** and the second transition point **44(1)-44(N)**. Thereby surface imperfections of the angular alignment feature **20-2(1)-20-2(N)** between the first transition point **42(1)-42(N)** and the second transition point **44(1)-44(N)** may be avoided.

[0066] Lastly, terminology regarding alignment of the optical fibers **14(1)-14(N)** within the fiber optic ribbon cable **10** is discussed. Alignment of the optical fibers **14(1)-14(N)** within the fiber optic ribbon cable **10** is a measurable characteristic. Uniform angular orientation exists for the purposes of this disclosure when none of the optical fibers **14(1)-14(N)** twist along their path between the first end **22** and the second end **24** of the fiber optic ribbon cable **10**. This measurable characteristic excludes twisting of the optical fibers **14(1)-14(N)** attributable to the fiber optic ribbon cable **10** not being extended straight. Specifically, uniform angular orientation exists where an angular relationship between a datum angular vector Z_0 and the angular vector Z_1 of any cross-section **X(1)-X(N)** remains unchanged relative to any other random cross-sections **X(1)-X(N)** between the first end **22** and the second end **24** (**FIG. 2A**). The datum angular vector Z_0 may be analogous to a datum and may be defined as intersecting any two of the fiber center axes **A₂(1)-A₂(N)**. For example, in **FIG. 2B** a vector Z_0 is defined as intersecting the fiber center axis **A₂(1)** and extending to the fiber axis **A₂(N)**. When determining uniform orientation between different ones of the cross-sections **X(1)-X(N)**, the same selected members of the fiber center axes **A₂(1)-A₂(N)** are used in order to establish a standard datum.

[0067] The angular vector Z_1 may be defined as extending from the first transition point **42(1)-42(N)** of the optical fiber **14(1)-14(N)** of interest to the second transition point **44(1)-44(N)** of the same optical fiber **14(1)-14(N)** of interest. As long as the angular relationship (or angle) between the datum angular vector Z_0 and the angular vector Z_1 is the same for a given cross-section **X(1)** compared to all cross-sections **X(2)-X(N)** between the first end **22** and the second end **24** for the optical fiber **14(N)** of the optical fibers **14(1)-14(N)**, then there is uniform angular orientation for that optical fiber **14(N)**. Substantial uniform angular orientation occurs for the fiber optic ribbon cable **10** when the angular orientation for all of the optical fibers **14(1)-14(N)** are analyzed

individually and the maximum angular difference between the datum angular vector Z_0 and the angular vector Z_1 is, for example, less than ten (10) degrees, or less than one (1) degree.

[0068] Further, as used herein, it is intended that terms “fiber optic cables” and/or “optical fibers” include all types of single mode and multi-mode light waveguides, including one or more optical fibers that may be upcoated, colored, buffered, ribbonized and/or have other organizing or protective structure in a cable such as one or more tubes, strength members, jackets or the like. The optical fibers disclosed herein can be single mode or multi-mode optical fibers. Likewise, other types of suitable optical fibers include bend-insensitive optical fibers, or any other expedient of a medium for transmitting light signals. An example of a bend-insensitive, or bend resistant, optical fiber is ClearCurve[®] Multimode fiber commercially available from Corning, Incorporated of Corning, New York. Suitable fibers of this type are disclosed, for example, in U.S. Patent Application Publication Nos. 2008/0166094 and 2009/0169163, the disclosures of which are incorporated herein by reference in their entireties.

[0069] Many modifications and other embodiments of the embodiments disclosed herein will come to mind to one skilled in the art to which the embodiments pertain having the benefit of the teachings presented in the foregoing descriptions and the associated drawings. Therefore, it is to be understood that the description and claims are not to be limited to the specific embodiments disclosed and that modifications and other embodiments are intended to be included within the scope of the appended claims. It is intended that the embodiments cover the modifications and variations of the embodiments provided they come within the scope of the appended claims and their equivalents. Although specific terms are employed herein, they are used in a generic and descriptive sense only and not for purposes of limitation.

We claim:

1. A fiber optic ribbon cable, comprising:
a plurality of optical fibers including a first end and a second end; and
a ribbon matrix attached to each of the plurality of optical fibers, the ribbon matrix extending from the first end to the second end,
wherein each of the plurality of optical fibers includes an angular alignment feature extending from the first end to the second end, each of the plurality of optical fibers is disposed with a uniform or substantially uniform angular orientation of the angular alignment features from the first end to the second end.
2. The fiber optic ribbon cable of claim 1, wherein each of the plurality of optical fibers comprises a bare optical fiber and a coating surrounding the bare optical fiber to form an external surface of the optical fiber, the external surface includes the angular alignment feature.
3. The fiber optic ribbon cable of claims 1 or 2, wherein a cross-section of each of the plurality of optical fibers includes a planar surface of the angular alignment feature.
4. The fiber optic ribbon cable of any one of claims 1-3, wherein the angular alignment feature includes a width of at least forty (40) microns in a cross-section.
5. The fiber optic ribbon cable of claim 1, wherein a cross-section of each of the plurality of optical fibers comprises a concave surface of the angular alignment feature, the concave surface is configured to be aligned parallel to a fiber center axis, the cross-section is orthogonal to the fiber center axis.
6. The fiber optic ribbon cable of claim 3, wherein the planar surface is parallel to a fiber center axis, and the cross-section is orthogonal to the fiber center axis.
7. The fiber optic ribbon cable of any one of claims 1-6, wherein a cross-section of the fiber optic cable includes a portion of each of the plurality of optical fibers, and the

portion of each of the optical fibers is disposed in a geometric line within the cross-section.

8. The fiber optic ribbon cable of claim 2, wherein the angular alignment features of the plurality of optical fibers are configured to be passively aligned with a ferrule.

9. The fiber optic ribbon cable of any one of claims 1-8, wherein each of the plurality of optical fibers comprises a multicore optical fiber including at least two cores, each of the at least two cores configured to accommodate different optical paths.

10. A method for manufacturing a fiber optic ribbon cable, comprising:

providing a plurality of optical fibers, each of the plurality of optical fibers including an angular alignment feature extending from a first end of the plurality of optical fibers to a second end of the plurality of optical fibers;

aligning each of the plurality of optical fibers with respect to the angular alignment feature to provide a uniform or substantially uniform angular orientation of each of the plurality of optical fibers downstream of an alignment surface to form a plurality of aligned optical fibers; and

applying a ribbon matrix to the plurality of aligned optical fibers to produce a plurality of ribbonized optical fibers each comprising the substantially uniform angular orientation.

11. The method of claim 10, wherein the providing the plurality of optical fibers comprises providing the plurality of optical fibers each with the angular alignment feature.

12. The method of claim 11, wherein the aligning each of the plurality of optical fibers comprises abutting the angular alignment feature of each of the plurality of optical fibers against the alignment surface.

13. The method of claim 12, wherein the angular alignment feature comprises a planar surface or a convex surface.
14. The method of claim 12, wherein the alignment surface comprises a convex surface rotating about an axis.
15. The method of claim 10, wherein the alignment surface rotates about the axis according to friction between the plurality of optical fibers and the alignment surface.
16. The method of claim 14, wherein the convex surface comprises a concentric surface about the axis, and each of the plurality of optical fibers approaches the alignment surface at an angle up to one-hundred seventy (170) degrees relative to an angle that the plurality of optical fibers departs the alignment surface.
17. The method of any one of claims 10-16, wherein each of the plurality of optical fibers comprises a multicore optical fiber including at least two cores, each of the at least two cores configured to accommodate different optical paths.
18. The method of any one of claims 10-17, wherein the angular alignment features of the plurality of optical fibers are configured to be passively aligned with a ferrule.

19. A fiber optic ribbon cable, comprising:

a plurality of optical fibers and each includes a first end and a second end, each of the plurality of optical fibers includes an angular alignment feature extending from the first end to the second end, the angular alignment features formed as a portion of an external surface of the plurality of optical fibers; and

a ribbon matrix attached to each of the plurality of optical fibers with a ribbon die coating head after each of the plurality of optical fibers is aligned by abutting against a rotating alignment surface, the ribbon matrix extending from the first end of the optical fibers to the second end,

wherein each of the plurality of optical fibers is disposed with a substantially uniform angular orientation of the angular alignment features from the first end to the second end.

20. The fiber optic ribbon cable of claim 19, wherein each of the plurality of optical fibers comprises a multicore optical fiber including at least two cores, each of the at least two cores configured to accommodate different optical paths.

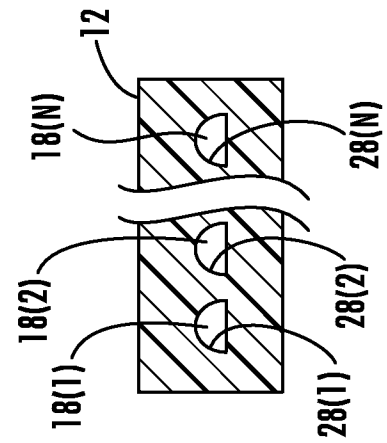
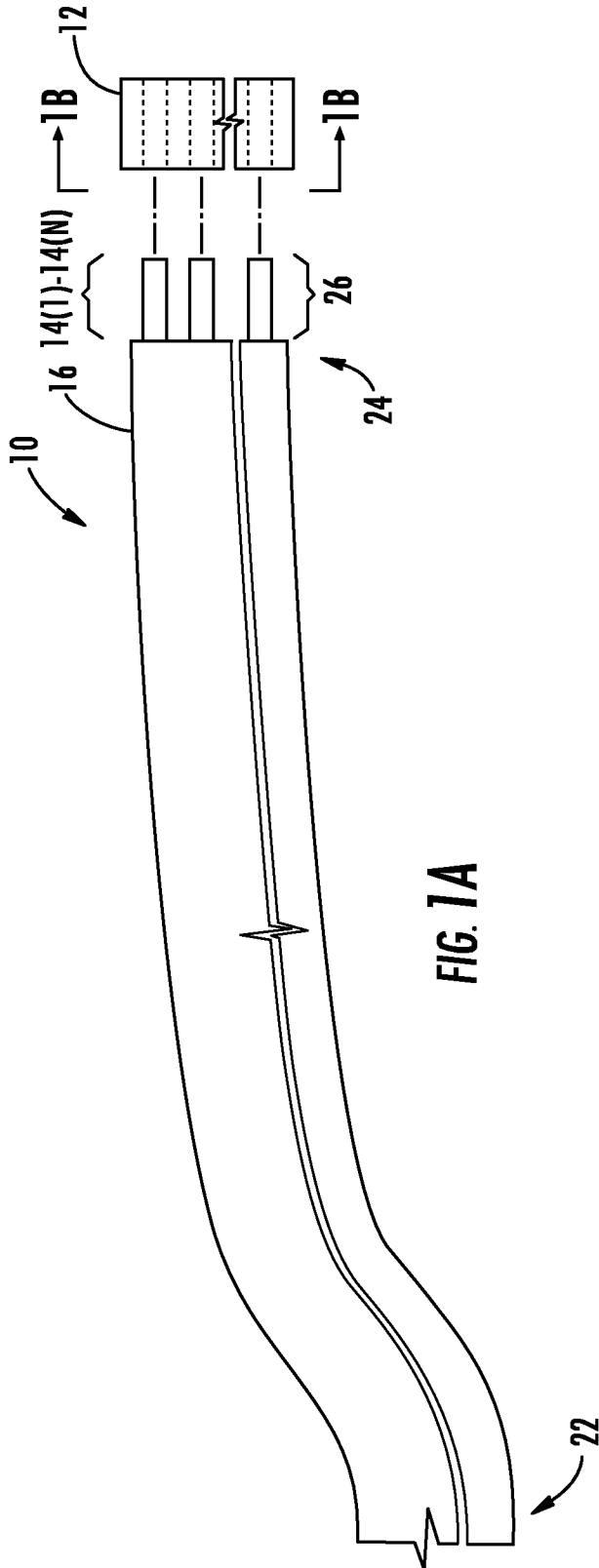

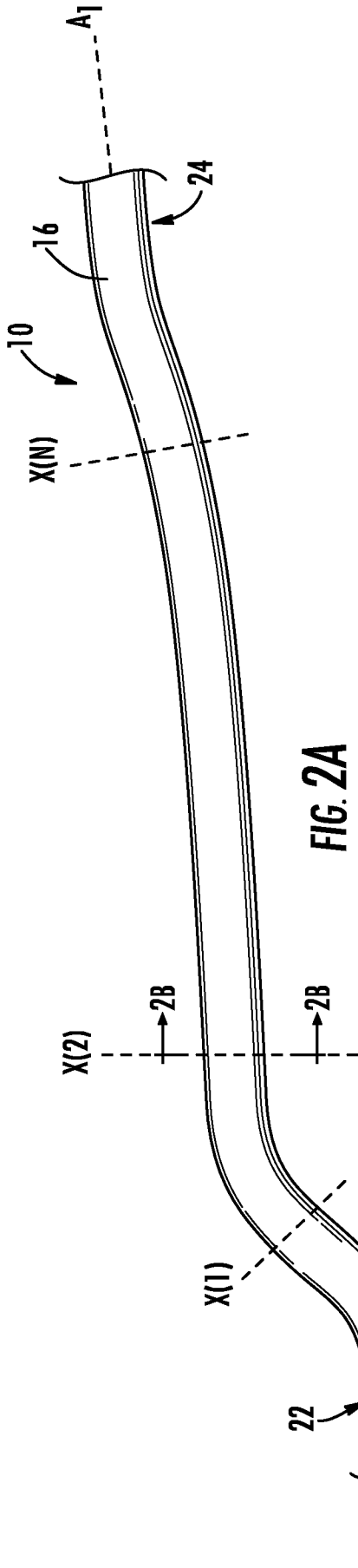

FIG. 2A

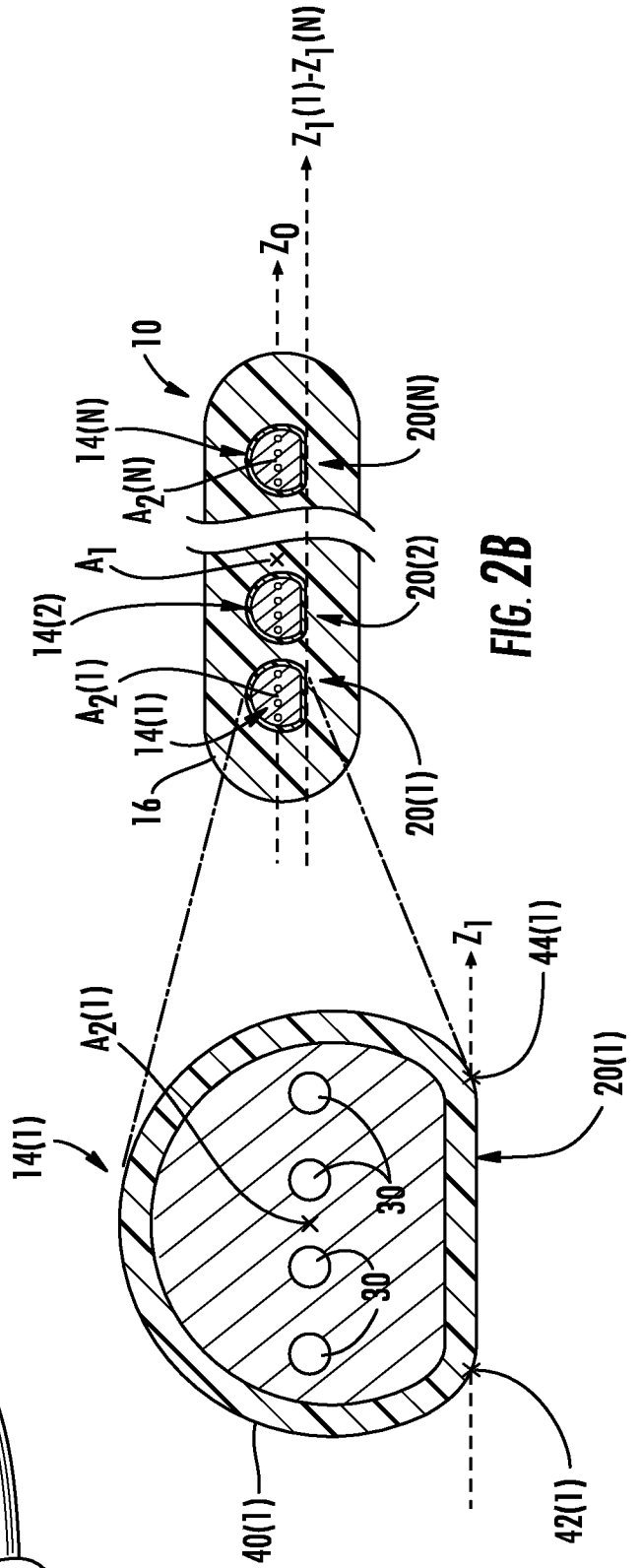

FIG. 2B

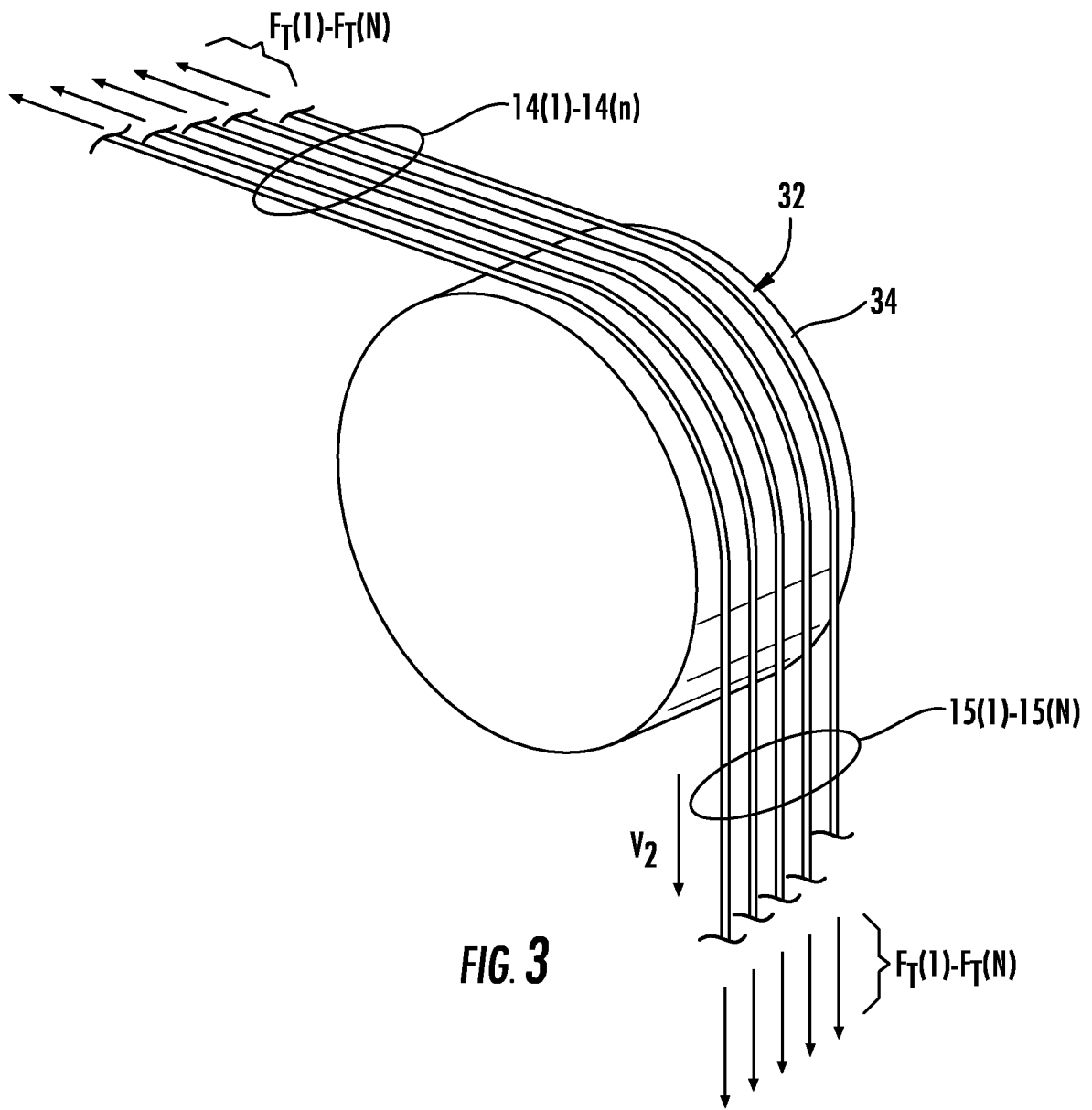
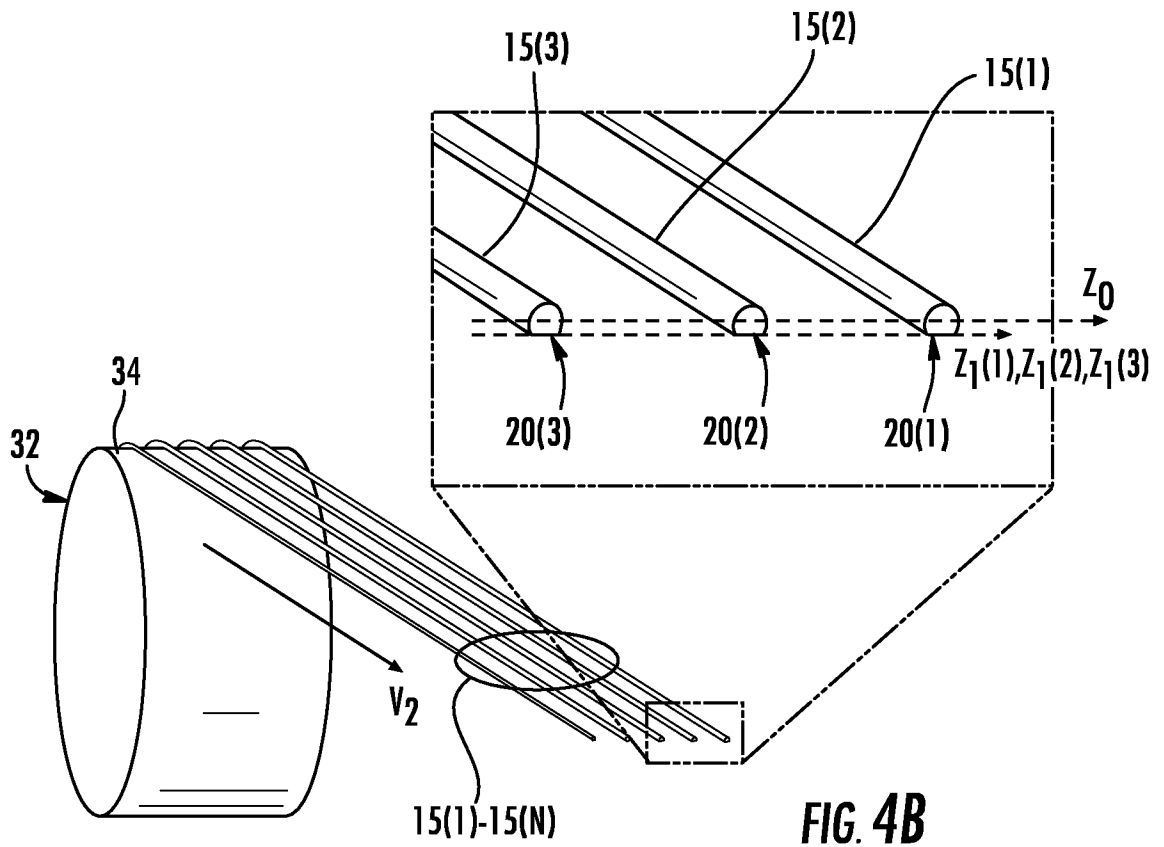
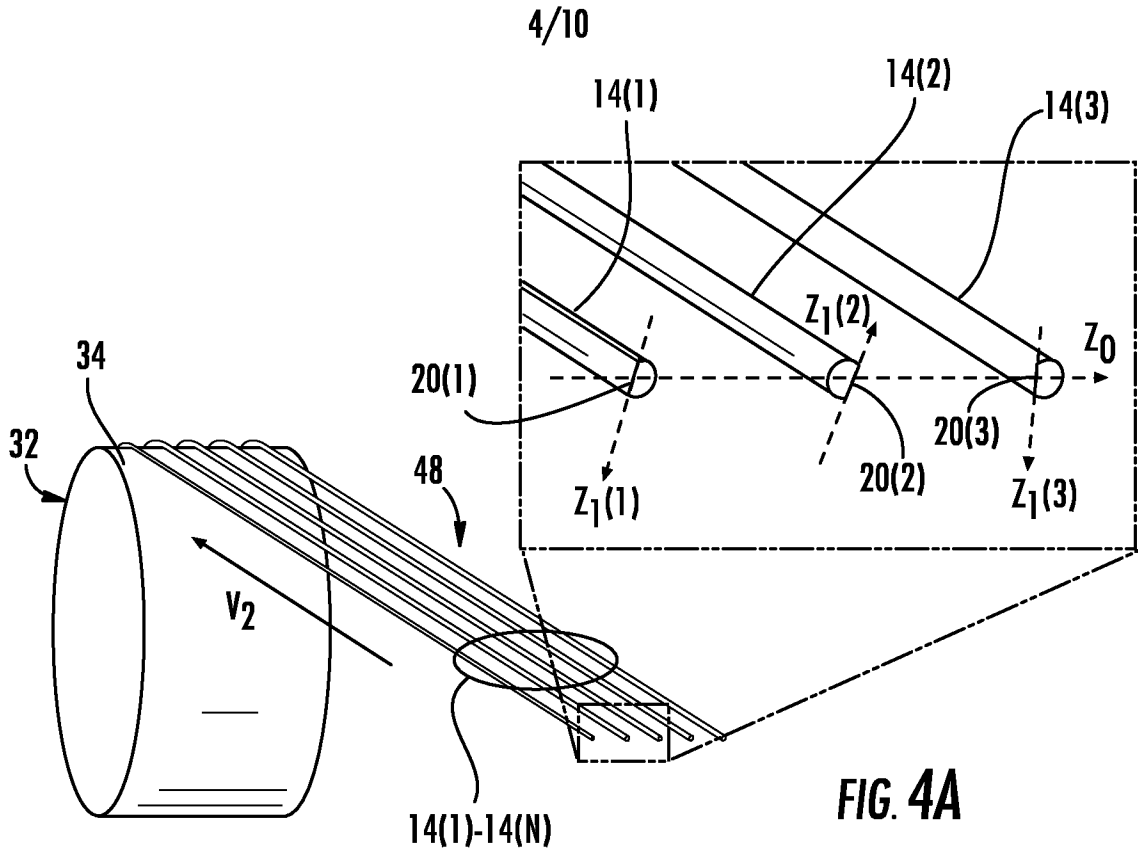

FIG. 3



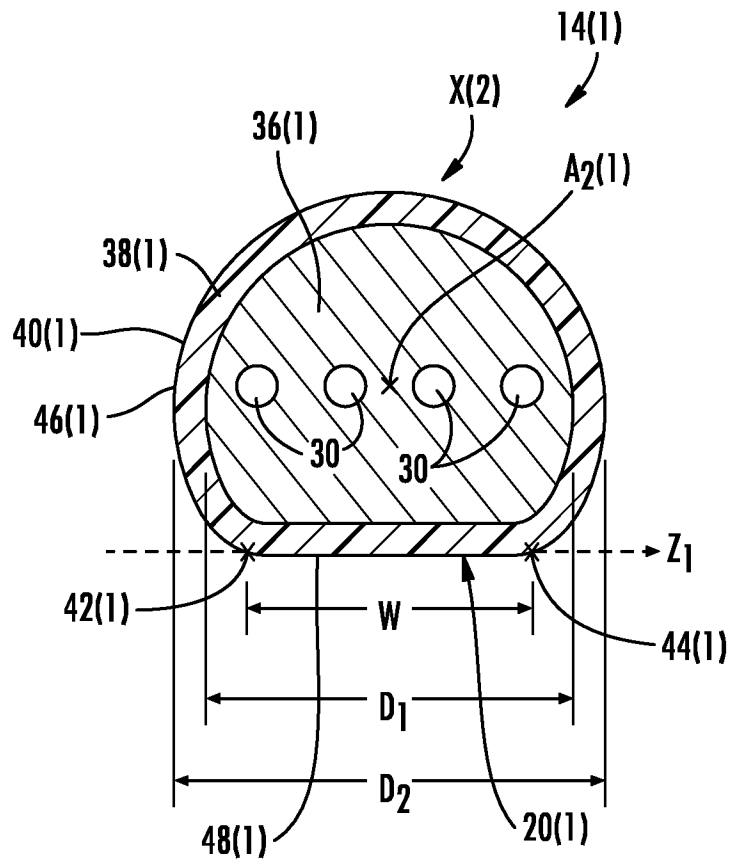

FIG. 5

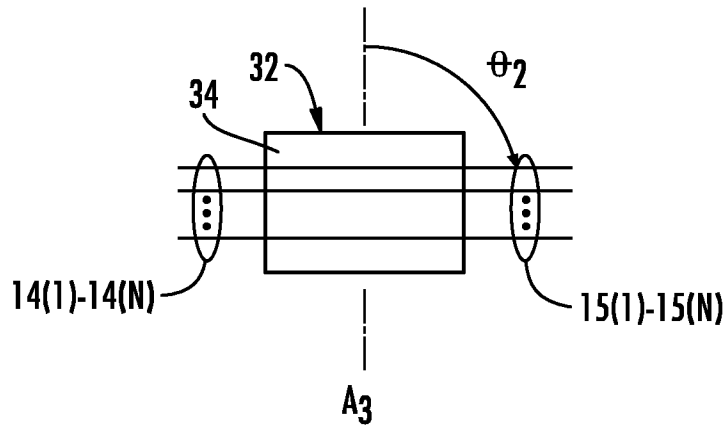

FIG. 8

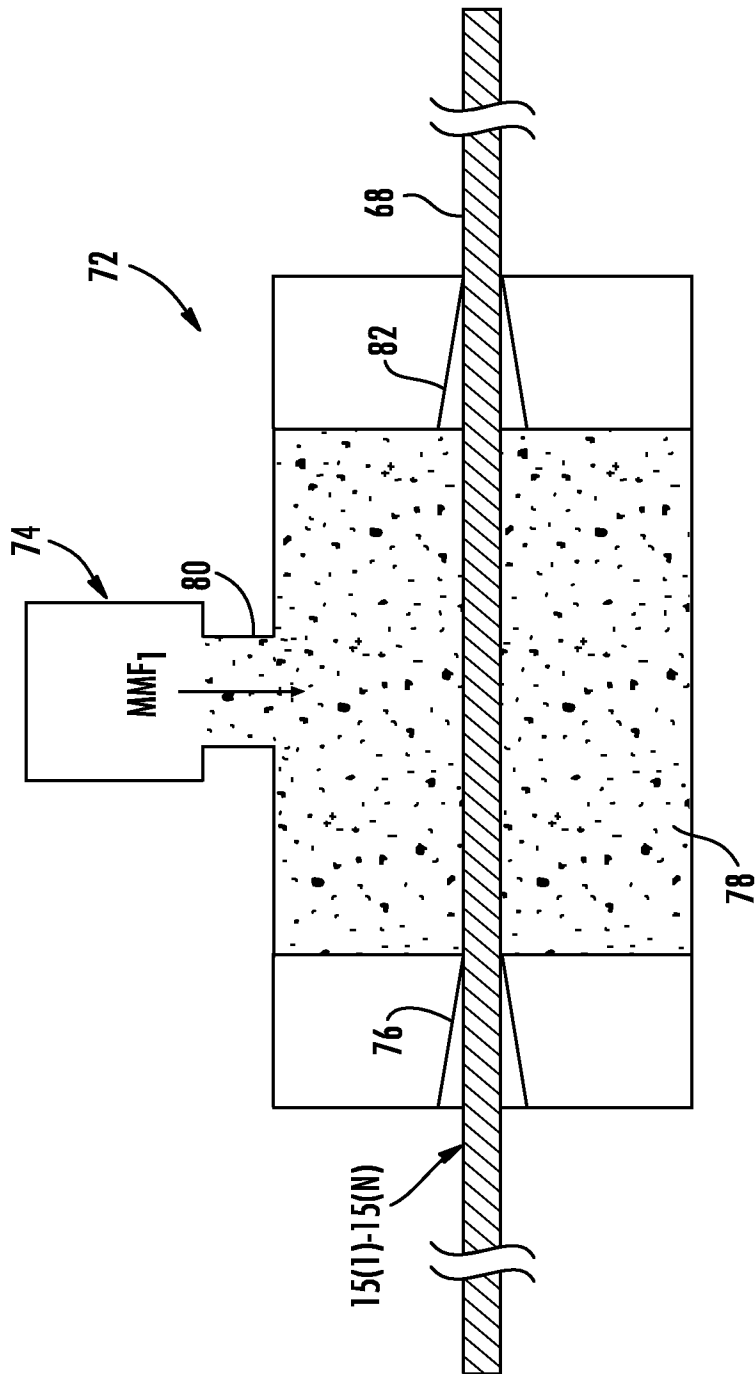

FIG. 10

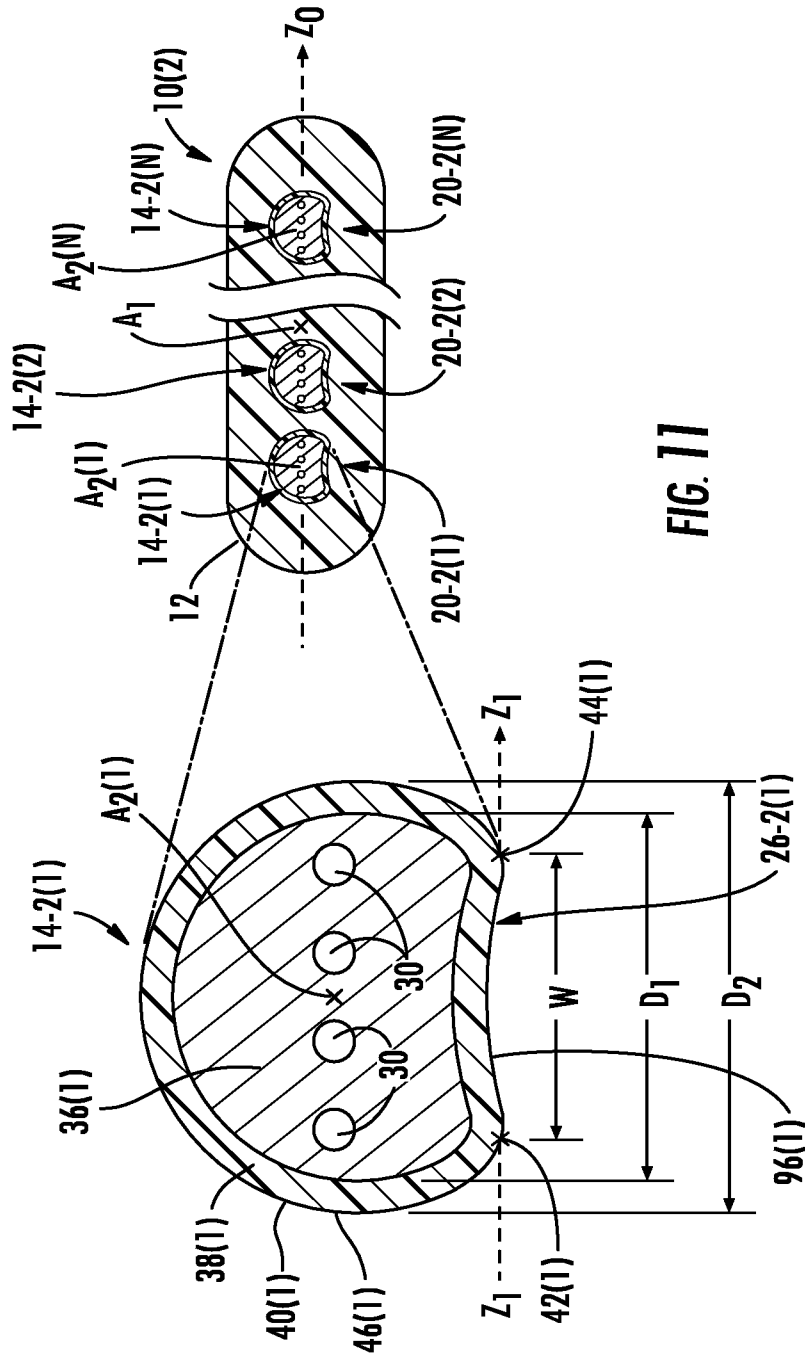

FIG. 11