

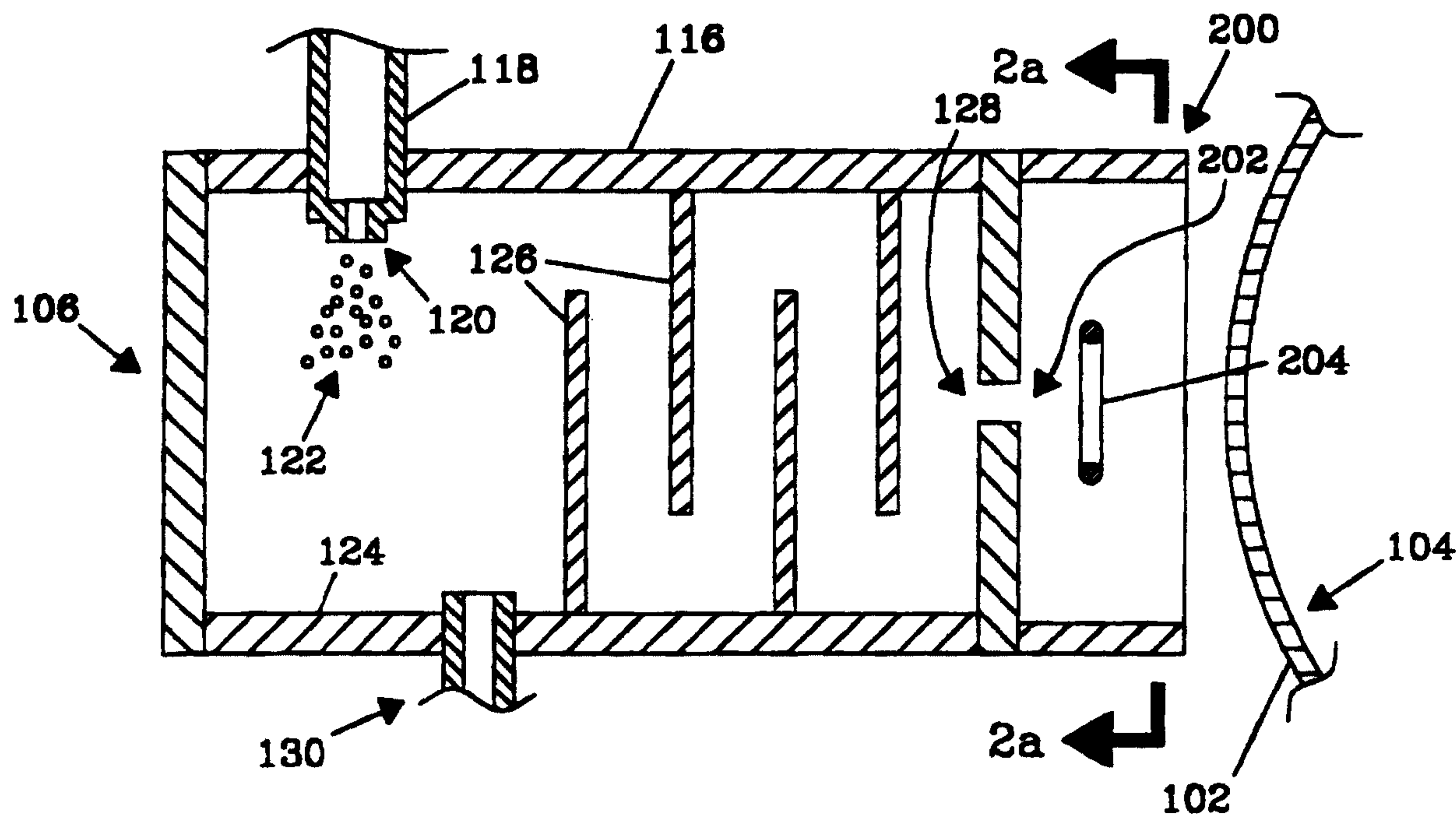

(86) Date de dépôt PCT/PCT Filing Date: 1998/09/29  
 (87) Date publication PCT/PCT Publication Date: 1999/04/08  
 (45) Date de délivrance/Issue Date: 2005/11/22  
 (85) Entrée phase nationale/National Entry: 2000/03/09  
 (86) N° demande PCT/PCT Application No.: US 1998/020742  
 (87) N° publication PCT/PCT Publication No.: 1999/016557  
 (30) Priorité/Priority: 1997/09/29 (08/939,240) US

(51) Cl.Int.<sup>7</sup>/Int.Cl.<sup>7</sup> B05D 7/24, C08K 5/3437, C08K 5/18  
 (72) Inventeurs/Inventors:  
 AFFINITO, JOHN D., US;  
 DARAB, JOHN G., US;  
 GROSS, MARK E., US  
 (73) Propriétaire/Owner:  
 BATTELLE MEMORIAL INSTITUTE, US  
 (74) Agent: FETHERSTONHAUGH & CO.

(54) Titre : EVAPORATION ECLAIR D'UN MELANGE DE PARTICULES DE MONOMERE LIQUIDE  
 (54) Title: FLASH EVAPORATION OF LIQUID MONOMER PARTICLE MIXTURE



(57) Abrégé/Abstract:

The present invention is a method of making a first solid composite polymer layer. The method has the steps of (a) mixing a liquid monomer with particles substantially insoluble in the liquid monomer forming a monomer particle mixture; (b) flash evaporating the particle mixture and forming a composite vapor, and (c) continuously cryocondensing said composite vapor on a cool substrate and cross-linking the cryocondensed film thereby forming the polymer layer.



PCT

WORLD INTELLECTUAL PROPERTY ORGANIZATION  
International Bureau

## INTERNATIONAL APPLICATION PUBLISHED UNDER THE PATENT COOPERATION TREATY (PCT)

<p>(51) International Patent Classification <sup>6</sup> : <b>B05D 7/24</b></p>	<p><b>A1</b></p>	<p>(11) International Publication Number: <b>WO 99/16557</b> (43) International Publication Date: 8 April 1999 (08.04.99)</p>
<p>(21) International Application Number: PCT/US98/20742 (22) International Filing Date: 29 September 1998 (29.09.98) (30) Priority Data: 08/939,240 29 September 1997 (29.09.97) US (71) Applicant: BATTELLE MEMORIAL INSTITUTE [US/US]; Pacific Northwest Division, Intellectual Property Services, P.O. Box 999, Richland, WA 99352 (US). (72) Inventors: AFFINITO, John, D.; 2713 Kyle Road, Kennewick, WA 99338 (US). DARAB, John, G.; 2000 Stevens, Richland, WA 99352 (US). GROSS, Mark, E.; 50 Deseret Drive, Pasco, WA 99301 (US). (74) Agent: ZIMMERMAN, Paul, W.; Battelle Memorial Institute, Pacific Northwest Division, Intellectual Property Services, P.O. Box 999, Richland, WA 99352 (US).</p>		<p>(81) Designated States: BR, CA, CN, JP, MX, European patent (AT, BE, CH, CY, DE, DK, ES, FI, FR, GB, GR, IE, IT, LU, MC, NL, PT, SE).  <b>Published</b> <i>With international search report. Before the expiration of the time limit for amending the claims and to be republished in the event of the receipt of amendments.</i></p>
<p>(54) Title: FLASH EVAPORATION OF LIQUID MONOMER PARTICLE MIXTURE</p>		
<p>(57) Abstract</p> <p>The present invention is a method of making a first solid composite polymer layer. The method has the steps of (a) mixing a liquid monomer with particles substantially insoluble in the liquid monomer forming a monomer particle mixture; (b) flash evaporating the particle mixture and forming a composite vapor; and (c) continuously cryocondensing said composite vapor on a cool substrate and cross-linking the cryocondensed film thereby forming the polymer layer.</p>		

FLASH EVAPORATION OF LIQUID MONOMER  
PARTICLE MIXTURE

5

FIELD OF THE INVENTION

The present invention relates generally to a method of making composite polymer films. More specifically, the present invention relates to making a composite polymer film from a mixture having insoluble particles (conjugated or unconjugated) in a liquid monomer. Additional layers of polymer or metal may be added under vacuum as well. As used herein, the term "(meth)acrylic" is defined as "acrylic or methacrylic". As used herein, the term "cryocondense" and forms thereof refers to the physical phenomenon of a phase change from a gas phase to a liquid phase upon the gas contacting a surface having a temperature lower than a dew point of the gas.

As used herein, the term "conjugated" refers to a chemical structure of alternating single and double bonds between carbon atoms in a carbon atom chain.

BACKGROUND OF THE INVENTION

25

The basic process of flash evaporation is described in U.S. patent 4,954,371. This basic process may also be referred to as polymer multi-layer (PML) flash evaporation. Briefly, a polymerizable and/or cross linkable material is supplied at a temperature below a decomposition temperature and polymerization temperature of the material. The material is atomized to droplets having a droplet size ranging from about 1 to about 50 microns. The droplets are then vaporized, under vacuum by contact with a heated surface above the boiling point of the material, but below the temperature which would cause pyrolysis. The vapor is

- 2 -

cryocondensed then polymerized or cross linked as a very thin polymer layer.

Many electronic devices, however, require polymer composite layers for devices including but not limited to molecularly doped polymers (MDP), light emitting polymers (LEP), and light emitting electrochemical cells (LEC). Presently these devices are made by spin coating or physical vapor deposition (PVD). Physical vapor deposition may be either evaporation or sputtering. Spin coating, surface area coverage is limited and scaling up to large surface areas requires multiple parallel units rather than a larger single unit. Moreover, physical vapor deposition processes are susceptible to pin holes.

In all of these prior art methods, the starting monomer is a (meth)acrylic monomer (FIG. 1b). When  $R_1$  is hydrogen (H), the compound is an acrylate and when  $R_1$  is a methyl group ( $CH_3$ ), the compound is a methacrylate. If the group  $R_2$  pendant to the (meth)acrylate group is fully conjugated, the O-C- linkage interrupts the conjugation and renders the monomer non-conducting. Exposure to electron beam radiation, or UV in the presence of a photoinitiator, initiates polymerization of the monomer by creating free radicals at the (C=C) double bond in the (meth)acrylate linkage. After polymerization, the two (meth)acrylate Double (C=C) bonds, where the cross-linking occurred, have been converted to single (C-C) bonds. Thus, the cross-linking step further interrupts the conjugation and makes conductivity impossible.

Therefore, there is a need for an apparatus and high deposition rate method for making composite polymer layers that may be scaled up to cover larger surface areas with a single unit and that is less susceptible to pin holes. There is also a need for a method of preserving conjugation of the monomer.

35

- 3 -

## SUMMARY OF THE INVENTION

The present invention is a method of making a first solid composite polymer layer. The method has the steps  
5 of:

(a) mixing a liquid monomer with particles substantially insoluble in the liquid monomer forming a monomer particle mixture;

(b) supplying a continuous liquid flow of  
10 said monomer particle mixture into a vacuum environment at a temperature below both the decomposition temperature and the polymerization temperature of the monomer particle mixture;

(c) continuously atomizing the monomer  
15 particle mixture into a continuous flow of droplets;

(d) continuously vaporizing the droplets by continuously contacting the droplets on a heated surface having a temperature at or above a boiling point of the liquid monomer and of the particles, but below a  
20 pyrolysis temperature, forming a composite vapor; and

(e) continuously cryocondensing said composite vapor on a cool substrate thereby forming said composite polymer layer.

Although the liquid monomer may not be conjugated  
25 because of the curing steps, the use of conjugated particles can preserve conjugation within the polymer material. If the flash evaporation is additionally combined with plasma deposition, then both the conjugated particles and the monomer may be conjugated.

30 It is, therefore, an object of the present invention to provide a method of making a composite polymer via flash evaporation.

It is further object of the present invention to provide a method of making a conjugated polymer via flash  
35 evaporation.

27714-4

- 4 -

An advantage of the present invention is that it is permits making composite layers via flash evaporation. Another advantage of the present invention is that multiple layers of materials may be combined. For  
5 example, as recited in U.S. patents 5,547,508 and 5,395,644, 5,260,095, multiple polymer layers, alternating layers of polymer and metal, and other layers may be made with the present invention in the vacuum environment.

10 The subject matter of the present invention is particularly pointed out and distinctly claimed in the concluding portion of this specification. However, both the organization and method of operation, together with further advantages and objects thereof, may best be  
15 understood by reference to the following detailed description in combination with the drawings wherein like reference characters refer to like elements.

#### BRIEF DESCRIPTION OF THE DRAWINGS

20

FIG. 1a is a cross section of a prior art combination of a glow discharge plasma generator with inorganic compounds with flash evaporation.

FIG. 1b is a drawing of a (meth)acrylic monomer.

25 FIG. 2a is a cross section of the apparatus of the present invention of combined flash evaporation and glow discharge plasma deposition.

FIG. 2b is a cross section end view of the apparatus of the present invention.

30 FIG. 3 is a cross section of the present invention wherein the substrate is the electrode.

#### DESCRIPTION OF THE PREFERRED EMBODIMENT(S)

35 According to the present invention, a first solid polymer composite layer is made by the steps of:

- 5 -

(a) mixing a liquid monomer with particles substantially insoluble in the liquid monomer forming a monomer particle mixture;

(b) flash evaporating the monomer particle mixture forming a composite vapor; and

(c) continuously cryocondensing the composite vapor on a cool substrate and cross linking a cryocondensed monomer layer thereby forming the composite polymer layer.

Flash evaporation has the steps:

(a) supplying a continuous liquid flow of said monomer particle mixture into a vacuum environment at a temperature below both the decomposition temperature and the polymerization temperature of the monomer particle mixture;

(b) continuously atomizing the monomer particle mixture into a continuous flow of droplets;

(c) continuously vaporizing the droplets by continuously contacting the droplets on a heated surface having a temperature at or above a boiling point of the liquid monomer and of the particles, but below a pyrolysis temperature, forming a composite vapor.

Insoluble is defined as not dissolving.

Substantially insoluble refers to any amount of a particle material not dissolved in the liquid monomer. Examples include solid particles that are insoluble or partially soluble in the liquid monomer, immiscible liquids that are fully or partially miscible/insoluble in the liquid monomer, and dissolvable solids that have a concentration greater than the solubility limit of the monomer so that an amount of the dissolvable solid remains undissolved.

The liquid monomer may be any liquid monomer useful in flash evaporation for making polymer films. Liquid monomer includes but is not limited to acrylic monomer,

- 6 -

for example tripropyleneglycol diacrylate, tetraethylene glycol diacrylate, tripropylene glycol monoacrylate, caprolactone acrylate and combinations thereof; methacrylic monomers; and combinations thereof. The  
5 (meth)acrylic monomers are particularly useful in making molecularly doped polymers (MDP), light emitting polymers (LEP), and light emitting electrochemical cells (LEC).

The insoluble particle may be any insoluble or partially insoluble particle type having a boiling point  
10 below a temperature of the heated surface in the flash evaporation process. For LEP/LEC devices, preferred insoluble particles are organic compounds including but not limited to N,N'-Bis(3-methylphenyl)-N,N'-  
15 diphenylbenzidine (TPD) - a hole transporting material for LEP and MDP, and Tris(8-quinolinolato) aluminumIII (Alq3) - an electron transporting and light emitting material for LEP and MDP. To achieve an LEC, it is necessary to add an electrolyte, usually a salt for  
20 example Bistrifluoromethylsulfonyl imide, Lithium-trifluoromethanesulfonate (CF<sub>3</sub>SO<sub>3</sub>Li), and combinations thereof.

The particle may be conjugated or unconjugated and the monomer may be conjugated or unconjugated. Conjugated particle or monomer include but are not  
25 limited to phenylacetylene derivatives, for example Trans-Polyphenylacetylene, polyphenylenevinylene and combinations thereof, Triphenyl Diamine Derivative, Quinacridone and combinations thereof.

The insoluble particles are preferably of a volume  
30 much less than about 5000 cubic micrometers (diameter about 21 micrometers) or equal thereto, preferably less than or equal to about 4 cubic micrometers (diameter about 2 micrometers). In a preferred embodiment, the insoluble particles are sufficiently small with respect  
35 to particle density and liquid monomer density and

27714-4

- 7 -

viscosity that the settling rate of the particles within the liquid monomer is several times greater than the amount of time to transport a portion of the particle liquid monomer mixture from a reservoir to the atomization nozzle. It is to be noted that it may be necessary to stir the particle liquid monomer mixture in the reservoir to maintain suspension of the particles and avoid settling.

The mixture of monomer and insoluble or partially soluble particles may be considered a slurry, suspension or emulsion, and the particles may be solid or liquid. The mixture may be obtained by several methods. One method is to mix insoluble particles of a specified size into the monomer. The insoluble particles of a solid of a specified size may be obtained by direct purchase or by making them by one of any standard techniques, including but not limited to milling from large particles, precipitation from solution, melting/spraying under controlled atmospheres, rapid thermal decomposition of precursors from solution as described in U.S. patent 5,652,192. The steps of U.S. patent 5,652,192 are making a solution of a soluble precursor in a solvent and flowing the solution through a reaction vessel, pressurizing and heating the flowing solution and forming substantially insoluble particles, then quenching the heated flowing solution and arresting growth of the particles. Alternatively, larger sizes of solid material may be mixed into liquid monomer then agitated, for example ultrasonically, to break the solid material into particles of sufficient size.

Liquid particles may be obtained by mixing an immiscible liquid with the monomer liquid and agitating by ultrasonic or mechanical mixing to produce liquid particles within the liquid monomer. Immiscible liquids include, for example fluorinated monomers.

- 8 -

Upon spraying, the droplets may be particles alone, particles surrounded by liquid monomer and liquid monomer alone. Since both the liquid monomer and the particles are evaporated, it is of no consequence either way. It is, however, important that the droplets be sufficiently small that they are completely vaporized. Accordingly, in a preferred embodiment, the droplet size may range from about 1 micrometer to about 50 micrometers.

10

Example 1

A first solid polymer layer was made according to the method of the present invention. Specifically, the acrylic monomer blend of 50.75 ml of tetraethyleneglycol diacrylate plus 14.5 ml tripropyleneglycolmonoacrylate plus 7.25 ml caprolactoneacrylate plus 10.15 ml acrylic acid plus 10.15 ml of EZACURE (a benzophenone blend photo initiator sold by Sartomer Corporation of Exton Pa.) was mixed with 36.25 gm of particles of solid N,N'-Bis(3-methylphenyl)-N,N'-diphenylbenzidine having a wide range of particle sizes varying from very fine to the size of grains of sand. The mixture was then agitated with a 20 kHz ultrasonic tissue mincer for about one hour to break up the solid particles to form a fine suspension. The initial mixture/suspension having about 40 vol%, or 72.5 gm, of particles was found to plug the 0.051 inch spray nozzle, so the mixture was diluted to about 20 vol%, or 36.25 gm, to avoid plugging. It will be apparent to one of skill in the art of slurry/suspension flow that increasing nozzle size may accommodate higher concentrations. The mixture was heated to about 45 °C and stirred to prevent settling. The mixture was pumped through a capillary tube of 0.08" I.D. and about 24" long to the spray nozzle of 0.051 inch which atomized (ultrasonic atomizer at 25 kHz) the mixture into droplets

27714-4

- 9 -

that fell upon a surface maintained at about 650 °F. Flash evaporation chamber walls were maintained at about 550 °F to prevent monomer cryocondensation on the flash evaporation chamber walls. The vapor cryocondensed on a polyester (PET) web maintained at a low temperature with cooling water introduced at a temperature of about 55 °F, followed by UV curing.

The cured polymer was transparent and deposited at rates of about 4 microns thick at 4 m/min. Rates of hundreds of meters/minute are achievable though.

#### Example 2

A first solid polymer layer was made according to the method of the present invention and with the parameters specified in Example 1, with the following exceptions. The solid particles were 19.5 gm (about 10.75 vol%) of Tris(8-quinolinolato)-aluminumIII consisting of a few solid chunks in excess of 0.25" across. The capillary tube was 0.032" I.D. and about 24" long to the spray nozzle.

The cured polymer was produced at a rate of about 4 microns thick at 4 m/min.

#### Example 3

An experiment was conducted as in Examples 1 and 2, but using a combination of the mixtures from Example 1 and Example 2 along with 5 gm of an electrolyte salt Bistrifluoro-methylsulfonyl imide. The cured polymer was clear and produced at a rate of about 4 microns thick at 1 m/min.

#### Alternative Embodiments

The method of the present invention may obtain a polymer layer either by radiation curing or by self curing. In radiation curing (FIG. 1a), the monomer liquid

27714-4

- 10 -

may include a photoinitiator. A flash evaporator 106 in a vacuum environment or chamber is used to deposit a monomer layer on a surface 102 of a substrate 104. In addition an e-beam gun or ultraviolet light (not shown) is provided downstream of the flash evaporation unit for cross linking or curing the cryocondensed monomer layer. A glow discharge plasma unit 100 may be used to etch the surface 102. The glow discharge plasma unit 100 has a housing 108 surrounding an electrode 112 that may be smooth or may have pointed projections 114. An inlet 110 permits entry of a gas for etching, for example oxygen or argon. In self curing, a combined flash evaporator, glow discharge plasma generator is used without either the e-beam gun or ultraviolet light.

A self curing apparatus is shown in FIG. 2a. The apparatus and method of the present invention are preferably within a low pressure (vacuum) environment or chamber. Pressures preferably range from about  $10^{-1}$  torr to  $10^{-6}$  torr. The flash evaporator 106 has a housing 116, with a monomer inlet 118 and an atomizing nozzle 120. Flow through the nozzle 120 is atomized into particles or droplets 122 which strike the heated surface 124 whereupon the particles or droplets 122 are flash evaporated into a gas, evaporate or composite vapor that flows past a series of baffles 126 to a composite vapor outlet 128 and cryocondenses on the surface 102. Cryocondensation on the baffles 126 and other internal surfaces is prevented by heating the baffles 126 and other surfaces to a temperature in excess of a cryocondensation temperature or dew point of the composite vapor. Although other gas flow distribution arrangements have been used, it has been found that the baffles 126 provide adequate gas flow distribution or uniformity while permitting ease of scaling up to large surfaces 102. The composite vapor outlet 128 directs gas

27714-4

- 11 -

toward a glow discharge electrode 204 creating a glow discharge plasma from the composite vapor. In the embodiment shown in FIG. 2a, the glow discharge electrode 204 is placed in a glow discharge housing 200 having a composite vapor inlet 202 proximate the composite vapor outlet 128. In this embodiment, the glow discharge housing 200 and the glow discharge electrode 204 are maintained at a temperature above a dew point of the composite vapor. The glow discharge plasma exits the glow discharge housing 200 and cryocondenses on the surface 102 of the substrate 104. The glow discharge monomer plasma cryocondensing on a substrate and thereon, wherein the crosslinking results from radicals created in the glow discharge plasma and achieves self curing. It is preferred that the substrate 104 is cooled. In this embodiment, the substrate 104 is moving and may be non-electrically conductive, conductive, or biased with an impressed voltage. A preferred shape of the glow discharge electrode 204 is shown in FIG. 2b. In this preferred embodiment, the glow discharge electrode 204 is shaped so that composite vapor flow from the composite vapor inlet 202 substantially flows through an electrode opening 206.

Any electrode shape can be used to create the glow discharge, however, the preferred shape of the electrode 204 does not shadow the plasma from the composite vapor, and its symmetry, relative to the monomer exit slit 202 and substrate 204, provides uniformity of the plasma across the width of the substrate while uniformity transverse to the width follows from the substrate motion.

The spacing of the electrode 204 from the substrate 104 is a gap or distance that permits the plasma to impinge upon the substrate. This distance that the plasma extends from the electrode will depend on the

27714-4

- 12 -

evaporate species, electrode 204/substrate 104 geometry, electrical voltage and frequency, and pressure in the standard way as described in detail in ELECTRICAL DISCHARGES IN GASSES, F.M. Penning, Gordon and Breach Science Publishers, 1965, and summarized in THIN FILM PROCESSES, J.L. Vossen, W. Kern, editors, Academic Press, 1978, Part II, Chapter II-1, Glow Discharge Sputter Deposition.

An apparatus suitable for batch operation is shown in FIG. 3. In this embodiment, the glow discharge electrode 204 is sufficiently proximate a part 300 (substrate) to permit the plasma to impinge upon the substrate 300. This distance that the plasma extends from the electrode will depend on the evaporate species, electrode 204/substrate 104 geometry, electrical voltage and frequency, and pressure in the standard way as described in ELECTRICAL DISCHARGES IN GASSES, F.M. Penning, Gordon and Breach Science Publishers, 1965. Thus, the part 300 is coated with the monomer condensate and self cured into a polymer layer. Sufficiently proximate may be connected to, resting upon, in direct contact with, or separated by a gap or distance. This distance that the plasma extends from the electrode will depend on the evaporate species, electrode 204/substrate 104 geometry, electrical voltage and frequency, and pressure in the standard way as described in ELECTRICAL DISCHARGES IN GASSES, F.M. Penning, Gordon and Breach Science Publishers, 1965. It is preferred, in this embodiment, that the substrate 300 be non-moving or stationary during cryocondensation. However, it may be advantageous to rotate the substrate 300 or laterally move it for controlling the thickness and uniformity of the monomer layer cryocondensed thereon. Because the cryocondensation occurs rapidly,

27714-4

- 13 -

within seconds, the part may be removed after coating and before it exceeds a coating temperature limit.

In operation, either as a method for plasma enhanced chemical vapor deposition of high molecular weight monomeric materials onto a substrate, or as  
5 a method for making self-curing polymer layers (especially polymer multi-layer (PML)), the composite polymer may be formed by cryocondensing the glow discharge composite monomer plasma on a substrate and  
10 crosslinking the glow discharge plasma thereon. The crosslinking results from radicals created in the glow discharge plasma thereby permitting self curing.

The liquid monomer may be any liquid monomer useful in flash evaporation for making polymer films. When  
15 using the apparatus of FIG. 2a to obtain self curing, it is preferred that the monomer material or liquid have a low vapor pressure, preferably less than about 10 torr at 83°F (28.3°C), more preferably less than about 1 torr at 83°F (28.3°C), and most preferably less than about 10  
20 millitorr at 83°F (28.3°C). For monomers of the same chemical family, monomers with low vapor pressures usually also have higher molecular weight and are more readily cryocondensable than lower vapor pressure, lower molecular weight monomers. Low vapor pressure monomers  
25 are more readily cryocondensable than low molecular weight monomers.

By using flash evaporation, the monomer is vaporized so quickly that reactions that generally occur from heating a liquid monomer to an evaporation  
30 temperature simply do not occur.

In addition to the evaporate from the liquid monomer, additional gases may be added through inlet 130 within the flash evaporator 106 upstream of the evaporate outlet 128, preferably between the heated surface 124 and  
35 the first baffle 126 nearest the heated surface 124.

- 14 -

Additional gases may be organic or inorganic for purposes included but not limited to ballast, reaction and combinations thereof. Ballast refers to providing sufficient molecules to keep the plasma lit in  
5 circumstances of low evaporate flow rate. Reaction refers to chemical reaction to form a compound different from the evaporate. Ballast gases include but are not limited to group VIII of the periodic table, hydrogen, oxygen, nitrogen, chlorine, bromine, polyatomic gases  
10 including for example carbon dioxide, carbon monoxide, water vapor, and combinations thereof. An exemplary reaction is by addition of oxygen gas to the monomer evaporate hexamethyldisiloxane to obtain silicon dioxide.

15

## CLOSURE

While a preferred embodiment of the present invention has been shown and described, it will be apparent to  
20 those skilled in the art that many changes and modifications may be made without departing from the invention in its broader aspects. The appended claims are therefore intended to cover all such changes and modifications as fall within the true spirit and scope of the invention.

27714-4

- 15 -

CLAIMS:

1. A method of making a solid composite polymer layer, comprising the steps of:

5 (a) mixing a liquid monomer with particles substantially insoluble in the liquid monomer forming a monomer particle mixture;

10 (b) supplying a continuous liquid flow of the monomer particle mixture into a vacuum environment at a temperature below both the decomposition temperature and the polymerization temperature of the monomer particle mixture;

(c) continuously atomizing the monomer particle mixture into a continuous flow of droplets;

15 (d) continuously vaporizing the droplets by continuously contacting the droplets on a heated surface having a temperature at or above a boiling point of the liquid monomer and of the particles, but below a pyrolysis temperature, forming a composite vapor; and

20 (e) continuously cryocondensing the composite vapor on a cool substrate and cross linking a cryocondensed monomer layer thereby forming the polymer layer.

2. The method as claimed in claim 1, wherein the liquid monomer is selected from the group consisting of (meth)acrylic monomers and a mixture thereof.

25 3. The method as claimed in claim 1 or 2, wherein the liquid monomer is an acrylic monomer selected from the group consisting of tripropyleneglycol diacrylate, tetraethylene glycol diacrylate, tripropylene glycol monoacrylate, caprolactone acrylate, and a mixture thereof.

27714-4

- 16 -

4. The method as claimed in any one of claims 1 to 3, wherein the particles are selected from the group consisting of organic solids, liquids, and a mixture thereof.

5. The method as claimed in claim 4, wherein the  
5 organic solids are selected from the group consisting of N,N'-bis(3-methylphenyl)-N,N'-diphenylbenzidine, tris(8-quinolinolato)aluminumIII, and a mixture thereof.

6. The method as claimed in any one of claims 1 to 3,  
10 wherein the particles are selected from the group consisting of phenylacetylene derivative, triphenyl diamine derivative, quinacridone and a mixture thereof.

7. The method as claimed in any one of claims 1 to 6, wherein the cross linking is radiation cross linking.

8. The method as claimed in any one of claims 1 to 6,  
15 further comprising the step of passing the composite vapor past a glow discharge electrode prior to cryocondensing, wherein the cross linking is self curing.

9. The method as claimed in any one of claims 1 to 8,  
20 further comprising adding a gas to the composite vapor upstream of a composite vapor outlet of a flash evaporator.

10. The method as claimed in claim 9, wherein the gas is a ballast gas.

11. The method as claimed in claim 9, wherein the gas is a reaction gas.

25 12. The method as claimed in claim 11, wherein the reaction gas is oxygen gas and the composite vapor includes hexamethyldisiloxane.

13. A method of making a solid composite polymer layer, comprising the steps of:

27714-4

- 17 -

(a) mixing a liquid monomer with particles substantially insoluble in the liquid monomer forming a monomer particle mixture;

(b) flash evaporating the monomer particle mixture  
5 in a vacuum environment forming a composite vapor; and

(c) continuously cryocondensing the composite vapor on a cool substrate and cross linking a cryocondensed monomer layer thereby forming the polymer layer.

14. The method as claimed in claim 13, wherein the  
10 flash evaporating comprises the steps of:

(i) supplying a continuous liquid flow of the monomer particle mixture into the vacuum environment at a temperature below both the decomposition temperature and the polymerization temperature of the monomer particle mixture;

15 (ii) continuously atomizing the monomer particle mixture into a continuous flow of droplets;

(iii) continuously vaporizing the droplets by continuously contacting the droplets on a heated surface having a temperature at or above a boiling point of the  
20 liquid monomer and of the particles, but below a pyrolysis temperature, to form the composite vapor.

15. The method as claimed in claim 13 or 14, wherein the cross linking is radiation cross linking.

16. The method as claimed in claim 13 or 14, further  
25 comprising the step of passing the composite vapor past a glow discharge electrode prior to cryocondensing, wherein the cross linking is self curing.

27714-4

- 18 -

17. The method as claimed in any one of claims 13 to 16, wherein the particles are selected from the group consisting of phenylacetylene derivative, triphenyl diamine derivative, quinacridone and a mixture thereof.

FETHERSTONHAUGH & CO.

OTTAWA, CANADA

PATENT AGENTS

1/4

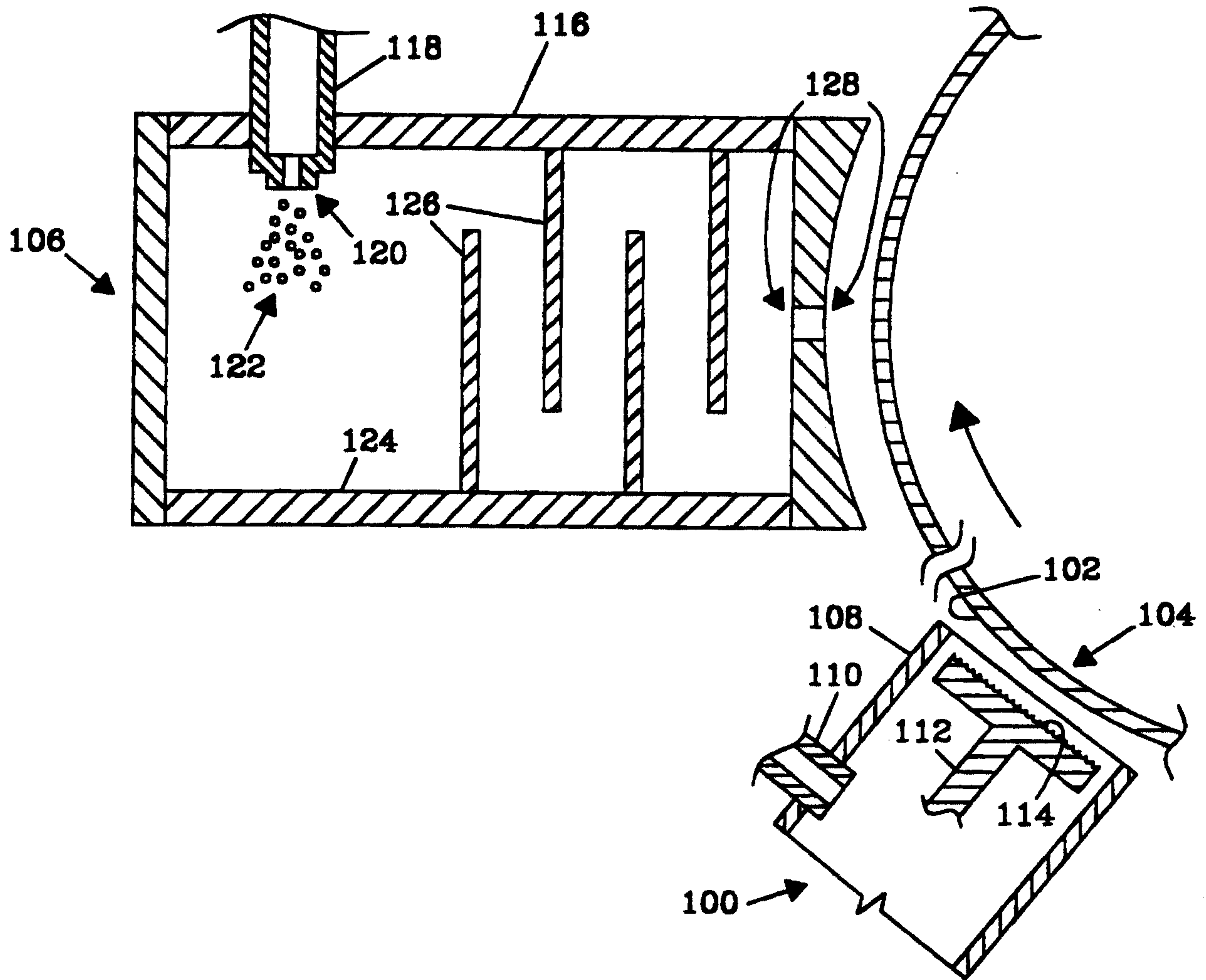

*Fig. 1a*  
*(PRIOR ART)*

2/4

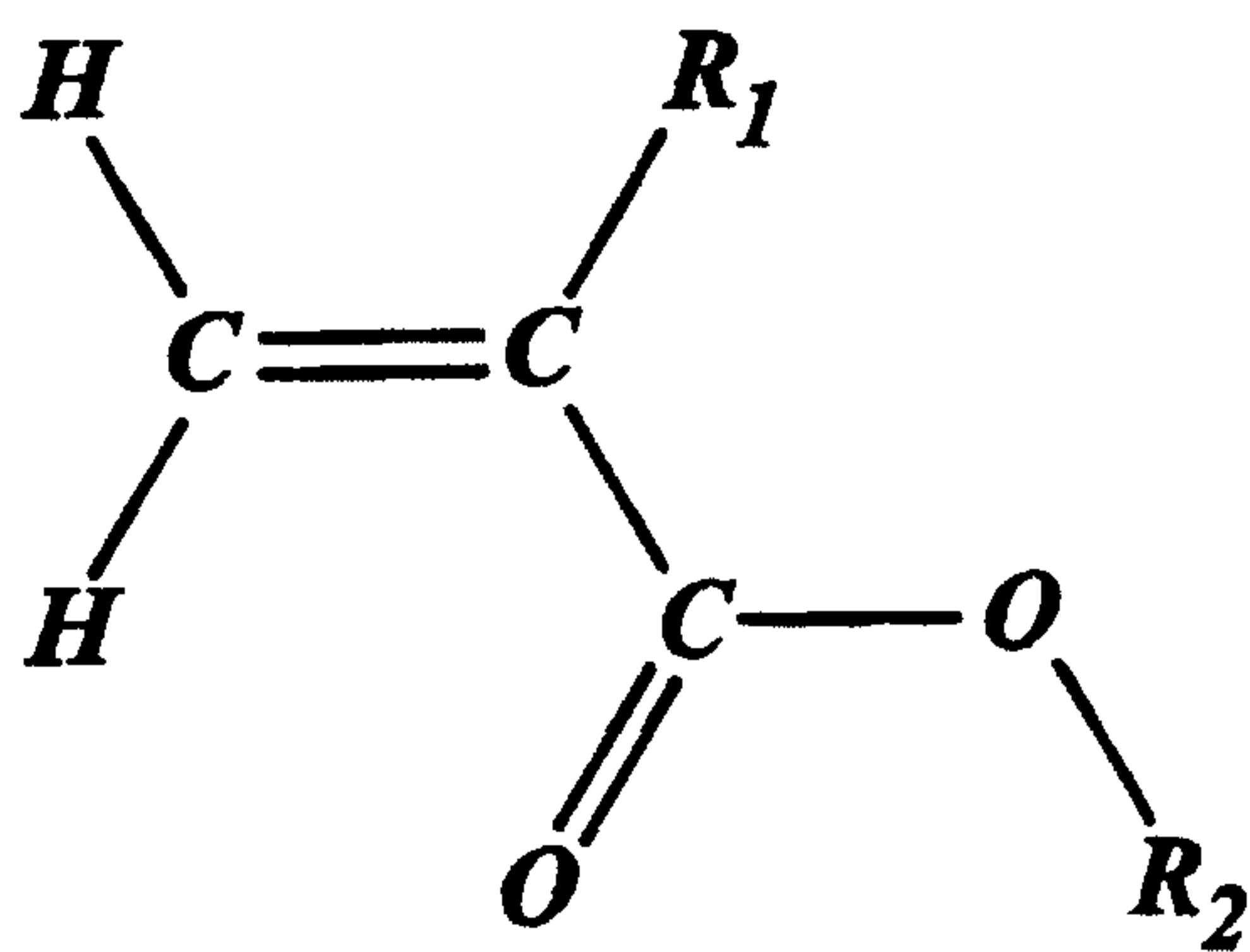

*Fig. 1b*  
*(PRIOR ART)*



4/4

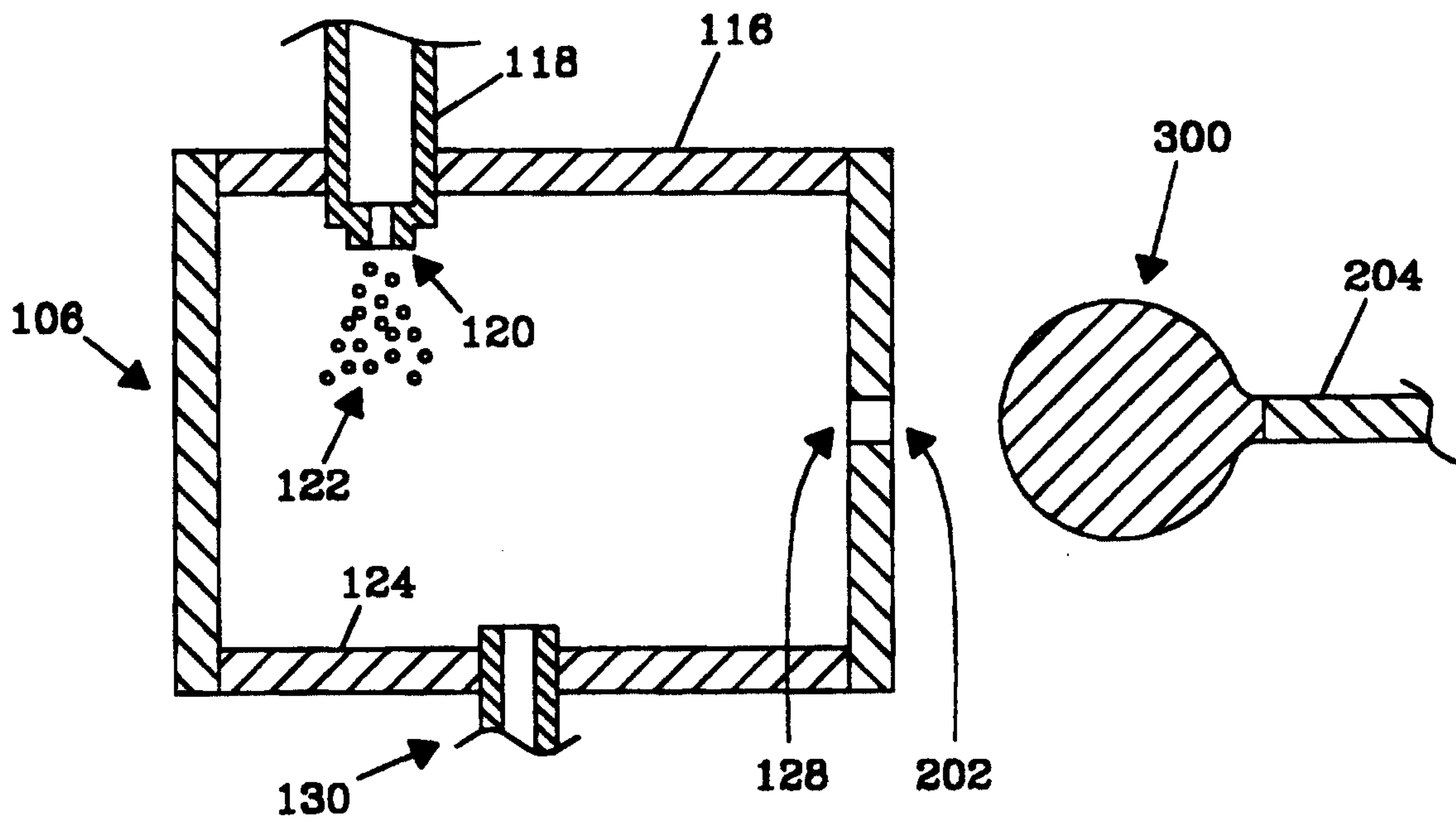

*Fig. 3*

