

J. S. BURDICK.  
 Heating Water in Vats.

No. 4,679.

Patented July 31, 1846.

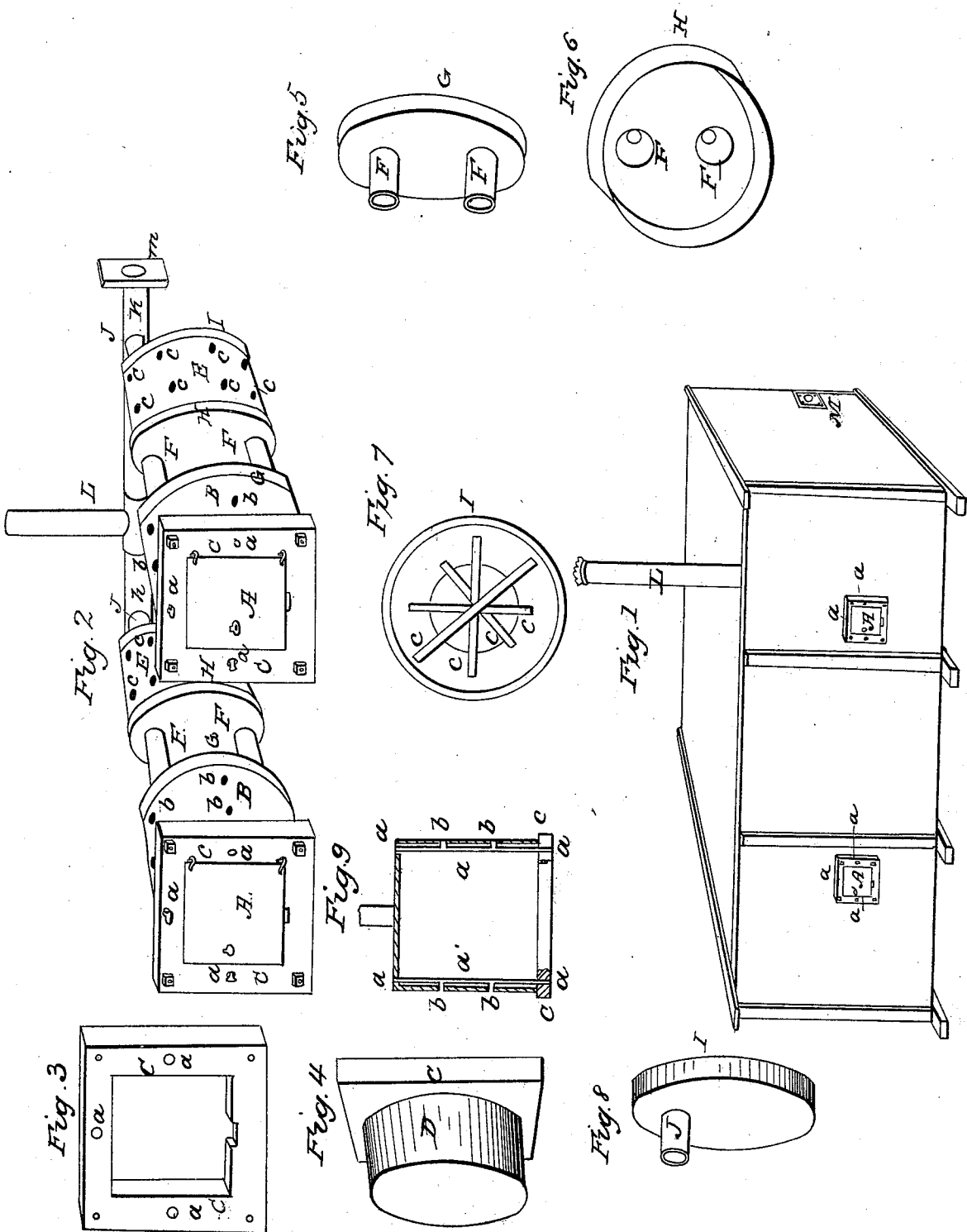

# UNITED STATES PATENT OFFICE.

JASON L. BURDICK, OF NORWICH, NEW YORK.

## HEATING WATER IN VATS.

Specification of Letters Patent No. 4,679, dated July 31, 1846.

*To all whom it may concern:*

Be it known that I, JASON L. BURDICK, of Norwich, in the county of Chenango and State of New York, have invented a new and useful apparatus for the purpose of boiling water in vats or cisterns for various purposes, but which is specially applicable to vats used by tanners for extracting the tannin from bark and to those used in the process of bleaching straw or other vegetable matters in the manufacture of paper; and I do hereby declare that the following is a full and exact description thereof.

In the accompanying drawing, Figure 1, represents a wooden vat for containing the water to be boiled, and within which I place a double furnace, the doors, or openings, into which are shown at A, A. Fig. 2, is a perspective view of the double furnace, removed from the vat, and drawn on a larger scale than said vat.

B, B, are the cylindrical bodies of the furnaces which are to contain the fuel to be burned. The openings through the wood work of the vat which receive the fore ends of these furnaces are made considerably larger than the cylindrical body of the furnace, admitting, therefore, of their being surrounded by water, and of the water being, also, in contact with the frame, C, C, of the furnace door, to which the cylinders B, B, are attached, thereby preventing the wood from being injured by the fire.

Fig. 3, is a separate view of the frame of the furnace door; Fig. 4, is a perspective view of the rear side of the same, D being a cylindrical piece cast with it, and serving to receive and secure the fore end of the furnace cylinder, B. E, E, are cylindrical water heaters, through which the draft from the furnaces passes on its way to the exit pipe; these may be of the same diameter with the furnaces, to which they are united by means of two draft tubes, F, F, extending from the rear head G, of the furnace, to the head, H, of the heater. These heads are shown separately in Figs. 5 and 6.

I, I, are the rear heads of the heaters, one of which is shown separately in Fig. 8; these are furnished with a pipe, J, that carries the draft into a horizontal pipe, K, at the back of the vat. L, is a chimney, or exit pipe, for the final escape of the smoke and heated air.

To increase the action of the heat of the furnace upon the water, I pass a number of tubes along from front to back of the furnace, which are nearly in contact with the interior of the cylinder B. *a, a, a*, on the frame, C, are openings into such tubes, which I close at their fore ends by means of screw, or other, stoppers; at their rear ends they open into the water space; to cause the water to circulate through these, I make lateral, tubular openings, *b, b*, into them through the cylinder, B, which produces the desired effect, and effectually prevents the tubes from being burned out; to which in fact they are not liable as they are not subjected, as in steam boilers, to a heavy pressure of steam. When the stoppers are removed at the fore ends of the tubes, *a*, a rod can be passed through them, and they are, therefore, readily cleaned out. This arrangement is shown in Fig. 9, which is a horizontal section through the middle of one of the furnace cylinders B; *a a'* are the tubes that extend from front to back, and that are to be closed at their fore ends *a*, and *b, b*, are the lateral tubes that admit water into the tubes *a, a*.

Through the heaters, E, E, I also pass a number of tubes, which cross from side to side of said heaters, are soldered, or otherwise fastened firmly, to them, and are open at each end, so as to allow a free passage of water through them. The openings into these tubes are shown at *c, c*; they are seen as crossing the heater in Fig. 7. These tubes may be from one to four inches in diameter, dependent on the size of the vat; they should, in fact, be of such size that water may pass readily through them.

The pipe K, K, is made to pass through the end of the vat, as seen at M, Fig. 1, where it is furnished with a stopper by which it may be perfectly closed; this allows of the removal of ashes, or other matter, which may accumulate in it. The pipes F, F, and J, may be cleaned through the furnace.

Having thus fully described the manner in which I construct my boiler, and combine it with a vat, in which water is to be boiled; what I claim therein as new and desire to secure by Letters Patent, is—

The particular arrangement and combina-

tion with the furnace, of the water heating  
tubes *a, a*, that pass through the furnaces  
B, B, these tubes having the lateral tubes  
*b b*, opening into them from the vat, by  
5 which a perpetual circulation of the water is  
obtained, and the tubes are prevented from  
being burned out.

I do not claim the combining of heating  
furnaces with vats, but I limit my claim to  
the particular device above set forth.

JASON L. BURDICK.

Witnesses:

THOS. P. JONES,  
EDWIN L. BRUNDAGE.