

(19) **DANMARK**

(10) **DK/EP 3807524 T3**



(12) **Oversættelse af
europæisk patentskrift**

Patent- og
Varemærkestyrelsen

-
- (51) Int.Cl.: **F 03 D 1/06 (2006.01)** **B 29 C 65/00 (2006.01)** **B 29 C 65/48 (2006.01)**
- (45) Oversættelsen bekendtgjort den: **2024-07-22**
- (80) Dato for Den Europæiske Patentmyndigheds bekendtgørelse om meddelelse af patentet: **2024-05-29**
- (86) Europæisk ansøgning nr.: **19769015.9**
- (86) Europæisk indleveringsdag: **2019-08-23**
- (87) Den europæiske ansøgnings publiceringsdag: **2021-04-21**
- (86) International ansøgning nr.: **EP2019072551**
- (87) Internationalt publikationsnr.: **WO2020052939**
- (30) Prioritet: **2018-09-10 EP 18193531** **2019-08-01 EP 19189605**
- (84) Designerede stater: **AL AT BE BG CH CY CZ DE DK EE ES FI FR GB GR HR HU IE IS IT LI LT LU LV MC MK MT NL NO PL PT RO RS SE SI SK SM TR**
- (73) Patenthaver: **Siemens Gamesa Renewable Energy A/S, Borupvej 16, 7330 Brande, Danmark**
- (72) Opfinder: **LOEVEN, Alex, Glentevej 44, 7400 Herning, Danmark**
Ramanujam, Giridhar, Blichersvej 25 st., 7330 Brande, Danmark
- (74) Fuldmægtig i Danmark: **Novagraaf Brevets, Bâtiment O2, 2 rue Sarah Bernhardt CS90017, F-92665 Asnières-sur-Seine cedex, Frankrig**
- (54) Benævnelse: **FREMGANGSMÅDE TIL TILVEJEBRINGELSE AF EN KANTFORSEGLING TIL ET TILFØJET ELEMENT TIL ET ROTORBLAD**
- (56) Fremdragne publikationer:
EP-A1- 3 144 525
WO-A1-2018/051153
DE-A1-102013 210 737
US-A- 4 895 491
US-A1- 2017 016 426

DESCRIPTION

Description

[0001] The invention describes a method of providing an edge seal for a rotor blade add-on.

[0002] The aerodynamic performance of wind turbine rotor blades is highly sensitive to surface imperfections, especially to those that lie in close proximity to the leading edge of the rotor blade. This presents a challenge when a step or an obstacle is present on the rotor blade surface, for example following the application of a leading edge protection (LEP) cover and/or a vortex generator (VG) panel, a trailing edge (TE) panel, etc. LEP covers are also referred to as erosion protective covers or LEP shells.

[0003] A sharp step may be present at the edges of a panel or cover attached to the rotor blade. Such an abrupt height difference causes the air flow to transition from laminar to turbulent, which will adversely impact the annual energy production (AEP) of the wind turbine and may also contribute to wind turbine noise.

[0004] It is known from the prior art to grind the edge of an already-mounted add-on into a ramp or slope in order to reduce the AEP impact. However, such a grinding procedure is time-consuming and cost-intensive. In addition, it is difficult to obtain a uniform edge along the entire edge of the add-on, and there is a risk of grinding into the rotor blade itself. The grinding procedure may also be difficult to perform, since the material of the add-on may be flexible and accordingly difficult to grind.

[0005] Another way of reducing turbulence arising from a step along the edge of an add-on is to manufacture the add-on with a thin edge. However, mounting an add-on such as a LEP cover with a long thin edge may result in wrinkling along the edge, which contributes to non-conformance cost and reduces aerodynamic performance.

[0006] In another approach, an add-on such as an LEP shell may be manufactured to fit into a built-in recess on the blade surface. However, this approach is associated with strict requirements regarding production tolerances and quality, and significantly increases manufacturing costs while also being more prone to defects.

[0007] In another approach, as proposed in EP3144525A1 and WO2018051153A1, the step at the long edge of an LEP shell is made less abrupt by applying a sealant material that tapers towards the rotor blade surface. However, the laminar airflow over edge seals has been observed to break down and to develop turbulence.

[0008] It is therefore an object of the invention to provide a way of overcoming the negative

influence of an add-on to the aerodynamic performance of a rotor blade. This object is achieved by the method of claim 1 of forming an edge seal along a longitudinal edge of an add-on part mounted on the outer surface of a rotor blade, and by the wind turbine rotor blade of claim 10

[0009] The invention describes a method of providing an edge seal along a longitudinal edge of an add-on part mounted on the outer surface of a rotor blade. The inventive method comprises the steps of determining a height at the longitudinal edge of the add-on part; determining an overlap width for the edge seal in an overlap region next to the longitudinal edge of the add-on part, wherein the ratio of overlap width to height at the longitudinal edge is in the range of 10:1 to 50:1; choosing a width for the edge seal to be applied onto the surface of the rotor blade, wherein the edge seal width is chosen to exceed the height at the longitudinal edge of the add-on part by a factor of at least twenty (i.e. the ratio of rotor blade edge seal width to add-on height is at least 20:1); and forming the edge seal over a total width comprising the overlap width and the edge seal width by applying a sealant material at least in a volume defined by the height at the longitudinal edge of the add-on part and the determined blade surface edge seal width and also in the overlap region of the add-on part to form an edge seal overlap alongside the longitudinal edge of the add-on part. The term "edge seal width" shall be understood to mean the width of the edge seal that is formed on the rotor blade surface, commencing along the longitudinal edge of the add-on part, and extending towards an outer seal edge that is generally parallel to the longitudinal edge of the add-on part. The term "overlap width" shall be understood to mean the width of the edge seal portion that extends onto the surface of the add-on. The overlap width is determined on the basis of the add-on height.

[0010] The invention is based on the insight that the laminar nature of the airflow over the rotor blade surface can be preserved by forming the edge seal over the longitudinal edge of the add-on, i.e. by having the edge seal "overlap" the outer surfaces of both the add-on and the rotor blade.

[0011] In the context of the invention, the longitudinal edge at the add-on part may be assumed to have the appearance of an abrupt step. There is no need to manufacture the add-on to have a progressively thinner longitudinal edge when it is to be mounted to a rotor blade using the inventive method, so that manufacture of such add-ons can be favourably economical. Since the add-on part is generally attached or bonded to the rotor blade in some way, for example by an adhesive bonding layer, the height at the longitudinal edge of the add-on part may be assumed to comprise the height of the add-on at that longitudinal edge, as well as the height of any adhesive layer for bonding the add-on to the rotor blade.

[0012] The edge seal width may be understood to extend outward from the longitudinal edge of the add-on. Since the edge seal width is significantly larger than the add-on height, the improved edge seal favorably reduces or even eliminates AEP losses associated with the add-on. The edge seal obtained by the inventive method also significantly reduces noise generated by the rotor blade when turning, compared to a rotor blade not provided with such edge

sealing along a part such as an LEP cover. This is primarily because the seal width obtained using the inventive method is significantly wider than any known type of edge seal. For example, it is known to apply a sealant along the edge of an add-on part or to a leading-edge protection tape, to a width of a few millimetres, but the laminar airflow over such narrow edge seals has been observed to break down and to develop turbulence.

[0013] The inventive method may be used during manufacturing of a wind turbine rotor blade and also when repairing or upgrading an already installed rotor blade. The inventive method is equally applicable to existing blade add-ons, for which the contribution to AEP will improve when provided with the inventive edge sealing.

[0014] According to the invention, the wind turbine rotor blade comprises at least one add-on part mounted to the outer surface of the rotor blade, and such an "extended" edge seal, as described above, formed along at least one longitudinal edge of the add-on part.

[0015] Particularly advantageous embodiments and features of the invention are given by the dependent claims, as revealed in the following description. Features of different claim categories may be combined as appropriate to give further embodiments not described herein.

[0016] In the following, without restricting the invention in any way, the term "add-on" may be understood to mean any of a protective cover, a plate or panel attached to the surface of the blade, especially along the longitudinal extension of the blade. The terms "edge sealing" and "edge seal" may be used interchangeably.

[0017] A sealing agent or an adhesive is used to form the edge seal along one or more edges of the add-on, as will be explained in the following. The terms "sealant material", "edge sealer" and "sealing agent" may be used to refer to such an adhesive. Preferably, the seal is formed using a liquid sealant that solidifies some time after application and which, when liquid, has a specific rheology that combines a desired sag resistance with a desired flowability. Preferably, the solidified sealant is flexible, abrasion-resistant, and adheres well to the surface to which it is applied. The sealant may be a hot-melt adhesive that becomes firm upon cooling, for example. Alternatively, a sealant that becomes firm by a chemical curing process may be preferred. Exemplary materials may be epoxy, polyurethane, polyuria, silicone, silane modified polymers (SMP), methylmethacrylate (MMA), etc., chosen in view of the desired properties of sag resistance and flowability as indicated above. For example, a sealant material may be chosen to have a specific adhesive viscosity offering a good balance between sag resistance and flowability, as well as a favorably high degree of flexibility in its cured state. The integrity of an edge seal formed along the longitudinal edges of an LEP using such a material will not suffer from repeated torsional bending of the rotor blade.

[0018] The inventive method of aerodynamically optimizing the edges of an add-on is not limited to aerodynamic devices such as LEP covers. The add-on may be a plate comprising sensors, e.g. a flexible plate that conforms to the curved surface of the rotor blade. The fixation of such a sensor plate to the rotor blade surface can benefit from the sealing concept of the

present invention, achieving improvements in respect of AEP. Such a plate may be attached to the rotor blade surface at any position between the leading edge and trailing edge of the rotor blade, and may be mounted on the suction side or the pressure side of the rotor blade. Preferably, an edge seal is formed along any longitudinal edge of such a plate, using the inventive method. In this way, neither the upwind or windward edge (i.e. the edge that is closer to rotor blade leading edge) nor the downwind edge (the edge that is closer to the rotor blade trailing edge) of such a plate will adversely affect the laminar airflow over the rotor blade surface.

[0019] As an example, the edge step height of an add-on may be 0.7 mm. The edge step height of an add-on is the sum of the thickness at the outer edge of the add-on plus the thickness of any adhesive or bonding layer used to attach the add-on to the rotor blade. In this case, the minimum width of the edge sealing for this add-on is 14 mm. For an edge step height of 1.0 mm, the minimum width of the edge sealing is 20 mm.

[0020] The ratio of edge seal width to step height can vary between 20:1 to 100:1. For the example edge step height range of 0.5 mm - 1.5 mm, the edge seal would be at least 10 mm wide, and up to 150 mm wide. Such relatively wide edge seals for rotor blade add-on parts have been observed (in wind tunnel tests) to result in an improved aerodynamic behavior.

[0021] The step of forming the edge seal comprises applying the sealant material also onto an overlap region of the add-on part. The overlap of the edge seal can advantageously form a smooth layer over the edge of the add-on.

[0022] In the inventive method, the edge seal width and overlap width for an edge seal are preferably "tuned" to a specific add-on in order to prevent or at least significantly delay the onset of flow transition from laminar to turbulent on the surface of the blade behind the edge of the add-on, i.e. downwind of the add-on. Preferably, the extent (i.e. width) of the edge sealing and the extent of the overlap will be governed by the height of the edge step at the longitudinal edge of the add-on.

[0023] The ratio of overlap width to step height can vary from 10:1 to 50:1. For the example edge step height of 0.5 mm, the overlap width would be 5 mm - 25 mm wide. For an edge step height of 1.5 mm, the edge seal width would be 15 - 75 mm wide. The recommended ratios described above are significantly larger than typically used by solutions known in the art. The maximum possible width or extent of an edge sealing may also be determined or limited by a curvature of the rotor blade.

[0024] The edge sealing proposed herein may be achieved by using a sealing agent or adhesive with sufficiently low viscosity, to be fluid enough to flow into any gaps and surface crevices formed during application of the add-on, and to ensure a smooth finish. However, since the viscosity of the adhesive will determine the minimum height of the edge seal along its outer boundaries, the sealant material is preferably also chosen such that a smooth transition to the blade surface is assured.

[0025] The sealant material may be applied using a tool set comprising a number of spatulas with different properties. In a preferred embodiment of the invention, the step of forming an edge seal comprises a step of depositing sealant material at least onto the surface of the rotor blade alongside the longitudinal edge of the add-on part. Then, a preliminary spatula is used to spread the sealant material in a region bounded by the longitudinal edge of the add-on part and the chosen edge seal width. The preliminary tool preferably has a flexibility and shape that facilitates the initial spreading of the sealant. In a subsequent step, a refining spatula is used to refine the shape of the sealant spread by the preliminary tool. Preferably, the refining tool has a lower hardness than the preliminary tool.

[0026] The inventive method can preferably include a step of delimiting the area of the intended edge seal using smooth, thin masking tape. One tape may extend along the outer edge of the intended edge seal, at a distance outward from the edge step. This distance is at least 20 times larger than the edge step height. The thickness of the tape is as small as possible, preferably at most 0.2 mm. The other boundary of the edge seal may be defined by the edge step. Alternatively, if an overlap is to be formed over the edge step, a second tape may be applied to the surface of the add-on, parallel to the longitudinal edge of the add-on. The sealant is then applied within these bounds. The sealant can initially be roughly deposited on the rotor blade (and add-on), for example in the form of a bead from a dispenser nozzle, or by spraying. The roughly applied sealant is then spread using a preliminary shaping tool, for example a flexible toothed spatula. This can be done by guiding the toothed spatula in the longitudinal direction of the rotor blade surface, between the edge seal bounds. After this preliminary step is complete, the tape or tapes are removed. The still-liquid sealant is then smoothed to its final shape by drawing a softer, flexible spatula over the spread sealant. This refining or smoothing step with the second tool serves to further decrease the height of the "wedge" of the edge seal between the edge step and the outer boundary of the edge seal. The second flexible spatula is preferably made of a material such as silicone to ensure a relatively low Shore hardness, for example 50 ± 10 .

[0027] For large edge steps, a filler material may be used to augment the edge seal. In such a preferred embodiment of the invention, filler material is applied along the edge of the add-on to reduce the edge step initially, i.e. to form a compact wedge or slope extending outward from the add-on edge. The sealant material is then applied over the filler. The filler material may have a higher viscosity than the sealant material to facilitate an easy build-up of the filler or bottom layer. The extent or width of the filler will be less than the blade surface edge seal width so that a uniform layer of sealant material can be applied over the filler to achieve a smooth transition to the rotor blade surface. The volume occupied by the filler material may be less than half the intended volume of the edge seal.

[0028] Advantageously, the inventive edge seal reduces the negative impact of steps or other obstacles on the aerodynamic performance of a rotor blade. By significantly reducing or even eliminating the negative influence of the abrupt edges of an add-on on the rotor blade aerodynamic performance, the inventive edge seal can ensure that an add-on is "AEP-neutral".

[0029] The inventive method also makes it possible to implement add-ons such as LEP shells, LEP covers etc., with a higher edge thickness. This in turn is associated with cost reduction, since the formation of a thin edge is a cost-driving factor in the manufacture of add-ons such as LEP covers and shells. The edge sealing method described above contributes to the aerodynamic performance improvement of the LEP solution. The inventive edge sealing indirectly enables the use of a shell with a thicker edge, and thereby contributes to the reduction of manufacturing costs and can assist in avoiding penalties such as non-conformance costs.

[0030] Other objects and features of the present invention will become apparent from the following detailed descriptions considered in conjunction with the accompanying drawings. It is to be understood, however, that the drawings are designed solely for the purposes of illustration and not as a definition of the limits of the invention.

Fig 1 shows an embodiment of an edge seal applied to the longitudinal edge of a rotor blade add-on;

Fig 2 shows an embodiment of the inventive edge seal;

Fig 3 shows a further embodiment of the inventive edge seal;

Fig 4 shows an add-on attached to a rotor blade surface as known from the prior art;

Fig 5 shows another add-on attached to a rotor blade surface as known from the prior art;

Figs 6 and 7 show templates used in the inventive method;

Fig 8 shows laminar airflow over an edge seal formed using the inventive method.

[0031] In the diagrams, like numbers refer to like objects throughout. Objects in the diagrams are not necessarily drawn to scale.

[0032] Fig 1 shows an embodiment of an edge seal S1 applied to an add-on 3, which can be any of a LEP cover, a shell, a TE cover, a VG panel, a TE panel, a sensor panel, etc. The add-on 3 is attached to the outer surface 20 of the rotor blade 2 by an adhesive bonding layer 33. For the purpose of discussion, the adhesive layer 33 may be regarded as an element of the add-on 3. The height t_1 of the add-on 3 at its edge 3E is the sum of the thickness of the add-on 3 and the thickness of the adhesive layer 33. The add-on edge 3E may be assumed to run in a longitudinal direction of the rotor blade 2. The diagram clearly shows the "step" shape at the edge 3E of the add-on 3. Using the inventive method, an edge seal S1 is formed along the add-on edge 3E. The edge seal S1 commences at a first point J1 at the add-on edge 3E and extends to a second point J2, whereby the height of the seal S1 gradually decreases from a maximum at point J1 to a minimum at point J2. The ratio $\delta_1:t_1$ is preferably at least 20:1. The volume of the edge seal S1 in this case is the cross-sectional area of the edge seal S1, i.e. (t_1

$\times \delta 1)/2$, multiplied by the length of the seal S1, e.g. the length of the longitudinal edge 3E of the add-on 3.

[0033] Fig 2 shows an embodiment of the inventive edge seal. Here, the edge seal S01 is applied to a longitudinal edge 3E of an add-on 3, in this case an LEP cover mounted about the leading edge of a rotor blade 2. In this exemplary embodiment, the edge seal S01 overlaps the longitudinal edge 3E of the add-on 3, i.e. the edge seal S01 commences at point J0 and extends to point J2. The total width $\delta 01$ of the edge seal S01 is therefore the width 50 of the overlap S_{ov} extending from point J0 to point J1, and the remaining edge seal width $\delta 1$ extending from point J1 to point J2. In this embodiment, the height of the seal S01 gradually increases from a minimum at point J0 to a maximum height $t01$ at point J1, and gradually decreases from the maximum height $t01$ at point J1 to a minimum at point J2. The height $t01$ of the seal S01 at its maximum may exceed the height $t1$ of the add-on edge 3E by up to 2.0 mm, depending on the overlap width 50 and/or on the edge seal width $\delta 1$ between point J1 and point J2. This height $t01$ is based on the controlled layer thickness of the sealant or adhesive applied using a tool such as a spatula.

[0034] Fig 3 shows a further embodiment of the inventive edge seal. Similarly to the edge seal S01 of Fig 2, the edge seal S01F in this case extends over a filler F that is first applied along the longitudinal add-on edge 3E. The filler F may be a quick-setting adhesive and/or a high-viscosity adhesive. The filler F can be applied to form a wedge with straight sides that are shorter than the height of the add-on 3. In a subsequent step, sealant material is applied over the cured or hardened filler F such that the resulting edge seal S01F overlaps the longitudinal edge 3E of the add-on 3, commencing at point J0 and extending to point J2. In this case also, the total width $\delta 01$ of the edge seal S01F is measured from point J0 to point J2. As described in Fig 2 above, the height of the seal S01F gradually increases from a minimum at point J0 to a maximum height $t01$ at point J1, and gradually decreases from the maximum at point J1 to a minimum at point J2. The filler F shown here could also be used in the embodiment of Fig 1.

[0035] Fig 4 shows an add-on 3 attached to a rotor blade surface 20 in a manner known from the prior art. The add-on 3 may be attached using an adhesive 33 as explained above. A longitudinal edge 3E of the add-on 3 forms an abrupt or distinct step, which can cause a laminar airflow A_{lam} to break up, resulting in turbulence A_{turb} downwind of the step 3E. Such turbulence A_{turb} reduces the aerodynamic performance of the rotor blade 2, and accordingly lowers the AEP of the wind turbine.

[0036] Fig 5 shows another prior art approach to securing an add-on 3 to a rotor blade surface 20. Here, the step 3E formed by the longitudinal edge 3E of the add-on 3 is made less abrupt by a seal 50 applied along the edge 3E. The width of such a prior art edge seal 50 is generally only between 2 - 5 mm. The incoming laminar airflow A_{lam} over the rotor blade 2 is not affected as severely as shown in Fig 4 above, but even the less abrupt step presented by the seal 50 is insufficient to preserve the laminar nature of the airflow, resulting in turbulence A_{turb} downwind of the seal 50, so that this approach also shows a negative effect on the aerodynamic

performance of the rotor blade 2 and a corresponding reduction in the wind turbine AEP.

[0037] Figs 6 and 7 show stages in forming an edge seal S01 using the inventive method. The sealant material S is roughly distributed along an edge 3E of the add-on 3, in this case a leading edge protector. With a preliminary tool T0, the roughly applied sealant S is spread to fill a volume between the long edge 3E of the add-on 3 and a mask tape 60. The mask tape is preferably smooth with a thickness of at most 0.2 mm. Here, the preliminary tool T0 is a flexible toothed spatula. Its flexibility is such that it can be bent in both axial directions to facilitate spreading of the sealant S. Then, using a refining tool T1, the still-soft sealant S is shaped as desired, in this case to form an overlap S_{ov} alongside the long edge 3E of the add-on 3. The mask tape 60 can be removed after this step. In a final step, the refining tool T1 is again used to further optimize the shape of the edge seal S01. This refining tool T1 is softer than the preliminary tool T0, for example with a Shore hardness of 40 - 60, so that it can be curved as desired during spreading of the sealant in order to achieve the desired edge seal profile shape.

[0038] Fig 8 shows airflow over an add-on that has been given an edge seal S1 using the inventive method. The diagram shows that the laminar nature of the airflow A_{lam} is maintained due to the smooth extended edge seal S1.

[0039] Although the present invention has been disclosed in the form of preferred embodiments and variations thereon, it will be understood that numerous additional modifications and variations could be made thereto without departing from the scope of the invention.

[0040] For the sake of clarity, it is to be understood that the use of "a" or "an" throughout this application does not exclude a plurality, and "comprising" does not exclude other steps or elements.

REFERENCES CITED IN THE DESCRIPTION

Cited references

This list of references cited by the applicant is for the reader's convenience only. It does not form part of the European patent document. Even though great care has been taken in compiling the references, errors or omissions cannot be excluded and the EPO disclaims all liability in this regard.

Patent documents cited in the description

- EP3144525A1 [0007]
- WO2018051153A1 [0007]

PATENTKRAV

1. Fremgangsmåde til tilvejebringelse af en kantforsegling (S01, S01F) langs en langsgående kant (3E) på et tilføjet element (3) monteret på et rotorblads (2) ydre overflade (20), hvilken fremgangsmåde omfatter følgende trin:
 - 5 - bestemmelse af en højde (t1) på det tilføjede elements (3) langsgående kant (3E);
 - bestemmelse af en overlapsbredde ($\delta 0$) for kantforseglingen (S01, S01F) i et overlapsområde (J0-J1) ved siden af det tilføjede elements (3) langsgående kant (3E), hvor forholdet mellem overlapsbredden ($\delta 0$) og højden (t1) på den langsgående
10 kant (3E) er i intervallet 10:1 til 50:1;
 - valg af en bredde (51) for den kantforsegling (S01, S01F), der skal påføres rotorbladsoverfladen (20), hvor kantforseglingens (S01, S01F) bredde (61) vælges, så den overstiger højden (t1) på det tilføjede elements (3) langsgående kant (3E) med en faktor på mindst tyve;
 - 15 og
 - udformning af kantforseglingen (S01, S01F) over en samlet bredde ($\delta 01$) omfattende overlapsbredden ($\delta 0$) og kantforseglingens bredde (51) ved at påføre rotorbladsoverfladen (20) et forseglingsmateriale (S) i mindst en mængde defineret af højden (t1) på det tilføjede elements (3) langsgående kant (3E) og den valgte
20 kantforseglingens bredde (51), og også i det tilføjede elements (3) overlapsområde (J0-J1), så der dannes et kantforseglingsoverlap (S_{ov}) langs det tilføjede elements (3) langsgående kant (3E).
2. Fremgangsmåde ifølge krav 1, hvor kantforseglingens bredde ($\delta 1$) er mindst 12 mm.
- 25 3. Fremgangsmåde ifølge krav 1 eller krav 2, hvor forholdet mellem kantforseglingens bredde ($\delta 1$) og højden (t1) på det tilføjede elements (3) langsgående kant (3E) er højst 100:1.

4. Fremgangsmåde ifølge et hvilket som helst af de foregående krav, hvor forseglingsmaterialet påføres i overlapsbredden (δ_0) og kantforseglingens bredden (51) på en sådan måde, at kantforseglingens (S01, S01F) højde (t01) overstiger det tilføjede elements (3) højde (t1) på den langsgående kant (3E).
5. Fremgangsmåde ifølge et hvilket som helst af de foregående krav, hvor trinnet bestående i udformning af kantforseglingen (S01F) forudgås af et trin bestående i påføring af et tilslagsmateriale (F) langs det tilføjede elements (3) langsgående kant (3E), hvor det volumen, der optages af tilslagsmaterialet (F), er mindre end det volumen, der er bestemt til kantforseglingen (S01F).
6. Fremgangsmåde ifølge et hvilket som helst af de foregående krav, hvor forseglingsmaterialet påføres ved hjælp af en skabelon (4), der er formet på en sådan måde, at den definerer den ønskede glatte overgang fra det tilføjede elements (3) kant (3E) til rotorbladsoverfladen (20).
7. Fremgangsmåde ifølge det foregående krav, hvor skabelonen (4) er formet på en sådan måde, at forseglingsmaterialet også fordeles i det tilføjede elements (3) overlapsområde (J0-J1).
8. Fremgangsmåde ifølge et hvilket som helst af de foregående krav, hvor kantforseglingens bredden (51) yderligere bestemmes af rotorbladets (2) krumning.
9. Fremgangsmåde ifølge et hvilket som helst af de foregående krav, hvor trinnet bestående i udformning af kantforseglingen (S01, S01F) omfatter
- påføring af forseglingsmateriale (S) i det mindste på rotorbladets (2) overflade langs det tilføjede elements (3) langsgående kant (3E);
 - anvendelse af et forberedende værktøj (T0) til at sprede forseglingsmaterialet (S) i et område afgrænset af det tilføjede elements (3) langsgående kant (3E) og den valgte kantforseglingens bredde (δ_1);
 - anvendelse af et korrigeringsværktøj (T1) til at korrigere formen af det forseglingsmateriale (S), der spredes af det forberedende værktøj (T0), hvilket korrigeringsværktøj (T1) har en mindre hårdhed end det forberedende værktøj (T0) og en profil baseret på en ønsket kantforseglingens form.

10. Vindmøllerrotorblad (2) omfattende mindst et tilføjet element (3) monteret på rotorbladets (2) ydre overflade (20) og en kantforsegling (S01, S01F) udformet ved hjælp af fremgangsmåden ifølge et hvilket som helst af krav 1 til 9 langs mindst en langsgående kant (3E) af det tilføjede element (3).
- 5 11. Vindmøllerrotorblad ifølge krav 10, hvor et tilføjet element (3) omfatter et hvilket som helst af en forkantsbeskyttelse, et bagkantspanel, et hvirvelgeneratorpanel, en plade eller et sensorpanel.
12. Vindmøllerrotorblad ifølge krav 10 eller krav 11, hvor det tilføjede elements (3) tykkelse på dets langsgående kant (3E) er i intervallet 0,5-1,5 mm.

DRAWINGS

Drawing

FIG 1

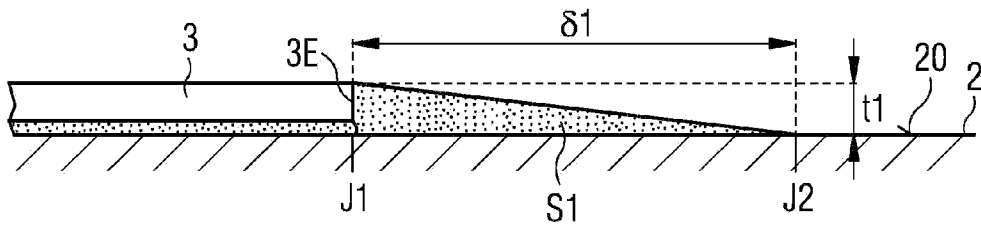

FIG 2

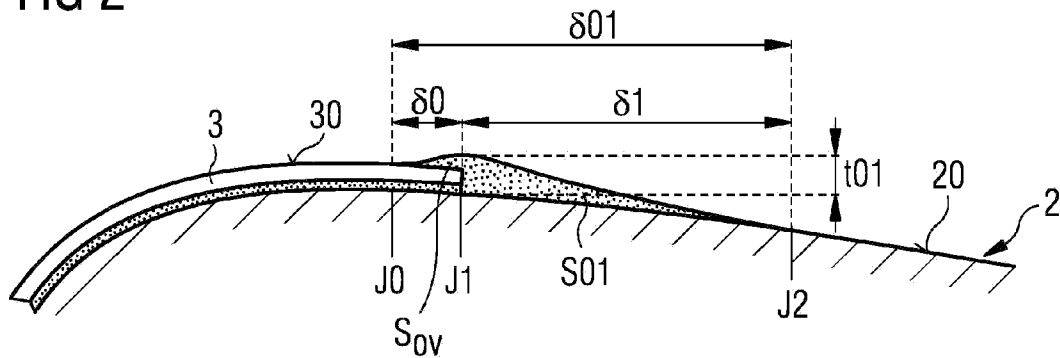

FIG 3

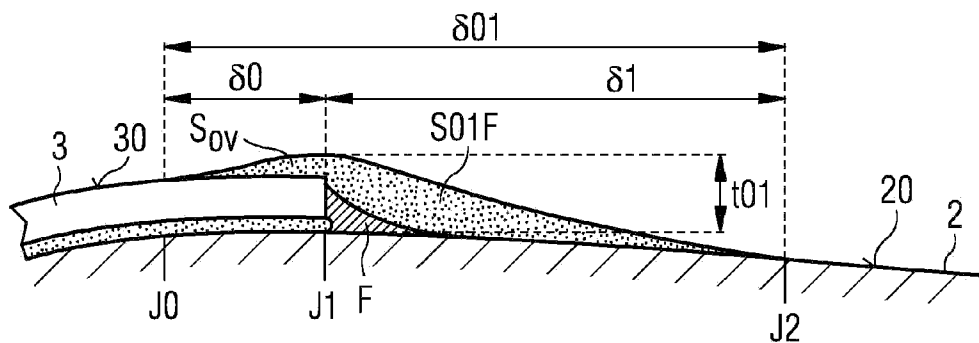

FIG 4 PRIOR ART

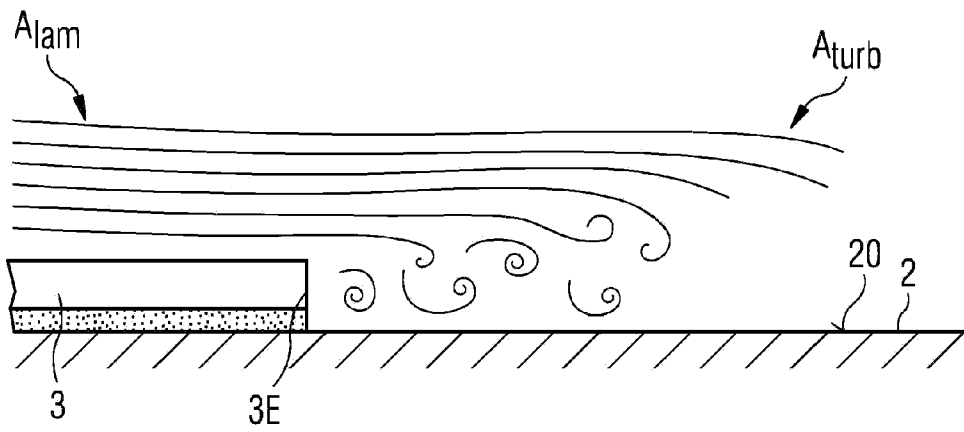

FIG 5 PRIOR ART

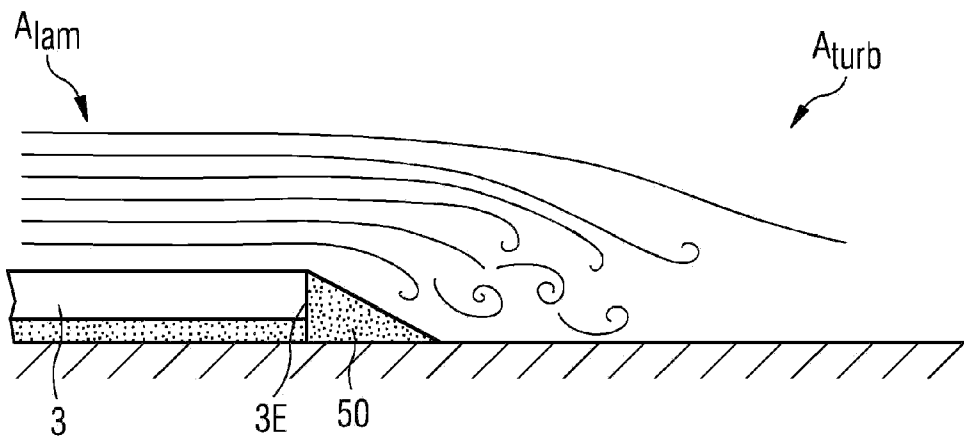

FIG 6

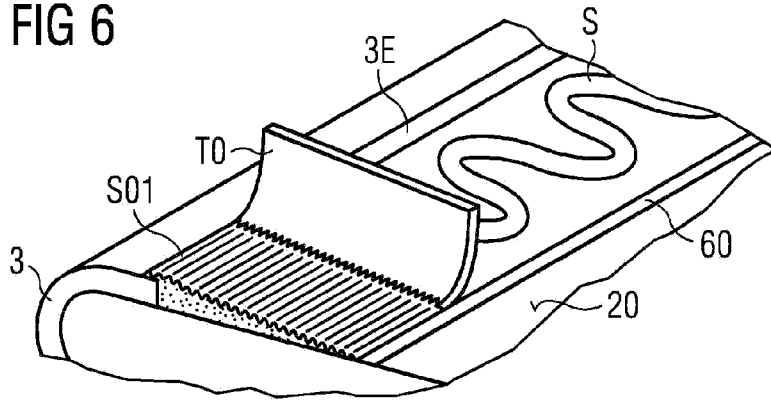

FIG 7

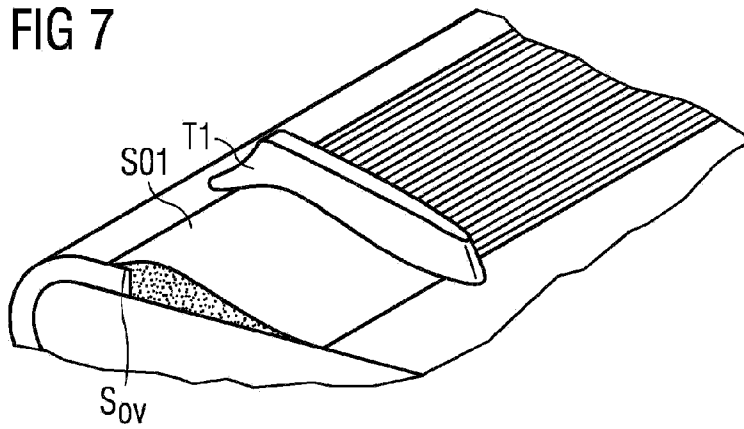

FIG 8

