

(19)



Europäisches Patentamt  
European Patent Office  
Office européen des brevets



(11)

**EP 0 399 500 B1**

(12)

**EUROPEAN PATENT SPECIFICATION**

(45) Date of publication and mention  
of the grant of the patent:  
**02.09.1998 Bulletin 1998/36**

(51) Int Cl.<sup>6</sup>: **G03G 15/16**

(21) Application number: **90109811.1**

(22) Date of filing: **23.05.1990**

(54) **Image forming apparatus**

Bilderzeugungsgerät

Appareil de formation d'images

(84) Designated Contracting States:  
**DE FR GB NL**

(30) Priority: **24.05.1989 JP 60253/89 U**  
**30.06.1989 JP 77908/89 U**  
**28.08.1989 JP 222673/89**

(43) Date of publication of application:  
**28.11.1990 Bulletin 1990/48**

(73) Proprietor: **MITA INDUSTRIAL CO., LTD.**  
**Osaka 540 (JP)**

(72) Inventors:  
• **Morishita, Hiroki**  
**Nara City (JP)**  
• **Eki, Makoto**  
**Taisho-ku, Osaka (JP)**

(74) Representative:  
**Bohnenberger, Johannes, Dr. et al**  
**Meissner, Bolte & Partner**  
**Postfach 86 06 24**  
**81633 München (DE)**

(56) References cited:

**US-A- 4 579 441**                      **US-A- 4 699 499**

- **PATENT ABSTRACTS OF JAPAN vol. 8, no. 257 (P-316)(1694), 24 November 1984; & JP - A - 59126571 (CANON) 21.07.1984**
- **PATENT ABSTRACTS OF JAPAN vol. 13, no. 210 (P-872)(3558), 17 May 1989; & JP - A - 126878 (FUJI XEROX) 30.01.1989**
- **PATENT ABSTRACTS OF JAPAN vol. 7, no. 87 (P-190)(1232) 12 April 1983; & JP - A - 5814170 (FUJI XEROX) 26.01.1983**
- **PATENT ABSTRACTS OF JAPAN vol. 8, no. 137 (P-282)(1574), 26 June 1984; & JP - A - 5938770 (FUJI XEROX) 02.03.1984**
- **PATENT ABSTRACTS OF JAPAN vol. 7, no. 260 (P-237)(1405), 18 November 1983; & JP - A - 58142361 (FUJI XEROX) 24.08.1983**

**EP 0 399 500 B1**

Note: Within nine months from the publication of the mention of the grant of the European patent, any person may give notice to the European Patent Office of opposition to the European patent granted. Notice of opposition shall be filed in a written reasoned statement. It shall not be deemed to have been filed until the opposition fee has been paid. (Art. 99(1) European Patent Convention).

## Description

The present invention relates to an image forming apparatus such as an electrophotographic copying machine, a laser printer, an electrophotographic facsimile or that like, more particularly, to an image forming apparatus provided with a guiding member which is disposed on a downstream side of a transferring device in a feed direction.

The Patent Abstracts of Japan, Vol. 7, No. 87 (P-190) (1232), April 12, 1993 (JP-A-58-14170) discloses a preventing member for preventing transfer paper from entering a transfer corotron. Guiding members are fitted on a destaticizing corotron, the guiding member extending partially into the area above the transfer corotron.

The published Japanese application JP-A-1-26878 discloses an electrostatic transfer device by which an insulating member is disposed between a transfer means and a charge removal means. Guide members are provided above the charge removal means, extensions of which extend into the opening of the transferring means.

The United States Patent 4,579,441 discloses a de-tacking apparatus for use in an image forming apparatus in which destaticizing means are disposed downstream of a transfer corotron. The destaticizing means comprise guiding elements or ribs with a destaticizing brush located therebetween.

Recently, image forming apparatus are getting smaller in size for personal use. Therefore, it is difficult to provide a particular separating device such as a separating discharger for separating a receiving substrate such as a sheet material from an image bearing member after transfer. The device may be provided with a separating belt, but no image can be formed at a portion where the separating belt is positioned, so that the copy produced lacks a part of image which is not desirable. On the other hand, if the image bearing member such as a photosensitive drum gets small, the sheet material can be detached from the photosensitive drum without any particular separating devices. In other words, if the photosensitive drum has a relatively high curvature, the sheet material is detached from the photosensitive drum by virtue of its stiffness and its own weight.

However, there are many charges on a rear surface of the sheet material which is detached from the photosensitive drum of itself. As a result, a downstream part of the sheet material after being detached from the photosensitive drum forms waves in the feed direction during conveyance because of the charges on the rear surface of the sheet material. The waves are transmitted from the downstream part of the sheet material to an upstream part thereof onto which a toner image on the photosensitive drum is being transferred, which causes inferior transfer. Therefore, the charges on the rear surface on the sheet material have to be removed as soon as possible after detachment from the photosensitive drum.

However, if a conductive material is provided in close vicinity of the transferring device such as a transfer dis-charger, charges from the transfer discharger flow as an electric current through the conductive material to ground, which also causes inferior transfer due to lack of charges for transfer. Even if the conductive material is disposed so that the sheet material may come into contact with the conductive material after detachment from the photosensitive drum, the charges on the rear surface of the sheet material flow as an electric current through the conductive material rapidly, which causes crumbling of the toner image on the sheet material due to the shock.

An image forming apparatus is disclosed in Japanese Patent Laid-Open Publication No. 126571/1984. This image forming apparatus comprises a transfer discharger, an insulating member and a charge removing member which are provided in this order in a sheet feed direction. The charge removing member is provided for removing the charges on the rear surface of the sheet material, after the sheet material is detached from the photosensitive drum by virtue of its stiffness and its own weight. The insulating member is provided between the transfer discharger and the charge removing member so that the charges from the transfer discharger may not flow as an electric current to the charge removing member.

However, the conventional apparatus has a following problem. Even if the charge removing member is useful for removing the charges from the rear surface of the sheet material as described hereinabove, the insulating member is provided on the upstream side of the charge removing member, which diminishes the charge removing action of the charge removing member and delays timing or speed of the charge removing. In detail, the area on which the charge removing action is performed by the charge removing member is not limited to an outer edge of the charge removing member, but extends over the circumference. However, the insulating member disposed on the upstream side of the charge removing member cuts off the charge removing action. On the other hand, particularly, when the receiving substrate is not a plain paper but a sheet used for an Over Head Projector (OHP), said OHP sheet holds many charges, therefore the charges have to be removed safely and effectively.

Moreover, the insulating member holds many electrostatic charges which come from the transfer discharger and are generated as sheet material moves many times. The electrostatic charges on the insulating member used as a guiding member causes not only poor conveyance of the sheet material but also adhesion of toner material. The poor conveyance of the sheet material causes crumbling of toner image on the downstream part of the sheet material which is detached from the photosensitive material, and also causes inferior transfer on the upstream part of the sheet material onto which the toner image on the photosensitive drum is being

transferred, and further causes a sheet jam.

The toner-adhesion causes stains of the sheet material which is conveyed on the insulating member used as a guiding member. More particularly, if the transfer discharger is the type in which a part of an opening of the transfer discharger is covered with a part of the guiding member, the problem is more serious. That is, the guiding member covers the part of the discharger's opening in order to regulate a breadth of discharging area and to prevent a tip of the sheet material from entering the inside of the transfer discharger, but the guiding member is charged by the transfer discharger because of its insulation. The guiding member covering the part of said opening is made of insulating material in order to prevent the inferior transfer due to an electric current flow. Thus, the charged guiding member attracts floating toners scattered in the neighbourhood of the photosensitive drum. Since the toner adheres to the surface of the guiding member the tip and the rear surface of the sheet becomes dirty when the sheet material is guided by the guiding member.

It is an object of the present invention to provide an image forming apparatus which is capable of charge removing as soon as the sheet material is detached from the photosensitive drum without causing inferior transfer or crumbling of the toner image on the sheet material.

It is another object of the present invention to provide an image forming apparatus which is capable of preventing the guiding member near the transfer discharger from being charged.

It is a further object of the present invention to provide an image forming apparatus which is capable of smooth conveyance of a sheet material, an envelope and that like.

According to the present invention, an image forming apparatus is provided as defined in claim 1.

Further objects and advantages of this invention will become apparent from the following detailed description of embodiments taken in conjunction with the accompanying drawings showing in

- Figure 1 a sectional view of a first embodiment of the present invention,
- Figure 2 a plane view of a transfer discharger and peripheral members of Figure 1,
- Figure 3 a sectional view taken on line III - III in Figure 2,
- Figure 4 a sectional view of a second embodiment of the guiding member of the present invention,
- Figure 5 a view explaining a state when an envelope is conveyed on the same guiding member as shown in Figure 2,

Figure 6 a plane view of a third embodiment of the present invention corresponding to Figure 2,

5 Figure 7 a sectional view taken on line VII-VII in Figure 6 and corresponding to Figure 3,

Figure 8 an enlarged perspective view of a part of the guiding member of Figure 6,

10 Figure 9 a plane view of a fourth embodiment of the invention,

15 Figure 10 an enlarged perspective view of a part of the guiding member of Figure 9 and corresponding to Figure 8,

With reference to the accompanying drawings, specific embodiments of the image forming apparatus constructed in accordance with this invention will be described in detail.

Figure 1 is a sectional view showing a schematic configuration of a first embodiment of this invention incorporated in an image forming apparatus. The image forming apparatus comprises a photosensitive drum 1 used for an image bearing member. The photosensitive drum 1 rotates in a direction shown by arrow R in Figure 1 at a constant speed. An electrostatic latent image formed on a surface of the drum 1 is developed by a developing device (not shown) and converted into a toner image. On the other hand, a sheet material used as a receiving substrate, such as a plain paper, an OHP sheet or that like, is fed as shown by arrow S in synchronism with the rotation of the photosensitive drum 1.

30 More concretely, a transfer discharger 5 used for a transferring means is disposed facing the photosensitive drum 1. On the upstream side of the transfer discharger 5 in the feed direction are disposed guiding members 2, 3 and a roller 4. The sheet material guided by the guiding members 2, 3 is fed to the surface of the photosensitive drum 1 by the roller 4 and comes into contact with the drum 1.

The transfer discharger 5 comprises a discharging wire 6 and a U-shaped case 5A which is made of an electric conductor such as iron and surrounds the wire 6. The transfer discharger 5 has an opening 5B facing the photosensitive drum 1. An upstream part of the opening 5B is covered with a discharging breadth regulating member 10 made of insulating material. A downstream part of the opening 5B is covered with an upstream portion of a guiding member 7 (a flat portion 72 in Figure 3). Both the discharging breadth regulating member 10 and the flat portion 72 of the guiding member 7 regulate the breadth of discharging area. Particularly, the discharging breadth regulating member 10 is effective to prevent disturbance of the toner image. That is, if no such member 10 is provided, image transfer may begin before the sheet material comes perfectly into

contact with the drum 1, therefore, the toner on the drum 1 may jump toward the sheet material, and the image may be distorted. The smaller the drum 1 becomes, the more remarkable this tendency becomes. On the other hand, if there is no such flat portion 72 of the guiding member 7, the sheet material may not detach from the drum 1 of itself. A good result can be obtained when the diameter of the drum 1 is 40 mm and the breadth of discharging area (the distance D1 in Figure 1) is 4 mm. Moreover, the flat portion 72 of the guiding member 7 also prevents the sheet material from entering inside of the transfer discharger 5. However, if the transfer discharger 5 is small enough in relation to the drum 1, good results may be obtained with the discharging breadth regulating member 10 or the flat portion 72 of the guiding member 7.

The toner image formed on the photosensitive drum 1 is transferred onto the sheet material by corona discharging from the wire 6. Subsequently, the sheet material onto which the toner image is transferred is detached from the photosensitive drum 1 of itself by virtue of its stiffness and its own weight. It is because the photosensitive drum 1 is small in diameter, that is, it has a relative small radius of curvature. In an experiment, the drum 1 was 40 mm in diameter and a good result was got. However, if the diameter is not more than 50 mm, the sheet material is detached from the drum 1 of itself.

On the downstream side of the transfer discharger 5 are disposed said guiding member 7, a charge removing brush 8 used for as a charge removing means, and a guiding member 9 in this order of success in the feed direction.

After the sheet material is detached from the photosensitive drum 1, it is guided by the guiding member 7 and residual charges on the rear surface of the sheet material are removed by the charge removing brush 8. Subsequently, the sheet material is guided by the guiding member 9.

Figure 2 is a plane view of the embodiment, and Figure 3 is a sectional view taken on line III-III in Figure 2.

The guiding member 7 has a hook-like shape in cross section. That is, the guiding member 7 comprises an upright portion 71 which is in contact with a downstream side surface of the case 5A, and a flat portion 72 covering a part of the opening 5B adjacent to said upright portion 71, and an upright portion 73 adjacent to said flat portion 72. The flat portion 72 and the upright portion 73 regulate the breadth of discharging area and prevent the sheet material from entering inside of the transfer discharger 5 as described hereinabove.

The guiding member 7 further comprises a plurality of ribs 74 on the upper surface of the flat portion 72 adjacent to said upright portion 73. The ribs 74 are disposed in an intersecting direction to the feed direction, with leaving spaces inbetween them. More minutely, the ribs 74 spread out like an unfolded fan. That is, the ribs 74 are disposed so that a downstream side of each rib

tends outward. The configuration is effective to prevent the sheet material from waving in an intersecting direction to the feed direction. That is, taking notice of each one of the ribs, the sheet material is supported on the rib which is provided in an intersecting direction to the feed direction, therefore the sheet material scarcely hangs down at a space between the rib and the adjacent rib, even if the sheet material is pressed down by forces such as its own weight, a force generated in relation to a convey force and so on. Moreover, the configuration is also effective in the point that the sheet material is stretched outwardly. Accordingly, the sheet waves in an intersecting direction to the feed direction are prevented. This means that inferior transfer is prevented. Downstream ends of the ribs 74 project (are curved) downstream with respect to the flat portion 72 and are close adjacent to the charge removing brush 8. Moreover, the charge removing brush 8 is disposed so that a tip of the brush 8 may be positioned lower than the upper portions of the ribs 74 as shown in Figures 1 and 3. Accordingly, no sheet jam does occur. Since the guiding member 7 has the aforementioned configuration the sheet material is guided by the upper portions of the ribs 74 used for as guide portions. Further, charge removing action of the charge removing brush 8 spreads over the spaces between the ribs 74 as shown in dot lines in Figure 3. Accordingly, the charge removing action is not limited or interfered by the guiding member 7 and charges on the rear surface of the sheet material are removed when the sheet material is being guided by and on the ribs 74. The higher the height of the ribs 74 is, the less the charge removing action is limited. It is noted that the height of the ribs 74 is a distance between the upper surface of the flat portion 72 and the upper portions (surface) of the ribs 74. Further, it is noted that the guiding member 7 is made of an insulating material and the charge removing brush 8 is made of electrically conducting material connected to ground potential. As the guiding member 7 is made of insulating material, the charges from the transfer discharger 5 do not flow as an electric current to the charge removing brush 8. Therefore, the arrangement can prevent inferior transfer caused by a lack of charges necessary for transfer. Further, the sheet material which is detached from the drum 1 comes into contact with the guiding member 7 made of the insulating material. Therefore, crumbling of the toner image on the sheet material caused by rapid electric current flow is prevented. As disclosed hereinabove, since the ribs 74 are provided the charge removing action of the charge removing brush 8 spreads over the spaces between the ribs 74 and the charges on the rear surface of the sheet material are removed when the sheet material is being guided by the ribs 74, thus the charges can be removed immediately and sufficiently. This means that waves of the sheet material caused by the residual charges on the rear surface of the sheet material can be prevented. It is noted that the sheet material does not come into contact with the charge removing

brush 8 directly when the sheet material has just been detached from the drum 1, but comes into contact with the ribs 74 in the state of being exposed by the charge removing action. Therefore, the action is faint enough not to crumble the toner image on the sheet material. From this point of view, it is preferable that the tip of the charge removing brush 8 is disposed at a position lower than the upper portions of the ribs 74 and the sheet material is out of contact with the charge removing brush 8. Further, as the flat portion 72 disposed between the drum 1 and the transfer discharger 5 is also made of insulating material, the charges from the transfer discharger 5 do not flow as an electric current through the conductive material to the ground. Accordingly, charges needed for transfer are fed to the sheet material, and do not cause inferior transfer. It is noted that, in an experiment, a good result was obtained when the length of the guiding member 7 in the feed direction (D2 in Figure 1) was 9 mm. The length D2 is substantially equal to a distance between the downstream edge of the discharging area and the position of the charge removing brush 8.

Figure 4 is a sectional view showing another embodiment of the guiding member. As shown in Figure 4, a guiding member 17 comprises a lower guiding portion 75 and an upper guiding portion 76, and each may be made of different materials. Preferably, the lower guiding portion 75 is made of insulating material such as polycarbonate or that like, and the upper guiding portion 76 is made of antistatic material. The antistatic material is made by various kinds of methods. For example, the antistatic material is (1) a high molecular substance mixing of an antistatic agent (the antistatic agent is, for example, quaternary ammonium salt disclosed in US-A-2,579,375, alkyl aryl sulfonate disclosed in US-A-2,978,440, magnesium oxide disclosed in US-A-2,758,984, or metallic compound such as zinc oxide, titanium oxide and that like disclosed in US-A-2,887,632, -2,940,941, -3,062,700), or (2) a high molecular substance to which an antistatic agent is applied (the antistatic agent is, for example, alkyl sulfonate disclosed in US-A-2,614,984, quaternary ammonium salt disclosed in US-A-2,876,127, polyhydric alcohol disclosed in US-A-2,955,960, or metallic oxide such as titanium oxide, tin oxide or that like disclosed in Japanese Patent Publication Nos. 6616/1960, 24890/1965). Preferably, antistatic material is made of resin. A good result was obtained when using "TOYORAKKU PARERU 88Z" (the Trade Name of TORAY Co., Ltd.). This antistatic material has a surface resistivity not causing inferior conveyance of the sheet material and not toners' adhering to the guiding member 17. That is, the surface resistivity is from about  $1 \times 10^8$  ohm-cm to about  $1 \times 10^{12}$  ohm-cm. Therefore, the surface resistivity is smaller than that of an ordinary insulating resin (about  $1 \times 10^{16}$  ohm-cm) and the antistatic material prevents the lower guiding portion 75 from being charged. Accordingly, the floating toners do not adhere very much to the upper guiding portion 76 and the upper guiding portion 76 does not become

so dirty by the toners. Further, it prevents the inferior conveyance of the sheet material which is accompanied with crumbling of the toner image and inferior transfer. In an experiment, a good result was obtained when using an antistatic material having a surface resistivity of from about  $1 \times 10^{11}$  ohm-cm to about  $1 \times 10^{12}$  ohm-cm in relation to charged potential of the photosensitive drum 1.

Further explaining the guiding member 17, the upper guiding portion 76 formed on the lower guiding portion 75 comprises a plurality of ribs 74 in the same way as the embodiment in Figure 3. Accordingly, when the sheet material is guided by the upper portion of the ribs 74, the tip and the rear surface of the sheet material do not become dirty. Moreover, the sheet material is conveyed smoothly. When the upper guiding portion 76 comprises the ribs 74, the area which is in contact with the sheet material is small, thus the sheet material is prevented from stains more effectively.

Figure 5 is a view explaining a state when an envelope is conveyed on the same guiding member 7 as Figure 2. The receiving substrate such as an envelope 104 has generally a flap portion 105 for sealing up by sticking it down. The flap portion 105 has not been stuck down yet when the image is formed, and it faces down during conveying, thus the flap portion 105 hangs down. Therefore, an edge 106 of the flap portion 105 may enter into one of the spaces between the ribs 74 and may come into contact with one of upright walls 74c of the ribs 74. It is noted that the upright walls 74c extend in an intersecting direction to the feed direction, and said one of the upright walls 74c guides the edge 106 of the envelope 104. As a result, the envelope 104 conveying in a direction shown as an arrow X in Figure 5 turns aside in a direction shown by arrow Y in Figure 5 and transfer slip occurs. When the situation is worse, the envelope 104 jams. The next embodiment is the improvement of the embodiment of Figure 2 and is shown in Figures 6 to 8.

Figure 6 is a plane view showing this embodiment, Figure 7 is a sectional view taken on line VII-VII in Figure 6, and Figure 8 is an enlarged perspective view showing a part of ribs 74 of a guiding member 27 of Figure 6.

The ribs 74 spread out like an unfolded fan. The ribs 74 comprises guide portions 74a provided at the upper portion thereof for guiding an envelope 104 and assisting guide portions are provided in the spaces therebetween. More minutely, each of the assisting guide portions is provided at an upstream or outside portion of each of the ribs 74 and assisting guide portions are declining portions 74b which decline from the guide portions 74a towards lowermost portions 72a of the spaces. The lowermost portions 72a of the spaces are coincident with an upper surface of said flat portion 72. In the case that the guiding member 27 has such a structure, even if the flap portion 105 of the envelope 104 enters into one of the spaces between the ribs 4 during conveying, the edge 106 of the flap portion 105 is guided

to the guide portions 74a by the declining portions 74b. Accordingly, the envelope 104 does not turn aside and does not jam. Moreover, the guiding member 27 still has spaces between the ribs 74 where said charge removing action of the charge removing brush 8 can spread over, as shown in dot lines in Figure 7. Accordingly, the charge removing action is not disturbed or limited by the guiding member 27.

Figures 9 and 10 show another embodiment of the assisting guide portions which constitute a part of a guiding member 37. This embodiment has flat tables 74d used as assisting guide portions instead of the declining portions 74b. Each of the flat tables 74d is also provided at an upstream or outside portion of each of the ribs 74 which extends in the intersecting direction to the feed direction. The flat tables 74d are a little lower than the guide portions 74a but higher than the lowermost portions 72a of the spaces. The flat tables 74d and the lowermost portions 72a of the spaces are disposed mutually. Space portions 80 are formed where the lowermost portions 72a are positioned. That is, each of the spaces between ribs 74 is divided into two parts. One of the parts which faces the charge removing brush 8 is remained as each of said space portions 80. The other of the parts which is positioned in the vicinity of the transfer discharger 5 is filled in as each of said flat tables 74d. Each side of the flat tables 74d which faces each of the space portions 80 is preferably parallel to the feed direction. Accordingly, even if an envelope 104 enters into the flat tables 74d, the envelope 104 is guided to the guide portions 74a easily. Since the guide portions 74a are a little higher than the flat tables 74d and spread out like an unfolded fan, the envelope 104 does not wave in an intersecting direction to the feed direction. Moreover, the charge removing action of the charge removing brush 8 spreads over said space portions 80 and, therefore, the charges on the rear surface of the envelope 104 can be removed effectively.

It is noted that the assisting guide portions are not necessary to provide in whole of the guiding member as disclosed in the above embodiments shown in Figures 6 and 9, but they may be provided only in the parts where the flap portions of the regular sizes' envelopes apt to hang down. Further, the guiding member in Figures 6 to 10 may be made of insulating material and antistatic material. The antistatic material is provided on said insulating material and is provided in at least a part of the guiding member which comes into contact with the envelope 104.

In the above embodiments in Figures 6 to 10, the guiding member comprising the assisting guide portions is disposed in the vicinity of the transfer discharger 5.

The guiding member is not limited to the above embodiments but otherwise various changes and modifications may be adopted.

Further, the ribs may be disposed so that a downstream side of each rib tends inward, contrary to the embodiment of Figure 2.

In the above embodiment in Figure 4, the guiding member 17 comprises the upper guiding portion 76 made of an antistatic material and the lower guiding portion 75 made of an insulating material. However, the guiding member 17 may otherwise be made of an antistatic material in only a part thereof which comes into contact with the sheet material. Further, the guiding member 17 may otherwise be made of an antistatic material in whole.

In the above embodiment, the charge removing brush 8 is used as charge removing means. However, it may otherwise be a metallic roller having a rough surface removing charges by projecting portions. Further, it may otherwise be a saw-shaped charge removing member, or it may be a needle-shaped charge removing member. These are shown in Figures 3 to 5 in Japanese Patent Laid-Open Publication No. 126571/1984.

## 20 Claims

1. A transfer type image forming apparatus comprising:

25 an image bearing member (1) having a small radius of curvature;

transferring means (5, 6) for electrostatically transferring a toner image formed on solid image bearing member (1) onto a receiving substrate (S), said substrate (S) being detached from the image bearing member (1) by virtue of its stiffness and/or its own weight, said transferring means (5, 6) comprising a discharge wire (6) disposed within a case (5A) of electrically conductive material having a U-shaped cross-section, the U-shape opens toward the image bearing member (1),

40 an insulating member (7) disposed on the downstream side of the case (5A) in the feed direction of the substrate, said insulating member (7) being provided with a plurality of ribs (74) thereon for guiding the substrate (S), the ribs (74) being disposed in an intersecting direction to the feed direction with spaces therebetween; and

45 charge removing means (8) for attracting charges from the rear surface of the substrate (S) after detachment from the image bearing member (1), wherein said charge removing means (8) are made of electrically conducting material and are disposed in close vicinity of the downstream side of said insulating member (7), whereby the charge removing action of said charge removing means (8) spreads over said spaces between the ribs (74) and whereby

charges on the rear surface of the substrate (S) are removed when the substrate (S) is being guided by the ribs (74),

wherein said insulating member (7) has a hook-like shape in cross-section, comprising

- a first upright section (71) in contact with the downstream side surface of said U-shaped case (5A),
- a flat section (72) arranged to cover a downstream portion of the opening of the U-shaped case (5A), and
- a second upright section (73) positioned at the upstream end of the flat section (72) and projecting towards the image bearing member (1),

said flat section (72) and said second upright section (73) regulating the breadth of the discharging area, and

said ribs (74) for guiding the substrate (S) are provided on the upper surface of the flat section (72) adjacent to said second upright section (73).

2. An image forming apparatus according to Claim 1, wherein that said ribs (74) spread out like an unfolded fan.
3. An image forming apparatus according to Claim 1 or 2, wherein said insulating member (7) comprises a plurality of assisting guide portions (74b, 74d) provided in at least some of said spaces for guiding the substrate (S) to upper guide portions (74a) of the ribs.
4. An image forming apparatus according to Claim 1, 2 or 3, wherein an antistatic material is provided on said insulating member (7) at least at an upper portion (74a) which contacts the substrate.
5. An image forming apparatus according to any one of Claims 1 to 4, wherein said charge removing means (8) is a brush-type charge removing means.
6. An image forming apparatus according to any one of Claims 1 to 5, wherein a tip of said charge removing means (8) is disposed at a position lower than upper portions (74a) of the ribs (74) whereby the receiving substrate is out of contact with the charge removing means (8).
7. An image forming apparatus according to any one of Claims 1 to 6, wherein said image bearing member (1) is not more than 50 mm in diameter.

8. An image forming apparatus according to Claim 3, wherein said ribs (74) decline towards lowermost portions (72) of the spaces and the declining portions (74b) constitute said assisting guide portions.

9. An image forming apparatus according to Claim 3, wherein said assisting guide portions are flat tables (74d) which are lower than said upper guide portions (74a) but higher than lowermost portions (72a) of the spaces (80), said flat tables (74d) and said lowermost portions (72a) of the spaces (80) are disposed next to one another between the ribs.

10. An image forming apparatus according to Claim 4, wherein said insulating member (7) comprises a lower guiding portion (75) made of insulating material and an upper guiding portion (76) made of antistatic material which is provided on said lower guiding portion (75).

11. An image forming apparatus according to Claim 10, wherein said upper guiding portion (76) is made of resin.

12. An image forming apparatus according to Claims 10 or 11, wherein said insulating member (7) is completely made of antistatic material.

13. An image forming apparatus according to Claim 10, 11, or 12, wherein said antistatic material has a surface resistivity of from  $1 \times 10^8$  ohm-cm to  $1 \times 10^{12}$  ohm-cm, preferably from  $1 \times 10^{11}$  ohm-cm to  $1 \times 10^{12}$  ohm-cm.

#### Patentansprüche

1. BildformungsVorrichtung des Übertragungstyps, enthaltend:

ein bildtragendes Element (1), das einen kleinen Krümmungsradius hat;

eine Übertragungseinrichtung (5, 6) zum elektrostatischen Übertragen eines Tonerbildes, das auf dem bildtragenden Element (1) geformt ist, auf ein Empfangssubstrat (S), welches Substrat (S) aufgrund seiner Steifigkeit und/oder seines eigenen Gewichts von dem bildtragenden Element (1) gelöst wird, wobei die Übertragungseinrichtung (5, 6) einen Entladungsdraht (6) enthält, der innerhalb eines Gehäuses (5A) aus elektrisch leitfähigem Material angeordnet ist, das einen U-förmigen Querschnitt hat, wobei sich die U-Form zu dem bildtragenden Element (1) hin öffnet,

ein isolierendes Element (7), das an der strom-

abwärts liegenden Seite des Gehäuses (5A) in Zuliefferrichtung des Substrats angeordnet ist, auf welchem isolierenden Element (7) eine Vielzahl von Rippen (74) vorgesehen ist, um das Substrat (S) zu führen, wobei die Rippen (74) in einer kreuzenden Richtung zu der Zuliefferrichtung mit dazwischenliegenden Abständen angeordnet sind; und

eine Ladungsentfernungseinrichtung (8) zum Anziehen von Ladungen von der Rückfläche des Substrats (S) nach dem Lösen von dem bildtragenden Element (1), wobei die Ladungsentfernungseinrichtung (8) aus elektrisch leitfähigem Material hergestellt ist und in unmittelbarer Nähe der stromabwärts gelegenen Seite des isolierenden Elements (7) angeordnet ist, wodurch sich die Ladungsentfernungswirkung der Ladungsentfernungseinrichtung (8) über die Räume zwischen den Rippen (74) ausbreitet und wodurch Ladungen auf der Rückfläche des Substrats (S) entfernt werden, wenn das Substrat (S) von den Rippen geführt wird,

wobei das isolierende Element (7) eine im Querschnitt hakenartige Form hat, enthaltend

- einen ersten aufrechten Abschnitt (71), der in Kontakt mit der stromabwärtsseitigen Oberfläche des U-förmigen Gehäuses (5A) ist,
- einen flachen Abschnitt (72), der so angeordnet ist, daß er einen stromabwärts liegenden Teil der Öffnung des U-förmigen Gehäuses (5A) abdeckt, und
- einen zweiten aufrechten Abschnitt (73), der an dem stromaufwärts liegenden Ende des flachen Abschnitts (72) positioniert ist und auf das bildtragende Element (1) zu vorragt,

wobei der flache Abschnitt (72) und der zweite aufrechte Abschnitt (73) die Breite der Entladungsfläche regulieren und

die Rippen (74) zum Führen des Substrats (S) an der oberen Oberfläche des flachen Abschnitts (72) dem zweiten aufrechten Abschnitt (73) benachbart vorgesehen sind.

2. Bildformungsvorrichtung nach Anspruch 1, bei welcher die Rippen (74) sich wie ein entfalteter Fächer ausbreiten.
3. Bildformungsvorrichtung nach Anspruch 1 oder 2, bei welcher das isolierende Element (7) eine Vielzahl von Hilfsführungsabschnitten (74b, 74d) enthält, die in mindestens einigen der Räume zum

Führen des Substrats (S) zu oberen Führungsabschnitten (74a) der Rippen vorgesehen sind.

4. Bildformungsvorrichtung nach Anspruch 1, 2 oder 3, bei welcher ein antistatisches Material auf dem isolierenden Element (7) mindestens an einem oberen Abschnitt (74a) vorgesehen ist, der mit dem Substrat in Berührung kommt.
5. Bildformungsvorrichtung nach einem der Ansprüche 1 bis 4, bei welcher die Ladungsentfernungseinrichtung (8) eine Ladungsentfernungseinrichtung des Bürstentyps ist.
6. Bildformungsvorrichtung nach einem der Ansprüche 1 bis 5, bei welcher eine Spitze der Ladungsentfernungseinrichtung (8) in einer Position angeordnet ist, die niedriger ist als die oberen Abschnitte (74a) der Rippen (74), wodurch das Empfangssubstrat außer Berührung mit der Ladungsentfernungseinrichtung (8) ist.
7. Bildformungsvorrichtung nach einem der Ansprüche 1 bis 6, bei welcher das bildtragende Element (1) einen Durchmesser von nicht mehr als 50 mm hat.
8. Bildformungsvorrichtung nach Anspruch 3, bei welcher die Rippen (74) zu den untersten Abschnitten (72) der Räume hin abwärts geneigt sind und die abwärts geneigten Abschnitte (74b) die Hilfsführungsabschnitte bilden.
9. Bildformungsvorrichtung nach Anspruch 3, bei welcher die Hilfsführungsabschnitte flache Tafeln (74d) sind, die niedriger sind als die oberen Führungsabschnitte (74a), aber höher als die untersten Abschnitte (72a) der Räume (80), wobei die flachen Tafeln (74d) und die untersten Abschnitte (72a) der Räume (80) nebeneinander zwischen den Rippen angeordnet sind.
10. Bildformungsvorrichtung nach Anspruch 4, bei welcher das isolierende Element (7) einen unteren Führungsabschnitt (75), der aus isolierendem Material hergestellt ist, und einen aus antistatischem Material hergestellten oberen Führungsabschnitt (76) enthält, der an dem unteren Führungsabschnitt (75) vorgesehen ist.
11. Bildformungsvorrichtung nach Anspruch 10, bei welcher der obere Führungsabschnitt (76) aus Harz hergestellt ist.
12. Bildformungsvorrichtung nach Anspruch 10 oder

11,  
bei welcher das isolierende Element (7) vollständig  
aus antistatischem Material hergestellt ist.

13. Bildformungsvorrichtung nach Anspruch 10, 11 5  
oder 12,  
bei welcher das antistatische Material einen spezi-  
fischen Oberflächenwiderstand von  $1 \times 10^8$  Ohm-  
cm bis  $1 \times 10^{12}$  Ohm-cm, vorzugsweise von  $1 \times 10^{11}$   
Ohm-cm bis  $1 \times 10^{12}$  Ohm-cm hat. 10

### Revendications

1. Un appareil de formation d'images du type transfert 15  
comprenant :

un organe de support d'images (1) ayant un fai-  
ble rayon de courbure, 20

des moyens de transfert (5, 6) pour transférer  
par voie électrostatique une image en toner for-  
mée sur ledit organe de support d'images (1)  
sur un substrat (S) récepteur, ledit substrat (S)  
étant séparé de l'organe de support d'images 25  
(1) du fait de sa rigidité et/ou de son poids pro-  
pre, lesdits moyens de transfert (5, 6) compre-  
nant un conducteur de décharge (6) disposé à  
l'intérieur d'un boîtier (5A) en matériau électro-  
conducteur ayant une section transversale en 30  
forme de U dans laquelle la forme de U s'ouvre  
vers l'organe de support d'images (1),

un organe isolant (7) disposé du côté aval du  
boîtier (5A) dans la direction d'amenée du 35  
substrat, ledit organe isolant (7) étant muni  
d'une pluralité de nervures (74) dessus pour  
guider le substrat (S), les nervures (74) étant  
disposées dans une direction croisant la direc-  
tion d'amenée, avec des espaces entre elles et 40

des moyens d'enlèvement de charges (8) pour  
attirer des charges depuis la surface arrière du  
substrat (S) après séparation d'avec l'organe  
de support d'images (1), lesdits moyens d'en- 45  
lèvement de charges (8) étant faits d'un maté-  
riau électro-conducteur et étant disposés au  
voisinage immédiat du côté aval dudit organe  
isolant (7), grâce à quoi l'action d'enlèvement  
de charges desdits moyens d'enlèvement de 50  
charges (8) s'étend sur lesdits espaces entre  
les nervures (74) et grâce à quoi des charges  
sur la surface arrière du substrat (S) sont enle-  
vées pendant que le substrat (S) est guidé par  
les nervures (74), 55

dans lequel ledit organe isolant (7) a une forme de  
crochet en section transversale, comprenant

- une première section verticale (71) en contact  
avec la surface du côté aval dudit boîtier (5A)  
en forme de U,

- une section plane (72) agencée pour couvrir  
une portion aval de l'ouverture du boîtier (5A)  
en forme de U, et

- une seconde section verticale (73) positionnée  
à l'extrémité amont de la section plane (72) et  
faisant saillie vers l'organe de support d'images  
(1),

ladite section plane (72) et ladite seconde sec-  
tion verticale (73) régulant la largeur de la sur-  
face de décharge et

lesdites nervures (74) pour guider le substrat  
(S) sont disposées sur la surface supérieure de  
la section plane (72) adjacentes à ladite secon-  
de section verticale (73).

2. Un appareil de formation d'images selon la reven-  
dication 1,  
dans lequel lesdites nervures (74) s'étalent comme  
un éventail déployé.

3. Un appareil de formation d'images selon la reven-  
dication 1 ou 2,  
dans lequel ledit organe isolant (7) comprend une  
pluralité de portions de guidage (74b, 74d) auxiliai-  
res disposées dans au moins certains desdits es-  
paces pour guider le substrat (S) vers des portions  
de guidage (74a) supérieures des nervures.

4. Un appareil de formation d'images selon la reven-  
dication 1, 2 ou 3,  
dans lequel un matériau antistatique est disposé  
sur ledit organe isolant (7) au moins à une portion  
supérieure (74a) qui est en contact avec le substrat.

5. Un appareil de formation d'images selon l'une quel-  
conque des revendications 1 à 4,  
dans lequel lesdits moyens d'enlèvement de char-  
ges (8) sont des moyens d'enlèvement de charges  
du type brosse.

6. Un appareil de formation d'images selon l'une quel-  
conque des revendications 1 à 5,  
dans lequel une extrémité desdits moyens d'enlè-  
vement de charges (8) est disposée à une position  
plus bas que des portions supérieures (74a) des  
nervures (74), grâce à quoi le substrat récepteur est  
hors de contact avec les moyens d'enlèvement de  
charges (8).

7. Un appareil de formation d'images selon l'une quel-  
conque des revendications 1 à 6,

dans lequel ledit organe de support d'images (1) n'a pas plus de 50 mm de diamètre.

8. Un appareil de formation d'images selon la revendication 3, 5  
 dans lequel lesdites nervures (74) sont inclinées vers des portions (72) les plus basses des espaces et les portions inclinées (74b) constituent lesdites portions de guidage auxiliaires. 10
9. Un appareil de formation d'images selon la revendication 3, 15  
 dans lequel lesdites portions de guidage auxiliaires sont des tables planes (74d) qui sont plus bas que lesdites portions de guidage supérieures (74a) mais plus haut que les portions (72a) les plus basses des espaces (80), lesdites tables planes (74d) et lesdites portions (72a) les plus basses des espaces (80) étant disposées proches les unes des autres entre les nervures. 20
10. Un appareil de formation d'images selon la revendication 4, 25  
 dans lequel ledit organe isolant (7) comprend une portion de guidage inférieure (75) faite d'un matériau isolant et une portion de guidage supérieure (76) faite d'un matériau antistatique qui est disposé sur ladite portion de guidage inférieure (75).
11. Un appareil de formation d'images selon la revendication 10, 30  
 dans lequel ladite portion de guidage supérieure (76) est faite d'une résine.
12. Un appareil de formation d'images selon la revendication 10 ou 11, 35  
 dans lequel ledit organe isolant (7) est complètement fait d'un matériau antistatique.
13. Un appareil de formation d'images selon la revendication 10, 11 ou 12, 40  
 dans lequel ledit matériau antistatique a une résistivité superficielle de  $1 \times 10^8$  ohm-cm à  $1 \times 10^{12}$  ohm-cm, de préférence de  $1 \times 10^{11}$  ohm-cm à  $1 \times 10^{12}$  ohm-cm. 45

50

55

FIG. 1

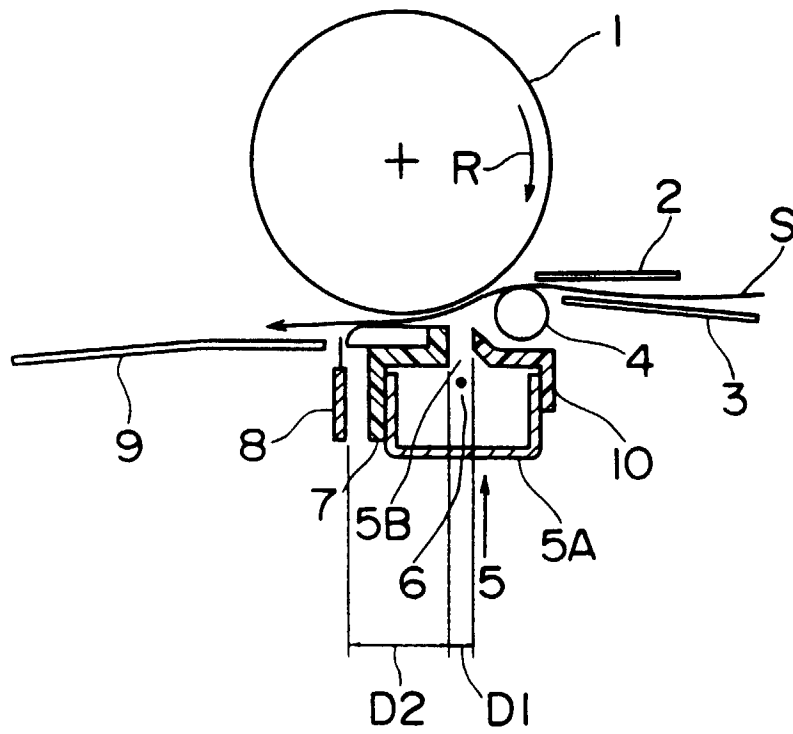

FIG. 2

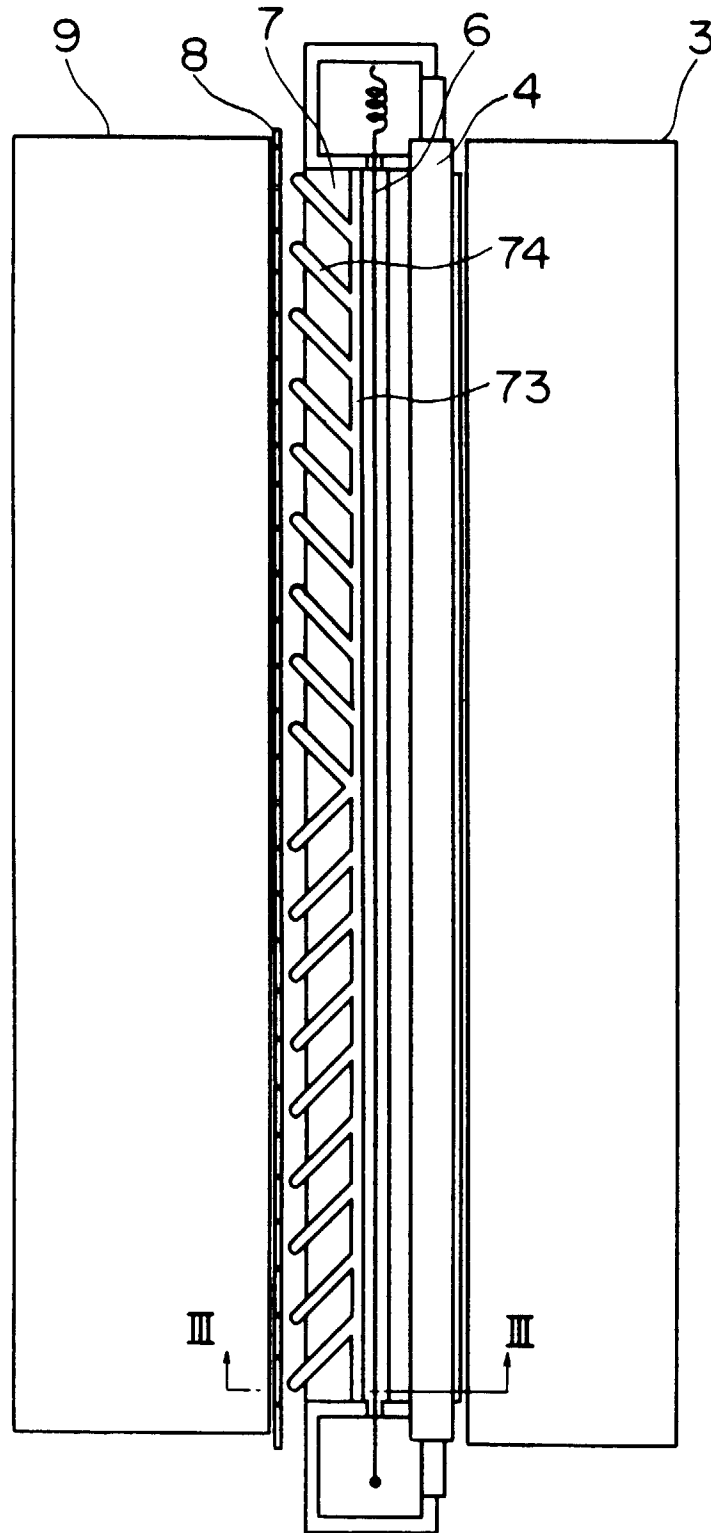

FIG. 3

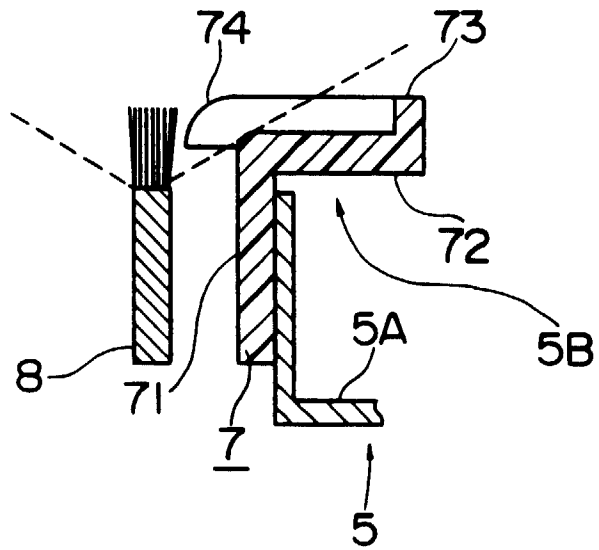

FIG. 4

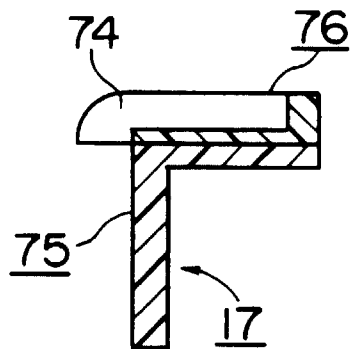

FIG. 5

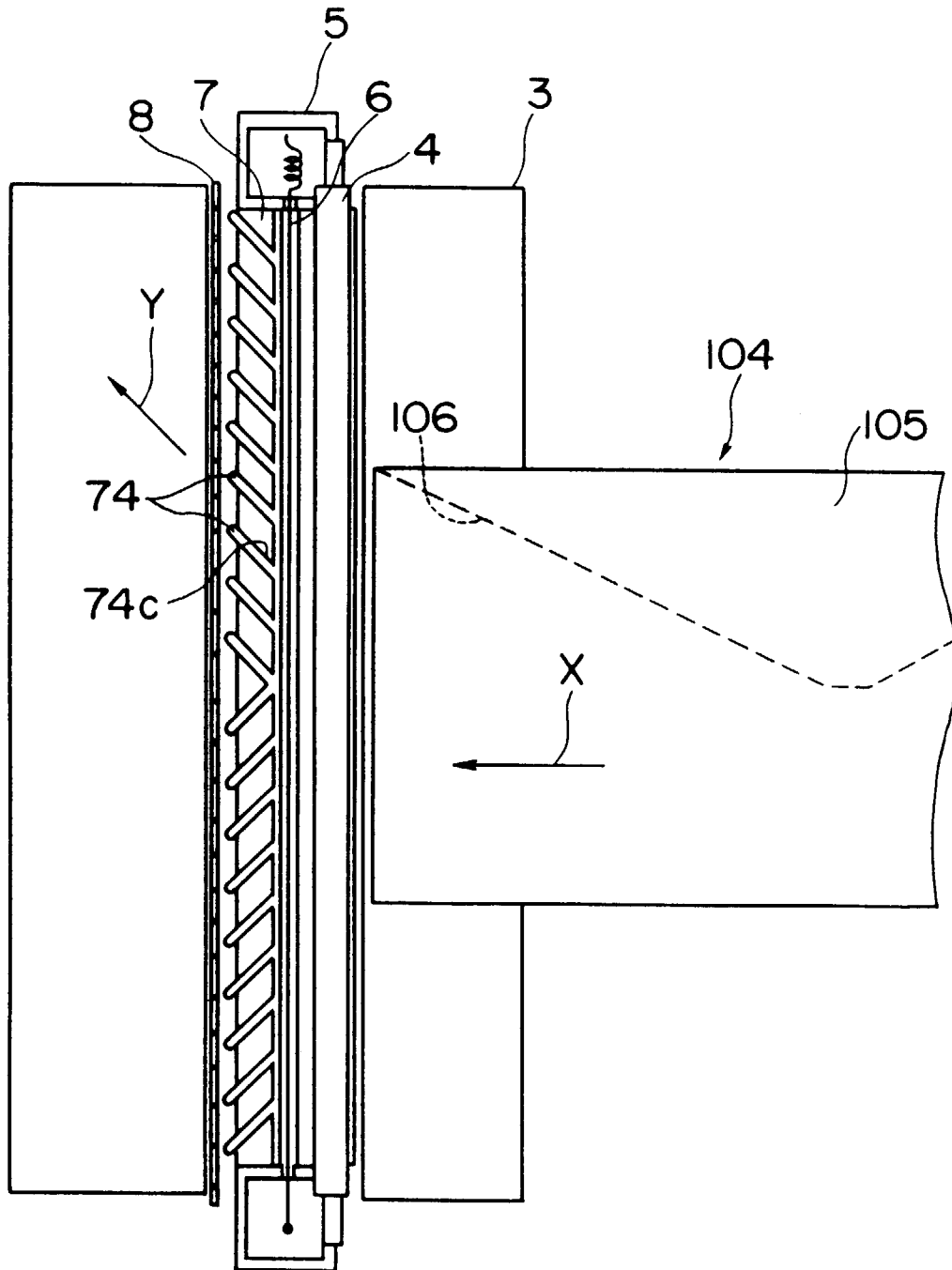

FIG. 6

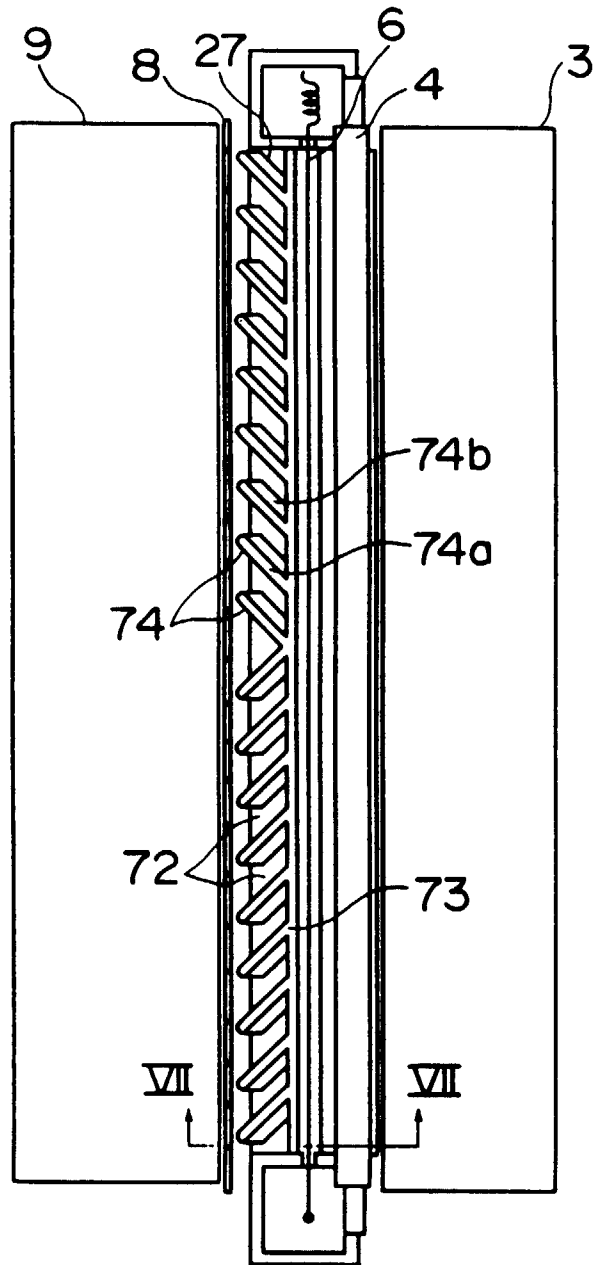

FIG. 7

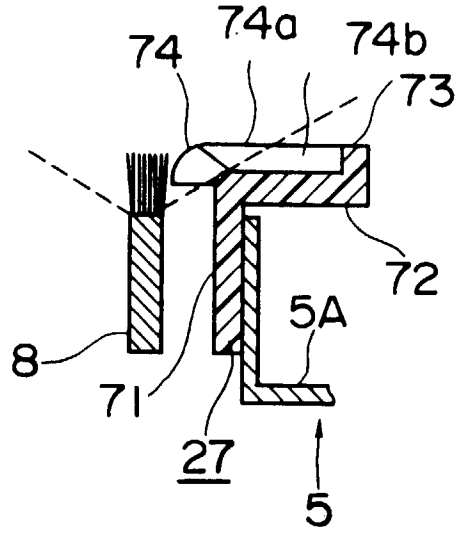

FIG. 8

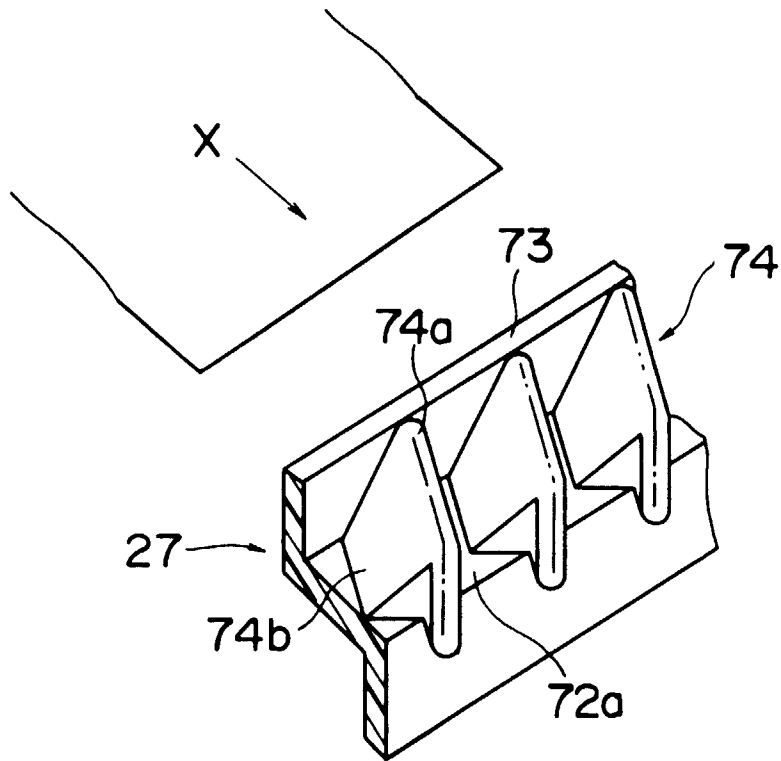

FIG. 9

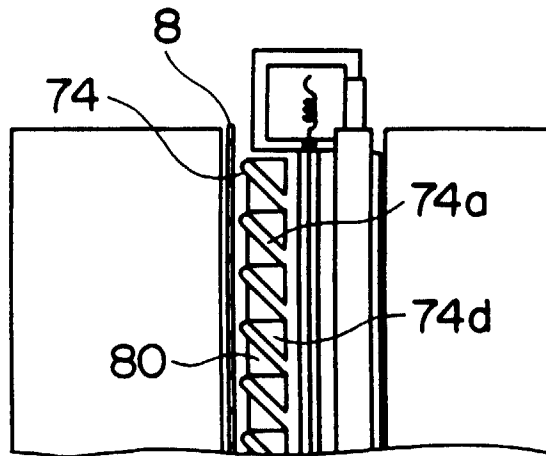

FIG. 10

