

C. A. WASHBURN.
TYPE WRITING MACHINE.

No. 109,161.

Patented Nov. 8, 1870.

Fig. 1.

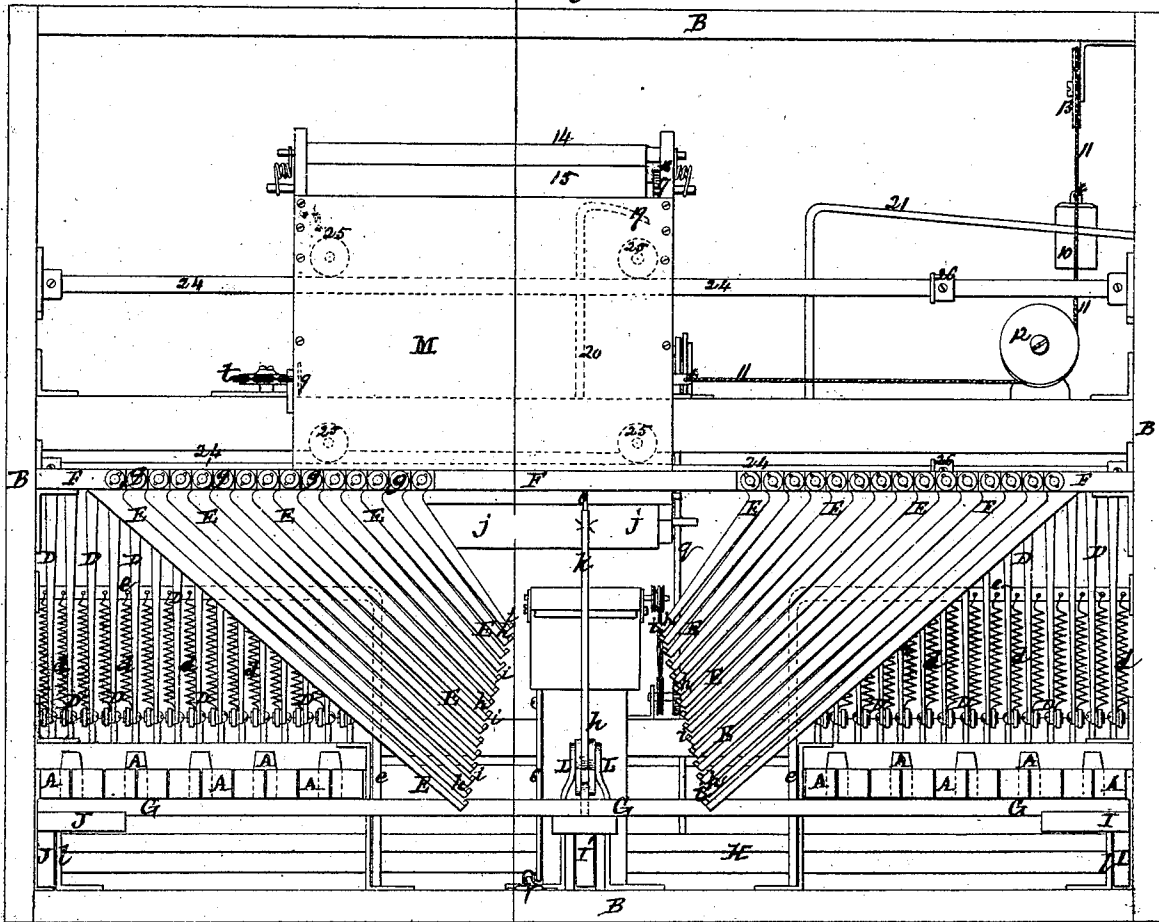
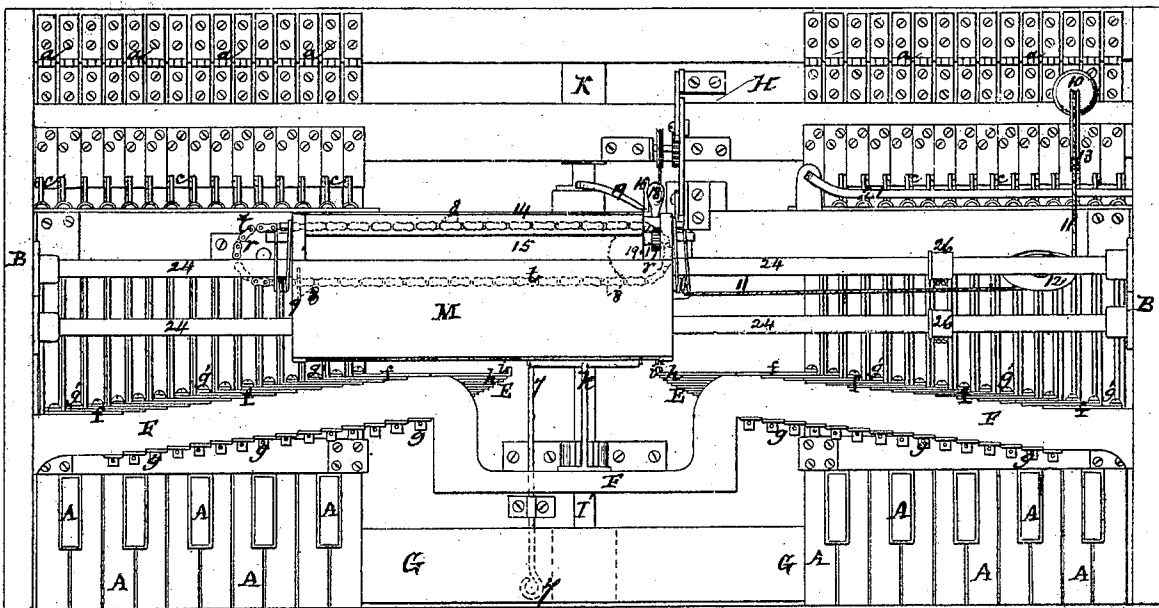

Fig. 2.



Witnesses.

Edmund Masson
Charles A. Washburn.
 By atty. *A. B. Stoughton.*

C. A. WASHBURN.
TYPE WRITING MACHINE.

No. 109,161.

Patented Nov. 8, 1870.

Fig. 3.

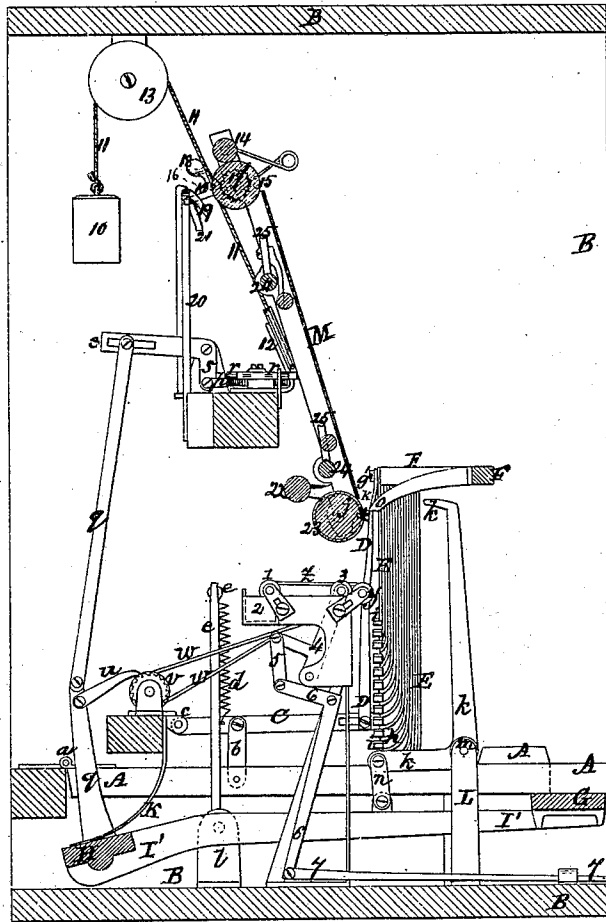
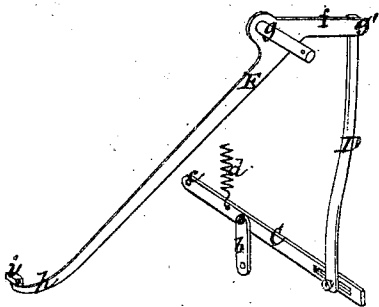

Fig. 4.



UNITED STATES PATENT OFFICE.

CHARLES A. WASHBURN, OF SAN FRANCISCO, CALIFORNIA.

IMPROVEMENT IN TYPE-WRITING MACHINES.

Specification forming part of Letters Patent No. 109,161, dated November 8, 1870.

To all whom it may concern:

Be it known that I, CHARLES A. WASHBURN, of San Francisco, in the county of San Francisco and State of California, have invented certain new and useful Improvements in Machines for Printing or Writing by hand; and I do hereby declare the following to be a full, clear, and exact description of the same, reference being had to the accompanying drawings, making a part of this specification, in which—

Figure 1 represents a front elevation of the machine. Fig. 2 represents a top plan of the machine, the cover being removed. Fig. 3 represents a vertical section taken through the red line *x x* of Fig. 1, and showing the parts to the right of said line. Fig. 4 represents in perspective, and detached from the machine, one of the type-levers and its appliances.

Similar letters of reference, where they occur in the several separate figures, denote like parts of the machine in all of the drawings.

This invention relates to a class of machines wherein lettered or otherwise marked keys are touched or struck by hand, to cause an arm or lever carrying a corresponding letter or mark to strike the paper or other thing to be marked or printed upon, in a given or regulated line, so as to produce a printed or marked surface, such as may be desired. The feeding along of the paper or other material that receives the letters, marks, or indentations, as well as the supplying of ink or other colored matter to the types or other characters used, being automatic, as will be explained.

And my invention consists, first, in combining with a series of lettered or otherwise marked keys a series of levers of differing lengths, and pivoted at varied distances from the printing or impressing point, and furnished with letters or marks corresponding to those on the keys, so that, when actuated, each lever of the series shall bring its lettered or marked end over or upon one and the same point to leave its impression.

My invention further consists in combining with a series of type-levers and a striker for forcing their type or other characterized end against the paper or other article to be impressed, a stop for preventing the momentum of said levers from carrying them beyond the

point where the striker acts, or the impression is to be taken.

My invention further consists in combining with a series of type-levers furnished with type or other characters or marks an inking mechanism for supplying them with ink as they are moving to the point where the impression is to be taken.

To enable others skilled in the art to make and use my invention, I will proceed to describe the same with reference to the drawings.

A series of finger-keys, *A A A*, &c., corresponding in number to the letters of the alphabet, together with such other marks, characters, or numerals as are ordinarily used in printing or writing, is arranged in the case or frame *B*, and pivoted or hinged at their rear ends *a a a*, &c., so that they may move downward under the pressure of the finger of the operator. To each one of the keys *A* there is connected by a link, *b*, a lever, *C*, which is hinged or pivoted at *c*, so that in pressing down a key its lever shall also descend. And to each of the levers *c* there is connected one end of a coiled or other spring, *d*, the other end of which is fastened to a rigid piece or frame, *e*, so that the descent of the lever will expand the spring, and the reaction of said spring, when the key is relieved of the pressure, return said lever and key to its normal position. To the free ends of the series of levers *C* are attached respectively the lower ends of a series of connecting rods or bars, *D*, the upper ends of which are attached to the short arm *f* of its respective type-lever *E*, which are also in series capacity, and pivoted to the metallic frame-piece *F*, as shown at *g g g*, &c. The positions of the type-levers *E* are shown in Figs. 1 and 2, and are pivoted in an oblique line, so that any one of the series may move to and from the printing or impressing point * shown in Figs. 1, 3, without interfering with any of the others. These type-levers are of varied lengths, but the type end *h* of all of them when thrown up comes exactly over or opposite one and the same point, which point I have termed the printing or impressing point, and marked with a *. The free end of each of the type-levers has upon its side a type, mark, or other character, *i*, which is moved laterally to the swinging motion of the type-lever, to make its impres-

sion upon the paper or other article that lies on or against the padded or cushioned roller *j*, and which receives the impulse of the blow given to the type-lever by the striker *k*, which will be hereafter described. The connecting-rods *D* are pivoted respectively to the short arms of the levers, which they operate at the points *g' g' g'*, said levers working like bell-crank levers.

As the levers *E* increase in length, and are pivoted more and more distant from the printing-point, they are curved or bent the more at their lower extremities, to bring their lower ends more into, or exactly into, the line, out of which their upper ends are necessarily taken, that they may have space to move in without striking or interfering with each other's movements.

Underneath the keys *A* there is a vibrating frame composed of a front and rear longitudinal piece, *G H*, and side pieces *I J*, which side pieces are pivoted to brackets *l* attached to the case *B*. A spring, *K*, presses upon the rear portion *H* of this frame, to keep it in the position shown in Fig 3, said rear being also weighted to aid in keeping the frame in such position as shown. Any of the keys of the series, on being pressed down, comes against the front portion *G* of this vibrating frame, and as the pressure is continued the frame itself goes down with the key, it being so nearly balanced as to require but little pressure to move it on its pivoted points at *l*. The downward motion of the frame works the striker *k*, while the return motion operates the feed-motion that carries the paper past the printing-point, as will be hereinafter more particularly described.

The striker *k*, more distinctly seen in Fig. 3, is pivoted at *m* to an upright or post, *L*. The short and horizontal arm or portion of the striker is linked, as at *n*, to an arm, *I'*, projecting forward from the center of the rear piece *H* of the vibrating frame, so that as said frame descends with the key, or any key, it brings the upper end of the striker against the type-lever that the pressure upon any one of the keys may have brought up to that point, and the blow or pressure of the striker upon such type-lever moves the type-lever laterally, and causes its type, mark, or character to be impressed upon the paper or other article, and the spring or reaction of the lever from the blow or tap upon it, returns it to its natural working position again. And that the momentum of the type-levers, as they are thrown up, may not carry them so far as not to be struck by the striker at the proper time and place, a stop, *o*, is arranged, against which each lever brings up just in time and place to be struck by the striker, and leave the impress of its type or character upon the paper, or other article. As the vibrating frame drops in front and rises in the rear it draws back a dog, *p*, that works in a ratchet formed on the sprocket or chain-wheel *r*, and when released, or as it returns to its state of rest, it operates

said dog through the connecting-rod *q* and bell crank-lever *s*, which dog in turn moves the chain-wheel *r*, and this moves the chain *t*, which in turn carries the paper-table *M* and its appliances. The connecting-bar *q* also carries a dog, *u*, that works in a ratchet, *v*, which is on the same shaft with the pulley around which an endless band, *w*, passes, and which transmits motion to the inking-roller *y*, and from a pulley on this roller an endless band, *z*, passes around a pulley on a supply-roller, *1*, that works in the ink-fountain 2. A traveling ink-roller, *3*, moves from the roller *y* to the roller *1* to carry the ink from the former to the latter, which traveling roller turns on its axis when it is brought into contact with those *1* and *y*. To move the traveling roller *3* a crank and link connection, *4 5 6*, is arranged and connected with a rod or bar, *7*, that extends to the operator's position in front of the machine, so that the roller *3* may be moved from the supply to the inking-roller, and vice versa.

On the endless chain *t* there are three tappets, *8*, so arranged and spaced that each one in turn will catch against a shoulder or projection, *9*, on the paper table or carrier *M*, and move said table to the left to the extent of its traverse in that direction, and as the table or paper-carrier so moves, it raises up a weight, *10*, that is upon the end of a cord or chain, *11*, that is attached to said table or carrier, and passes under the pulley *12* and over the pulley *13*. When the chain passes around the sprocket or chain wheel at the end of its traverse, the tappet then moving the table or carrier leaves the projection *9*, the table is released from the carrying-chain, and the weight *10* falling draws back the table *M* for the next succeeding similar operation. At the top of the paper-table *M* are two rollers, a small one, *14*, and a larger one, *15*, the two being held in contact by the pressure of a spring. On the journal at the right-hand end of the roller *15* there is connected an arm or lever, *16*, by means of a collar passing loosely around said journal, and upon this same journal close to the collar there is rigidly fixed a ratchet, *17*, in which a weighted pawl, *18*, works, to turn the roller at the proper time and place to draw the paper up one line or space, when it returns to begin a new line, as follows: Just before the paper-carrier *M* arrives at the end of its traverse to the left, the lever *16* comes in contact with an inclined plane, *19*, on a post or standard, *20*. As the table continues toward the end of its traverse in this direction, the lever *16* is raised up by mounting this incline *19*, and in rising up it carries with it the weighted pawl *18*, which is pivoted to it, and allows the pawl to take a new position on the ratchet. When the table is released from the carrying-chain, as above described, and is run back by the falling of the weight *10*, the lever *16* passes under a guide or downwardly-inclined rail or bar, *21*, which draws it, and with it the pawl *18*, downward, and causes said

clined rail or bar, 21, which draws it, and with it the pawl 18, downward, and causes said pawl, which was previously set in the ratchet for a feeding movement, to slightly turn the roller 15, and draw up the paper sufficiently far to space the next line to be printed. This done, the tappet on the chain begins to move the table along for another succeeding printing operation.

At the bottom of the paper-table M there are two rolls, a smaller one, 22, and a larger one, 23, and a friction spring or brake on the roller 22 prevents it from turning until the friction is overcome by the tension upon the paper, when it turns and allows the paper to be fed up for spacing the lines.

Extending across the frame or case are two round rails, 24, upon which the paper-table is guided and moves, the rails passing through lugs on the paper-table frame, and to avoid undue friction in moving the paper-table or carrier upon said rails friction-wheels 25, attached to said table, run upon the tops of said rails.

The paper to be printed upon may be rolled upon the roller 22, and thence passing under the roller 23, thence up and upon the face of the paper carrier or table M, and between the pressure and feeding rolls 14 15, where it is caught and drawn up intermittently as the printing progresses, and as described, or an apron or tapes may extend from the lower to the upper rollers, and the paper be caught upon and moved by said apron or tapes.

It will be perceived by reference to Figs. 1 and 2 that there is a considerable portion of the bar G, which is a part of the heretofore-described vibrating frame, at the position where the operator stands or sits, that is not covered or occupied by the keys A. When this frame is moved by the keys, it, by its connections, spaces the distances between the letters printed, but not between the words, which latter space is greater than that between the letters. When, therefore, a word is completed, the operator with his hand, and without moving, or distributing the keys, gives the frame two or more vibrations, which moves the paper along sufficiently to give the proper space between the words, and this arrangement of the bar, keys, type-levers, and paper table or carrier is very important, inasmuch as the printing is done in full fair sight, always, of the operator, so that he may always, and at any time, see the work that is done, and stop or correct it when it is necessary to do so. All its workings are in full fair view of the operator, and an error or a misprint could not go unobserved.

When the paper table or carrier is run back by the falling of the weight 10 its momentum,

if suddenly arrested, might, by jarrings, disarrange some of the parts and make unpleasant noise. To avoid this I arrange upon the rails 24 rubber springs, pads, or cushions 26 to stop the table at the end of its traverse in that direction in which the weight moves it.

While this machine has been described only for printing, it could be used for making stereotype-matrices by impressing its type in some suitably soft or pliable material, such, for instance, as *papier maché*, into which, when dried, the type-metal could be run to make the stereotype-plate.

If it be desirable to duplicate the type-levers, so that one set may contain capital letters only, and the other set small letters, it can be readily done by arranging the second or duplicate set above those shown in the drawing, and so that the striking of the keys corresponding thereto will swing them downward and then against the paper as the set herein shown swings upward to do the same thing. This, however, would amount to doubling the machine, which I have herein described and shown, and I would regard the so doubling or duplicating the type-levers and keys as a part and parcel of my invention, and an obvious addition to the machine I have invented.

Having thus fully described my invention, what I claim therein as new, and desire to secure by Letters Patent, is—

1. In combination with a series of lettered or otherwise marked keys, a series of levers of differing lengths, and pivoted at varied distances from the printing or impressing point, and furnished with letters or marks corresponding to those on the keys, respectively, to which they are attached, so that, when actuated, each lever of the series shall bring its lettered or marked end over or upon one and the same point or position to leave its impression, substantially as described.

2. In combination with a series of type-levers, and a striker common to all, for forcing the type ends thereof against the paper or other article to be impressed, a stop that is also common to all the levers for preventing the levers in rising from being carried beyond the exact point where the impression is to be taken, substantially as described.

3. In combination with the series of type-levers of differing lengths and hung in different planes, an inking-roller, against which the type of each lever moves as it is swung into position for printing action, substantially as described.

CHARLES A. WASHBURN.

Witnesses:

A. B. STOUGHTON,
EDMUND MASSON.