

12

EUROPEAN PATENT APPLICATION

21 Application number: 87303017.5

51 Int. Cl.4: **B65D 71/00**

22 Date of filing: 07.04.87

30 Priority: 08.04.86 US 849548

43 Date of publication of application:
21.10.87 Bulletin 87/43

84 Designated Contracting States:
AT BE CH DE ES FR GB GR IT LI NL SE

71 Applicant: **ILLINOIS TOOL WORKS INC.**
8501 West Higgins Road
Chicago Illinois 60631(US)

72 Inventor: **Olsen, Robert Charles**
6N240 James Court
Medinah, 60157 Illinois(US)
Inventor: **Boone, Edward Jenkins**
6N447 Pinto Lane
St. Charles, Illinois 60174(US)

74 Representative: **Rackham, Stephen Neil et al**
GILL JENNINGS & EVERY 53-64 Chancery
Lane
London WC2A 1HN(GB)

54 **A package.**

57 A package of a relatively large number of containers (16) arranged in ranks and rows interconnected by a first packaging device (12) which includes a number of container encircling bands (26) which resiliently engage an intermediate portion of the containers (16) and a second packaging device (14) comprising a unitary, endless strip resiliently encircling the outer periphery of the containers (16) adjacent the first packaging device (12).

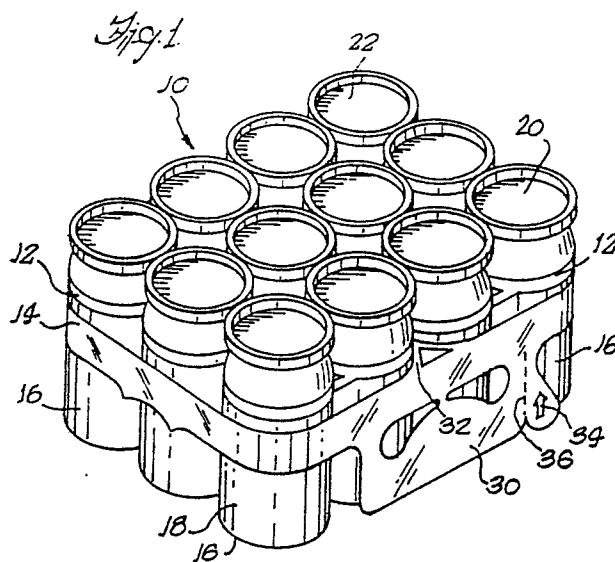

A Package

The present invention relates generally to a package for a plurality of containers and more specifically to a multi-unit package containing a relatively large number of containers, for example twelve, which can be carried easily and reliably.

Multi-unit package carriers are well-known. Typical multi-unit package carriers for can-type containers are shown in U.S.-A-4,269,308 and U.S.-A-4,520,924. Such multi-unit packages comprise a plurality of can-type containers arranged in an array of rows and ranks, each container including a generally cylindrical side wall with a predetermined perimeter dimension connected to a top lid which incorporates a radially extending chime with a predetermined perimeter dimension, a first packaging means comprising a plurality of container encircling bands interconnected by webs in resilient engagement with the containers, a second packaging means comprising an endless resilient plastic strip encircling the array of containers, the strip having a predetermined width substantially greater than its thickness and being unconnected to the first packaging means, the strip being arranged with its width dimension extending generally parallel to the axis of the containers.

In such conventional packages the first packaging means engages beneath the radially extending chime at the top of the containers. Such carrier devices have been found to be advantageous and economical. However, in packaging a large number of containers, such as twelve, it has been found that the containers tend to move relative to one another which makes the carrying device unstable and somewhat difficult to handle.

According to this invention in such a package the container encircling bands of the first packaging means are located substantially below the chime of the container at an intermediate portion of its cylindrical sidewall and adjacent the second packaging means.

The package in accordance with this invention provides a package of a plurality of containers which are tightly unitised and which cannot easily be separated into subpackaging units and in which any movement of the containers relative to each is minimised.

Two examples of packages in accordance with this invention will now be described and contrasted with the prior art with reference to the accompanying drawings, in which:-

Figure 1 is a perspective view of a first example of package in accordance with the present invention;

Figure 2 is a partial side elevation view of a prior art package;

Figure 3 is a partial side elevation of a package in accordance with this invention;

Figure 4 is a plan of the second packaging device before application;

5 Figure 5 is a perspective view of a second example of package in accordance with the invention;

Figure 6 is a plan of the second example of package; and,

10 Figure 7 is a fragmentary enlarged partial section taken along the line 7-7 shown in Figure 6.

Turning now to the drawings, wherein like components are designated by like reference numerals throughout the various Figures, Figures 1 and 5 show a multi-unit package 10. The package 10 includes a first packaging device 12 and a second packaging device 14 cooperating to unitise a plural-
15 ity of containers 16.

Typical containers which are effectively used in this invention are can-type containers 16 having a cylindrical sidewall 18, a top lid 20 and an annular chime or end seam 22 forming a perimeter on the top lid 20.

As illustrated in Figure 6, the first carrier device or sub-packaging device 12 is generally similar to the type shown in prior art U.S. Patent Nos. 2,874,835; 3,874,502 and 4,219,117. These sub-packaging devices are typically polyethylene having a plurality of container encircling bands 26 encircling apertures 24 interconnected by web-regions 27. The apertures 24 in blank form are smaller in circumference than the circumference of the body of the containers 16 which they are to be associated with so that they resiliently engage and retain the container therein. It should be noted that the preferred device 12 is designed to package 6 or 12 containers. In other words the package 10 may include two separate "6-pack" devices 12 or a single device 12 capable of retaining the cans in an array of 3 ranks and 2 rows or 3 ranks and 4 rows respectively, creating a sub-package unit. However, packages containing different numbers of containers may be made in accordance with this invention.

As shown in Fig. 2, the sub-packaging device 12' in the prior art, was constructed and positioned to resiliently engage beneath the chimes or end seams 22 to unitize a predetermined plurality of such containers 16 to form a sub-package unit. The placement of the sub-packaging carrier 12' beneath the end seams 22, unitizes a plurality of cans, but does not tightly hold the body of the cans together. The body of the containers 16 are free to move in a pistoning or axial and skewing manner relative to another. When the second carrier device 14 is placed around a predetermined plurality of sub-
45
50

packaging units, the units may also move relative to one another in such a pistoning and skewing manner. Movement of the containers relative to one another as well as the movement of the sub-packaging units relative to one another makes the multi-packaging carrier 10, somewhat unstable and difficult to handle.

Turning to Fig. 3, in accordance with the present invention, the sub-packaging carriers 12, are constructed to resiliently engage a mid-section of the containers 16 to tightly unitize a predetermined array of containers. In typical assembly operation, stretching jaws deform the sub-packaging device 12 over the tops of a plurality of containers down to a predetermined mid-portion of each associated container forming a sub-package unit. In blank form, the internal and external diameters of the web-regions 26 are less than the diameter of the body of the container 16. In assembly, when the web-regions 26 are stretched over the container 16, down to said mid-section of the containers the width of the web-region sections is stretched so that it lays flat against the circumference of the sidewalls 18, and grabs the sidewalls 18 holding the cans in place. This engagement creates and enhances a substantial frictional engagement between each of the individual containers 16. Positioning the sub-packaging carriers as shown in Fig. 3, greatly reduces the pistoning and skewing effect of the cans relative to one another and the pistoning and skewing movement of the sub-packaging units relative to one another. A further advantage in positioning the sub-packaging carriers 12 at a mid-section of the containers, is that the sub-packaging units cannot be readily grasped and handled as a sub-package unit, whereby to ensure usage of the package in the manner intended.

As illustrated best in Fig. 4, the second or multi-packaging device 14 generally of the type shown in the prior art in U.S. Patent Nos. 4,269,308 and 4,520,924, is comprised of an endless thermoplastic strip or band device 28, typically resilient polyethylene and generally oval shaped. The device 28 is formed with a handle 30 and intermediate transverse strap means 32, which is preferably located midway of the longitudinal extremities of the band and interconnects the opposite sides of the band. The band device 28 is preferably located about midway between the top and the bottom of the containers adjacent the carrier 12. The band 28 has a predetermined width and thickness, with the thickness being substantially less than the width. The band is dimensioned so that it can be stretched over and encircle the outer perimeter of a predetermined plurality of cans or sub-package units to create a unitizing and securing pressure on the sidewalls 18 of the outer periphery of the containers 16.

The intermediate strap 32 can be of any desired configuration of the type shown in U.S. Patent Nos. 4,520,924, 4,385,690 or 4,385,691. The strap 32 is constructed to be of a length greater than the width of the band 28 in blank form to accommodate the need to stretch the band 28 laterally to be telescopically associated with the plurality of sub-packaging units.

The handle 30 is formed at the outer periphery of the band 28, and lies flat adjacent to the sidewalls 18 of the containers 16. This allows for easy storing. The handle 30 has a tab portion 34 which can be easily pulled upward along the scored line 36. As shown in Fig. 5, once the tab 34 is pulled upward the handle 30 can be easily bent in a position perpendicular to the sidewalls 18 of the containers 16 for easy grasping and carrying.

As shown in Fig. 7, the web-regions or interconnecting bands 26 of the device 12, are pressed together in the package and integrally joined at a juncture 27 between the mid-portion of the body of the containers 16. This structure prevents the center portions of the containers 16 from separating from each other during handling of the package, which greatly minimizes the movement of the containers relative to one another. The tendency for containers to skew relative one another is further reduced because the ends of the adjacent containers will bump into each other when the opposite ends start to separate minimizing the degree of lateral movement between the cans.

Positioning the encircling band 28 around the mid-portion of the outer periphery of the containers 16, further reduces the movement of the containers and when used in combination with the sub-packaging devices 12 greatly increases the stability of the multi-package container.

Claims

1. A package (10) comprising a plurality of can-type containers (16) arranged in an array of rows and ranks, each container (16) including a generally cylindrical sidewall with a predetermined perimeter dimension connected to a top lid (20) which incorporates a radially extending chime with a predetermined perimeter dimension, a first packaging means (12) comprising a plurality of container encircling bands (26) interconnected by webs (27) in resilient engagement with the containers (16), a second packaging means (14) comprising an endless resilient plastic strip (28) encircling the array of containers (16), the strip (28) having a predetermined width substantially greater than its thickness and being unconnected to the first packaging means (12), the strip (28) being arranged with its width dimension extending generally parallel to the

axis of the containers (16), characterised in that the container encircling bands (26) of the first packaging means (12) are located substantially below the chime (22) of the container at an intermediate portion of its cylindrical side wall and adjacent the second packaging means (14). 5

2. A package according to Claim 1, wherein the array comprises twelve containers (16) arranged in four ranks of three rows.

3. A package according to Claims 1 or 2, wherein the first packaging means comprises a pair of discrete devices, each having half the number of container encircling bands (26) interconnected by webs (27) as there are containers (16) in the package (10). 10 15

4. A package according to any one of the preceding Claims, wherein the encircling strip (28) is located substantially midway between the top and bottom of the containers (16).

5. A package according to any one of the preceding Claims, wherein the encircling strip (28) is formed from a flat sheet material as an oval-shaped band (28), the second packaging means (14) including a handle (30) extending from the outer edge of the band (28). 20 25

30

35

40

45

50

55

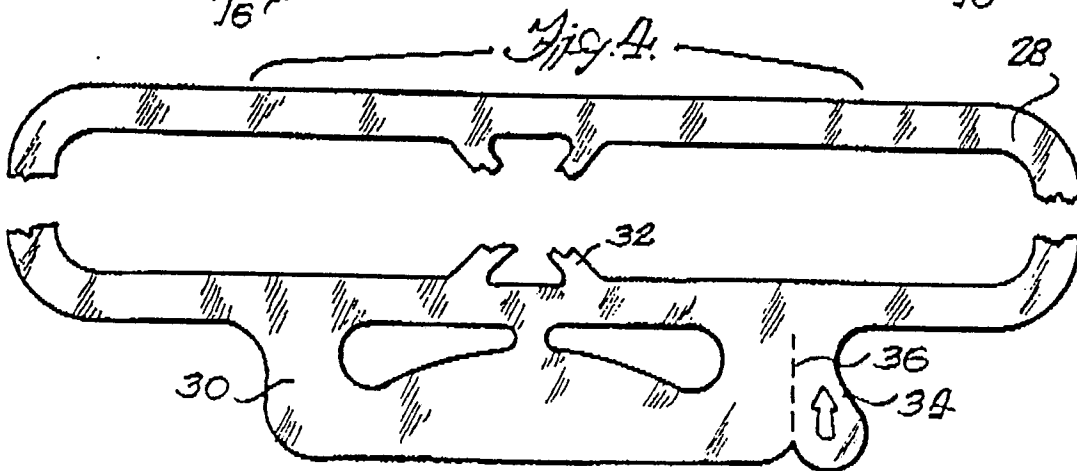
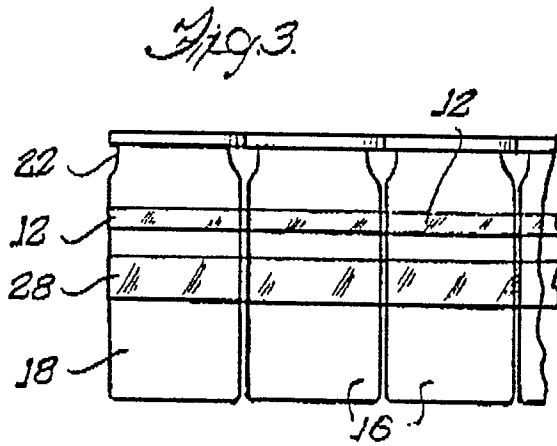
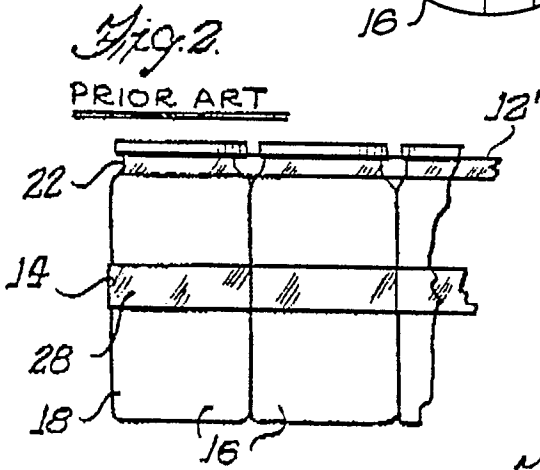
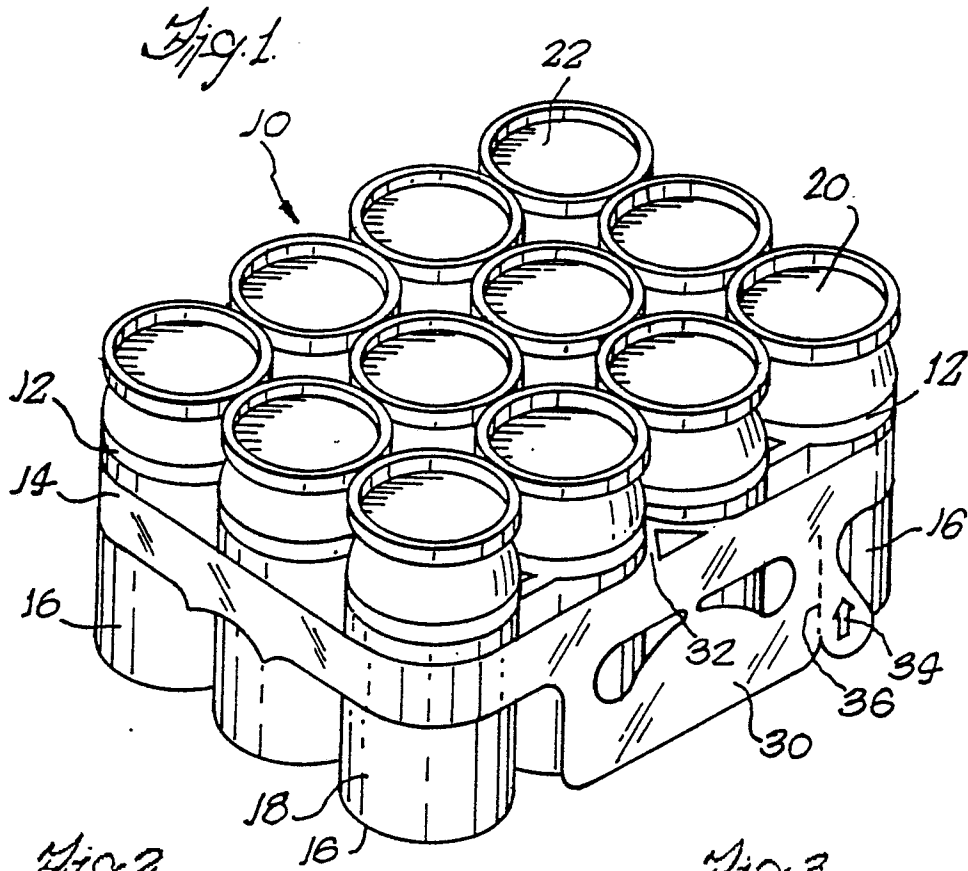

Fig. 5.

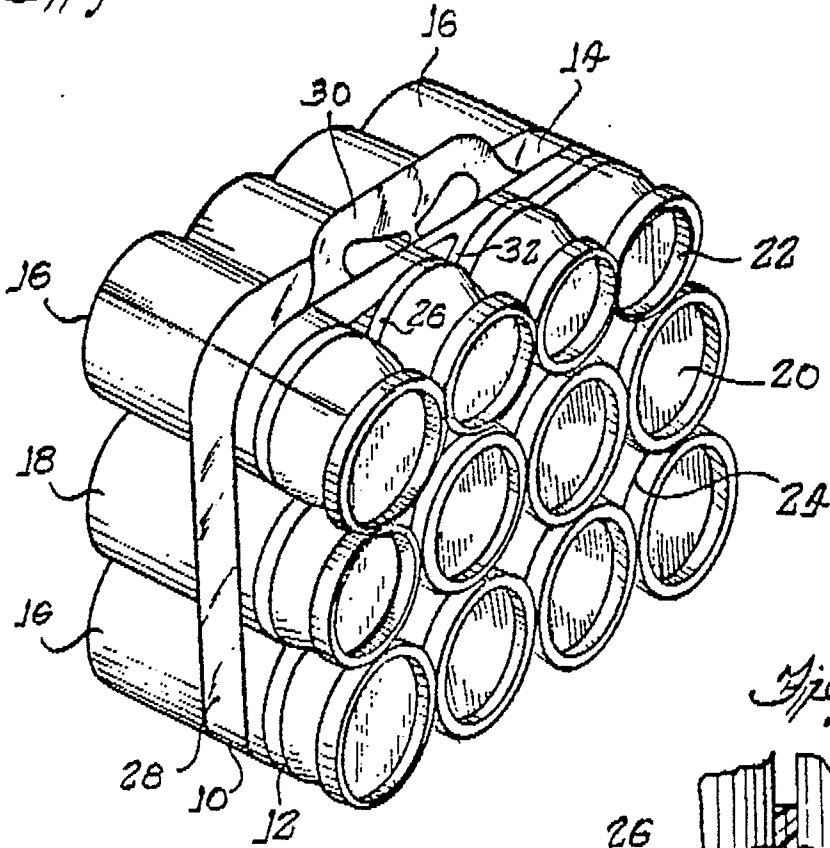

Fig. 7.

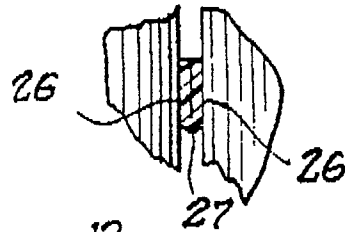

Fig. 6.

