

No. 849,965.

PATENTED APR. 9, 1907.

J. S. BLACKWOOD.
DUMPING WAGON.
APPLICATION FILED DEC. 28, 1906.

2 SHEETS—SHEET 1.

Fig. 1.

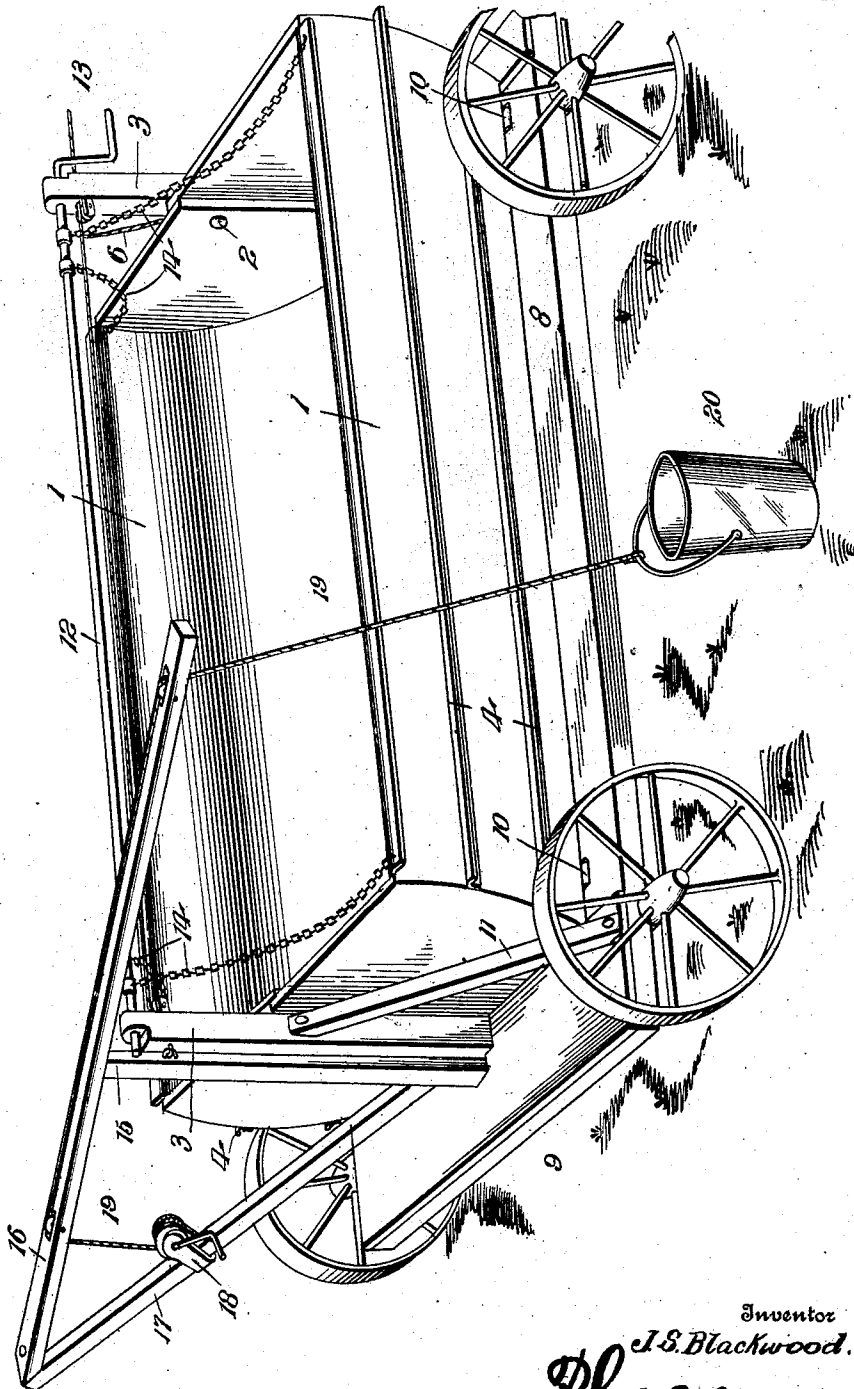

Witnesses

J. M. ...
W. P. ...

Inventor

J. S. Blackwood.

By

R. H. ...

Attorneys

No. 849,965.

PATENTED APR. 9, 1907.

J. S. BLACKWOOD.
DUMPING WAGON.
APPLICATION FILED DEC. 28, 1906.

2 SHEETS—SHEET 2.

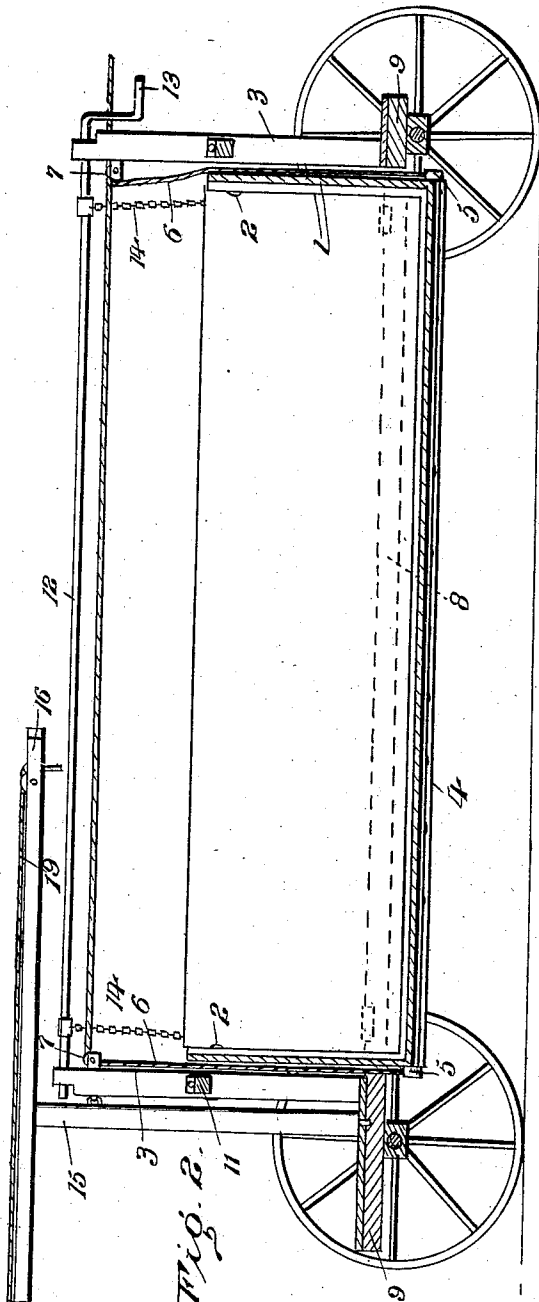

Fig. 2. B.

Fig. 3.

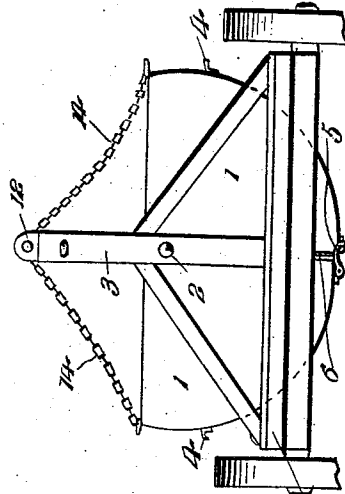
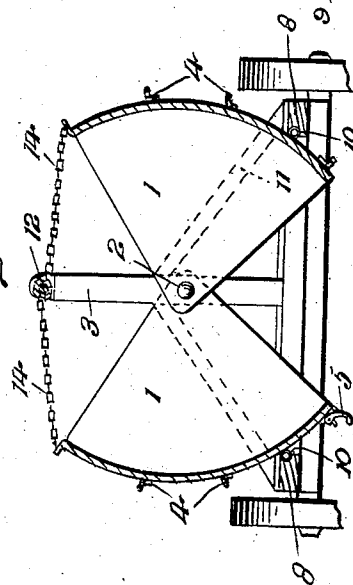

Fig. 4.



Witnesses

A. Minie
W. R. Woodson

Inventor

J. S. Blackwood

By

Pharmay

Attorneys

UNITED STATES PATENT OFFICE.

JACOB S. BLACKWOOD, OF COLUMBUS, INDIANA.

DUMPING-WAGON.

No. 849,965.

Specification of Letters Patent.

Patented April 9, 1907.

Application filed December 28, 1906. Serial No. 349,891.

To all whom it may concern:

Be it known that I, JACOB S. BLACKWOOD, a citizen of the United States, residing at Columbus, in the county of Bartholomew and State of Indiana, have invented certain new and useful Improvements in Dumping-Wagons, of which the following is a specification.

This invention relates to wagons embodying bodies for receiving a load, and which bodies are of sectional formation and mounted to admit of the sections separating to effect discharge of the load when it is required to dump the same.

The present invention has for its object to improve the general structure of wagons of the type aforesaid, whereby their usefulness is enhanced and the operation of opening and closing the sections of the body greatly simplified.

For a full description of the invention and the merits thereof and also to acquire a knowledge of the details of construction and the means for effecting the result reference is to be had to the following description and accompanying drawings.

While the invention may be adapted to different forms and conditions by changes in the structure and minor details without departing from the spirit or essential features thereof, still the preferred embodiment is shown in the accompanying drawings, in which—

Figure 1 is a perspective view of a dumping-wagon embodying the invention. Fig. 2 is a central longitudinal section of the wagon. Fig. 3 is an end view of the body, showing the side bars of the truck or running-gear in section and illustrating the relation of the parts when said body is closed. Fig. 4 is a transverse section of the wagon, showing the relation of the parts when the sections of the body are separated to dump the load.

Corresponding and like parts are referred to in the following description and indicated in all the views of the drawings by the same reference characters.

The body is composed of two similar sections 1, which are pivotally mounted to swing outward when it is required to dump the load, the sections being pivotally connected at 2 to each other and to supports 3, the latter rising from the framework of the truck or running-gear. The sections 1 of the body are preferably formed of sheet metal, the latter being suitably strengthened by angle-

bars 4, riveted or otherwise attached to the outer sides of the sections and extending lengthwise thereof. In the end view each section 1 is of sector shape, being approximately one-quarter of a circle, the outer side and bottom being formed on a circle having its center corresponding with a straight line connecting the pivot-supports 2. To hold the sections when closed, a catch 5 is provided at each end of the body and is pivoted to one of the sections and adapted to engage over projecting portions of the opposite section and which projecting portions constitute end extensions of the angle-bar 4, secured to the lower edge of the section. The catches 5 are connected, by means of a cord 6, which after passing over suitably-arranged guide-pulleys 7 extends within convenient reach of the driver's seat to admit of release of the catches when it is required to effect discharge of the load.

The framework of the truck or running-gear comprises side bars 8 and end pieces 9, the latter forming platforms, as well as serving to connect the side bars 8 at their ends. The supporting-wheels are applied to axles, which in turn are fitted to the framework in any accustomed way. The space between the side bars 8 and end cross-pieces 9 is such as to receive the body. Rollers 10 are located near opposite ends of the side bars and assist materially in supporting the body and relieve the pivot-fastening 2 of the carrier part of the strain and load. By having the pulleys 10 arranged adjacent to the end pieces 9 the weight of the load is transferred thereto through the end pieces of the sections 1, thereby preventing inward bending of the sides.

The posts 3 or uprights are secured at their lower ends to the end pieces 9 or bolsters and are strengthened by lateral braces 11. A stout rod 12 is mounted in the upper ends of the posts 3 and is provided at one end with a crank 13.

Chains or cables 14 connect end portions of the rod 12 with opposite corners of the body-sections 1. Upon turning the shaft 12 after releasing the catches 5 the chains or cables 14 are wound thereon and effect a separation of the sections 1, thereby permitting discharge of the load.

A crane 15 is located at one end of the wagon, and the post is slipped at its lower end in the end piece and is hingedly connected near its upper end to the proximal upright or

post. The boom or horizontal beam 16 of the crane is extended at one end and is connected by means of a brace 17 to the lower portion of the post. A windlass 18 is mounted upon the brace 17, and a cord or rope 19 is attached at one end of the windlass and adapted to wind thereon, the opposite end of said cord or rope being adapted to be attached to a bucket 20, into which the material is placed to be elevated and discharged into the body of the wagon.

A wagon constructed substantially as herein specified is adapted for carrying gravel, sand, material of any kind, garbage, or refuse matter, the wagon being loaded in any convenient way, either by means of the crane and bucket 20 or by pitching material into the body in any way commonly practiced for loading wagons of the type disclosed. When it is required to dump the load, the catches 5 are released and the rod 12 rotated by means of the crank-handle 15 to wind the chains or cables 14 thereon and draw the sections 1 apart, so as to permit automatic discharge of the load.

Having thus described the invention, what is claimed as new is—

1. In a dumping-wagon, the combination of a framework, comprising side bars and end pieces, uprights projected upward from said end pieces, a wagon-body comprising similar sector-shaped sections, means pivotally connecting said sections to each other

at their upper inner corners and to the respective uprights, rollers applied to the side bars of the framework adjacent to the end pieces to make contact with the sections of the body opposite the end pieces of the said body-sections, means for securing the sections of the body when closed, and means for opening said sections to effect discharge of the load.

2. In a dumping-wagon, the combination of a framework comprising side bars and end pieces, a body comprising similar sections pivotally connected and adapted to swing outward and upward, uprights at the ends of the framework, a rod journaled to said uprights and flexible connections between said rod and the sections of the body and adapted to effect an opening of the latter upon rotation of the said rod.

3. In a dumping-wagon, the combination of a framework, a body comprising sections adapted to open outward, bars applied to the sides of said sections for stiffening and strengthening the same and catches cooperating with certain bars to hold the sections when closed.

In testimony whereof I affix my signature in presence of two witnesses.

JACOB S. BLACKWOOD. [L. S.]

Witnesses:

ALBERT BROWN,
WILLIAM H. EVERWOOD.