



(51) International Patent Classification:

G01N 33/50 (2006.01) C12Q 1/68 (2006.01)
G01N 33/53 (2006.01) B01L 3/00 (2006.01)

(21) International Application Number:

PCT/US2014/032006

(22) International Filing Date:

27 March 2014 (27.03.2014)

(25) Filing Language:

English

(26) Publication Language:

English

(30) Priority Data:

61/806,425 29 March 2013 (29.03.2013) US
61/874,590 6 September 2013 (06.09.2013) US

(71) Applicant: **6SENSORLABS, INC.** [US/US]; 1209 Orange Street, Wilmington, Delaware 19801 (US).

(72) Inventors: **SUNDEVOR, Scott**; 43 Market Street, Unit A, Cambridge, Massachusetts 02139 (US). **WALTON, John**; 340 Franklin Street, Apt. 4, Cambridge, Massachusetts 02139 (US). **KIEL, Jonathan William**; 643 Woodcrest Avenue, Ardmore, Pennsylvania 19003 (US). **MEKLER, Jeffrey**; 150 Allston Street, Cambridge, Massachusetts 02139 (US). **TALEGHANI, Shireen**; 2001 McAllister Street, Apt. 252, San Francisco, California 94118 (US).

MOONEY, Jacob; 62 Buckboard Drive, Westford, Massachusetts 01886 (US).

(74) Agents: **SCHOX, Jeffrey** et al.; Schox PLC, 500 3rd Street, Suite 515, San Francisco, CA 94107 (US).

(81) Designated States (unless otherwise indicated, for every kind of national protection available): AE, AG, AL, AM, AO, AT, AU, AZ, BA, BB, BG, BH, BN, BR, BW, BY, BZ, CA, CH, CL, CN, CO, CR, CU, CZ, DE, DK, DM, DO, DZ, EC, EE, EG, ES, FI, GB, GD, GE, GH, GM, GT, HN, HR, HU, ID, IL, IN, IR, IS, JP, KE, KG, KN, KP, KR, KZ, LA, LC, LK, LR, LS, LT, LU, LY, MA, MD, ME, MG, MK, MN, MW, MX, MY, MZ, NA, NG, NI, NO, NZ, OM, PA, PE, PG, PH, PL, PT, QA, RO, RS, RU, RW, SA, SC, SD, SE, SG, SK, SL, SM, ST, SV, SY, TH, TJ, TM, TN, TR, TT, TZ, UA, UG, US, UZ, VC, VN, ZA, ZM, ZW.

(84) Designated States (unless otherwise indicated, for every kind of regional protection available): ARIPO (BW, GH, GM, KE, LR, LS, MW, MZ, NA, RW, SD, SL, SZ, TZ, UG, ZM, ZW), Eurasian (AM, AZ, BY, KG, KZ, RU, TJ, TM), European (AL, AT, BE, BG, CH, CY, CZ, DE, DK, EE, ES, FI, FR, GB, GR, HR, HU, IE, IS, IT, LT, LU, LV, MC, MK, MT, NL, NO, PL, PT, RO, RS, SE, SI, SK, SM,

[Continued on next page]

(54) Title: A PORTABLE DEVICE FOR DETECTION OF HARMFUL SUBSTANCES

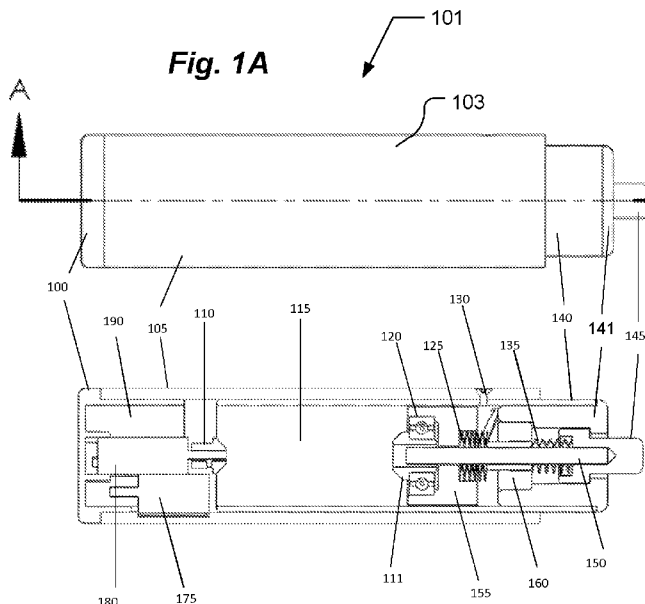

Fig. 1B

(57) Abstract: A self-contained apparatus and methods for detecting the presence of any specified substance in any medium. A sample of the medium is placed in a capsule, along with a solvent and a sensor configured to test for a target analyte. The solvent comes into contact with the medium in the capsule, and the capsule is agitated to create a dispersion in the solvent of a portion of any target analyte present in the medium. A release mechanism configured to cause conduction of the dispersion to the sensor, so that the sensor produces an indication of presence of the target analyte if the target analyte is present in the medium. The apparatus uses a disposable capsule where the medium in question is placed and the disposable capsule is placed inside a reader and analyzed for presence of the harmful substance.



TR), OAPI (BF, BJ, CF, CG, CI, CM, GA, GN, GQ, GW, — *with amended claims (Art. 19(1))*
KM, ML, MR, NE, SN, TD, TG).

Published:

— *with international search report (Art. 21(3))*

Date of publication of the amended claims: 18 December
2014

AMENDED CLAIMS

received by the International Bureau on 13 October 2014 (13.10.2014)

1. A method for testing a medium for the presence of a target analyte, the method comprising:

- receiving the medium in a capsule, the capsule characterized by a volume, wherein receiving comprises providing the capsule with a solvent and a sensor configured to test the medium for the target analyte;
- causing the solvent to come into contact with the medium in the capsule;
- agitating the capsule, at a mixing apparatus of an analysis device in communication with the capsule, thereby agitating the solvent and the medium within the capsule and creating a dispersion in the solvent of any portion of the target analyte present in the medium;
- operating a release mechanism of the analysis device, configured to cause conduction of the dispersion to the sensor of the capsule; and
- providing an indication of presence of the target analyte upon detection of presence of the target analyte in the medium, by way of the sensor.

2. The method according to Claim 1, wherein providing the capsule comprises providing the capsule with at least a portion of the sensor ~~is visible~~ outside of the volume of the capsule, and wherein providing the indication comprises detecting presence of the target analyte at the sensor, outside of the volume of the capsule.

3. The method according to Claim 1, wherein operating the release mechanism comprises actuating ~~is~~ a valve disposed in a fluid path between the

volume of the capsule and a portion of the sensor disposed outside of the volume of the capsule.

4. The method according to Claim 1, wherein providing the capsule comprises providing the capsule with the sensor is disposed at least partially inside the capsule volume.

5. The method according to Claim 1, wherein agitating the capsule comprises providing agitation of mixing enhancers within the capsule by a motor of the mixing apparatus.

6. The method according to Claim 1, further comprising:

- providing the solvent in a separate chamber within the capsule; and
- activating a valve to release the solvent to come in contact with the medium.

7. The method according to Claim 6, wherein activating the valve includes actuating the valve by at least one of a mechanical actuator and an electromechanical actuator of the analysis device.

8. The method according to Claim 6, wherein activating the valve includes actuating the valve at least in part by a force applied by a user.

9. The method according to Claim 1, further comprising passing the solvent through a filter prior to conducting the dispersion to the sensor.
10. The method according to Claim 5, further comprising operating the mixing apparatus from outside the capsule.
11. The method according to Claim 5, wherein agitating includes providing power to the mixing apparatus by an electromechanical actuator of the analysis device.
12. The method according to Claim 5, wherein agitating includes providing power to the mixing apparatus as facilitated by a user of the analysis device.
13. The method according to Claim 1, wherein providing an indication of presence of the target analyte comprises receiving, through at least one of physical, electronic, and electromagnetic methods, the capsule within an outside housing, at the analysis device, in such a manner as to provide for reading of the sensor of the capsule.
14. The method according to Claim 1, further comprising: transmitting a test result electronically, or electromagnetically, to an external device.

15. The method according to Claim 1, wherein receiving the medium comprises receiving a consumable including at least one of a food sample and a medicine sample.
16. The method according to Claim 1, wherein receiving the medium comprises receiving a substance that will come into contact with human or animal skin, including at least one of a lotion, a cosmetic, and a soap sample.
17. The method according to Claim 1, wherein providing the indication of presence of the target analyte comprises providing indication of presence of a food allergen in the medium.
18. The method according to Claim 1, wherein providing the indication of presence of the target analyte comprises providing indication of presence of at least one of caffeine, phenylalanine, aspartame, MSG, heavy metals, artificial flavors, and artificial colors in the medium.
19. The method according to Claim 1, wherein providing the indication of presence of the target analyte comprises providing indication of presence of wheat protein, in the medium.
20. A self-contained portable analysis device comprising:
 - a housing;

- a capsule insertion port disposed in the housing for releasably receiving a capsule configured to retain a medium;
- a sensor holder for retaining a sensor, the sensor holder configured to bring the sensor into contact with contents of the capsule, processed from the medium; and
- a release mechanism, disposed within the housing and coupled to a valve gating contact configured between the contents processed from the medium of the capsule and the sensor, the release mechanism configured to cause contact between the contents of the capsule and the sensor.

21. The self-contained portable analysis device in accordance with Claim 20, further comprising a filter disposed in a path traversed by contents of the capsule antecedent to contact with the sensor.

22. The self-contained portable analysis device in accordance with Claim 20, wherein the sensor holder is configured to couple with the capsule.

23. The self-contained portable analysis device in accordance with Claim 20, further comprising an electromechanical actuator, coupled to the housing, configured to cause mixing of the medium and a solvent, configured to extract a target analyte from the medium, within the capsule.

24. The self-contained portable analysis device in accordance with Claim 20, further comprising a transparent viewport allowing the result from the sensor to be read from outside the housing.

25. A capsule for use in a self-contained portable analysis device, the capsule comprising:

- an enclosed volume for retaining a solvent and a medium sample;
- a cap adapted to permit introduction of the medium sample into the enclosed volume by a user; and
- a sensor holder for retaining a sensor and adapted for bringing the sensor in contact with contents, processed from the medium sample and the solvent, of the capsule.

26. The capsule in accordance with Claim 25, further comprising a valve adapted to gate contact between contents, derived from the medium sample and the solvent, of the enclosed volume and the sensor.

27. The capsule in accordance with Claim 25, further comprising a filter disposed between contents, derived from the medium sample and the solvent, of the enclosed volume and the sensor.

28. The capsule in accordance with Claim 25, further comprising a metering element built into at least one of the cap and the capsule, the metering element

adapted to permit a specific volume or weight of medium sample into the enclosed capsule volume.

29. The capsule in accordance with Claim 25, further comprising a separate chamber, in communication with the enclosed volume, adapted for introduction of the solvent into the enclosed volume and for withdrawal of the solvent from the enclosed volume upon actuation of a valve.

30. The capsule in accordance with Claim 25, further comprising a mixer for mixing the medium and solvent.

31. The capsule in accordance with Claim 25, wherein the capsule comprises a grinder configured to process the medium within the capsule.