

C. W. LEVALLEY.

Machine for Separating Metal from Grain.
No. 222,191. Patented Dec. 2, 1879.

Fig. 1.

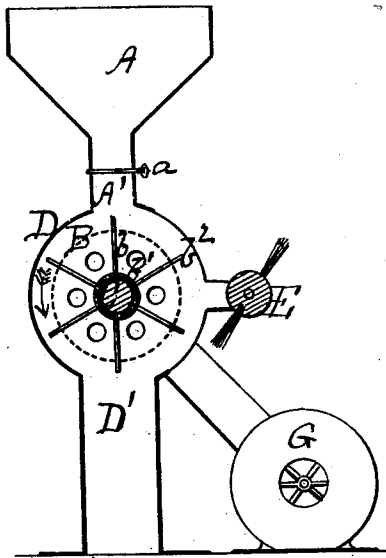

Fig. 2.

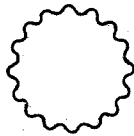

Fig. 3.

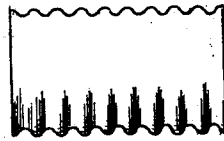

Fig. 4.

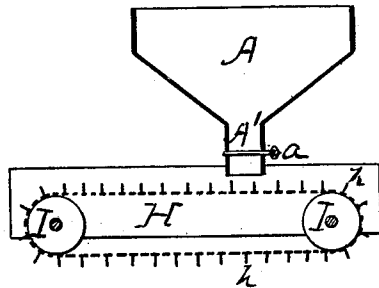
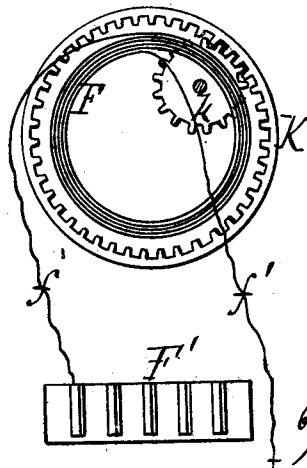

Fig. 5.



Witnesses:
W. B. Masson
D. Plow

Inventor
C. W. Levalley
by H. A. Doubleday
Atty

C. W. LEVALLEY.

Machine for Separating Metal from Grain.
No. 222,191. Patented Dec. 2, 1879.

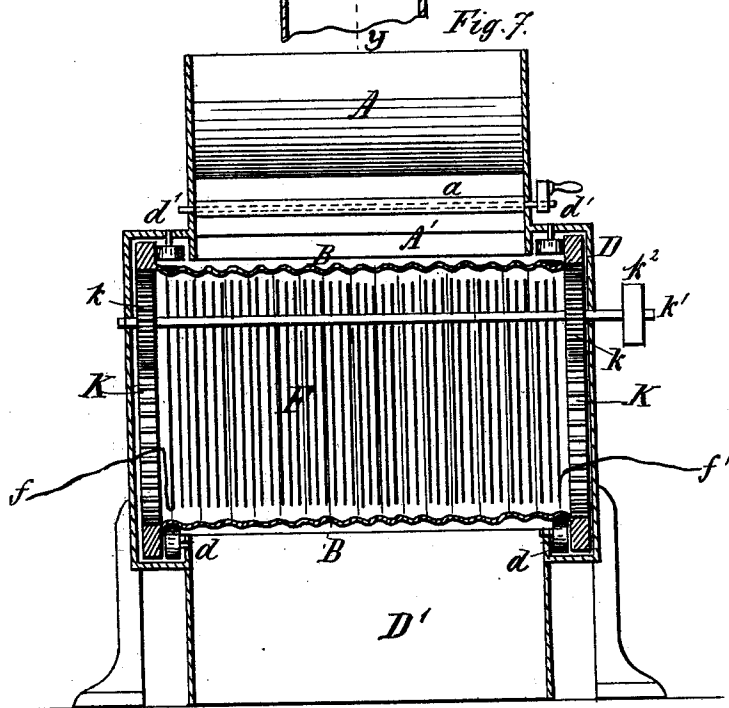
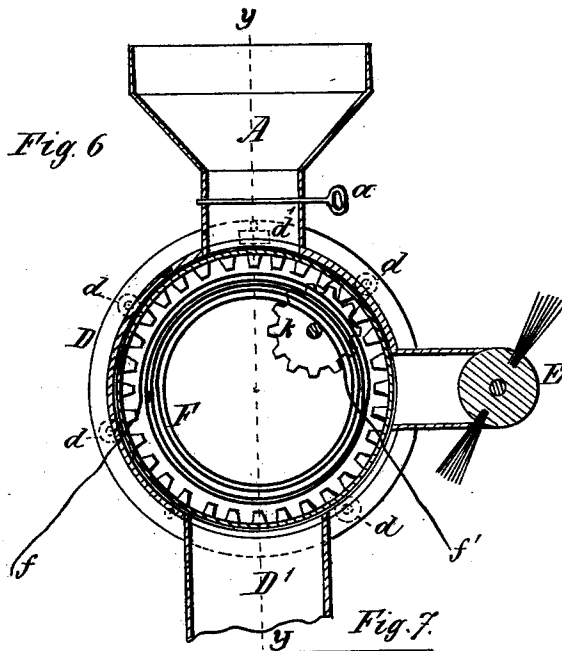

Witnesses.
Henry Orth
J. S. Barker

Inventor
C. W. Levalley
W. A. Doubleday
att'y

UNITED STATES PATENT OFFICE.

CHRISTOPHER W. LEVALLEY, OF ST. PAUL, MINNESOTA.

IMPROVEMENT IN MACHINES FOR SEPARATING METAL FROM GRAIN.

Specification forming part of Letters Patent No. 222,191, dated December 2, 1879; application filed January 4, 1879.

To all whom it may concern:

Be it known that I, CHRISTOPHER W. LEVALLEY, of St. Paul, in the county of Ramsey and State of Minnesota, have invented certain new and useful Improvements in Machines for Separating Metal from Grain; and I do hereby declare that the following is a full, clear, and exact description of the invention, which will enable others skilled in the art to which it appertains to make and use the same, reference being had to the accompanying drawings, and to letters of reference marked thereon, which form a part of this specification.

Many objections are urged against the use of wire for binding grain, and among them is the fact that more or less of the bands are broken into short pieces by the thrasher, which pieces remain in the grain even after the grain is cleaned and prepared for market, and when found in wheat are a source of great annoyance to millers.

The object of this invention is to separate the small pieces of wire from the grain; and to this end it consists in certain means for exposing such grain to contact with a magnet, whereby the bits of metal adhere to the magnet, and are thereby separated from the wheat.

Figure 1 is a vertical cross-section of a machine embodying my invention. Fig. 2 is a detached view of a modification of the magnetic cylinder employed in Fig. 1. Fig. 3 represents another modified form. Fig. 4 is a transverse vertical section of another form of machine embodying the same general principle. Fig. 5 is a sectional view of the machine with the helix arranged inside the cylinder. Fig. 6 is a transverse vertical section of the construction shown in Fig. 7; and Fig. 7 is a vertical longitudinal section taken on line *y y*, Fig. 6.

In the drawings, A represents a hopper, terminating in a spout, A', provided with a gate (indicated at *a*) to regulate the delivery of the grain. B is a cylinder, of iron or steel, the spokes *b* of which connect said cylinder with a short sleeve, *b'*. There is a set of spokes or arms, *b*, and a sleeve, *b'*, at each end of said cylinder. C is a wooden shaft, arranged within the sleeves in such a manner as to support the cylinder and permit its free revolution.

This may be accomplished either by mounting the shaft in suitable bearings or by rotating the cylinder upon the shaft. The outer surface of the cylinder is armed with projecting spurs or pins *b²*, placed at suitable distances apart. These distances may vary according to the kind of grain to be operated upon; but in practice I prefer that they should be about a quarter of an inch apart.

The cylinder is partially inclosed, say upon the ends and one side, by a shell or jacket, D, arranged in close proximity thereto.

D' is a spout leading from the jacket D to, by preference, the hopper of a millstone; but it is evident that the machine may be used in an elevator or elsewhere.

E represents a brush, located opposite the open side of the shell, at such distance from cylinder B that the bristles shall impinge upon its surface when driven by a belt which passes around a sheave or belt-wheel on the brush-shaft and another sheave which is attached to and moves with the cylinder, the relative sizes of these belt-wheels being such, by preference, that the brush is driven at a much higher speed than the cylinder.

It will, of course, be understood that the cylinder-shaft and brush-shaft are mounted in a suitable framing, power being applied to these devices from any suitable prime mover.

F' represents a galvanic battery, one pole of which is connected with one end of a helix within the cylinder B by means of a wire, *f*, attached, by preference, to one of the short sleeves, the other pole of the battery being connected to the opposite end of the cylinder by means of a ground-wire, *f'*, these contacts being frictional ones.

By preference, I highly magnetize the metal of which the cylinder and the pins *b²* are made; but under some circumstances I may employ common soft iron, and magnetize it by means of currents of electricity from the battery F' passing through the helix F.

In operating this machine the grain containing small pieces of iron is fed through the tube A' upon and around the cylinder B, which revolves in the direction indicated by the arrow. As the grain passes around the cylinder the fine pieces of iron adhere to the cylinder and pins, from which they are re-

moved by the action of the brush E, as will be readily understood without further explanation.

It will also be understood that by reason of the casing or jacket D surrounding the magnetic cylinder, the grain is compelled to pass in close proximity to the surface of said cylinder, so as to insure that the entire mass of grain and such particles of metal as may be contained therein shall be brought into close contact with the cylinder.

In Fig. 2 I have shown a modification of the cylinder, in which I employ a cylinder provided with longitudinal ribs or corrugations. In using this construction I propose to employ in combination with it a brush having a motion on a line parallel with the ribs, in order to enter fully into the grooves.

In Fig. 3 the ribs or corrugations run around the cylinder, which latter construction possesses some advantages over that shown in Fig. 2, because a revolving brush like that shown in Fig. 1 can be effectively used to remove the adhering particles of iron.

Under some circumstances I propose to use wire-cloth instead of sheet or other continuous metal for the cylinder B; and I also propose to use, in connection with such wire-cloth cylinder, a fan, G, to produce a current of air through the cylinder, in order to remove therefrom such dust and other material as passes through the wire-cloth.

In Fig. 4 I have shown a similar hopper, A, and spout A', with gate *a*, through which grain is delivered upon an endless apron or belt, H, traveling over driving-rollers I I, which may be actuated by belts or gears from any desired motor.

The endless belt H is made of wire-cloth or other finely-reticulated material, and is, by preference, provided upon its outer face with ribs carrying spurs or points *h*; or, when preferred, said apron may be constructed of leather or other belts carrying cross slats or bars placed so close together as to prevent the grain from falling between them.

The apron may be arranged in either a horizontal or inclined position, and the rollers should be of wood or other non-conducting material, in order to insure that the current of electricity, which is conducted to the machine by wire *f* from battery K, shall traverse the upper line of the apron, and pass thence to the ground by wire *f'*, the contacts of the wires with the apron being frictional.

A bristle brush, like brush E, driven rapidly serves to remove from the apron such particles of iron as have adhered to the magnetic apron or ribs *h* or spurs, these parts being either permanently magnetic or rendered magnetic by the action of the electric currents.

I regard it as being desirable that the cylinder should move in the same direction as the descending grain, because, first, the quantity of grain which must pass through the machine is large, and there would be a liability of the grain sweeping the pieces of wire

from the cylinder in case said cylinder revolved against the moving grain, especially in case the pieces of wire were large in proportion to the magnetic strength of the cylinder; and, further, because in case a corrugated or reticulated cylinder is used, it will require much less power to run the cylinder with the grain. In fact, under a proper construction and adjustment of parts, the weight of the falling grain may be made to drive the mechanism, without the application of other power, in substantially the same manner as water drives a breast water-wheel.

In the construction represented in Figs. 5, 6, and 7, I prefer to support the revolving cylinder substantially as the revolving screen is mounted in patent to J. Allonas, No. 107,994, October 4, 1870, substantially as follows:

K is an internally-toothed ring, to which is attached the corrugated or reticulated cylinder B, said cylinder being mounted within an inclosing shell or casing, D, substantially as is the corresponding cylinder B in Fig. 1.

d d d are supporting-wheels, two or more, attached to the casing D, or other suitable support, in such position that the cylinder B is mounted thereon.

d' d' are guiding-wheels arranged to traverse the inner vertical faces of the flanges or rings K, to prevent undue endwise movement of the cylinder.

k k are spur-pinions mounted on a shaft, *k'*, and meshing with the internally-toothed rings K; and power may be applied to the shaft *k'* by means of a band-wheel, *k²*.

E is a brush operated to sweep the surface of the cylinder B.

F is a helix supported within the cylinder B, and in close proximity thereto.

Two wires, *f f'*, connect the helix F with the two poles of a battery, or with the battery and the ground.

What I desire to claim is—

1. In a machine for removing iron from grain, the combination of the inclosing-shell D, cylinder B, hopper A, and brush E; substantially as set forth.

2. In a machine for removing iron from grain, a reticulated magnetic surface over which the grain passes, substantially as set forth.

3. The combination, in a machine for separating iron from grain, of the following elements, namely: a magnetic surface upon which the grain is delivered, a brush to remove the iron which adheres to the magnetic surface, and a fan to produce a current of air through the machine and remove material which passes through the metallic surface, substantially as set forth.

4. In a machine for separating iron from grain, the combination of a hollow metallic cylinder and a stationary helix, F, with connecting-wires *f f'*, substantially as set forth.

5. In a machine for separating iron from grain, the combination of a metallic cylinder provided with an internally-toothed ring, a helix arranged within the metallic cylinder, and

mechanism whereby said cylinder may be supported and rotated independently of the helix, substantially as set forth.

6. In a machine for separating metal from grain, the combination of a metallic magnetic cylinder, a casing surrounding or partially surrounding said cylinder, a feeding-hopper arranged above the cylinder, and a gate for regulating the feeding of the grain to the cylinder, whereby the grain is held in close prox-

imity to the cylinder while passing over its magnetized surface, substantially as set forth.

In testimony that I claim the foregoing as my own I affix my signature in presence of two witnesses.

CHRISTOPHER W. LEVALLEY.

Witnesses:

H. H. BLISS,
M. P. CALLAN.