

J. B. WEST.
Fluid Pressure Regulator.

No. 215,496.

Patented May 20, 1879.

Fig. 1.

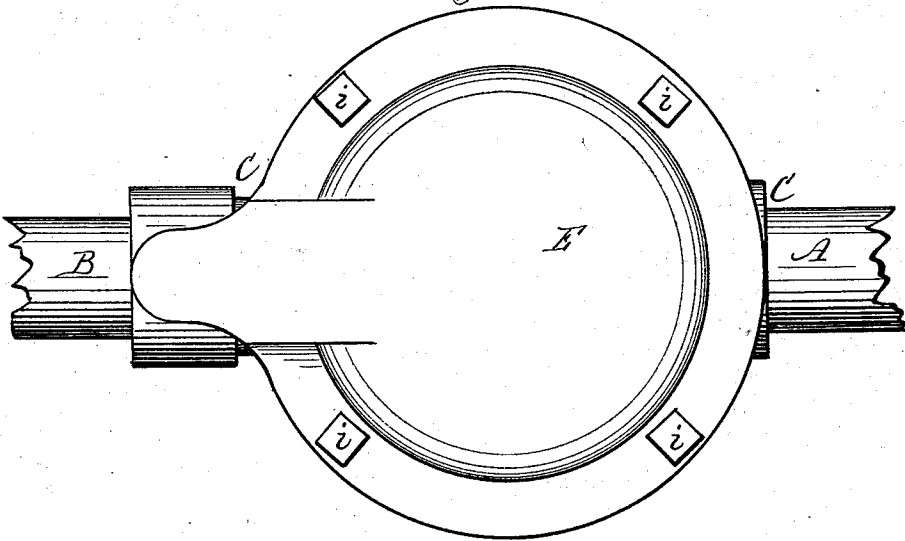
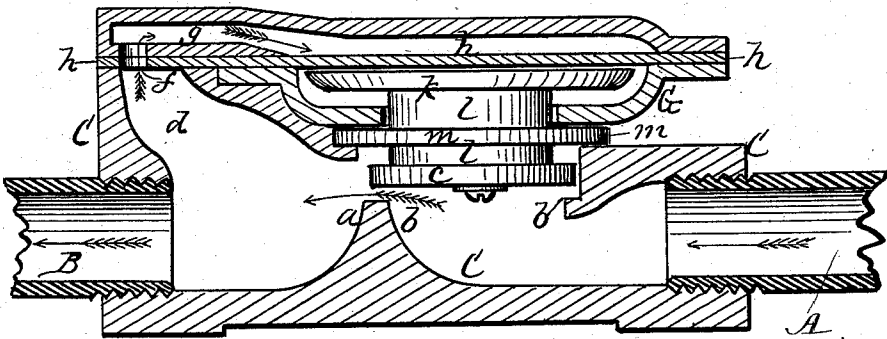

Fig. 2.



Attest.
Jacob Spahn
John C. Burns.

Inventor.
Jonathan B. West
By R. F. Osmond,
Atty.

UNITED STATES PATENT OFFICE.

JONATHAN B. WEST, OF GENESEO, NEW YORK.

IMPROVEMENT IN FLUID-PRESSURE REGULATORS.

Specification forming part of Letters Patent No. 215,496, dated May 20, 1879; application filed October 21, 1878.

To all whom it may concern:

Be it known that I, JONATHAN B. WEST, of Geneseo, in the county of Livingston and State of New York, have invented a certain new and useful Improvement in Water-Pressure Regulators; and I do hereby declare that the following is a full, clear, and exact description of the same, reference being had to the accompanying drawings, in which—

Figure 1 is a plan of the device. Fig. 2 is a longitudinal vertical section.

My improvement relates to means for reducing and regulating the pressure of water in service-pipes in those cases where it is desired to preserve less pressure in said service-pipes than in the mains. Where the pressure in the mains is great and no restriction is interposed between the mains and the service-pipes, the pressure in the latter is sometimes sufficient to burst them, and is also the subject of many other inconveniences and troubles.

To obviate this difficulty, my invention consists of a regulator constructed substantially as hereinafter described.

In the drawings, A represents the induction-pipe, leading to the main; and B, the eduction-pipe, connected with the service-pipes. These pipes connect with the opposite ends of a case or barrel, C, in which is an abutment, *a*, and valve-seat *b*, on which shuts a valve, *c*. When this valve is raised, as shown in Fig. 2, the water has a free passage through from one pipe to the other; but when closed the flow of water is cut off.

d is a passage on the eduction side of the abutment, which leads upward and communicates, by a port, *f*, with a water-passage, *g*, in the hollow cover E. G is a cup-shaped disk, resting on top of the case or barrel C; and *h* is a rubber diaphragm, forming also a packing between the cover E and disk G. These parts are secured together by bolts or screws *i i*.

k is a follower or plate, resting beneath the diaphragm *h* in the cup-disk G, and having a free play up and down, to a limited extent, in said cup. *l* is a stiff metallic stem, depending from the follower, to the lower end of which is attached the valve *c*, while midway is a packing-disk, *m*, which rests between the disk G and the top of the case, as clearly shown in Fig. 2.

The operation is as follows: The water from the induction-pipe, passing beneath the valve and over the abutment, flows through the eduction-pipe in the ordinary way. At the same time a portion goes up through passage *d* and port *f* into passage *g*, above the diaphragm *h*, and exerts a pressure on top of said diaphragm equal to that against the valve below of equal surface; but since the surface of the follower *k* is greater than that of the valve, the over-pressure of the diaphragm on top will force it down, thereby closing the valve upon its seat and stopping the flow. When the pressure on the eduction side is reduced by drawing off the water, the greater pressure on the induction side under the valve will raise the same again and allow the water to pass, and by this means an equilibrium is produced which will preserve the desired difference in pressure on the two opposite sides of the valve. By increasing or lessening the size of the follower *k* relatively to the valve *c* the difference in pressure on the two opposite sides of the valve will be correspondingly changed, and may be gaged as desired.

I am aware that various forms of water-pressure regulators are known, most of which have a diaphragm connected with a weighted lever, by which a stop-cock in the induction-pipe is opened or closed. Such devices are expensive, and occupy much space. My device is simple, cheap, and automatic in action.

If desired, the action may be reversed, the valve moving upward against its seat instead of downward, and the water passing over the valve instead of under it.

A particular advantage results from the use of the diaphragm or packing-disk *m*, which, being clamped between the parts C and G, produces a perfectly water-tight joint, and yet, being flexible, it allows the valve *c* and follower *k* to rise and fall freely, as is necessary in regulating the pressure of the water. It is superior to a stuffing-box, which is liable to leak, and which produces much friction.

What I claim as new is—

1. In a water-pressure regulator, the combination of the valve *c*, the packing-disk *m*, the follower *k*, and the flexible diaphragm *h* with a water-passage, *g*, over said diaphragm, and communicating with the main water-passage

on the eduction side of the valve, as shown and described, and for the purpose specified.

2. In a water-pressure regulator, the combination, with the valve *c* and follower *k*, connected by the stem *l*, of the flexible packing-disk *m*, arranged, as described, so as to allow said valve and follower to play freely up and down, as and for the purpose specified.

In witness whereof I have hereunto signed my name in the presence of two subscribing witnesses.

JONATHAN B. WEST.

Witnesses:

R. F. OSGOOD,
R. E. WHITE.