

(No Model.)

C. T. McCARROLL.
SHEET METAL STOVE.

No. 524,342.

Patented Aug. 14, 1894.

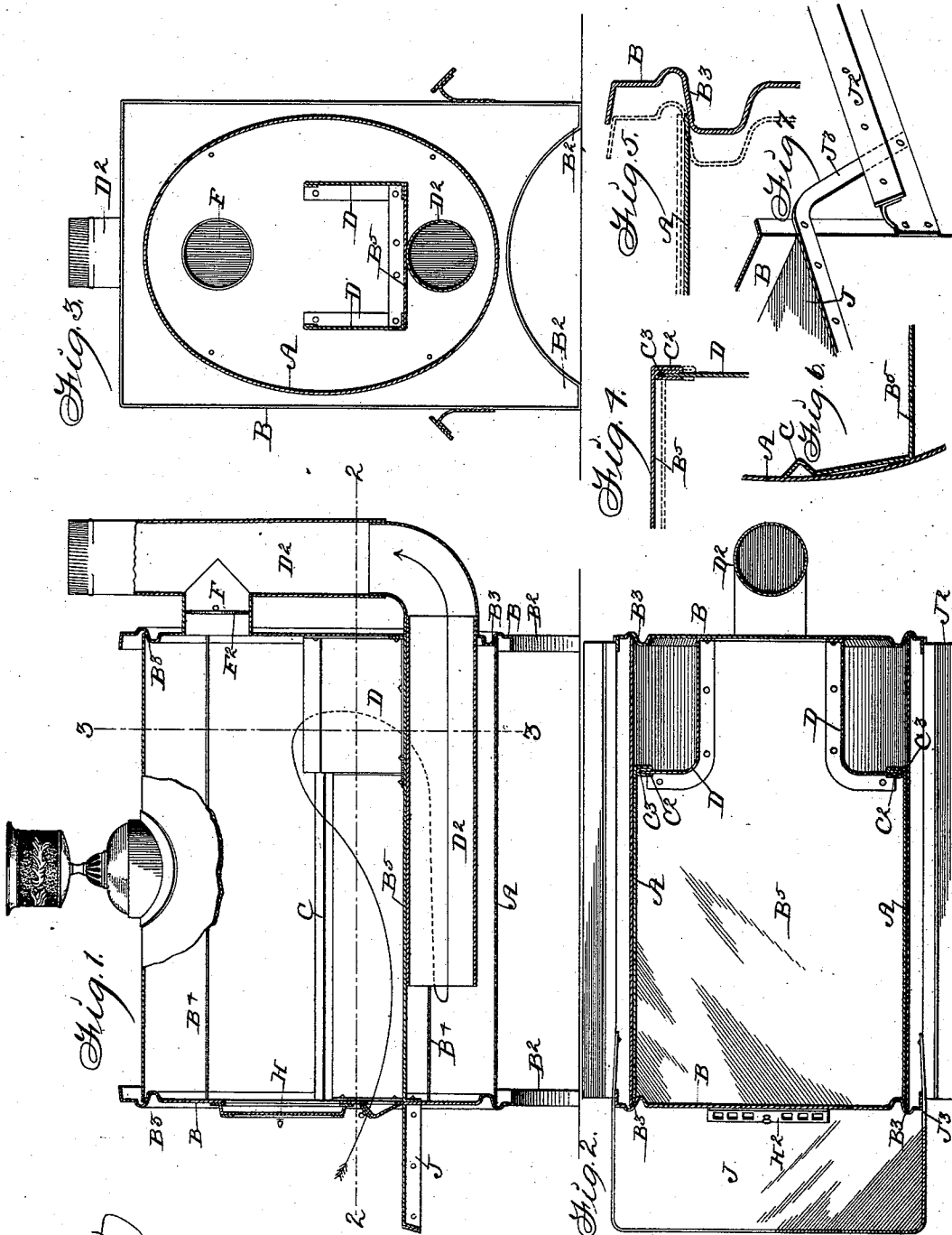

Witnesses:
W. J. Sankey.
R. G. Orwig.

Inventor: Charles T. McCarroll,
By Thomas G. Orwig, J. Ralph Orwig,
Attorneys.

UNITED STATES PATENT OFFICE.

CHARLES T. MCCARROLL, OF OTTUMWA, IOWA.

SHEET-METAL STOVE.

SPECIFICATION forming part of Letters Patent No. 524,342, dated August 14, 1894.

Application filed May 7, 1894. Serial No. 510,259. (No model.)

To all whom it may concern:

Be it known that I, CHARLES T. MCCARROLL, a citizen of the United States of America, residing at Ottumwa, in the county of Wapello and State of Iowa, have invented certain new and useful Improvements in Sheet-Metal Stoves, of which the following is a specification.

My invention relates to a sheet metal stove for which Letters Patent of the United States No. 496,947 were issued to me May 9, 1893, and consists in certain improvements in the same.

The objects of this invention are first to provide means whereby the draft is made strongest near the front of the stove bottom, and further to provide an improved stove bottom by which a dust tight connection is made between a stove bottom and the sides of the stoves without riveting or otherwise securing the same except at the ends of the stove.

My object is further to provide means for producing a dust tight connection between the stove body and ends by means of rods connecting the two ends and without the use of rivets, and further to so arrange and combine the foot rests at the side of the stove, the hearth at the front of the stove and braces for connecting the same that they mutually support and brace each other and the ends of the stove and form a strong, rigid stove body.

To this end my invention consists in the arrangement of the drafts within the stove, the construction of the stove bottom and the manner of attachment with the ends, the formation of the end pieces and the connection of the same with the body and in the construction, arrangement and combination of the foot rests and hearth with the end pieces of the stove as hereinafter set forth, pointed out in my claims and illustrated in the accompanying drawings, in which—

Figure 1 is a vertical longitudinal sectional view of the complete stove in which the line of draft passage is indicated by an arrow. Fig. 2 is a horizontal sectional view through the line 2—2 of Fig. 1. Fig. 3 is a vertical sectional view through the line 3—3 of Fig. 1. Fig. 4 is an enlarged detail view showing the connection between the side pieces of the stove bottom and the post through which the

downward draft passes. Fig. 5 is a like view of the connection between the end and body of the stove. Fig. 6 shows a section of the stove bottom and side and Fig. 7 shows in perspective the braces connecting the hearth, foot rests and end pieces of the stove.

Referring to the accompanying drawings, the reference letter A is used to indicate the stove body, which is oval in transverse section and made of sheet metal.

B indicates the front end piece of the stove formed of a single piece of sheet metal having the integral legs B². Pressed in the sheet metal end by means of dies, is a formation extending in a line that would engage the oval end of the stove body, the essential feature of which is an outwardly beveled shoulder B³ which said end of the stove body is adapted to engage at its inner edge and when drawn tightly toward the end piece will produce a dust tight joint. The formation is made by bending first inwardly and then outwardly beyond the outer surface of the end piece and finally inwardly as clearly shown in Fig. 5. It will be seen that the end piece may readily be placed in position so that the inner edge of the shoulder B³ will engage the edge of the stove body as shown in Fig. 5 and when said parts are tightly drawn together that the edge of the stove body will slide outwardly on said shoulder and produce a tight connection, as indicated by dotted lines in the same figure. Each end piece is provided with a like formation and they are connected by means of four rods B⁴ passed through the end pieces and through the interior of the body part and having nuts on their ends by which the stove ends may be drawn together.

The stove bottom B⁵ is made of a single piece of sheet metal of the same length as the stove body and having the edges bent upwardly to lay parallel with the stove body below the central portion, the top edges of the bottom piece have an inwardly V-shaped groove C formed therein, the top edge of which is adapted to engage the sides of the stove body. Near the rear of the stove the upwardly inclined edges of the side pieces are bent inwardly at C² at right angles to the side pieces and bent to form a groove C³ adapted to admit a piece of sheet metal to be capable of a slight movement therein and at the same

time maintain a tight joint. D indicates sheet metal strips of the same height as the upwardly inclined side pieces and bent inwardly from the sides of the stove and secured to the bottom by means of rivets to form an opening to permit a downward passage of the products of combustion arising from the stove bottom. The forward edges of these pieces are adapted to enter the grooves C³ the rear ends are adapted to be riveted to the end piece of the stove and the bottom thereof to the stove bottom. To attach the bottom to the stove I first place the same in the interior of the stove body, rivet the ends of the bottom to the ends of the stove then press the inclined sides of the stove bottom outwardly into close contact with the stove body and rivet them in position to the ends of the stove the resiliency of the metal serving to hold the edges of the stove bottom in close contact with the sides of the stove.

D indicates the stove pipe, preferably round in transverse section and extended from a point between the stove bottom and the sheet metal stove body near the forward end of the stove rearwardly and then upwardly, a pipe section F communicating therewith and with the interior of the stove body above the stove bottom to produce a direct draft, a damper F² being provided therein by which the draft may be directed downwardly to pass under the stove bottom at the sides of the stove pipe D to the forward end of the stove to enter the forward end of the stove pipe, as clearly indicated by the arrow in Fig. 1.

H indicates a door in the stove front to enter the combustion chamber. H² is a draft door or slide below the door H.

J indicates a hearth made of sheet metal and riveted to the stove front.

J² are foot rests riveted to the end pieces of the stove and extended longitudinally thereof, and J³ are braces made from wrought iron bars riveted to the sides of the hearth and to said foot rests thus securely bracing the hearth and foot rests and strengthening the stove body.

Having thus described my invention, what I claim as new therein, and desire to secure by Letters Patent of the United States therefor, is—

1. An improved sheet metal stove, comprising suitable end pieces and a stove body secured thereto, a sheet metal bottom in said body, a flue extending from a point beneath the said stove bottom at its forward end portion rearwardly and upwardly and flue sections leading from the rear and side portions of the combustion chamber downwardly through the stove bottom for the purposes stated.

2. In a sheet metal stove the following ele-

ments in combination, an oval sheet metal stove body, two sheet metal end portions, having grooves formed therein adapted to be engaged on their outwardly inclined bends by the ends of the stove body and means for clamping said ends to the body portion.

3. In a sheet metal stove the following elements in combination, an oval stove body, two sheet metal ends having formed therein the following bend, along the line of the ends of the stove body, first slightly inwardly then outwardly beyond the surface of the end portions on a bevel, and then inwardly, rods passing through said ends and through the stove body and nuts by which said rods may be drawn tight and the ends secured to the body.

4. In a sheet metal stove having an oval stove body, a stove bottom, comprising a single piece of sheet metal with its side edges bent upwardly and an inward V-shaped bend formed in said edges with the top adapted to engage the side of the stove body and means for riveting the stove bottom proper to the ends of the stove and said upwardly bent portion of the stove bottom thereto, independently of each other for the purposes stated.

5. In a sheet metal stove having an oval stove body, a bottom made of sheet metal having its side edges bent upwardly and a V-shaped bend in the top of said edges, as set forth, two sheet metal flanges connected with the bottom on opposite sides of one of its ends to form downwardly extending draft passages, bends formed in the said upwardly extending portion of the bottom to receive said flanges as shown, and means for independently securing the stove bottom proper, and the upwardly bent portions thereof, to the ends of the stove.

6. In a sheet metal stove having a stove body and ends clamped thereto, a hearth riveted to the stove front, and foot rests extended horizontally at the sides of the stove and connected with the stove ends and braces riveted to the sides of said hearth and to the said foot rests, substantially as and for the purposes stated.

7. An improved sheet metal stove, comprising a horizontal stove body, a supplemental stove bottom above the bottom proper, draft doors in the stove front above the supplemental bottom, draft passages leading downwardly through the rear end of the bottom at the sides of the stove, and a pipe leading from a point near the forward end of the chamber beneath the supplemental bottom, longitudinally of the central portion thereof and then upwardly to the flue, for the purposes stated.

CHARLES T. MCCARROLL.

Witnesses:

W. S. COEN,
VINNIE T. BROWN.