



(51) International Patent Classification:

G02B 6/44 (2006.01) H04B 10/25 (2013.01)
G02B 6/38 (2006.01)

(21) International Application Number:

PCT/US2020/061525

(22) International Filing Date:

20 November 2020 (20.11.2020)

(25) Filing Language:

English

(26) Publication Language:

English

(30) Priority Data:

62/938,037 20 November 2019 (20.11.2019) US

(71) Applicant: COMMScope TECHNOLOGIES LLC
[US/US]; 1100 CommScope Place SE, Hickory, North Carolina 28602 (US).

(72) Inventors: BUDDINGTON, Geoffrey; CommScope, Attention: IP Legal Department, 1100 CommScope Place SE, Hickory, North Carolina 28602 (US). GONZALEZ BLAZQUEZ, Jose-Luis; CommScope, Attention: IP Legal Department, 1100 CommScope Place SE, Hickory, North Carolina 28602 (US). DIEPSTRATEN, Patrick Jacques Ann; CommScope, Attention: IP Legal Department, 1100

CommScope Place SE, Hickory, North Carolina 28602 (US). BIRD, Neil Stewart; CommScope, Attention: IP Legal Department, 1100 CommScope Place SE, Hickory, North Carolina 28602 (US).

(74) Agent: MERCHANT & GOULD P.C. et al.; P.O. Box 2903, Minneapolis, Minnesota 55402-0903 (US).

(81) Designated States (unless otherwise indicated, for every kind of national protection available): AE, AG, AL, AM, AO, AT, AU, AZ, BA, BB, BG, BH, BN, BR, BW, BY, BZ, CA, CH, CL, CN, CO, CR, CU, CZ, DE, DJ, DK, DM, DO, DZ, EC, EE, EG, ES, FI, GB, GD, GE, GH, GM, GT, HN, HR, HU, ID, IL, IN, IR, IS, IT, JO, JP, KE, KG, KH, KN, KP, KR, KW, KZ, LA, LC, LK, LR, LS, LU, LY, MA, MD, ME, MG, MK, MN, MW, MX, MY, MZ, NA, NG, NI, NO, NZ, OM, PA, PE, PG, PH, PL, PT, QA, RO, RS, RU, RW, SA, SC, SD, SE, SG, SK, SL, ST, SV, SY, TH, TJ, TM, TN, TR, TT, TZ, UA, UG, US, UZ, VC, VN, WS, ZA, ZM, ZW.

(84) Designated States (unless otherwise indicated, for every kind of regional protection available): ARIPO (BW, GH, GM, KE, LR, LS, MW, MZ, NA, RW, SD, SL, ST, SZ, TZ, UG, ZM, ZW), Eurasian (AM, AZ, BY, KG, KZ, RU, TJ, TM), European (AL, AT, BE, BG, CH, CY, CZ, DE, DK, EE, ES, FI, FR, GB, GR, HR, HU, IE, IS, IT, LT, LU, LV,

(54) Title: SYSTEM AND DEPLOYMENT METHOD FOR A FIBER OPTIC CONNECTOR ASSEMBLY HAVING A BLOWABLE SECTION AND A NON-BLOWABLE SECTION

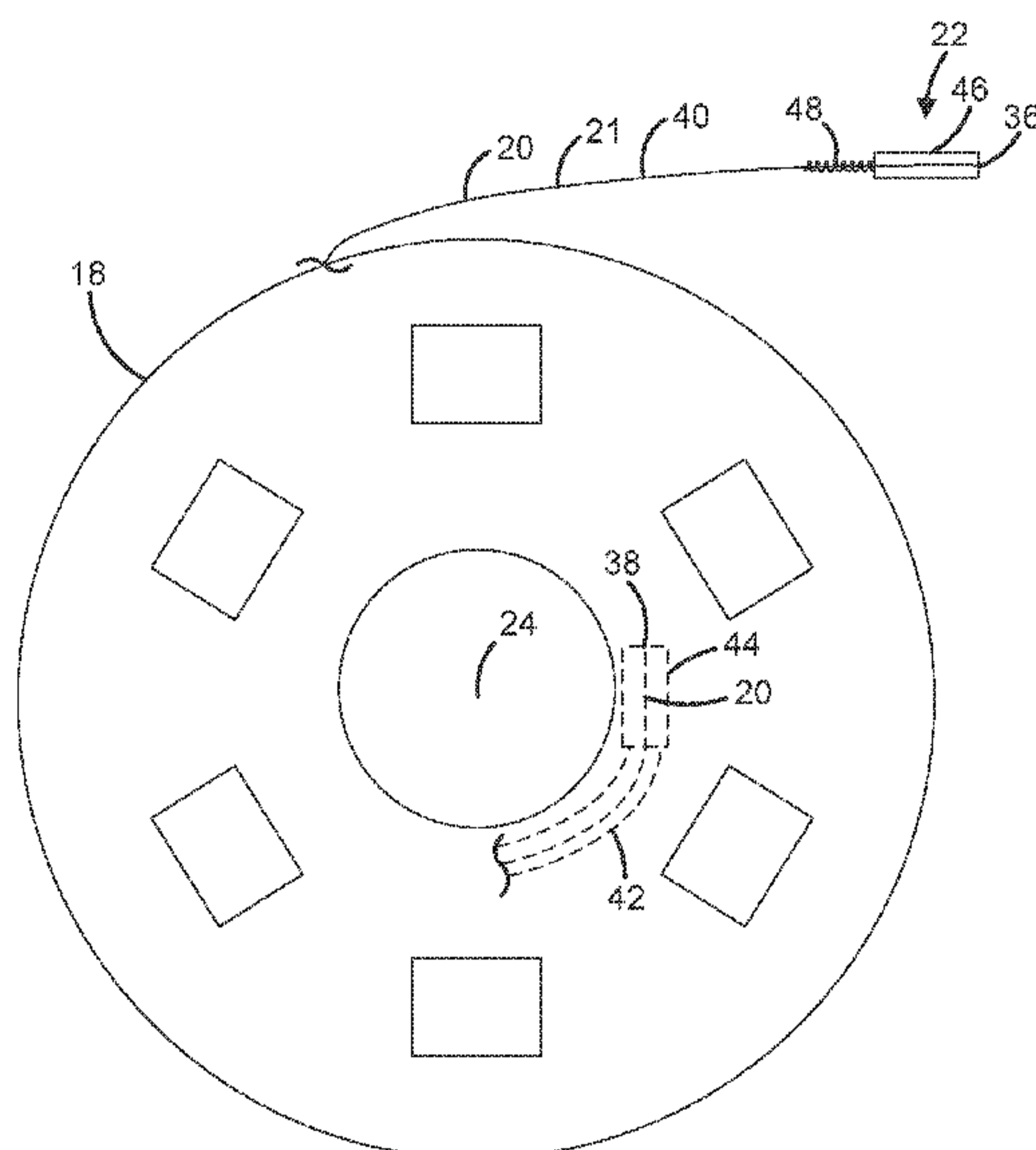

FIG. 2

(57) Abstract: Systems, assemblies and methods for deploying an optical fiber through a duct to a customer premises. A blowable section of the optical fiber is blown through the duct. A non-blowable section of the optical fiber is coupled to a trail end of the duct. The non-blowable section can be terminated with a hardened or ruggedized connector. The optical fiber, including both the blowable and non-blowable sections, can be wound around a spool for easy payout of the blowable section.



MC, MK, MT, NL, NO, PL, PT, RO, RS, SE, SI, SK, SM,
TR), OAPI (BF, BJ, CF, CG, CI, CM, GA, GN, GQ, GW,
KM, ML, MR, NE, SN, TD, TG).

Published:

- *with international search report (Art. 21(3))*
- *before the expiration of the time limit for amending the claims and to be republished in the event of receipt of amendments (Rule 48.2(h))*

fibers up to 1500 fibers. The smaller fiber access terminals may more typically house up to 8 or 12 fibers. The fiber distribution cables between the fiber distribution terminal and the fiber access terminal may have these eight to twelve fibers bundled together in a single multi-strand cable. Within the fiber access terminal, these multiple strands are broken out
5 of the multistrand cable so that each fiber may be directed to an individual customer.

A fiber access terminal is often placed in a hand hole below grade near the customer location, attached to, or positioned within a cavity of, a telephone pole near the customer location, or attached to an aerially suspended power line or other cable near the customer location. Examples of fiber access terminals are described in U.S. Patent No.
10 7,292,763, the contents of which are hereby incorporated by reference in their entirety.

Drop cables terminated at the supply side with ruggedized connectors are connected to the fiber access terminal and routed to the customer location(s). Since the fiber access terminal can be exposed to the elements outdoors, the drop cables and their supply side connectors are ruggedized to protect them from external loads. Examples of
15 ruggedized connectors are described, for example, in International Patent Publication No. WO 2009/076364, the contents of which are fully incorporated herein by reference in their entirety.

Currently, a variety of techniques are available for pulling, pushing or blowing a cable through a duct. For example, United Kingdom Patent GB 2559489B is
20 incorporated herein in its entirety and describes blowing a lightweight length of fiber through a duct.

However, ruggedized cables can be too heavy and/or too thick to be blown or otherwise deployed through a duct between a fiber access terminal and a customer location.

25

Summary

In general terms, the present disclosure is directed to optical fiber assemblies and associated methods. The optical fiber assemblies include a blowable fiber section that can be blown through a duct, and a non-blowable fiber section that can be connected, e.g., to a hardened port of a terminal or closure.

30

According to certain aspects of the present disclosure, a blown fiber assembly comprises: a spool; an optical drop line including a blowable fiber section adapted to be blown through a fiber duct and a sheathed fiber section, the sheathed fiber section having an outer dimension at least 2 times as large as an outer dimension of the

blowable fiber section, the blowable fiber section being at least 25 times as long as the sheathed fiber section, the blowable fiber section and the sheathed fiber section being coiled about the spool with the blowable fiber section being coiled about the spool farther from a rotation axis of the spool than the sheathed fiber section; a partial connector factory
5 terminated at an end of the blowable fiber section; and a hardened fiber optic connector factory terminated at an end of the sheathed fiber section.

According to further aspects of the present disclosure, a blown fiber assembly comprises: a spool; an optical drop line including a blowable fiber section adapted to be blown through a fiber duct and a sheathed fiber section, the blowable fiber
10 section being at least 25 times as long as the sheathed fiber section, the blowable fiber section and the sheathed fiber section being coiled about the spool with the blowable fiber section being coiled about the spool farther from a rotation axis of the spool than the sheathed fiber section; a partial connector factory terminated at an end of the blowable fiber section; and a hardened fiber optic connector factory terminated at an end of the
15 sheathed fiber section, the hardened fiber optic connector having an outer dimension that is at least 8 times as large as an outer dimension of the blowable fiber section.

According to further aspects of the present disclosure, a fiber optic connector system for deploying optical fiber through a duct defined by a longitudinal duct axis and having a largest duct interior dimension perpendicular to the longitudinal duct
20 axis, comprises: an optical fiber defined by a longitudinal fiber axis extending between a trail end and a lead end of the optical fiber, the optical fiber including: a first axial section having a longitudinal length of at least 1.0 meters and extending axially from the lead end of the optical fiber toward the trail end of the optical fiber, the first axial section being surrounded by a first outermost protective layer at a trail end of the first axial section, the
25 first outermost protective layer having a largest dimension perpendicular to the longitudinal fiber axis that is less than the largest duct interior dimension; and a second axial section having a longitudinal length of at least 0.1 meters and extending from the trail end of the optical fiber towards the lead end of the optical fiber, the second axial section being pre-terminated at a fiber optic connector positioned at the trail end of the
30 optical fiber, the second axial section being surrounded by a sheath defining a second outermost protective layer extending axially from the connector to a lead end of the second axial section, the second outermost protective layer having a largest dimension perpendicular to the longitudinal fiber axis that is greater than or equal to the largest interior duct dimension.

According to further aspects of the present disclosure, a fiber optic connector system for deploying optical fiber through a duct defining a longitudinal duct axis and having a largest duct interior dimension perpendicular to the longitudinal axis, comprises: an optical fiber defining a longitudinal fiber axis extending between a trail end and a lead end of the optical fiber, the optical fiber including: a first axial section having a longitudinal length of at least 1.0 meters and extending axially from the lead end of the optical fiber towards the trail end of the optical fiber, the first axial section being surrounded by a first outermost protective layer at a trail end of the first axial section, the first outermost protective layer having a largest dimension perpendicular to the longitudinal fiber axis that is less than the largest duct interior dimension; and a second axial section extending from the trail end of the optical fiber towards the lead end of the optical fiber, the second axial section being pre-terminated at a fiber optic connector positioned at the trail end of the optical fiber, the connector having a largest outer dimension perpendicular to the longitudinal fiber axis that is greater than or equal to the largest duct interior dimension.

According to further aspects of the present disclosure, a fiber optic connector system, comprises: a spool; and an optical fiber defined by a longitudinal fiber axis extending between a trail end and a lead end of the optical fiber, the optical fiber being spooled about the spool and including: a first axial section having a longitudinal length of at least 1.0 meters and extending axially from the lead end of the optical fiber toward the trail end of the optical fiber, the first axial section being configured to be blown through a duct having a predefined size; and a second axial section having a longitudinal length of at least 0.1 meters and extending from the trail end of the optical fiber towards the lead end of the optical fiber, the second axial section being pre-terminated at a fiber optic connector positioned at the trail end of the optical fiber, the second axial section not being configured to be blown through the duct, wherein the first and second axial sections are wound about the spool such that the spool is configured to payout the first axial section before the second axial section.

According to further aspects of the present disclosure, a method comprises: providing a duct having a length extending from a duct trail end to a duct lead end along a longitudinal duct axis; providing an optical fiber defined by a longitudinal fiber axis extending between a fiber trail end and a fiber lead end of the optical fiber, the optical fiber including a first axial section having a longitudinal length of at least 1.0 meters and extending axially from the fiber lead end toward the fiber trail end, and a second axial

section having a longitudinal length of at least 0.1 meters and extending from the first axial section towards the fiber trail end, the entire longitudinal length of the second axial section having a largest dimension perpendicular to the longitudinal fiber axis that exceeds a largest inner dimension of the duct perpendicular to the longitudinal duct axis; advancing the lead end of the optical fiber through the entire length of the duct; and subsequent to the advancing, fastening a lead end of the second axial section to the duct trail end.

A variety of additional aspects will be set forth in the description that follows. The aspects relate to individual features and to combinations of features. It is to be understood that both the foregoing general description and the following detailed description are exemplary and explanatory only and are not restrictive of the broad inventive concepts upon which the examples disclosed herein are based.

Brief Description of the Drawings

FIG. 1 is a schematic view of components of a fiber optic connector system in accordance with the present disclosure.

FIG. 2 is a schematic view of an example embodiment of a spool and portions of an example fiber optic connector assembly according to the present disclosure.

FIG. 3 is a schematic view of an example fiber optic connector assembly in accordance with the present disclosure.

FIG. 4 is a schematic view of a further example fiber optic connector assembly in accordance with the present disclosure.

FIG. 5 is an example ruggedized (or hardened) connector that can terminate the trail end of the optical fiber of the fiber optic connector assemblies of FIGS. 1-4.

FIG. 6 is a perspective view of an example embodiment of the fiber access terminal of the system of FIG. 1.

FIG. 7 is a perspective view of an example embodiment of the coupler of the fiber optic connector assembly of FIG. 4.

FIG. 8 is an example process flow for installing a fiber optic connector assembly in accordance with the present disclosure.

Detailed Description

Various embodiments will be described in detail with reference to the drawings, wherein like reference numerals represent like parts and assemblies throughout the several views. Reference to various embodiments does not limit the scope of the

claims attached hereto. Additionally, any examples set forth in this specification are not intended to be limiting and merely set forth some of the many possible embodiments for the appended claims.

Referring to FIG. 1, a customer building 2 (e.g., a residence or business) receives and transmits data signals via a telecommunications system in accordance with the present disclosure. The building 2 includes equipment 4, such as a wall-mounted box at which one or more optical fibers of the telecommunications network is operatively connected. Excess fiber slack can be stored in one or more loops at the wall-mounted box or another fiber storage structure at the building 2. A duct 6 is buried below the ground 8. The duct 6 provides a passage for one or more optical fibers extending between a hand hole 10 and the building 2. The number of fibers supported by the duct 6 can depend on the number of different customers at the building 2 and/or the amount of bandwidth required at the building 2. Multiple, separate, ducts can be provided for multiple customers or, alternatively, a single duct can define multiple channels, where each channel receives an individual fiber or group of fibers (e.g., two fibers).

A fiber management terminal 12, such as a fiber access terminal, is positioned within the hand hole 10. A feeder cable 14 is routed underground (or from above ground) to the terminal 12. Fibers from the feeder cable 14 are managed within the terminal 12 and connected to fibers that are routed to the customer location, e.g., via the duct 6. The terminal 12 includes ruggedized ports 16 adapted to sealingly receive and secure ruggedized connectors that terminate optical fibers that are routed to the customer location. The ruggedized ports 16 can be adapted to receive the connectors in a twist-to-lock fashion (e.g., via complementary threaded portions at the port and the connector, complementary bayonet lock components, etc.). A sealing element (e.g., an O-ring or gasket positioned at the port and abutting the connector can minimize egress of contaminants into the closure via the port when the connector is mated at the port. When not in use, the ports can be sealingly plugged.

In alternative use applications, one or more of the feeder cable 14, the terminal 12 and/or the duct 6 can be positioned above ground. For example, the terminal 12 can be mounted to an aerially suspended cable or to a telephone pole, or positioned within a cavity within a telephone pole.

An optical drop line 21 including an optical fiber 20 is wound around a spool 18. A single optical fiber will be described herein; however, it should be appreciated

that the same principles can apply to a multi-fiber arrangement that is wound around the spool 18.

The optical fiber 20 is used to operatively connect the terminal 12 and the equipment 4. The optical fiber 20 includes a blowable fiber section and a non-blowable fiber section, both of which portions are initially wound around the spool 18. When wound around the spool, the non-blowable fiber section is generally positioned radially closer to the rotation axis 24 (extending into the page in FIG. 1) defined by the spool as compared with the blowable fiber section, which is generally positioned radially farther from the rotation axis 24. Thus, when unwinding the optical fiber 20 from the spool, the blowable section is paid out before the non-blowable section.

The blowable section is terminated at a lead end of the optical fiber 20 with a partial fiber optic connector 22, such as a ferrule and a spring. The trail end of the optical fiber 20 is terminated with a ruggedized connector, which coincides with the trail end of the non-blowable section of the optical fiber. The optical fiber 20 defines a longitudinal axis extending from the lead end of the optical fiber to the trail end of the optical fiber. These terminations, along with winding the optical drop line 21 about the spool can be performed at the factory, rather than in the field.

To blow the blowable section of the optical fiber 20 through the duct 6 from the trail end 30 of the duct 6 to the lead end 32 of the duct 6 along the longitudinal axis 33 defined by the duct, a blowing machine 26 can be used, which can be mounted to the trail end 30 of the duct and generates a jet of air or another fluid to propel the blowable section of the optical fiber 20 such that the lead end of the optical fiber 20 extends beyond the lead end 32 of the duct 6 and can be connected and/or stored at or near the equipment 4. As the blowable section of the optical fiber 20 is blown along the duct 6, the blowable section is paid out from the spool as the spool 18 rotates about the rotation axis 24.

The payout continues until the entire blowable section is unwound from the spool 18. At this point, the non-blowable section can be unwound (e.g., manually) from the spool 18, and a lead end of the non-blowable portion can be secured to the trail end 30 of the duct, optionally with a gas block to seal off the trail end of the duct. In addition, the ruggedized connector can be operatively connected to the terminal 12 at one of the ruggedized ports 16. On the customer side, the partial connector can be completed, e.g., by installing a connector body onto the ferrule, and the completed connector can be operatively installed at the equipment 4 to provide network link to the building 2. Excess

slack of the blowable section that has cleared the lead end 32 of the duct 6 can be looped at a storage location at the building 2.

The process can be repeated for as many fibers as needed to be routed to the building 2 and/or other buildings in the vicinity of the building 2 that are served by the same man hole and/or the same terminal 12, provided that such fibers can be accommodated by the terminal 12 (e.g., there are sufficient ports 16 at the terminal 12), and the associated ductwork (e.g., there are sufficient ducts and discrete fiber channels within ducts).

The duct defines a largest internal dimension D1 perpendicular to the longitudinal axis 33. In some examples, the duct defines a circular cross-section, with the internal dimension D1 being a diameter of that cross-section.

Referring to FIG. 2, which schematically illustrates additional features of the spool 18 of FIG. 1, the optical fiber is axially continuous along the longitudinal axis defined by the fiber between a lead end 36 of the optical fiber and a trail end 38 of the optical fiber. The lead end 36 is terminated at the partial connector 22, which consists of a ferrule 46 and a spring 48 for axially biasing the ferrule once the remainder of the full connector is assembled about the partial connector 22. The blowable portion 40 of the optical fiber 20 extends from the partial connector 22 towards the trail end 38 of the optical fiber 20.

The trail end 38 of the optical fiber 20 is terminated at a ruggedized connector 38 which extends from the non-blowable section 42 of the optical fiber 42. The non-blowable section 42 and the ruggedized connector 38 are positioned closer to the rotation axis 24 than the blowable section 40 prior to payout of the optical fiber 20.

In some examples, one or more sections of fiber are spliced together to form the continuous optical fiber 20. Such splice(s) can be formed, for example, in the factory, allowing for quick installation and payout from the spool 18 in the field. Such splices can be positioned, e.g., in the ruggedized connector 38 and/or within the partial connector 22, or adjacent thereto if the ruggedized connector 38 and/or partial connector 22 is formed with a stub fiber. One or more splices can alternatively or additionally be provided at one or more intermediate positions between the ruggedized connector and the partial connector. In some examples, the optical fiber 20 includes no splices.

Although the optical fiber 20 will be described herein as including a blowable section (or portion) and a non-blowable section (or portion), the optical fiber may, in addition, or alternatively, define other duct-advancement characteristics. For

example, the section 40 can be pullable through a given duct, while the section 42 is not pullable through the same duct. In another example, the section 40 can be pushable through a given duct, while the section 42 is not pushable through the same duct.

5 The spool 18 allows for deploying a relatively longer length, lighter weight (per longitudinal unit length), and thinner section of a fiber in one direction (e.g., towards a customer location) and deploying a relatively shorter length, heavier weight (per longitudinal unit length) and thicker section of a fiber in another direction, e.g., to connect the ruggedized connector to a fiber access terminal.

10 Referring to FIG. 3, an example optical fiber 20 for spooling around a spool in accordance with the present disclosure is depicted schematically. The optical fiber 20 extends along a longitudinal fiber axis 60 defined by the fiber 20 from a lead end 36 to a trail end 38. The lead end 36 is pre-terminated with a partial optical connector 22 that has sufficiently small transverse profile to be blown through a given duct. The partial connector 22 can include, e.g., a ferrule alone, or a ferrule and a spring. The ferrule can
15 include a ferrule hub.

The trail end 38 is pre-terminated with a fully operational ruggedized fiber optic connector 44. The ruggedized connector 44 can include a twist-to-lock feature, such as screw threads and/or a bayonet style locking component to secure the connector 44 in a port of a fiber access terminal. The connector 44 can also include a sealing element, such
20 as a gasket or O-ring for sealing off the port when the connector is connected thereto. Any desirable form factor can be provided for the connector, such as SC or LC form factors. Likewise, the partial connector 22 can be fully assembled into any desired form factor of connector, such as SC or LC form factors, using the appropriate connector housing and other connector components.

25 An example ruggedized connector 70 that can represent the connector 44 is shown in FIG. 6. The connector 70 is secured to a sheathed section 68 (FIGS. 3, 6) of the optical fiber 20. The connector 70 includes a connector housing 77 supporting a ferrule 79 that terminates the fiber 20 at the trail end 38. The housing 77 is ruggedized with a coupling nut 75, screw threads 71 and a sealing element (e.g., a gasket) 73. The connector
30 70 can be sealingly installed in a ruggedized port of a fiber access terminal, such as the port 82 of the example terminal 80 shown in FIG. 5. The terminal 80 is an example embodiment of the terminal 12 of FIG. 1. The terminal 80 includes a main cable port 84 that can sealingly receive (e.g., with a cable grommet) a feeder cable, such as the feeder cable 14 (FIG. 1). Fibers of the feeder cable are managed within the closure volume

defined by the terminal 80 and optically connected using connectors at an internal side of the ports 82 to the ruggedized connectors at external sides of the ports 82.

Additional non-limiting examples of ruggedized connectors that can be used for the connector 44 include the DLX style connectors by CommScope ® (Hickory, North Carolina), the OPTITAP ® connectors by Corning Incorporated (Corning, New York), and the FASTCONNECT connectors by Huawei Technologies Co., Ltd. (Shenzhen, China).

Referring again to FIG. 3, the blowable section or portion 62 of the fiber 20 has a longitudinal length L1 and the non-blowable section or portion 64 has a longitudinal length L2. In at least some examples, the length L1 is significantly longer than the length L2, since the blowing operation required to deploy the lead end of the fiber to a customer premises via a duct generally covers a much longer routing distance than connecting the trail end of the fiber to a ruggedized terminal. In some examples the length L1 is at least 10 times, at least 15 times, at least 20 times, at least 25 times, at least 30 times, at least 35 times, at least 40 times, at least 45 times, at least 50 times, or greater, than the length L2.

In some examples, L1 is in a range from about 10 meters to about 1,000 meters, or in a range from about 50 meters to about 800 meters. In some examples, L1 is less than or equal to about 700 meters. In some examples, L2 is at least 0.5 meters. In some examples, L2 is in a range from about 0.5 meters to about 5 meters. In some examples, L2 is in a range from about 1 meter to about 3 meters.

The blowable portion 62 includes an outer protective layer 66 that protects the bare fiber within. The outer protective layer 66 can be, e.g., a coating layer or a cladding layer. In at least some examples, no strengthening element, such as aramid yarn, is placed between the bare fiber and the outer protective layer 66, allowing the blowable portion 62 to remain relatively lightweight and have a relatively small cross-sectional profile to promote its blowability. The blowable portion 62 has a largest outer dimension D2 perpendicular to the longitudinal axis 60.

The non-blowable portion 64 includes an outer sheath 68 that receives the fiber 20. The sheath 68 can be, e.g., a protective tube or a cable jacket. Optionally, the non-blowable portion 64 can be ruggedized with a reinforcing layer or strength element 86, such as aramid yarn, positioned radially between the fiber 20 and the sheath 68. The strength element 86 and the sheath 68 can add durability and reinforcement against bending, and the sheath 68 can protect against egress of contaminants. The connector 44

can be sealingly secured to a trail end of the sheath 68. The sheath 68 includes a largest outer dimension D3.

The dimension D2 is smaller than the dimension D3. The dimension D2 is sufficiently small to allow the blowable section 62 to be blown through a given duct of predefined internal dimensions. In some examples, the dimension D3 is larger than the largest internal dimension of the duct (or duct channel) through which the blowable section 62 is to be blown. In some examples, the dimension D3 is at least 1.5 times, at least 2 times, at least 3 times, at least 4 times, at least 5 times, at least 6 times, at least 7 times, at least 8 times, at least 9 times, or at least 10 times the dimension D2. In some examples, the dimension D3 is least 1.05 times, at least 1.1 times, at least 1.2 times, at least 1.3 times, at least 1.4 times, at least 1.5 times, at least 1.6 times, at least 1.7 times, at least 1.8 times, at least 1.9 times, or at least 2.0 times the dimension D1 (FIG. 1). In some examples, the dimension D1 (FIG. 1) is least 1.05 times, at least 1.1 times, at least 1.5 times, at least 2 times, at least 3 times, at least 4 times, or at least 5 times the dimension D2. In some examples, the dimension D1 is in a range from about 3 millimeters to about 5 millimeters. In some examples, the dimension D2 is in a range from about 0.7 millimeters to about 1.5 millimeters. In some examples, the dimension D3 is in a range from about 4 millimeters to about 10 millimeters. Dimensions outside of these ranges are also possible. In some examples, the dimension D1 is in a range from about 3.5 millimeters to about 4.0 millimeters, the dimension D2 is about 1.1 millimeters, and the dimension D3 is about 5.0 millimeters.

The ruggedized connector 44 has a dimension D4 (FIG. 3) perpendicular to the longitudinal axis 60. The dimension D4 is larger than the dimension D3. The dimension D4 is also larger than the dimension D1 (FIG. 1). In some examples, the dimension D4 is at least 7 millimeters, or at least 8 millimeters, or at least 9 millimeters, or at least 10 millimeters, or at least 11 millimeters, or at least 12 millimeters, or at least 13 millimeters, or at least 14 millimeters, or at least 15 millimeters, or greater. In some examples, the dimension D4 is least 1.05 times, at least 1.1 times, at least 1.2 times, at least 1.3 times, at least 1.4 times, at least 1.5 times, at least 1.6 times, at least 1.7 times, at least 1.8 times, at least 1.9 times, at least 2.0 times, at least 2.5 times, or at least 3.0 times the dimension D1 (FIG. 1).

Referring to FIG. 4, a modified version of the fiber 20 is shown. In this example, the fiber 20 includes a splice 90. The splice can be, e.g., a mechanical splice or a fusion splice. Additional splices can also be performed along the length of the optical fiber

20 including, optionally, with stub fibers pre-terminated at the connector 44 and/or partial connector 22. All splice(s) are completed prior to winding the fiber 20 on the spool 18 (FIG. 1).

5 Still referring to FIG. 4, a coupler 92 is positioned around the fiber 20. The coupler 92 can be installed prior to winding the fiber 20 on the spool or after deployment of the blowable section of the fiber 20 to the customer premises. The coupler 92 has a lead end 94 and a trail end 96. A portion of the coupler adjacent its lead end 94 is adapted to receive, and/or be received by, the trail end 30 of the duct 6 (FIG. 1), and a portion of the coupler 92 adjacent its trail end 96 receives (and/or is received by) a lead end portion of the non-blowable section 64. Once the blowable section of the fiber has been deployed, 10 the coupler 92 can be secured at both lead and front ends to the duct 6 and the sheath 68 of the non-blowable portion 64, respectively, to thereby secure the fiber connector assembly to the duct and minimize undesirable shifting of the fiber relative to the duct. Optionally, the coupler 92 is fitted with a gas block adapted to plug the trail end 30 of the duct 6 and 15 minimize egress of gas or other contaminants into the duct 6. Optionally, the coupler 92 includes one or more blades that cut into the sheath 68 when securing the coupler 92 to the sheath. In some examples in which the coupler 92 includes a gas block, the coupler 92 is installed on the fiber 20 prior to winding the fiber 20 on the spool. An example embodiment of the coupler 92 is shown in FIG. 7. The coupler 100 of FIG. 7 is provided 20 by Emtelle UK Limited (United Kingdom). The coupler 100 extends between a trail end 102 and a lead end 104. The trail end 102 defines an opening adapted to receive the sheath 68 (FIG. 4). The lead end 104 is adapted to fit about the trail end 30 of the duct 6 (FIG. 1). An actuator 106 can be operated to clamp the sheath 68 and engage the gas block with which the coupler 100 is fitted at the trail end 30 of the duct to seal off the duct about the 25 fiber 20 at the trail end of the duct.

Referring now to FIG. 8, an example process flow 200 for installing a fiber optic connector assembly in accordance with the present disclosure will be described.

In an initial step 202 of the process 200, a trail end of the optical fiber is terminated with a complete, ruggedized fiber optic connector. In a step 204, the lead end 30 of the optical fiber is terminated with a partial fiber optic connector. The steps 202 and 204 can be optionally performed in the reverse order. In a step 206, following the steps 202 and 204, the fiber is wound about a spool, beginning from the trail end, such that the lead end is farther from the spool's rotation axis than the trail end. In a step 208, following the step 206, a blowable section of the optical fiber extending from the lead end is blown,

e.g., with a blowing machine, through a duct causing the blowable portion of the fiber to payout from the spool. In a step 210, following the step 208, the non-blowable section of the fiber including the trail end is removed (e.g., unwound) from the spool. In a step 212, following the step 210, an outer protective sheath of the non-blowable portion is coupled to the trail end of the duct, e.g., using a tube-to-tube coupler. In an optional step 214, the trail end of the duct is plugged with a gas block. Optionally, the gas block is a component of the tube-to-tube coupler. In a step 216, the partial fiber optic connector is completed at least by installing a connector housing, and the completed connector can be connected to telecommunications equipment at a customer premises. Optionally, slack loops of the blowable section that has exited the duct can be formed and stored at a fiber storage location at the customer premises. In a step 218, the ruggedized fiber optic connector is connected to a fiber access terminal, e.g., within the cavity of a hand hole. The steps 212, 214, 216 and 218 can be performed in any order following the step 210. It should be appreciated that not all steps in the process need to be performed and/or additional steps can be included.

Although the subject matter has been described in language specific to structural features and/or methodological acts, it is to be understood that the subject matter defined in the appended claims is not necessarily limited to the specific features or acts described above. Rather, the specific features and acts described above are disclosed as example forms of implementing the claims.

What is claimed is:

1. A blown fiber assembly, comprising:

a spool;

an optical drop line including a blowable fiber section adapted to be blown through a fiber duct and a sheathed fiber section, the sheathed fiber section having an outer dimension at least 2 times as large as an outer dimension of the blowable fiber section, the blowable fiber section being at least 25 times as long as the sheathed fiber section, the blowable fiber section and the sheathed fiber section being coiled about the spool with the blowable fiber section being coiled about the spool farther from a rotation axis of the spool than the sheathed fiber section;

a partial connector factory terminated at an end of the blowable fiber section; and

a hardened fiber optic connector factory terminated at an end of the sheathed fiber section.

2. A blown fiber assembly, comprising:

a spool;

an optical drop line including a blowable fiber section adapted to be blown through a fiber duct and a sheathed fiber section, the blowable fiber section being at least 25 times as long as the sheathed fiber section, the blowable fiber section and the sheathed fiber section being coiled about the spool with the blowable fiber section being coiled about the spool farther from a rotation axis of the spool than the sheathed fiber section;

a partial connector factory terminated at an end of the blowable fiber section; and

a hardened fiber optic connector factory terminated at an end of the sheathed fiber section, the hardened fiber optic connector having an outer dimension that is at least 8 times as large as an outer dimension of the blowable fiber section.

3. The blown fiber assembly of claim 1 or 2, wherein the sheathed fiber section includes an outer layer defined by a cable jacket, and also includes an aramid reinforcing layer positioned within the cable jacket.

4. The blown fiber assembly of claim 1 or 2, wherein the sheathed fiber section includes an outer layer defined by a protective tube.

5. A fiber optic connector system for deploying optical fiber through a duct defined by a longitudinal duct axis and having a largest duct interior dimension perpendicular to the longitudinal duct axis, comprising:

an optical fiber defined by a longitudinal fiber axis extending between a trail end and a lead end of the optical fiber, the optical fiber including:

a first axial section having a longitudinal length of at least 1.0 meters and extending axially from the lead end of the optical fiber toward the trail end of the optical fiber, the first axial section being surrounded by a first outermost protective layer at a trail end of the first axial section, the first outermost protective layer having a largest dimension perpendicular to the longitudinal fiber axis that is less than the largest duct interior dimension; and

a second axial section having a longitudinal length of at least 0.1 meters and extending from the trail end of the optical fiber towards the lead end of the optical fiber, the second axial section being pre-terminated at a fiber optic connector positioned at the trail end of the optical fiber, the second axial section being surrounded by a sheath defining a second outermost protective layer extending axially from the connector to a lead end of the second axial section, the second outermost protective layer having a largest dimension perpendicular to the longitudinal fiber axis that is greater than or equal to the largest interior duct dimension.

6. A fiber optic connector system for deploying optical fiber through a duct defining a longitudinal duct axis and having a largest duct interior dimension perpendicular to the longitudinal axis, comprising:

an optical fiber defining a longitudinal fiber axis extending between a trail end and a lead end of the optical fiber, the optical fiber including:

a first axial section having a longitudinal length of at least 1.0 meters and extending axially from the lead end of the optical fiber towards the trail end of the optical fiber, the first axial section being surrounded by a first outermost protective layer at a trail end of the first axial section, the first outermost protective layer having a largest dimension perpendicular to the longitudinal fiber axis that is less than the largest duct interior dimension; and

a second axial section extending from the trail end of the optical fiber towards the lead end of the optical fiber, the second axial section being pre-terminated at a fiber optic connector positioned at the trail end of the optical fiber, the connector having a largest outer dimension perpendicular to the longitudinal fiber axis that is greater than or equal to the largest duct interior dimension.

7. The fiber optic connector system of claim 6, wherein the second axial section:
has a longitudinal length of at least 0.1 meters; and
is surrounded by a sheath defining a second outermost protective layer extending axially from the connector to a lead end of the second axial section, the second outermost protective layer having a largest dimension perpendicular to the longitudinal fiber axis that is greater than the first largest dimension.
8. The fiber optic connector system of claim 7, wherein the largest dimension of the second outermost protective layer is greater than or equal to the largest duct interior dimension.
9. The fiber optic connector system of any of claims 6-8, wherein the largest outer dimension of the connector is at least 10 millimeters.
10. The fiber optic connector system of any of claims 6-9, wherein the largest dimension of the second outermost protective layer is at least 4 millimeters.
11. The fiber optic connector system of any of claims 5-10, wherein the lead end of the optical fiber is pre-terminated with a partial fiber optic connector.
12. The fiber optic connector system of claim 11, wherein the partial fiber optic connector includes a ferrule that supports the optical fiber and does not include a connector housing.
13. The fiber optic connector system of any of claims 1-12, wherein the trail end of the first axial section abuts the lead end of the second axial section at a junction.

14. The fiber optic connector system of claim 13, wherein the junction is configured to coincide with a trail end of the duct.
15. The fiber optic connector system of any of claims 13 or 14, further comprising a coupler positioned at or adjacent the junction for coupling the optical fiber to a trail end of the duct.
16. The fiber optic connector system of claim 15, wherein the coupler includes a gas block adapted to seal the trail end of the duct around the optical fiber.
17. The fiber optic connector system of claim 5, wherein the largest dimension of the second outermost protective layer is at least 4 millimeters.
18. The fiber optic connector system of any of claims 5-17, wherein the first axial section has a longitudinal length of between 10 meters and 1,000 meters.
19. The fiber optic connector system of any of any of claims 5-17, wherein the first axial section has a longitudinal length of between 50 meters and 800 meters.
20. The fiber optic connector system of any of claims 5-17, wherein the first axial section has a longitudinal length less than or equal to 700 meters.
21. The fiber optic connector system of any of claims 5-20, wherein the second axial section has a longitudinal length of at least 0.5 meters.
22. The fiber optic connector system of any of claims 5-20, wherein the second axial section has a longitudinal length between 0.5 meters and 5 meters.
23. The fiber optic connector system of any of claims 5-20, wherein the first axial section has a longitudinal length between 1.0 meter and 3.0 meters.
24. The fiber optic connector system of any of claims 5-23, including a splice that splices together the first and second axial sections.

25. The fiber optic connector system of any of claims 5-23, wherein the first and second axial sections are not spliced to each other.
26. The fiber optic connector system of any of claims 5-25, wherein the second axial section includes a strength reinforcing component.
27. The fiber optic connector system of claim 26, wherein the strength reinforcing component comprises aramid yarn.
28. A method, comprising:
providing a duct having a length extending from a duct trail end to a duct lead end along a longitudinal duct axis;
providing an optical fiber defined by a longitudinal fiber axis extending between a fiber trail end and a fiber lead end of the optical fiber, the optical fiber including a first axial section having a longitudinal length of at least 1.0 meters and extending axially from the fiber lead end toward the fiber trail end, and a second axial section having a longitudinal length of at least 0.1 meters and extending from the first axial section towards the fiber trail end, the entire longitudinal length of the second axial section having a largest dimension perpendicular to the longitudinal fiber axis that exceeds a largest inner dimension of the duct perpendicular to the longitudinal duct axis;
advancing the lead end of the optical fiber through the entire length of the duct;
and
subsequent to the advancing, fastening a lead end of the second axial section to the duct trail end.
29. The method of claim 28, further comprising, prior to the advancing, terminating the fiber lead end of the optical fiber with a partial fiber optic connector.
30. The method of claim 29, wherein the partial fiber optic connector includes a ferrule.
31. The method of any of claims 28-30, further comprising, prior to the advancing, terminating the fiber trail end of the optical fiber with a fiber optic connector.

32. The method of any of claims 28-31, further comprising, subsequent to the advancing, sealing the duct trail end with a seal block.
33. The method of claim 32, wherein the fastening is performed with a tube connector, the tube connector including the seal block integrated therein.
34. The method of claim 33, wherein the seal block includes a grommet that plugs the duct trail end, and wherein the tube connector includes a blade or a tooth that cuts into an outer protective sheath of the second axial section.
35. The method of claim 28, further comprising, subsequent to the advancing, installing a connector body on the partial fiber connector to form a fiber optic connector at the lead end of the optical fiber.
36. The method of claim 28, further comprising, subsequent to the advancing, storing one or more loops of the first axial section at a fiber storage location.
37. The method of any of claims 28-36, wherein the advancing is performed by blowing the first axial section along the duct.
38. The method of any of claims 28-36, wherein the advancing is performed by pulling the first axial section along the duct.
39. The method of claim 28, further comprising, prior to the advancing, installing a pulling eye on the fiber lead end of the optical fiber and, subsequent to the advancing, removing the pulling eye from the fiber lead end of the optical fiber.
40. The method of any of claims 28-36, wherein the advancing is performed by pushing the first axial section along the duct.
41. A fiber optic connector system, comprising:
a spool; and

an optical fiber defined by a longitudinal fiber axis extending between a trail end and a lead end of the optical fiber, the optical fiber being spooled about the spool and including:

a first axial section having a longitudinal length of at least 1.0 meters and extending axially from the lead end of the optical fiber toward the trail end of the optical fiber, the first axial section being configured to be blown through a duct having a predefined size; and

a second axial section having a longitudinal length of at least 0.1 meters and extending from the trail end of the optical fiber towards the lead end of the optical fiber, the second axial section being pre-terminated at a fiber optic connector positioned at the trail end of the optical fiber, the second axial section not being configured to be blown through the duct,

wherein the first and second axial sections are wound about the spool such that the spool is configured to payout the first axial section before the second axial section.

42. The fiber optic connector system of claim 41, wherein the lead end of the optical fiber is terminated with a partial optical connector configured to be blown through the duct.

43. The fiber optic connector system of any of claims 41-42, further comprising a gas block positioned on the optical fiber and configured to plug a trail end of the duct.

44. A method, comprising:

paying out the blowable fiber section of the blown fiber assembly according to claims 1 or 2 by blowing the blowable fiber section through a duct.

45. The method of claim 44, further comprising coupling the sheathed fiber section to the duct.

46. The method of claim 44 or 45, further comprising connecting the hardened fiber optic connector to a port of a fiber access terminal.

47. The method of any of claims 44-46, further comprising, subsequent to the paying out, looping and storing a portion of the blowable fiber section.

FIG. 1

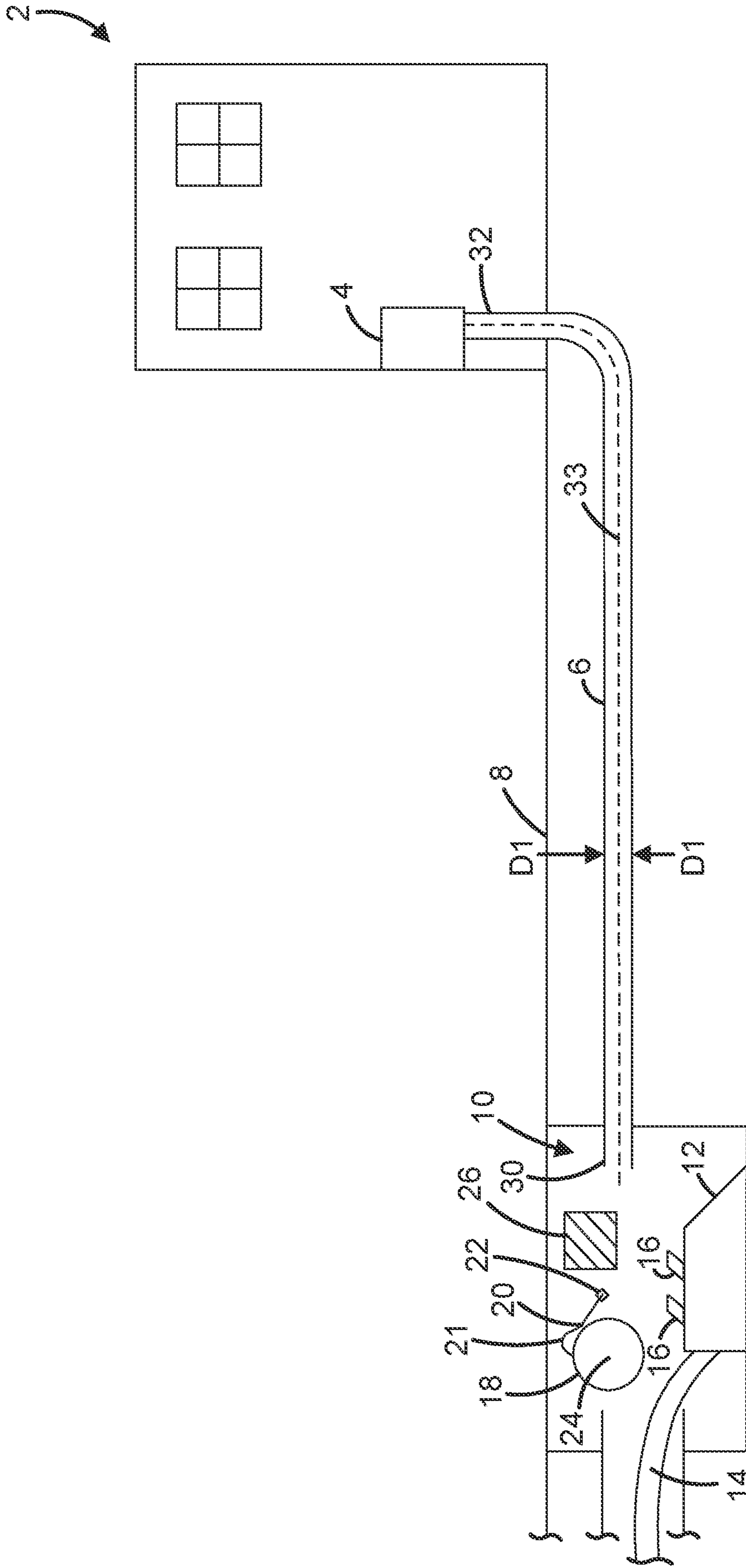

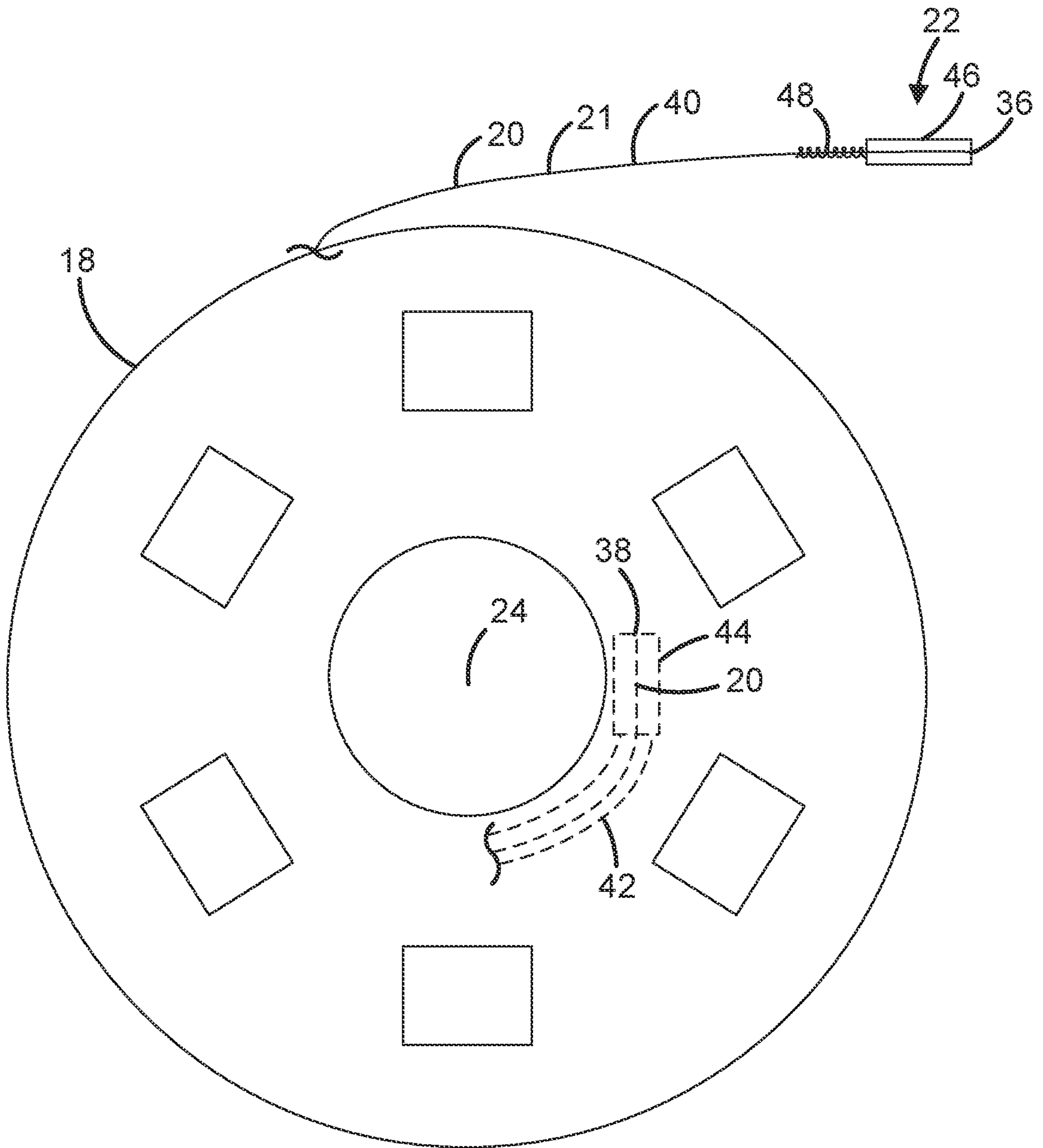

FIG. 2

FIG. 3

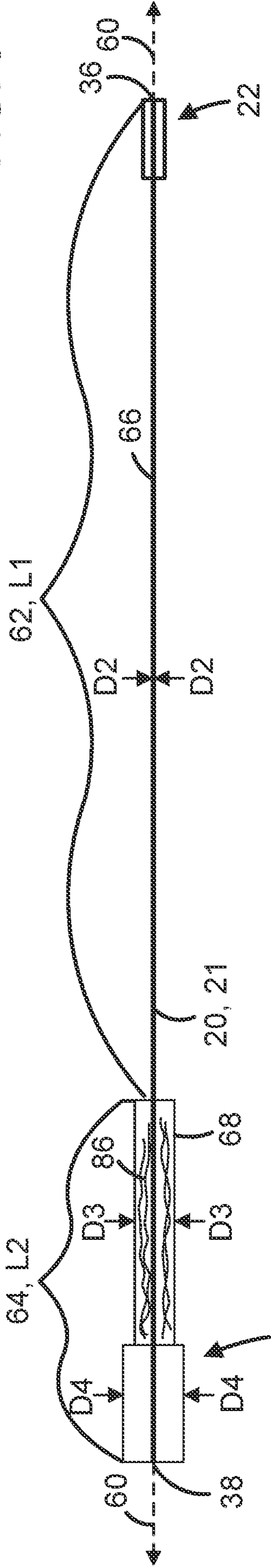
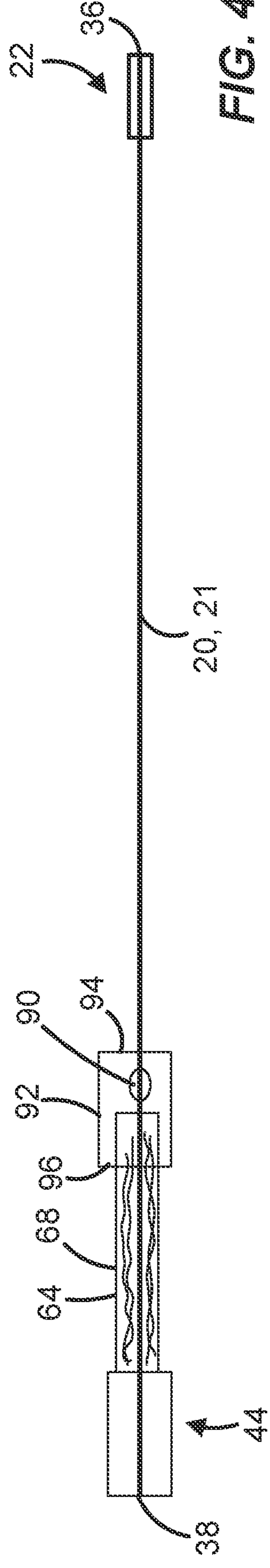

FIG. 4



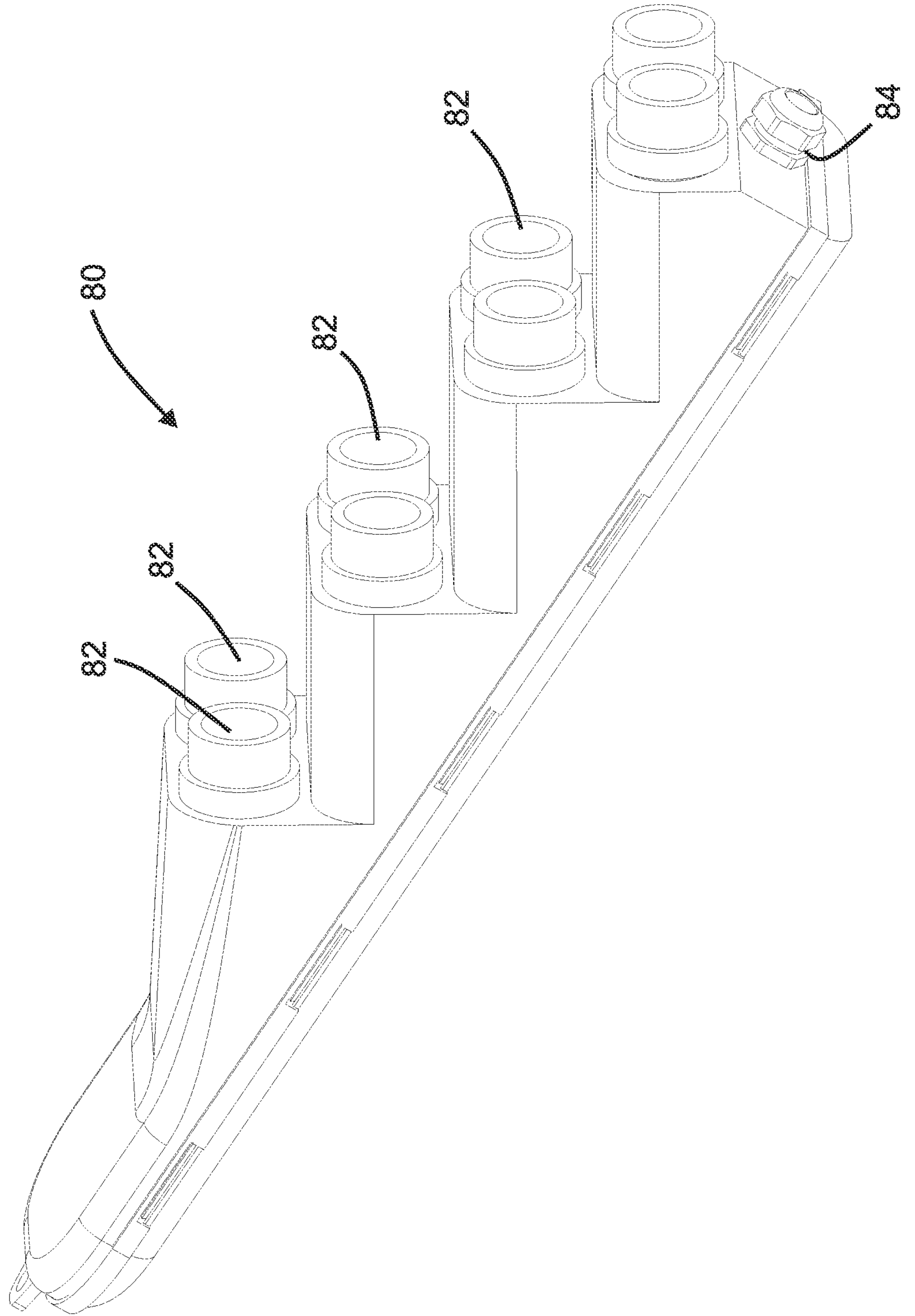
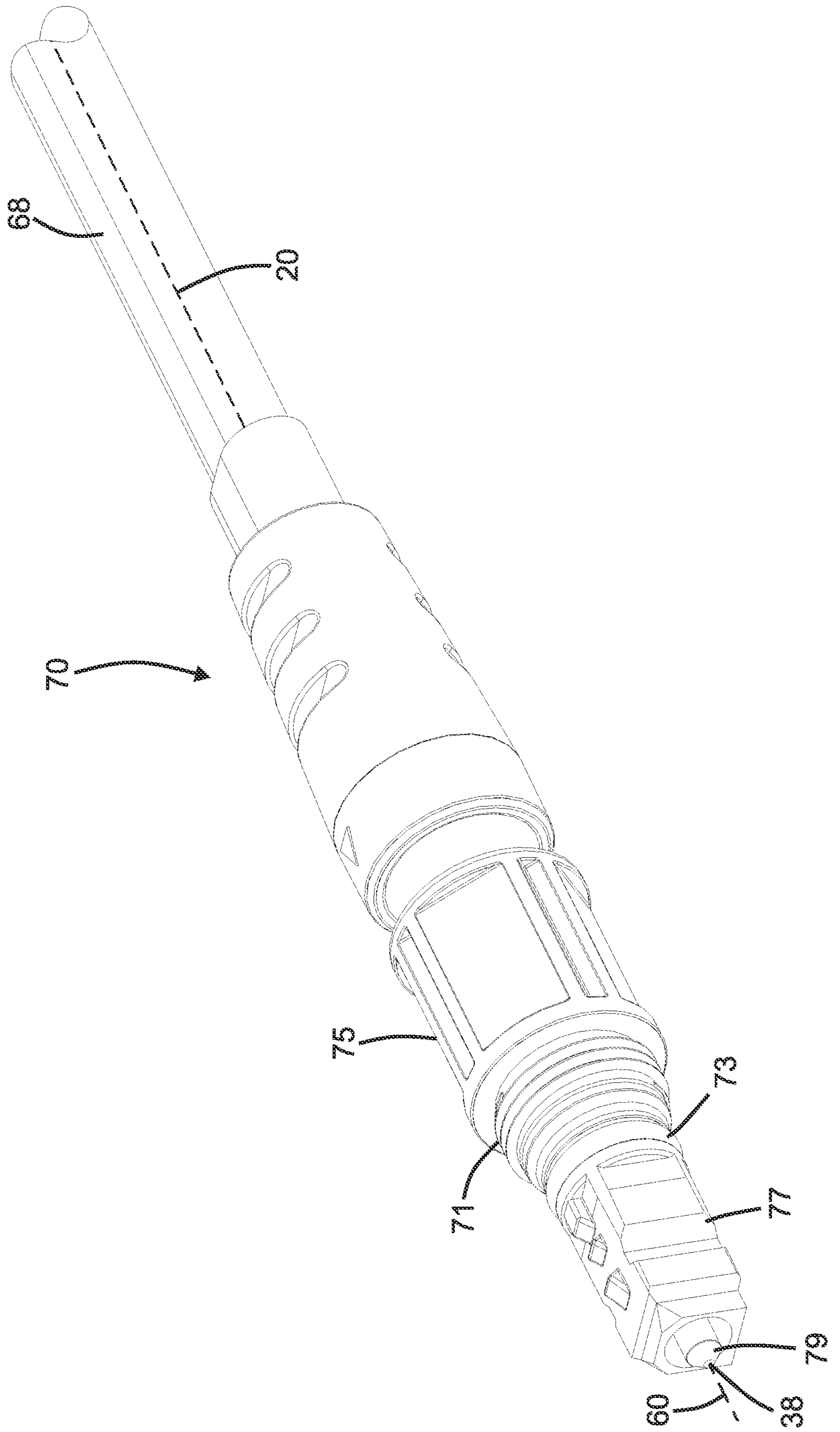

FIG. 5

FIG. 6



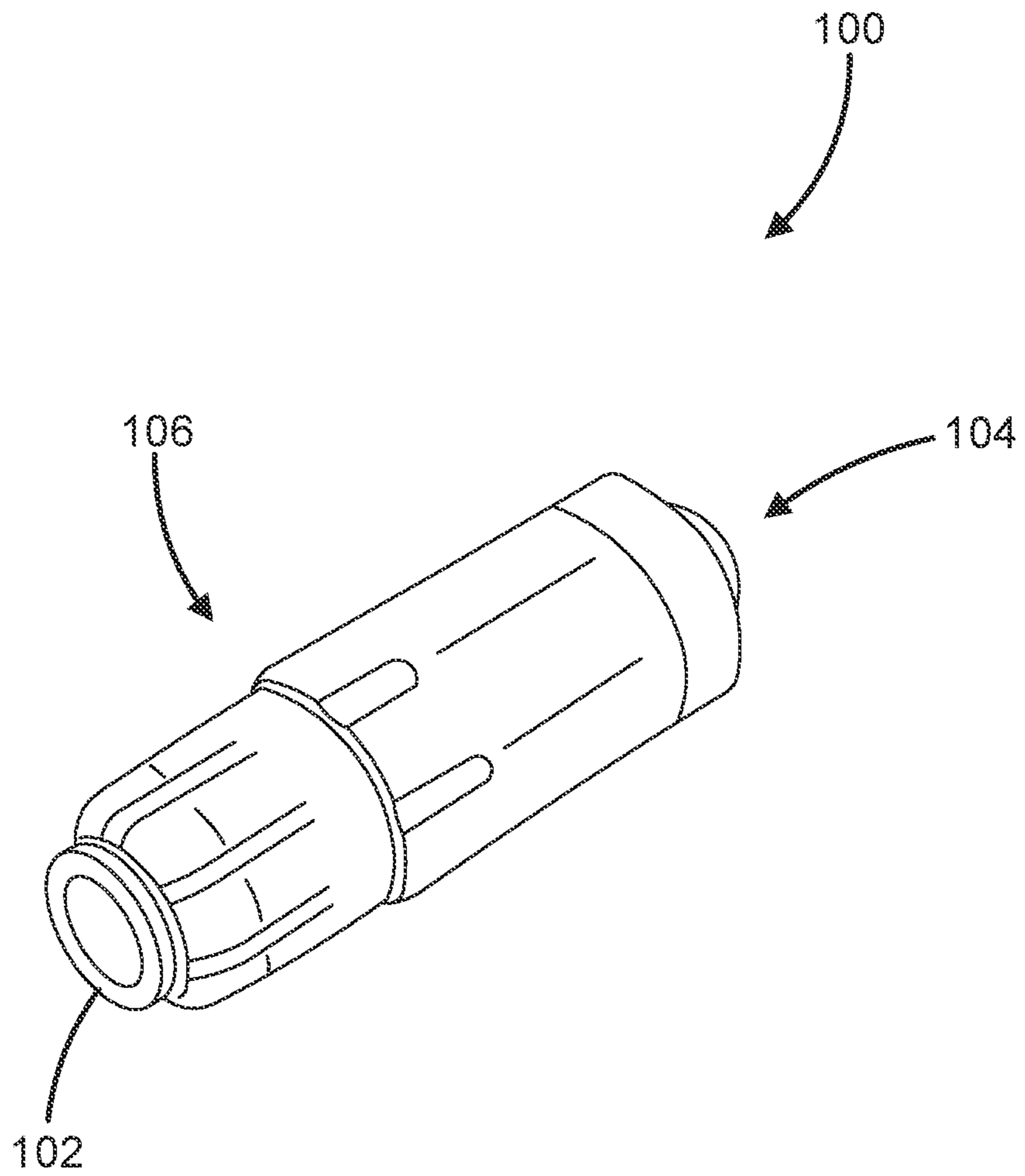
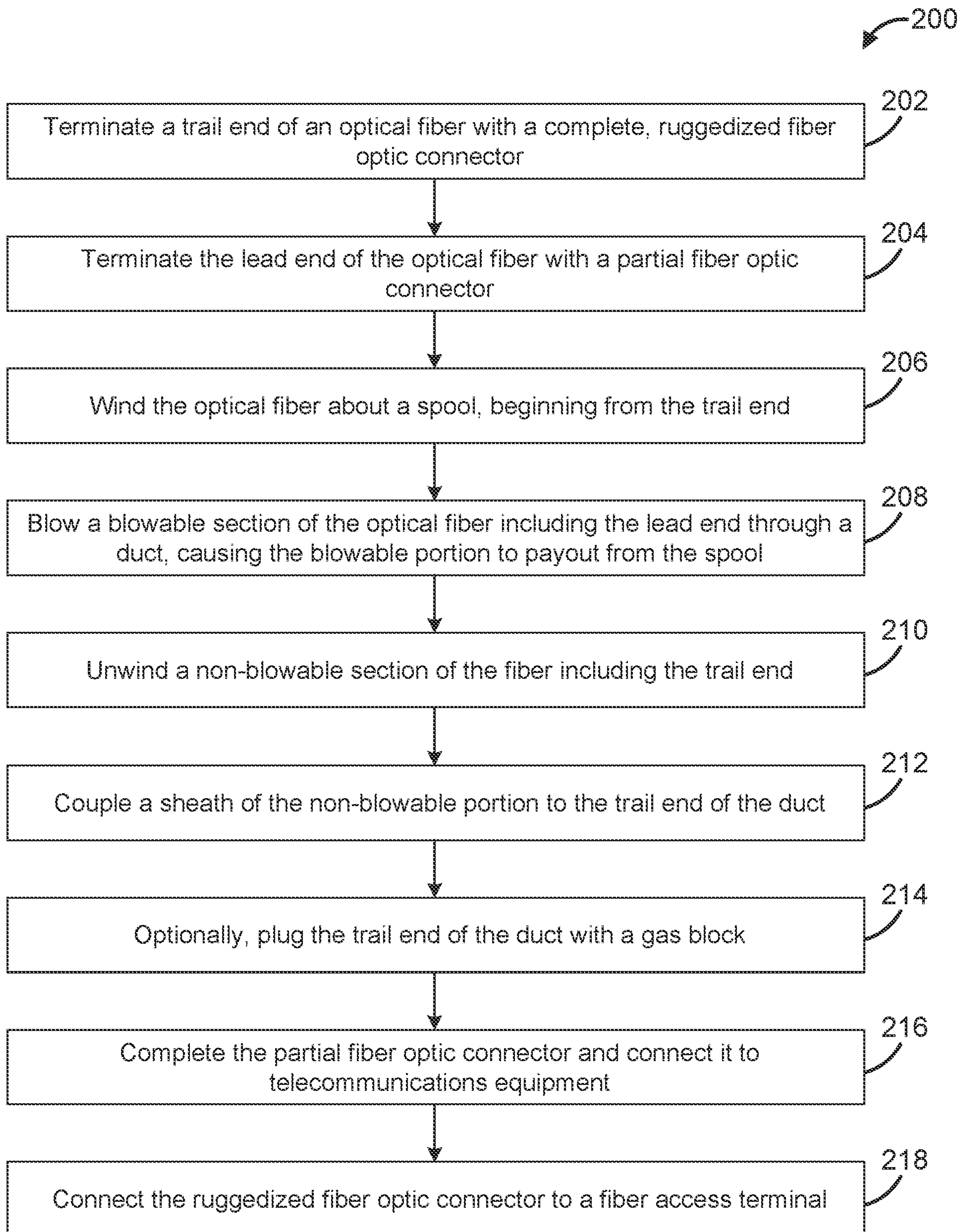

FIG. 7

7/7

**FIG. 8**

INTERNATIONAL SEARCH REPORT

International application No.

PCT/US2020/061525

A. CLASSIFICATION OF SUBJECT MATTER G02B 6/44(2006.01)i; G02B 6/38(2006.01)i; H04B 10/25(2013.01)i		
According to International Patent Classification (IPC) or to both national classification and IPC		
B. FIELDS SEARCHED		
Minimum documentation searched (classification system followed by classification symbols) G02B 6/44(2006.01); G02B 6/00(2006.01); G02B 6/255(2006.01); G02B 6/36(2006.01); G02B 6/38(2006.01); H02G 1/08(2006.01)		
Documentation searched other than minimum documentation to the extent that such documents are included in the fields searched Korean utility models and applications for utility models Japanese utility models and applications for utility models		
Electronic data base consulted during the international search (name of data base and, where practicable, search terms used) eKOMPASS(KIPO internal) & Keywords: blown fiber assembly, spool, optical, duct, dimension, connector, rotation		
C. DOCUMENTS CONSIDERED TO BE RELEVANT		
Category*	Citation of document, with indication, where appropriate, of the relevant passages	Relevant to claim No.
Y	WO 2018-146470 A1 (EMTELLE UK LTD.) 16 August 2018 (2018-08-16) page 3, line 15 - page 28, line 24; and figures 2-10	1-47
Y	US 9470850 B2 (ADC TELECOMMUNICATIONS, INC.) 18 October 2016 (2016-10-18) column 6, line 35 – column 7, line 23; and figure 3	1-47
A	US 2013-0216191 A1 (YAMAUCHI et al.) 22 August 2013 (2013-08-22) paragraphs [0061]-[0069]; and figures 5-6	1-47
A	US 5863083 A (GIEBEL et al.) 26 January 1999 (1999-01-26) claims 1-4 and figure 2	1-47
A	US 2011-0305424 A1 (PIERCE et al.) 15 December 2011 (2011-12-15) paragraphs [0058]-[0060]; and figure 4	1-47
<input type="checkbox"/> Further documents are listed in the continuation of Box C. <input checked="" type="checkbox"/> See patent family annex.		
* Special categories of cited documents: “A” document defining the general state of the art which is not considered to be of particular relevance “D” document cited by the applicant in the international application “E” earlier application or patent but published on or after the international filing date “L” document which may throw doubts on priority claim(s) or which is cited to establish the publication date of another citation or other special reason (as specified) “O” document referring to an oral disclosure, use, exhibition or other means “P” document published prior to the international filing date but later than the priority date claimed “T” later document published after the international filing date or priority date and not in conflict with the application but cited to understand the principle or theory underlying the invention “X” document of particular relevance; the claimed invention cannot be considered novel or cannot be considered to involve an inventive step when the document is taken alone “Y” document of particular relevance; the claimed invention cannot be considered to involve an inventive step when the document is combined with one or more other such documents, such combination being obvious to a person skilled in the art “&” document member of the same patent family		
Date of the actual completion of the international search 15 March 2021		Date of mailing of the international search report 15 March 2021
Name and mailing address of the ISA/KR Korean Intellectual Property Office 189 Cheongsu-ro, Seo-gu, Daejeon 35208, Republic of Korea Facsimile No. +82-42-481-8578		Authorized officer PARK, Hye Lyun Telephone No. +82-42-481-3463

INTERNATIONAL SEARCH REPORT
Information on patent family members

International application No.

PCT/US2020/061525

Patent document cited in search report			Publication date (day/month/year)	Patent family member(s)			Publication date (day/month/year)
WO	2018-146470	A1	16 August 2018	AU	2018-218520	A1	16 August 2018
				CA	3059123	A1	16 August 2018
				EP	3580593	A1	18 December 2019
				GB	2559489	A	08 August 2018
				GB	2559489	B	13 February 2019
				US	2020-0012062	A1	09 January 2020
				WO	2018-146470	A4	16 August 2018
US	9470850	B2	18 October 2016	AP	2014007949	A0	30 September 2014
				AP	201407949	A0	30 September 2014
				AP	201407949	D0	30 September 2014
				AU	2013-203887	A1	05 September 2013
				AU	2013-203887	B2	19 February 2015
				AU	2015-202687	A1	04 June 2015
				AU	2015-202687	B2	06 April 2017
				CA	2864886	A1	29 August 2013
				CL	2014002213	A1	02 January 2015
				CN	104246565	A	24 December 2014
				CN	104246565	B	12 April 2017
				CN	107132622	A	05 September 2017
				CN	107132622	B	18 October 2019
				CO	7141439	A2	12 December 2014
				EC	SP14019047	A	31 August 2015
				EP	2817668	A2	31 December 2014
				EP	2817668	B1	22 January 2020
				EP	2817668	B8	11 March 2020
				EP	3650898	A1	13 May 2020
				ES	2775232	T3	24 July 2020
				IL	234199	A	30 October 2014
				IN	1743KON2014	A	23 October 2015
				JP	2015-508188	A	16 March 2015
				KR	10-2014-0126393	A	30 October 2014
				MX	2014009947	A	10 November 2014
				MX	338237	B	08 April 2016
				MX	357669	B	18 July 2018
				NZ	629040	A	23 December 2016
				PE	20142200	A1	11 January 2015
				PE	22002014	A1	11 January 2015
				PH	12014501873	A1	24 November 2014
				RU	2014138122	A	10 April 2016
				SG	11201405020	A	26 September 2014
US	10353154	B2	16 July 2019				
US	2014-0064665	A1	06 March 2014				
US	2015-0293313	A1	15 October 2015				
US	2017-0139152	A1	18 May 2017				
US	2020-0012054	A1	09 January 2020				
US	9016953	B2	28 April 2015				
WO	2013-126429	A2	29 August 2013				
WO	2013-126429	A3	31 October 2013				
ZA	201406828	B	23 December 2015				
US	2013-0216191	A1	22 August 2013	CN	103189771	A	03 July 2013

INTERNATIONAL SEARCH REPORT
Information on patent family members

International application No.

PCT/US2020/061525

Patent document cited in search report	Publication date (day/month/year)	Patent family member(s)	Publication date (day/month/year)
		CN 103189771 B	20 January 2016
		EP 2645140 A1	02 October 2013
		EP 3324227 A1	23 May 2018
		HK 1186778 A1	21 March 2014
		JP 5857968 B2	10 February 2016
		KR 10-1888977 B1	16 August 2018
		KR 20130140676 A	24 December 2013
		US 9229173 B2	05 January 2016
		WO 2012-056691 A1	20 March 2014
		WO 2012-056691 A1	03 May 2012

US 5863083 A	26 January 1999	None	

US 2011-0305424 A1	15 December 2011	AT 535976 T	15 December 2011
		AU 2005-276963 A1	02 March 2006
		AU 2005-276963 B2	19 August 2010
		CN 101010843 A	01 August 2007
		CN 101010843 C	01 August 2007
		DK 1787369 T3	27 February 2012
		EP 1787369 A1	23 May 2007
		EP 1787369 B1	30 November 2011
		ES 2378075 T3	04 April 2012
		MY 143159 A	31 March 2011
		NZ 553049 A	30 September 2010
		PT 1787369 E	17 February 2012
		US 8165444 B2	24 April 2012
		WO 2006-021055 A1	02 March 2006
