

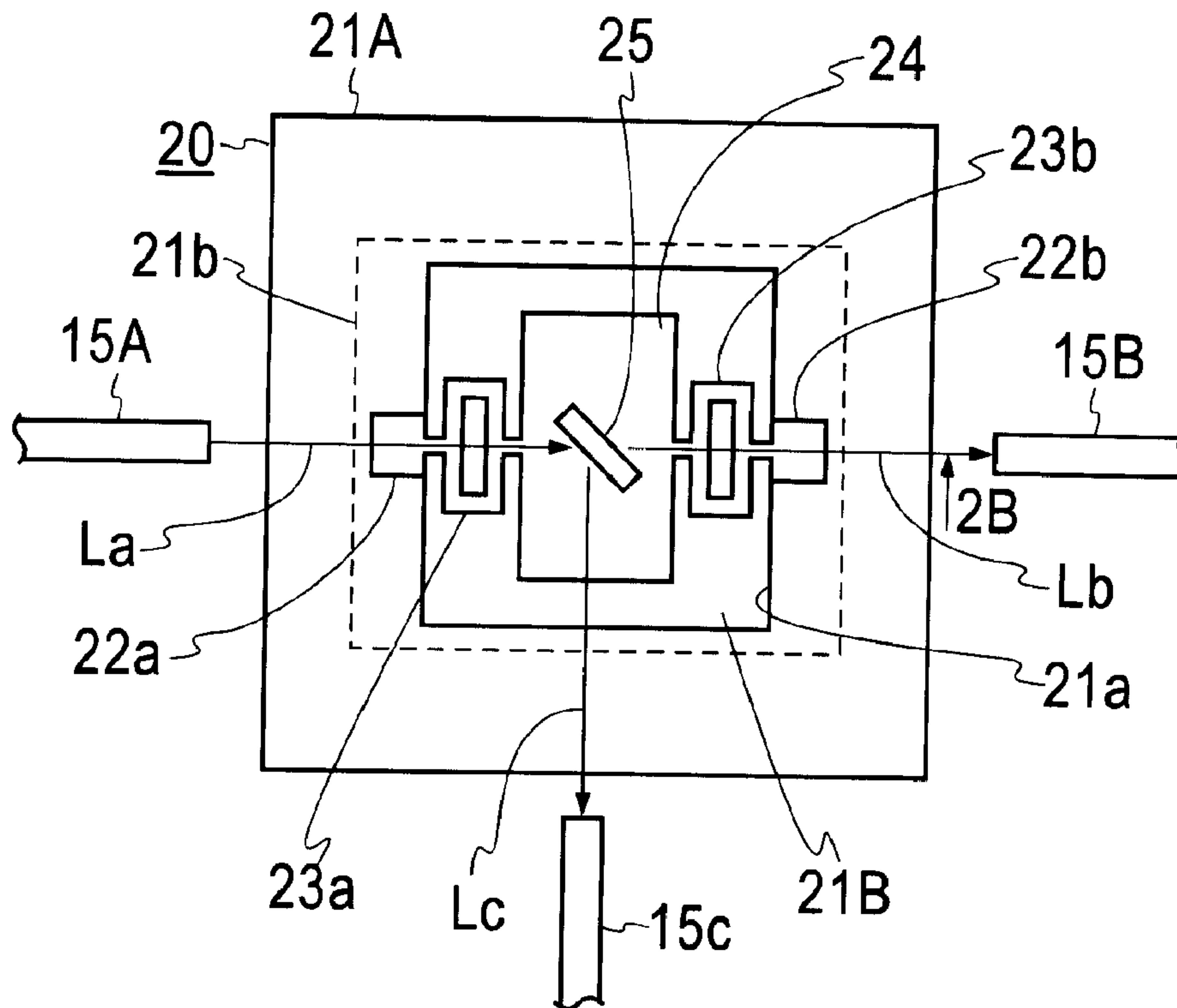

(22) Date de dépôt/Filing Date: 2000/03/02
 (41) Mise à la disp. pub./Open to Public Insp.: 2000/09/04
 (45) Date de délivrance/Issue Date: 2002/11/12
 (30) Priorités/Priorities: 1999/03/04 (057427/99) JP;
 1999/03/05 (058297/99) JP

(51) Cl.Int.⁷/Int.Cl.⁷ G02B 26/08
 (72) Inventeurs/Inventors:
 KATO, YOSHICHIKA, JP;
 MORI, KEIICHI, JP
 (73) Propriétaire/Owner:
 JAPAN AVIATION ELECTRONICS INDUSTRY
 LIMITED, JP
 (74) Agent: KIRBY EADES GALE BAKER

(54) Titre : COMMUTATEUR OPTIQUE ET METHODE DE FABRICATION CONNEXE
 (54) Title: OPTICAL SWITCH AND METHOD OF MAKING THE SAME



(57) Abrégé/Abstract:

An optical switch a conductive silicon substrate is coated all over the surface area with a silicon film to form in parallel to the substrate surface a movable contact and elastic support portions for coupling the movable electrode and for elastically supporting its movable electrode in a manner to be displaced vertically, the surface region of the conductive silicon substrate facing the movable electrode and the elastic support portions is etched away to form therein a low-floor portion as a fixed electrode surface opposite the movable electrode in parallel thereto, and a micro mirror having a vertical reflecting surface is mounted on the movable electrode portion.

ABSTRACT OF THE DISCLOSURE

An optical switch a conductive silicon substrate is coated all over the surface area with a silicon film to form in parallel to the substrate surface a movable contact and elastic support portions for coupling the movable electrode and for elastically supporting its movable electrode in a manner to be displaced vertically, the surface region of the conductive silicon substrate facing the movable electrode and the elastic support portions is etched away to form therein a low-floor portion as a fixed electrode surface opposite the movable electrode in parallel thereto, and a micro mirror having a vertical reflecting surface is mounted on the movable electrode portion.

OPTICAL SWITCH AND METHOD OF MAKING THE SAME

BACKGROUND OF THE INVENTION

The present invention relates to an optical switch for use in optical
5 communication systems or the like and a method of making the same.

With recent developments of optical networks, optical switches are
now receiving attention as optical devices of the utmost importance. Also
there is a demand for their miniaturization in accordance with the present
trend toward increasingly high-capacity optical networks. To meet the
10 demand, a miniaturized optical switch has been proposed which has a
movable switching portion formed using micromachine technology. Its
structure is depicted in Fig. 1. Reference numeral 10 denotes a silicon (Si)
substrate having a groove cut therein by micromachining, wherein there are
formed a pair of parallel cantilevers 14a and 14b coupled together at their
15 free ends. Fixedly disposed on the substrate 10 near opposite ends of the
cantilevers 14a and 14b lengthwise thereof are guide blocks 11 and 13.
Disposed adjacent the guide block 13 is another guide block 12 formed
integrally with the cantilever free end coupling portion. The guide block 12
is coated over the entire area of its surface or underside with a soft magnetic
20 film 19c. These guide blocks 11, 12 and 13 have the same height.

An optical fiber 15A is fixed its one end on the guide block 12 and
extended and supported across the top of the guide block 11. Two optical
fibers 15B and 15C are fixed at one end in parallel to the guide block 13.
On the substrate 10 there are mounted magnetic yokes 19a and 19b at both
25 sides of the guide block 12, the magnetic yokes 19a and 19b having wound
thereon coils 17a and 17b, respectively. The magnetic yokes 19a and 19b
are split centrally thereof and have permanent magnets 18a and 18b inserted

between the gaps, respectively.

With the optical switch of such a construction as described above, the application of a driving voltage to, for example, the coil 17a causes it to attract the soft magnetic film 19c coated on the guide block 12 to resiliently bend the cantilevers 14a and 14b toward the magnetic yoke 19a, bringing the light-emitting end of the optical fiber 15A to the position where it stands opposite the light-receiving end of the optical fiber 15B. On the contrary, the voltage application to the coil 17b of the yoke 19b causes the light-emitting end of the optical fiber 15A to stand opposite the light-receiving end of the optical fiber 15C. In this way, light emitted from the optical fiber 15A can selectively be launched into the optical fibers 15B and 15C.

The manufacture of such a conventional optical switch encounters a difficulty in the miniaturization of the magnetic yokes 19a and 19b with the coils 17a and 17b wound thereon; for example, the substrate 10 inevitably becomes as large as 20 by 17 mm or so. It has also been proposed to miniaturize the optical switch by forming optical waveguides in the cantilevers 14a and 14b in Fig. 1, but the proposed optical switch structure still electromagnetically drives the cantilevers and measures about 16 by 18 mm. Besides, the proposed optical switch has a defect that the insertion loss of the waveguide is as large as several dB.

SUMMARY OF THE INVENTION

It is therefore an object of the present invention to provide an optical switch that can be driven at a low voltage and hence can be miniaturized, and a method of making such an optical switch.

-3-

In accordance with one aspect of the present invention there is provided an optical switch comprising: substrate means; fixed electrode means fixedly secured to said substrate means with the surface of said fixed electrode means held lower than and in parallel to the surface of said substrate means; movable
5 electrode means disposed opposite to said fixed electrode means in spaced relation thereto; elastic support means for coupling said movable electrode means and said substrate means and for elastically supporting said movable electrode means so that said movable electrode means can be displaced vertically to said fixed electrode means; and optical path switching means
10 provided on the surface of said movable electrode means opposite said fixed electrode means and having a light receiving surface perpendicular to said surface of said movable electrode means; wherein, by ON-OFF control of voltage application across said movable electrode means and said fixed electrode means, said movable electrode means is displaced toward said fixed electrode
15 means and returned to its normal position to selectively switch the optical path of an incident light means by said optical path switching means.

In accordance with another aspect of the present invention there is provided a method for making an optical switch in which an optical path switching element mounted on a movable electrode is displaced to switch the
20 optical path of an incident light beam, said method comprising the steps of: (a) forming on a silicon substrate a pattern containing a movable electrode portion and an elastic support portion coupled thereto by a conductive silicon film; (b) making an opening by etching away that region of said silicon substrate which is opposite to at least said movable electrode portion and said elastic support

-4-

portion; (c) attaching a conductive substrate to the underside of said silicon substrate so that one surface region of said conductive substrate serves as a fixed electrode opposite but spaced apart from at least said movable electrode portion in said opening; and (d) forming said optical path switching element on
5 said movable electrode portion.

In accordance with yet another aspect of the present invention there is provided a method for making an optical switch in which an optical path switching element mounted on a movable electrode is displaced to switch the optical path of an incident light beam, said method comprising the steps of: (a)
10 forming a first polysilicon film over the entire surface area of a conductive silicon substrate; (b) forming a pattern, which contains a movable electrode portion and an elastic support portion coupled to said movable electrode portion in spaced and parallel relation thereto, all over said first polysilicon film by a second polysilicon film of a preselected conductivity type; (c) forming a low-floor
15 portion as a fixed electrode by etching away that surface region of said conductive silicon substrate which is opposite at least said movable electrode portion and said elastic support portion; and (d) forming on said optical path switching element on said movable electrode portion.

20 BRIEF DESCRIPTION OF THE DRAWINGS

Fig. 1 is a plan view depicting an example of a conventional optical switch;

Fig. 2A is a plan view illustrating an optical switch according to a first embodiment of the present invention;

-4a-

Fig. 2B is a sectional view taken along the line 2B-2B in Fig. 2A;

Figs. 3A through 3I are sectional views showing a sequence of steps involved in the manufacture of the optical switch according to the first embodiment; Fig. 4A is a plan view illustrating an optical switch according to a
5 second embodiment of the present invention;

Fig. 4B is a sectional view taken along the line 4B-4B in Fig. 4A;

Figs. 5A through 5I are sectional views showing a sequence of steps involved in the manufacture of the optical switch according to the second embodiment;

10 Fig. 6 is a plan view of a matrix switch array using optical switches according to the first embodiment;

Fig. 7 is a plan view of a matrix switch array using optical switches according to the second embodiment;

Figs. 8A through 8H are sectional views depicting a sequence of steps

involved in the manufacture of a modified form of the optical switch according to the second embodiment;

Fig. 9A is a plan view illustrating an optical switch according to a third embodiment of the present invention;

5 Fig. 9B is a sectional view taken along the line 9B-9B in Fig. 9A;

Fig. 10 is a plan view depicting a movable electrode-elastic support pattern;

Fig. 11 is a plan view depicting another movable electrode-elastic support pattern;

10 Fig. 12 is a plan view depicting another movable electrode-elastic support pattern;

Fig. 13 is a plan view depicting another movable electrode-elastic support pattern;

15 Fig. 14 is a plan view depicting another movable electrode-elastic support pattern;

Fig. 15 is a plan view depicting another movable electrode-elastic support pattern;

Fig. 16 is a plan view depicting another movable electrode-elastic support pattern;

20 Fig. 17 is a plan view depicting still another movable electrode-elastic support pattern;

Fig. 18 is a plan view showing an optical switch module using the optical switch of the present invention;

25 Fig. 19 is a graph showing minimum driving voltages measured with respect to the switch size, using the thickness of the elastic support in the Fig. 18 structure as a parameter; and

Fig. 20 is a graph showing the relationship between the minimum

driving voltage and power consumption measured for various switch sizes.

DETAILED DESCRIPTION OF THE PREFERRED EMBODIMENTS

The optical switch according to the present invention has a basic
5 structure wherein: a movable electrode is elastically held in an opening of a
frame-like substrate; a mirror is fixedly mounted on the movable electrode at
right angles to the electrode surface; a fixed electrode is mounted on the
substrate in opposed but spaced relation to the underside of the movable
electrode; a driving voltage is applied across the movable and the fixed
10 electrode to attract the former toward the latter by electrostatic force; and the
optical path from the light-emitting end of a first optical fiber to the light-
receiving end of a second optical fiber is switched ON and OFF by the mirror
mounted on the movable electrode.

FIRST EMBODIMENT

15 Figs, 2A and 2B are plan and sectional views of an optical switch 20
according to a first embodiment of the present invention. In an opening 21a
of, for example, a rectangular-frame-shaped silicon (Si) substrate 21A, a
movable electrode 24 of a rectangular shape in this example is placed in
parallel to the substrate 21A with two opposite sides of the electrode 24
20 coupled to stationary portions 22a and 22b on the frame-shaped substrate
21A through elastic supports portions 23a and 23b, respectively. Supported
by the flexible elastic support portions 23a and 23b, the movable electrode 24
is allowed to move vertically with respect to the substrate surface. On the
movable electrode 24 there is mounted a micro mirror 25 with its reflecting
25 surface held at right angles to the movable electrode surface.

On the other hand, the opening 21a of the substrate 21A is stopped up
from the underside thereof with a conductive substrate 21B that is disposed

-7-

as a fixed electrode in opposed but spaced relation to the surface region of the substrate 21A which contains the movable electrode 24 and the support portions 23a and 23b.

In this embodiment the conductive substrate 21B is machined to conform to the opening 21a and bonded to the substrate 21A from the underside thereof. The top of the conductive substrate 21B fitted in the opening 21a, that is, the fixed electrode surface is held at a predetermined level below the underside of the substrate 21A--this provides the maximum amount of displacement for the movable electrode 24 that allows the micro mirror 25 to move up and down to inhibit and permit the passage of a light beam.

In the optical switch 20 of such a construction the stationary portions 22a, 22b, the elastic support portions 23a, 23b and the movable electrode 24 are integrally formed of the same conductive material such as polysilicon. By applying a voltage across the movable electrode 24 and the conductive substrate 21B, the former is displaced toward the latter by electrostatic force so that the micro mirror 25 standing upright on the movable electrode 24 moves vertically with respect to the substrate surface to thereby switch the optical path of a light beam incoming from the direction parallel to the substrate surface.

In Fig. 2A, reference numerals 15A, 15B and 15C denote optical fibers disposed, for instance, around the optical switch 20, La light incident on the optical switch 20, and Lb and Lc light emitted or emerged from the optical switch 20. When inserted in the optical path, the micro mirror 25 reflects the incident light La and launches the reflected light Lc into the optical fiber 15C. When the micro mirror 25 is displaced toward the fixed electrode side stays out of the optical path, the incoming light La is launched

intact as the outgoing light Lc into the optical fiber 15b.

Fig. 3 illustrates, in section, a sequence of steps involved in the manufacture of the optical switch 20 depicted in Figs. 2A and 2B. A description will be given below of each step of fabrication.

5 Step S1 (Fig. 3A): A silicon substrate of a square configuration, in this example, is prepared as the substrate 21A, which is then coated all over its surface with an SiO₂ protective film 2a about 1 μm thick.

Step S2 (Fig. 3B): The protective film 2a is selectively etched away to make holes 2ah measuring, for example, approximately 100 by 100 μm, where the stationary portions 22a and 22b will ultimately be formed.

Step S3 (Fig. 3C): A conductive polysilicon film 2b is formed to a thickness of about 3 μm over the entire surface area of the SiO₂ film 2a including the holes 2ah for the purpose of forming the stationary portions 22a, 22b, the elastic support portions 23a, 23b and the movable electrode 24 as a unitary structure with one another. The conductive polysilicon film 2b is a P-type one with boron (B) thermally diffused thereinto.

Step S4 (Fig. 3D): The polysilicon film 2b is selectively etched away to form the movable electrode 24, the elastic support portions 23a, 23b and the stationary portions 22a, 22b.

20 Step S5 (Fig. 3E): An SiO₂ protective film 2c is formed all over the top and underside of the substrate assembly.

Step S6 (Fig. 3F): The protective film 2c is selectively etched away that region of the underside of the substrate 21A (a broken-line area 21b in Fig. 2A) which corresponds to the movable electrode 24 and the elastic support portions 23a and 23b.

25 Step S7 (Fig. 3G): The substrate 21A is subjected to anisotropic etching using a KOH solution to form the opening 21a.

-9-

Step S8 (Fig. 3H): The remaining protective films 2a and 2c are removed.

Step S9 (Fig. 3I): The conductive substrate 21B machined as required to form the fixed electrode is fitted into the opening 21a and bonded to the substrate 21A from the underside thereof. The conductive substrate 21B in this example is an N-type conductive silicon substrate.

Finally, though not shown, the micro mirror 25 is placed on the movable electrode 24. The micro mirror 25 is formed by: depositing a metal land as a plating seed at the position where to form the micro mirror 25 on the movable electrode 24, for example, in Fig. 3I; coating a resist film all over the substrate surface to a thickness a little higher than the height of the micro mirror 25 to be formed; selectively etching away the resist film to make a hole that has a shape corresponding to the micro mirror 25 to be formed and extends down to the metal land; filling the hole with gold (Au), nickel (Ni), or similar metal by plating; and removing the resist film to form the micro mirror 25 on the movable electrode 24. For example, in the optical switch module described later on, a gold block of a size measuring 45 by 200 by 40 μm is formed as the micro mirror. Alternatively, the micro mirror may be obtained by forming a mirror support panel of a resist on the movable electrode 24 at the position where to form the micro mirror and then vapor evaporating gold, nickel, or like metal onto the support panel.

As described above, the optical switch according to the present invention, depicted in Figs. 2A and 2B, utilizes electrostatic drive in place of electromagnetic one, and hence it need not be provided with the magnetic yokes 19a, 19b, the coils 17a, 17b and the permanent magnets 18a, 18b shown in Fig. 1; therefore, the optical switch of the present invention can be made smaller accordingly.

SECOND EMBODIMENT

With the structure in which the opening 21a is formed by selectively etching away the substrate 21A from the underside thereof and the
5 conductive substrate is bonded to the opening 21a from the underside of the substrate 21A as described above, the substrate 21A has a frame-like configuration and hence needs to have a frame width large enough to provide sufficient mechanical strength of the substrate itself and sufficient area for bonding thereto the substrate 21B. To meet the requirements, it is necessary
10 that outer dimensions of the optical switch 20 be designed a little large relative to the device area surrounded by the broken line 21b in Fig. 2A. In the case of using a silicon (Si) substrate as the substrate 21A and forming therein the opening 21a by anisotropic etching, the area of the opening 21a in the underside of the substrate 21A needs to be made particularly large since
15 the inner face of the opening 21a is tapered as depicted in Fig. 2B. This makes the substrate 21A larger and constitutes an obstacle to the downsizing of the optical switch.

Moreover, the bonding of the conductive substrate 21B inevitably decreases the accuracy of fabrication, and it cannot be said that positioning
20 accuracy of the top of the conductive substrate 21B, that is, positioning accuracy of the fixed electrode surface is high.

Besides, the fabrication of the above optical switch involves the bonding step in addition to the series of film forming and etching steps, and hence it is complex in process and time- and labor-consuming. A
25 description will be given below of optical switch structures intended to overcome such disadvantages.

In the second embodiment of the invention, a movable electrode is

mounted on a conductive substrate in parallel to the substrate surface and is made displaceable at right angles to the substrate surface, and a micro mirror is mounted on the movable electrode. A low-floor portion is formed in the substrate surface by etching, and the bottom of the low-floor area is used as
5 the fixed electrode surface that is opposite and parallel to the movable electrode.

Figs. 4A and 4B depict the optical switch according to the second embodiment, wherein the parts corresponding to those in Figs. 2A and 2B are identified by the same reference numerals. In this embodiment the substrate
10 21 is formed of a conductive material and has a low-floor portion 21L formed in its surface by etching, and the floor surface of the low-floor portion 21L constitutes the fixed electrode surface adjacent but parallel to the movable electrode 24; namely, the substrate 21 serves a fixed electrode. The
movable electrode 24 is supported on the substrate 21 by the elastic support
15 portions 23a and 23b formed integrally with the electrode 24 as in the first embodiment shown in Figs. 2A and 2B. Mounted on the movable electrode 24 is the micro mirror 25.

Referring next to Figs. 5A through 5I, a description will be given of a method for making the optical switch depicted in Figs. 4A and 4B.

20 Step S1 (Fig. 5A): For example, an N-type conductive silicon substrate 21 of a square configuration is coated all over its top surface with a P-type conductive polysilicon film 2d with boron (B) thermally diffused thereinto.

Step S2 (Fig. 5B): An SiO₂ protective film 2a is formed all over the
25 surface of the polysilicon film 2d.

Step S3 (Fig. 5C): The protective film 2a is selectively removed to make therein holes 2ah at those positions where to form the stationary

portions 22a and 22b.

Step S4 (Fig. 5D): A P-type conductive polysilicon film 2b is formed all over the surface of the protective film 2a including the exposed areas 2ah.

Step S5 (Fig. 5E): The P-type conductive polysilicon film 2b is
5 selectively etched away to form the movable electrode 24, the elastic support portions 23a, 23b and the stationary portions 22a, 22b. At this time, a plurality of through holes 24h are bored in matrix form through the movable electrode 24 as depicted in Fig. 4A.

Step S6 (Fig. 5F): An SiO₂ protective film 2c is formed over the
10 entire areas of the top and underside of the substrate assembly.

Step S7 (Fig. 5G): The SiO₂ films 2a and 2c on the upper side (on the side near the movable electrode 24) of the substrate assembly are patterned to form through holes 24t which extend down to the polysilicon film 2d in alignment with the through holes 24h of the movable electrode 24. At the
15 same time, the SiO₂ films 2a and 2c are patterned so that their outside shape becomes slightly larger than the outside shape of the movable electrode 24 and the elastic support portions 23a, 23b but larger than the outside shape of the stationary portions 22a and 22b as required.

Step S8 (Fig. 5H): The substrate 21 is etched using a KOH solution.
20 The KOH solution flows to the polysilicon film 2d through the through holes 24t, by which the polysilicon film 2d of an isotropic etching property is etched away to expose the silicon substrate 21, which also undergo anisotropic etching to form the low-floor portion 21L. Incidentally, the polysilicon film 2d underlying the stationary portions 22a and 22b is covered
25 with the protective films 2a and 2c which are sufficiently thicker than the film 2d as referred to above, and hence the polysilicon film 2d remains unetched (that is, the thickness of the polysilicon film 2d and the mask

-13-

pattern diameters of the protective films 2a and 2c overlying the stationary portions 22a and 22b are determined accordingly).

Step S9 (Fig. 5I): The protective films 2a and 2c are removed.

5 This is followed, though not shown, by placing the micro mirror 25 on the movable electrode 24 to complete the optical switch 20. The micro mirror 25 is formed by the same method as described previously with respect to the first embodiment.

10 In step S1 described above, the boron (B) thermally diffused into the polysilicon film 2d diffuses down to the surface region of the N-type silicon substrate 21 to form a PN junction. Accordingly, when a DC driving voltage is applied across the movable electrode 24 and the silicon substrate 21 with the former negative with respect to the latter, the PN junction becomes reverse-biased, inhibiting the passage of DC current through the stationary part 22 and the polysilicon film 2d.

15 With the manufacturing method described above, after the formation of the movable electrode 24, the elastic support portions 23a, 23b and so forth, the low-floor portion 21L deep enough to allow displacement of the movable electrode 24 can be formed in the substrate 21 by selectively etching it away from the side where the above-mentioned elements have been provided. And the bottom of the low-floor area 21L serves as the fixed electrode surface opposite to the movable electrode 24.

20 Thus, this embodiment dispenses with the bonding step needed in the manufacture of the optical switch 20 of the Fig. 2 embodiment, and hence it permits accurate and easy fabrication of the optical switch accordingly.

25 Besides, since there is no need of forming the opening 21a in the substrate 21A as shown in Figs. 2A and 2B, that is, since the substrate 21 is not frame-shaped, the region needed for providing the required frame width

becomes unnecessary, making the optical switch 20 smaller accordingly.

Figs. 6 and 7 conceptually show the difference in size between two-by-two arrays of optical switches of the Fig. 2 and the Fig. 4 structure, respectively.

5 In the case of Fig. 6, when the opening 21a is formed by anisotropic etching in the substrate 21A of, for example, 400 μm thick, the formation of the opening 21a measuring 1 by 1 mm in the substrate surface requires the formation of an approximately 1.6 by 1.6 mm etching window 21w in the underside of the substrate. In view of the mechanical strength and the
10 bonding area for the substrate 21B, it is necessary that widths W_1 and W_2 be at least 1 mm or so. As will be seen from Fig. 6, these frame portions cause a significant loss of the effective area of the optical switch array.

In contrast to the above, the optical switch array of Fig. 7 does not require the above-mentioned frame portions, and permits a substantial
15 reduction in the spacing between adjacent switching elements (for example, 10 μm or less). Accordingly, the optical switch structure of the Fig. 4 embodiment is extremely suitable for miniaturization of the switch array.

As described above, the optical switch of the second embodiment does not require the formation of the frame-like region of the substrate 21A
20 around each switching element as in the case of the optical switch 20 of the first embodiment depicted in Figs. 2A and 2B. Hence, the matrix-type optical switch array can be made particularly small. Besides, the miniaturization of the device structure further reduces the optical path, providing increased optical performance.

25 Moreover, this embodiment does not utilize such a substrate bonded structure as in the first embodiment, and hence it solves a problem such as a decrease in the positioning accuracy of the fixed electrode surface by bonding

or the influence of stress during bonding. Additionally, since no bonding step is involved, the manufacturing process can be simplified accordingly.

In the manufacturing process of the optical switch of this embodiment described above in respect of Figs. 5A to 5I, the polysilicon film 2d and the silicon substrate 21 are made reverse in conductivity type, a PN junction is formed in the substrate under its surface, and the polysilicon film 2b forming the movable electrode 24 and the elastic support portion 23 is connected to the polysilicon film 2d through the holes 2ah made in the SiO₂ protective film 2a as shown in Fig. 5C. As depicted in Figs. 8A through 8H, however, the SiO₂ protective film 2a may also be left as an insulating layer without making the holes 2ah in the step of Fig. 5C. That is, the polysilicon film 2b is formed all over the SiO₂ protective film 2a coated in the step of Fig. 8B and then exactly the same manufacturing steps of Figs. 8D to 8H as in Figs. 5E to 5I are carried out, by which the polysilicon film 2d and the SiO₂ film as the insulating layer 2a are left unremoved between the silicon substrate 21 and the stationary portions 22.

THIRD EMBODIMENT

As described previously, the present invention utilizes electrostatic drive for moving up and down by ON-OFF control of the voltage that is applied across the movable electrode and the fixed electrode, but the Fig. 2 embodiment requires a relatively large driving voltage. To reduce the driving voltage, it is necessary to make the elastic support portions 22a and 22b flexible by increasing their lengths and/or to increase the area of the movable electrode 24. To lengthen the elastic support portions 22 and to increase the area of the movable electrode 24 will inevitably make the optical switch large. This will surely incur undesirable marked upsizing of a large-

scale multi-input-multi-output optical switch array (a matrix optical switch) of optical switches arranged in an N-by-M matrix form. A description will be given of an optical switch improved to lower the driving voltage without making the switch large.

5 In this embodiment, a switch region 40 is chosen to be square which is defined by the envelope of the outer periphery of the region occupied by a movable electrode panel and elastic support portions. A movable electrode in the switch region 40, a mirror standing upright on the movable electrode, and the elastic support portions also in the switch region 40 are disposed
10 above a substrate that forms a fixed electrode opposite the movable electrode panel. The elastic support portions are coupled at one end to marginal edges of the movable electrode and at the other end to the substrate at marginal edges of the switch region 40. The elastic support portions are extended in zigzag between the opposite ends so that they occupy substantially the entire
15 switch region except those occupied by the movable electrode. With such a structure, it is possible to maximize the utilization of the electrode area in the switch region, decreasing the driving voltage accordingly.

Figs. 9A and 9B illustrate the optical switch according to the third embodiment of the present invention. A movable electrode panel 24 is
20 disposed above a square substrate 21A in parallel therewith and supported thereto by elastic support portions 23a to 23d. With a view to increasing its length, each of the support portions 23a to 23d is provided in the form of a zigzag beam in substantially the same plane as that of the movable electrode panel 24. The regions 31a to 31d occupied by the support portions 23a to
25 23d and the region by the movable electrode panel 24 (241 to 245) constitute a switch region substantially square in its entirety in this example, that is, a square switch region (which will hereinafter be referred to also as a switch

envelope) 40 whose one side is denoted by L4.

In this embodiment, the square movable electrode panel 24 has rectangular cut-out openings 32a to 32d in the central portions of its four sides and the elastic support portions 23a to 23d are disposed in the cut-out
5 openings 32a to 32d. The elastic support portions 23a to 23d have their outer ends connected to stationary portions 22a to 22d standing on the substrate 21A at mid-points of the respective sides of the movable electrode panel 24 and have their inner ends connected to the movable electrode panel
10 24 at mid-points of the inner ends of the cut-out openings 32a to 32d. The elastic support portions 23a to 23d are extended in zigzag form between their inner and outer ends across the entire regions of the cut-out openings 23a to 23d, respectively.

That is, the elastic support portions 23a to 23d are connected at their inner end to the mid-points of the respective sides of the central square
15 portion 245 of the movable electrode panel 24, extended outwardly in zigzag and connected to the stationary portions 22a to 22d, respectively. The peripheral square portions 241, 242 and 243 of the movable electrode panel 24 overlap four corners of the central square portion 245 alternately with the elastic support portions 23a to 23d. The width L2 of the zigzag elastic
20 support portion 23 is chosen to be a little smaller than the width W1 of the cut-out opening 32.

The elastic support portions 23a to 23d are connected to the upper ends of the stationary portions 22a to 22d on the substrate 21A, by which the movable electrode panel 24 is supported at a distance D1 from the substrate
25 21A. Because of their zigzag beam-like structure, the support portions 23a to 23d are elastic, and consequently, the movable electrode panel 24 can be displaced vertically to the substrate 21A. The substrate 21A, the movable

electrode panel 24, the support portions 23a to 23d and the stationary portions 22a to 22d can be formed as a one-piece structure.

The optical switch structure of this embodiment is common to the structure of the Fig. 2 embodiment except in the patterns of the movable
5 electrode panel 24 and the elastic support portions 23a to 23d. Accordingly, the optical switch of this embodiment can similarly be manufactured using, for example, the same manufacturing steps as those depicted in Figs. 3A to 3I. That is, the SiO₂ protective film 2a is formed all over the silicon substrate 21A as depicted in Fig. 3A (Step S1), and the protective film 2a is selectively
10 removed by photolithography to form therein the holes 2ah at those positions where to provide the stationary portions 22a to 22d as depicted in Fig. 3B (step S2). Then, the polysilicon layer 2c for forming the movable electrode panel 24 is deposited over the entire surface area of the substrate assembly as depicted in Fig. 3C (step S3), and the polysilicon layer 2b is patterned by
15 photolithography to form the movable electrode panel 24, the support portions 23a to 23d and the stationary portions 22a to 22d as depicted in Fig. 3D (step S4).

Next, the SiO₂ protective film 2c is formed over the entire surface area of the substrate assembly and all over the underside of the substrate 21A
20 as depicted in Fig. 3E (step S5), then the protective film 2c coated all over the underside of the substrate 21A is removed leaving only at its marginal portion as depicted in Fig. 3F, and the substrate 21A is etched away by the KOH solution with the remaining protective film 2c as a mask (step S6), by which the large opening 21a is formed in the portion of the substrate 21A
25 corresponding to the movable electrode panel 24, leaving the substrate 21A only at its marginal portion (Step S7). After this, the SiO₂ protective films 2a, 2b and 2c are removed by chemical etching to obtain a structure that

-19-

supports the movable electrode panel 24 above the frame-shaped substrate 21A as depicted in Fig. 3H (step S8). Next, as shown in Fig. 3I, the conductive silicon substrate 21B is fitted into the opening 21B of the substrate 21A from the side opposite to the movable electrode panel 24 and
5 bonded to the substrate 21A.

The mirror 25 is placed on the movable electrode panel 24 as shown in Figs. 9A and 9B by the same method as described previously in respect of the first embodiment. The mirror 25 is disposed, for instance, at 45 degrees to the direction of a line joining the resilient support portions 23a and 23b.
10 The mirror 25 may be formed integrally with the movable electrode panel 24, or separately formed and fixedly secured to the movable electrode panel 24. The movable electrode panel 24 and the elastic support portions 23a to 23d are formed, for example, 2 to 5 μm thick.

While this embodiment has been described to bond the conductive
15 substrate 21B to the frame-shaped substrate 21A as is the case with the first embodiment, it is also possible to form, as the fixed electrode, the low-floor portion 21L in the conductive substrate 21 as in the second embodiment depicted in Figs. 4A and 4B.

With the optical switch of this embodiment, too, the light beam La
20 from the incoming-side optical fiber 15A disposed at the left-hand side in Fig. 9A is incident on and reflected by the mirror 25 and then launched into the outgoing-side optical fiber 15C. When a voltage is applied across the movable electrode panel 24 and the substrate 21B to generate therebetween electrostatic force, the movable electrode panel 24 is displaced toward the
25 substrate 21B, allowing the light beam La from the optical fiber 15A to pass over the mirror 25 for incidence on the other outgoing-side optical fiber 15B disposed at the right-hand side in Fig. 9A. Thus, the light beam La from the

-20-

optical fiber 15A can selectively be switched between the optical fibers 15B and 15C by selective voltage application across the movable electrode panel 24 and the substrate 21B.

The optical switch of this embodiment has such dimensions as follows: 1000 μm for the length L4 of one side of the movable panel 24; 300 μm for the length L1 of each of the elastic support portions 23a to 23d; 200 μm for the width L2 of each zigzag support portion; 10 μm for the width W2 of the zigzag beam; 50 by 50 μm for a square cross-section of each of the stationary portions 22a to 22d; and 30 μm for the length L3 of each portion common to the central square portion 32a and each of the peripheral square portions 241 to 244.

Since the square movable electrode panel 24 is partly cut out to form therein openings and the elastic support portions 23a to 23d are disposed in the cut-out openings 32a to 32d, the area of the square movable electrode panel 24 can be made large. And since the elastic support portions 23a to 23d are each provided in the form of a zigzag beam, the beam is long relative to the length L1 of the support portion 23, making it possible to obtain a required amount of displacement with a small amount of electrostatic force. In the first embodiment shown in Figs. 2A and 2B, the movable electrode panel 24 is limited only to the central square portion 245, but in this embodiment the elastic support portions 23a to 23d and the peripheral square portions 241 to 244 are alternately disposed about the central square portion 245 and connected thereto--this provides a markedly increased area for the movable electrode panel 24. In the above examples of various numerical values, the area of the central square portion 245 is 300 by 300 μm^2 , and hence it can be said that the area of the movable electrode panel 24 is larger than in the Fig. 2 embodiment by the sum of the areas of the four peripheral

-21-

square portions 241 to 244, that is, by $4 \times 380 \times 380 \mu\text{m}$. Conversely, the cut-out openings are provided in the movable electrode panel 24 and the elastic support portions 23a to 23d are disposed in the cut-out openings, by which the entire structure is significantly reduced in size. A description will be given below of some examples of configurations of the movable electrode, each elastic support portion and each stationary portion.

While in the Fig. 9 embodiment the movable electrode panel 24 is supported at four points by the elastic support portions 23a to 23d at 90-degree intervals around the center of the panel 24, it may also be supported at two points by two elastic support portions 23a and 23b at 180-degree intervals as depicted in Fig. 10. In this case, the optical switch has such dimensions as listed below. The movable electrode pane 24 is a square panel (which have two rectangular cut-out openings 32a and 32b) measuring 1000 by 1000 μm ; the length L1 of each of the elastic support portions 23a and 23b is 300 μm ; the width L2 of each zigzag support portion is 200 μm ; the beam width W2 is 10 μm ; the stationary portions 22a and 22b each have a cross-section measuring 5 by 50 μm ; the distance L3 between the inner ends of the cut-out openings 32a and 32b is 300 μm ; and the width W1 of each of the cut-out openings 32a and 32b is 240 μm . Incidentally, in the Fig. 10 embodiment the substrate 21 has about the same configuration as the square configuration of the movable electrode panel 24. That is, the size of this optical switch in the horizontal plane is the same as the size of the movable electrode panel 24, and the outside shape of the optical switch is 100 by 100 μm in the afore-mentioned examples of various numerical values.

The movable electrode panel 24 may also be supported at one point as depicted in Fig. 11. That is, two elastic support portions 23a and 23b are disposed along one side of the movable electrode panel 24, and the elastic

-22-

support portions 23a and 23b have their far ends connected to the substrate 21 through the stationary portions 22a and 22b, respectively, and have their near ends interconnected, the interconnecting point being connected to the mid-point of the adjoining side of the movable electrode panel 24 through a
5 coupling portion 33. In other words, the movable electrode panel 24 is supported at one side by the elastic support portions 23a and 23b through the coupling portion 33. It can be said that the elastic support portions 23a and 23b are provided in the cut-out openings 32a and 32b formed by cutting out part of the square movable electrode panel 24 along one side thereof.

10 An example of numerical values in this case is as follows: 1000 μm for the longer side L4 of the movable electrode panel 24; 780 μm for its shorter side L5; 450 μm for the length L1 of each of the elastic support portions 23a and 23b; 200 μm for the width L2 of each zigzag support portion; 10 μm for the beam width W1; 115 μm for the length L3 of the
15 coupling portion 33; 10 μm for its width W2; and 50 by 50 μm for the cross-section of each of the stationary portions 22a and 22b. The outer dimension of the optical switch is 1000 by 1000 μm .

The movable electrode panel 24, though supported at one point, may also be formed as shown in Fig. 12. That is, the elastic support portions 23a
20 and 23b are disposed along two longer sides of a rectangular movable electrode panel 24, respectively; the elastic support portions 23a and 23b are connected at one end of the same side to the substrate 21 through the stationary portions 22a and 22b, respectively, and connected at the other end to opposite ends of a coupling beam 34, which is connected at its mid-point
25 to that of one shorter side of the movable electrode panel 24. Thus, the movable electrode panel 24 is surrounded, except one shorter side, by the elastic support portions 23a and 23b and the coupling beam 34. It can be

-23-

said that after two opposed marginal portions of a square movable electrode panel 24 are cut off, the support portions 23a and 23b are disposed there instead. With this structure, the lengths of the elastic support portions 23a and 23b can be increased.

5 Various dimensions in this instance are such, for example, as follows:
940 μm for the length L1 of each of the elastic support portions 23a and 23b,
200 μm for the length L2 of each zigzag support portion, 10 μm for the
beam width, 810 μm for the length L3 of the coupling beam 34, 10 μm for
its width W2, 50 by 50 μm for the cross-section of each of the stationary
10 portions 22a and 22b; 970 μm for the longer side L4 of the movable
electrode panel 24, and 560 μm for its shorter side L5. The outer
dimension of the optical switch is 1000 by 1000 μm .

As depicted in Fig. 13, the coupling beam 34 may be omitted, in
which case the elastic support portions 23a and 23b are coupled to both ends
15 of the shorter side of the movable electrode panel 24 through coupling
portions 33a and 33b, respectively. Various dimensions in this case are such,
for example, as follows: 940 μm for the length L1 of each of the resilient
support portions 23a and 23b; 200 μm for the width L2 of each zigzag
support portion; 10 μm for the beam width; 125 μm for the length L3 of
20 each of the coupling portions 33a and 33b; 10 μm for their widths W2; 50
by 50 μm for the cross-section of each of the stationary portions 22a and
22b; 1000 μm for the longer length L4 of the movable electrode panel 24;
and 560 μm for its shorter side L5. The outer dimension of the optical
switch is 1000 by 1000 μm .

25 Fig. 14 illustrates another modified form of the Fig. 11, in which the
elastic support portions 23c, 23d are provided in the movable electrode panel
24 on the side away from the resilient support portions 23a, 23b are coupled

-24-

to each other and the coupling portion is connected to the movable electrode panel 24. Thus, the movable electrode panel 24 is supported at two points.

Fig. 15 illustrates another embodiment of the present invention, in which a square movable electrode panel 24 is disposed at an angle of 45 degrees to a square optical-switch outside shape or envelope 40 with its vertexes at the mid-points of respective sides of the envelope 40 and the support portions 23a to 23d are connected at one end to the mid-points of respective sides of the movable electrode panel 24 and at the other end to the stationary portions 22a to 22d formed upright on the substrate 21 at four corners of the optical switch envelope 40. The width of zigzag configuration of each of the support portions 23a to 23d increases toward the movable electrode panel 24 but decreases toward the stationary portion, thus making effective use of empty space between the movable electrode panel 24 and the optical switch envelope 40. In this instance, too, it can be said that four corner portions of an electrode of the same size as the optical switch envelope 40 are cut away to form the movable electrode panel 24 centrally thereof and the support portions 23a to 23d are provided in the cut-out openings.

It is also possible to employ such a structure as depicted in Fig. 16 in which the movable electrode panel 24 has about the same outside shape as that of the optical switch envelope 40 and has rectangular cut-out openings 32a to 32d extending from the four corners of the electrode panel 24 toward the center thereof, and the support portions 23a and 23d are disposed in the cut-out openings 32a to 32d, respectively, and have their inner ends connected to the movable electrode panel 24 and have their outer ends connected to the substrate 21 through the stationary portions 22a to 22d.

In an embodiment depicted in Fig. 17, a square movable electrode

-25-

panel 24 is disposed in a square switch region centrally thereof and the elastic electrode panel 24 are extended in parallel to its sides in the same direction of rotation and turned or bent 90 degrees in the same direction at the next corners and then each extended outside the inner support portion parallel to the adjoining side and projected out of the switch region 40, the projected ends being fixed to the stationary portions 22a through 22d. With this structure, the elastic support portions 23a to 23d each have only one bend and form a long support portion. In the case of the same length, the elastic constant increases with an increase in the number of bends. Accordingly, the structure of this embodiment provides support portions of low elastic constant and hence permits driving the optical switch at low voltage.

While the embodiments described above have been described to use the conductive polysilicon film to form the movable electrode and elastic support portions in one piece, other conductive films as of metal may also be used. Furthermore, the above embodiment have been described to use the micro mirror 25 for switching the optical path of the incoming light beam, a micro prism may also be used as such an optical path switching element in place of the micro mirror.

Fig. 18 schematically illustrates an example of an optical switch module actually formed using the optical switch according to the present invention. The optical switch 20 employs, in the Fig. 4 embodiment, the structures of the movable conductive panel 24 (241 to 245), the elastic support portions 23a to 23d and the stationary portions 22a and 22d depicted in Fig. 9 (none of these reference numerals being shown for simplicity sake). The optical switch 20 is mounted on a rectangular glass substrate 10. Attached to three sides of the glass substrate 10 are V-groove blocks 11A, 11B and 11C, and the incoming-side optical fiber 15A and two outgoing-side

-26-

optical fibers 15B and 15C are received in the V-grooves with their optical axes kept in alignment with the micro mirror 25 of the optical switch 20. The movable electrode panel 24 and the fixed electrode are connected by wire bonding to terminal electrodes 42a and 42b on the glass substrate 10, and a driving voltage is applied across the terminal electrodes 42a and 42b from a driving voltage source 43.

On the optical switch 20 there are placed plane micro lenses (PMLs) 41A, 41B and 41C along its three marginal edges. These PMLs 41A, 41B and 41C are high enough to stay in the optical path even when the movable electrode panel 24 is displaced to a maximum. The incident light from the optical fiber 15A is reduced in diameter by the PML 41A down to a minimum at the position of the mirror 25 and then spreads again. When the mirror 25 is displaced by the application of the driving voltage, the light beam from the optical fiber 15A passes through the PML 41A and is reduced again in diameter by the PML 41B, thereafter being launched into the optical fiber 15B. With no driving voltage applied, the light beam reflected by the mirror 25 is reduced again in diameter by the PML 41C and then launched into the optical fiber 15C. In our experiments, the light beam emitted from the optical fiber 15A spread thick about $140 \mu\text{m}$ in diameter until it impinged on the PML 41A but reduced down to $33 \mu\text{m}$ until it reached the mirror 25 from the PML 41A. The mirror 25 was $45 \mu\text{m}$ in height.

Fig. 19 is a graph showing measured values of the minimum driving voltage in the optical switch module of Fig. 18 with respect to variations in the size of the movable electrode (the length of its one side) using the thickness of the elastic support portion 23 as a parameter. The wavelength of light used is $1.55 \mu\text{m}$. The solid lines indicate calculated values by simulation. The minimum driving voltage decreases with a decrease in the

thickness of the elastic support portion or an increase in the size of the movable electrode. The measured results shown in Fig. 19 suggest that an optical switch of a driving voltage below 5V could be obtained, and indicate that an ultraminiature optical switch with a 600- μ m movable electrode size
5 could be realized if the thickness of the elastic support portion would be 0.5 μ m, for instance.

Fig. 20 is a graph showing the relationships between the minimum driving voltages of optical switches having elastic support portions of various thicknesses and movable electrode sizes and their power consumption. As
10 will be seen from the graph, it is possible to produce a power-saving optical switch whose driving voltage is lower than 5 V and power consumption is less than several μ W. Accordingly, the optical switch of the present invention is suitable for use in optical networks. In our experiments the
15 optical switch was driven by ON-OFF control of DC voltage, but electrostatic attractive force between electrodes can similarly be obtained even with AC driving voltage.

EFFECT OF THE INVENTION

According to a first aspect of the present invention, since electrostatic
20 drive is used to displace the micro mirror, the optical switch can be made far smaller than in the past and hence is suitable for use in optical networks.

According to a second aspect of the present invention, the surface region of the conductive substrate opposite the movable electrode panel and the elastic support portion is etched away to form the low-floor portion that is
25 used as the fixed electrode. This eliminates the necessity for making an opening in the substrate as in the prior art and hence permits fabrication of a matrix optical switch with no wasted space.

-28-

According to a third aspect of the present invention, since the region where the movable electrode panel and the support portions is square, the optical switch can be miniaturized and the area of the movable electrode panel can be made large--this allows effective use of the area of the outside shape of the optical switch structure and permits low-voltage driving of the switch.

It will be apparent that many modifications and variations may be effected without departing from the scope of the novel concepts of the present invention.

10

15

20

25

-29-

WHAT IS CLAIMED IS:

1. An optical switch comprising:

substrate means;

fixed electrode means fixedly secured to said substrate means with the surface of said fixed electrode means held lower than and in parallel to the surface of said substrate means;

movable electrode means disposed opposite to said fixed electrode means in spaced relation thereto;

elastic support means for coupling said movable electrode means and said substrate means and for elastically supporting said movable electrode means so that said movable electrode means can be displaced vertically to said fixed electrode means; and

optical path switching means provided on the surface of said movable electrode means opposite said fixed electrode means and having a light receiving surface perpendicular to said surface of said movable electrode means;

wherein, by ON-OFF control of voltage application across said movable electrode means and said fixed electrode means, said movable electrode means is displaced toward said fixed electrode means and returned to its normal position to selectively switch the optical path of an incident light means by said optical path switching means.

2. The optical switch of claim 1, wherein said elastic support means has a plurality of elastic support portions for coupling a plurality of different marginal portions of said movable electrode means to said substrate means.

3. The optical switch of claim 1, wherein said elastic support means has fixing means of increased thickness coupled to said substrate means, for supporting said elastic support means and said movable electrode means above the surface of said substrate means.

-30-

4. The optical switch of claim 1, wherein: said substrate means has an opening facing a region containing at least said movable electrode means and said elastic support means; and said fixed electrode means includes a conductive substrate secured to said substrate means from the side opposite said movable electrode means in a manner to fill said opening, said conductive substrate having, as a fixed electrode, its surface opposed to said movable electrode means in spaced relationship thereto.

5. The optical switch of claim 1, 2, 3, or 4, wherein said substrate means is a silicon substrate.

6. The optical switch of claim 5, wherein said movable electrode means and an elastic support means are integrally formed of the same material.

7. The optical switch of claim 6, wherein said movable electrode means and said elastic support means are integrally formed by a polysilicon film.

8. The optical switch of claim 1, wherein said substrate means is a conductive substrate, said conductive substrate having, as said fixed electrode means, a low-floor portion made lower than the substrate surface over an area facing said movable electrode means and said elastic support means.

9. The optical switch of claim 8, wherein said elastic support means has fixing means of increased thickness coupled to said substrate means, for supporting said elastic support means and said movable electrode means above the surface of said substrate means.

10. The optical switch of claim 9, wherein said movable electrode means and an elastic support means are integrally formed of the same material.

11. The optical switch of claim 10, wherein: said conductive substrate

-31-

is a silicon substrate of one of P and N conductivity types; said movable electrode means and said elastic support means are integrally formed by a polysilicon film of the other conductivity type; and a PN junction is formed in said silicon substrate under the surface thereof at a portion coupled to said elastic support means.

12. The optical switch of claim 8, wherein said elastic support means includes an insulating layer coupled to said substrate means, for electrically insulating said substrate means and said elastic support means.

13. The optical switch of claim 9 or 11, wherein said movable electrode means has a plurality of through holes.

14. The optical switch of claim 1, 4, or 8, wherein said elastic support means has two elastic support portions extending in opposite directions from two opposite sides of said movable electrode means.

15. The optical switch of claim 14, wherein said two elastic support portions are each in the shape of a rectangular frame and coupled substantially at the centers of its two opposed sides to said movable electrode means and said substrate means, respectively.

16. The optical switch of claim 1, 4, or 8, wherein a substantially rectangular switch region is defined by an envelope of a periphery of a region occupied by said movable electrode means and said elastic support means.

17. The optical switch of claim 16, wherein: said movable electrode means has a substantially rectangular central electrode portion disposed inside said switch region concentrically therewith with its respective sides extending in parallel with those of said switch region, and four substantially rectangular peripheral electrode portions each having a first corner portion overlapping one of four corner portions of said central electrode portion and a

-32-

second corner portion diagonally opposite said first corner portion; and said elastic support means has four elastic support portions each extending in zigzag form across the entire area of a rectangular region defined between said peripheral electrode portions adjacent thereto and coupled at one end to said central electrode portion and at the other end to said substrate means at a marginal edge of said switch region.

18. The optical switch of claim 16, wherein said elastic support means includes two elastic support portions each extending in zigzag form across the entire area of one of two substantially rectangular regions of the same size extended toward each other from two opposite sides of said switch region and coupled at one end to said movable electrode means and at the other end to said substrate means.

19. The optical switch of claim 18, wherein: said movable electrode means is a rectangle occupying one of two regions divided from said switch region along a straight line parallel to one side thereof; said two rectangular regions are defined to occupy the other region and extend along the same side of said rectangular region; and said one end of each of said two elastic support portions is coupled to said movable electrode means at the same point.

20. The optical switch of claim 16, wherein: said movable electrode means is a rectangle occupying a central one of three regions divided from said switch region along two straight lines parallel to one side thereof; and said elastic support means is extended in zigzag form across the entire area of said rectangular region at both sides of said movable electrode means.

21. The optical switch of claim 20, wherein one end of said elastic support means is coupled to said substrate means on one of shorter sides of said rectangular region and the other end of said each elastic support portion

-33-

is extended from the other shorter side along a side at right angles to said one side of said switch region and coupled to said movable electrode means on its shorter side.

22. The optical switch of claim 20, wherein said extended elastic support means are coupled at one end to said substrate means at one of shorter sides of said rectangle and at the other end to two corner portions of said movable electrode means on the other shorter side.

23. The optical switch of claim 20, wherein said extended elastic support means is coupled at both ends to said substrate means on both shorter sides of said rectangle and coupled to said movable electrode means on the longer side of said rectangle substantially at the center thereof.

24. The optical switch of claim 16, wherein: said switch region is substantially square; said movable electrode means has substantially a square form with its vertexes at the centers of respective sides of said switch region; said elastic support means is coupled at one end to each side of said movable electrode means, extended in zigzag form across the entire area of each of four triangular regions outside said movable electrode means in said switch region and coupled to said substrate means at that one of four corner portions of said switch region which is opposite said each side.

25. The optical switch of claim 16, wherein: said switch region is substantially square; said elastic support means is coupled to said substrate means at each corner portion of said switch region, extended in zigzag form across the entire area of substantially a rectangular support region extended from said each corner portion of said switch region toward the center thereof and coupled to said movable electrode means on the side of said support region away from said each corner portion.

26. The optical switch of claim 16, wherein: said movable electrode

-34-

means has a rectangular form having sides parallel to respective sides of said switch means; and said elastic support means has four beam-like elastic support portions coupled at one end to respective corner portions of said movable electrode means, extended in the same direction of rotation at least one of respective sides of said movable electrode means in parallel thereto and coupled at the other end to said substrate means.

27. A method for making an optical switch in which an optical path switching element mounted on a movable electrode is displaced to switch the optical path of an incident light beam, said method comprising the steps of:

(a) forming on a silicon substrate a pattern containing a movable electrode portion and an elastic support portion coupled thereto by a conductive silicon film;

(b) making an opening by etching away that region of said silicon substrate which is opposite to at least said movable electrode portion and said elastic support portion;

(c) attaching a conductive substrate to the underside of said silicon substrate so that one surface region of said conductive substrate serves as a fixed electrode opposite but spaced apart from at least said movable electrode portion in said opening; and

(d) forming said optical path switching element on said movable electrode portion.

28. The method of claim 27, wherein said step (a) comprises the steps of:

(a-1) forming an SiO₂ film over the entire surface area of said silicon substrate and making a hole in said SiO₂ film at the position where to couple said elastic support portion to said silicon substrate;

(a-2) forming a polysilicon film all over said SiO₂ film; and

-35-

(a-3) patterning said polysilicon film by etching to form said pattern containing said movable electrode portion and said elastic support portion.

29. The method of claim 28, wherein said step (b) comprises the steps of:

(b-1) forming an SiO₂ protective film all over the surface and underside of said silicon substrate;

(b-2) forming said opening in said silicon substrate by etching away said SiO₂ protective film on that region of the underside of said silicon substrate which is opposite said movable electrode portion and said support portion; and

(b-3) removing the entire remaining protective film.

30. The method of claim 27, 28, or 29, wherein said optical switching element is a micro mirror, and said step (d) comprises the steps of:

(d-1) forming a plating seed metal land on said movable electrode portion at the position where to form said micro mirror;

(d-2) forming a resist layer over the entire surface area of said silicon substrate and exposing part of said seed metal land by making a hole of the same shape as said micro mirror in said resist layer at the position where to form said micro mirror;

(d-3) filling said hole with metal for said micro mirror by plating; and

(d-4) removing said resist layer.

31. A method for making an optical switch in which an optical path switching element mounted on a movable electrode is displaced to switch the optical path of an incident light beam, said method comprising the steps of:

(a) forming a first polysilicon film over the entire surface area of a conductive silicon substrate;

(b) forming a pattern, which contains a movable electrode portion and

-36-

an elastic support portion coupled to said movable electrode portion in spaced and parallel relation thereto, all over said first polysilicon film by a second polysilicon film of a preselected conductivity type;

(c) forming a low-floor portion as a fixed electrode by etching away that surface region of said conductive silicon substrate which is opposite at least said movable electrode portion and said elastic support portion; and

(d) forming on said optical path switching element on said movable electrode portion.

32. The method of claim 31, wherein the conductivity type of said first polysilicon film is opposite to that of said conductive substrate, and said step (b) comprises the steps of:

(b-1) forming an SiO₂ film all over said first polysilicon film and making holes in said SiO₂ film at positions where to couple said elastic support portion to said conductive substrate, said holes extending down to said first polysilicon film;

(b-2) forming said second polysilicon film all over said SiO₂ film; and

(b-3) selectively etching away said second polysilicon film to form a pattern having a plurality of through holes and containing said movable electrode portion and said elastic support portion.

33. The method of claim 32, wherein said step (c) comprises the steps of:

(c-1) forming an SiO₂ protective film over the entire areas of the surface and underside of said conductive silicon substrate;

(c-2) forming apertures which extend through said SiO₂ protective film and down to said first polysilicon film inside said through holes;

(c-3) etching away said first polysilicon film on that surface region of

-37-

said conductive substrate opposite said movable electrode portion and said elastic support portion and further etching away said surface region of said conductive substrate to a predetermined depth to form said low-floor portion; and

(c-4) removing said SiO₂ protective film.

34. The method of claim 31, wherein said step (b) comprises the steps of:

(b-1) forming an SiO₂ film all over said first polysilicon ;

(b-2) forming said second polysilicon film all over said SiO₂ film; and

(b-3) selectively etching away said second polysilicon film to form a pattern having a plurality of through holes and containing said movable electrode portion and said elastic support portion.

35. The method of claim 34, wherein said step (c) comprises the steps of:

(c-1) forming an SiO₂ protective film over the entire areas of the surface and underside of said conductive silicon substrate;

(c-2) forming apertures which extend through said SiO₂ protective film and down to said first polysilicon film inside said through holes;

(c-3) etching away said first polysilicon film on that surface region of said conductive substrate opposite said movable electrode portion and said elastic support portion and further etching away said surface region of said conductive substrate to a predetermined depth to form said low-floor portion; and

(c-4) removing said SiO₂ protective film.

36. The method of claim 31, 32, or 34, wherein said optical switching element is a micro mirror, and said step (d) comprises the steps of:

(d-1) forming a plating seed metal land on said movable electrode

-38-

portion at the position where to form said micro mirror;

(d-2) forming a resist layer over the entire surface area of said conductive silicon substrate and exposing part of said seed metal land by making a hole of the same shape as said micro mirror in said resist layer at the position where to form said micro mirror;

(d-3) filling said hole with metal for said micro mirror by plating; and

(d-4) removing said resist layer.

FIG.2A

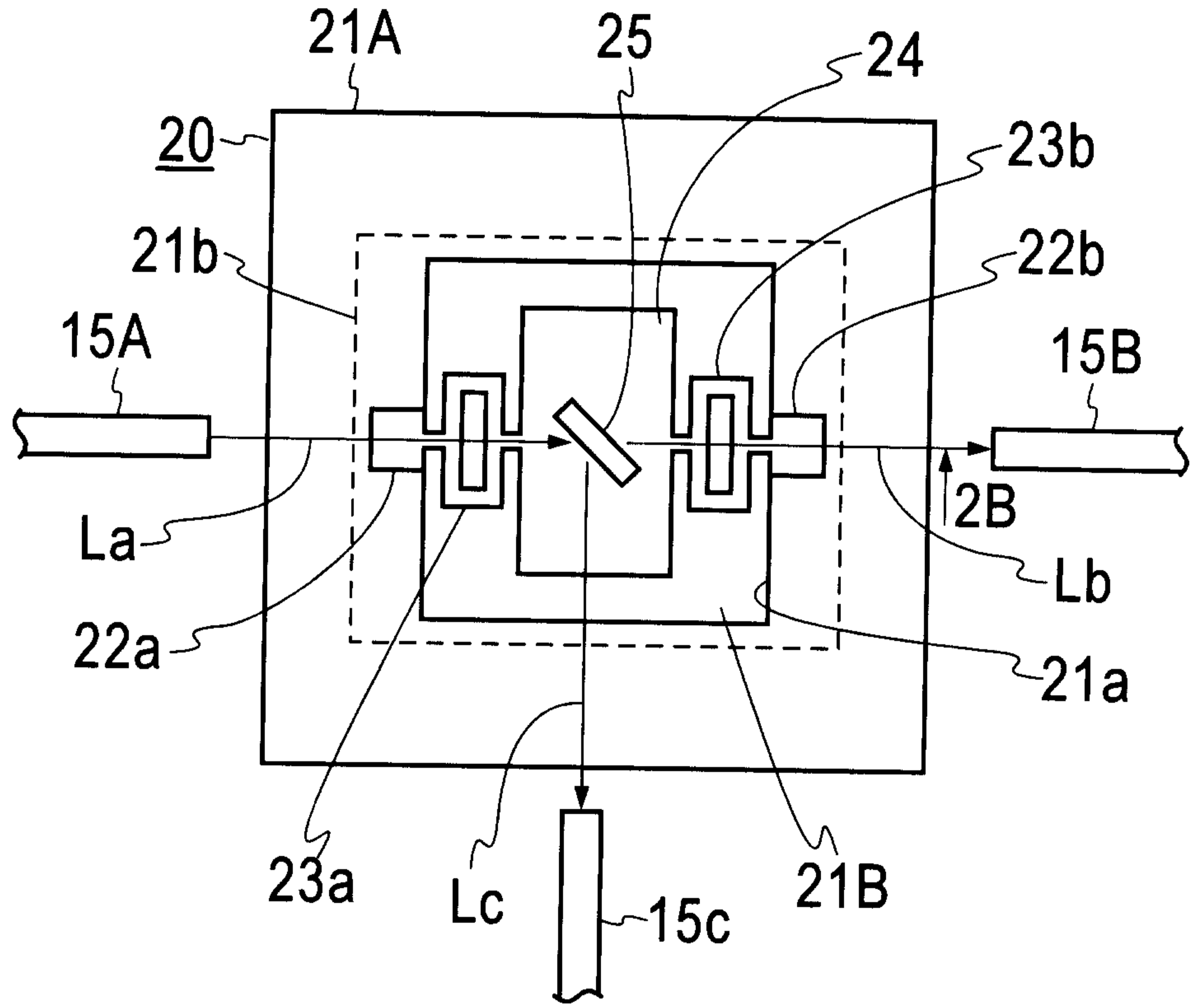

FIG.2B

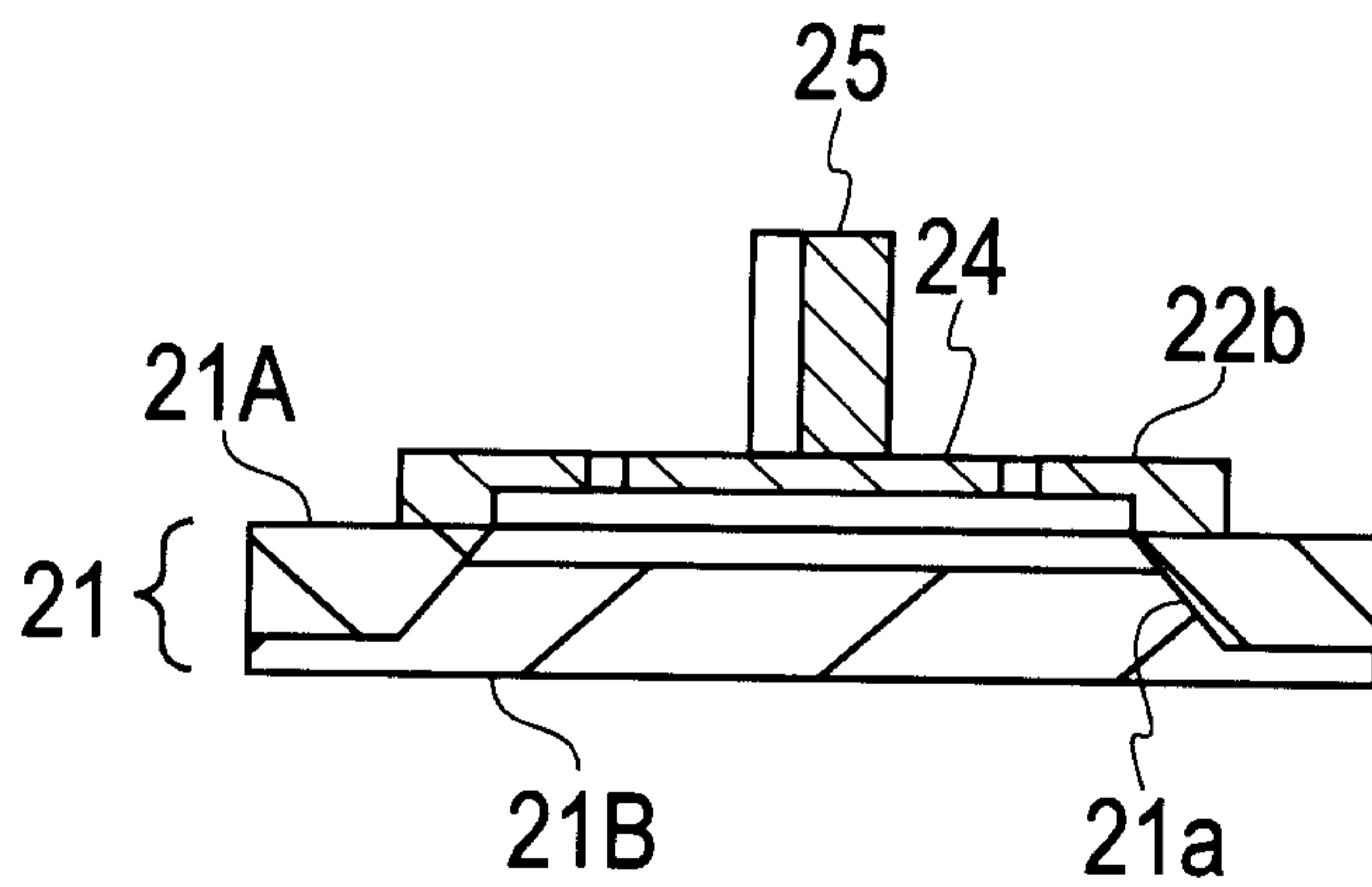

FIG.3A

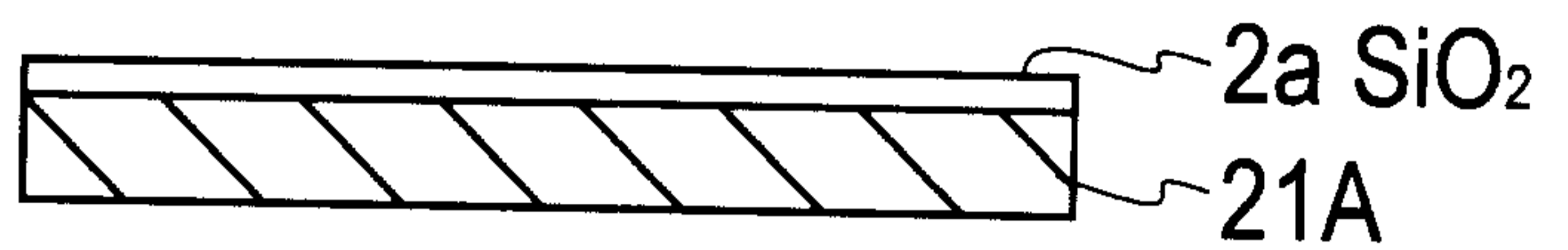

FIG.3B

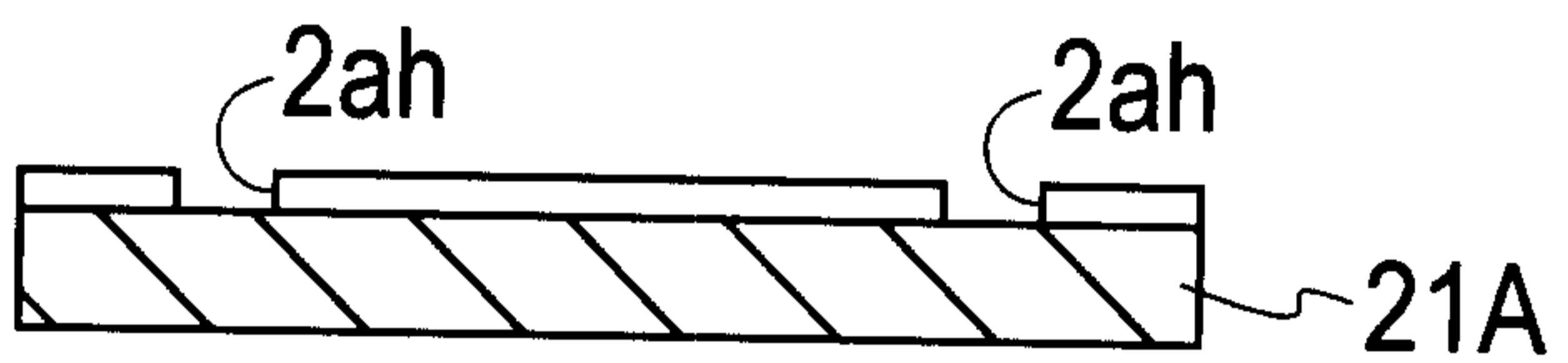

FIG.3C



FIG.3D

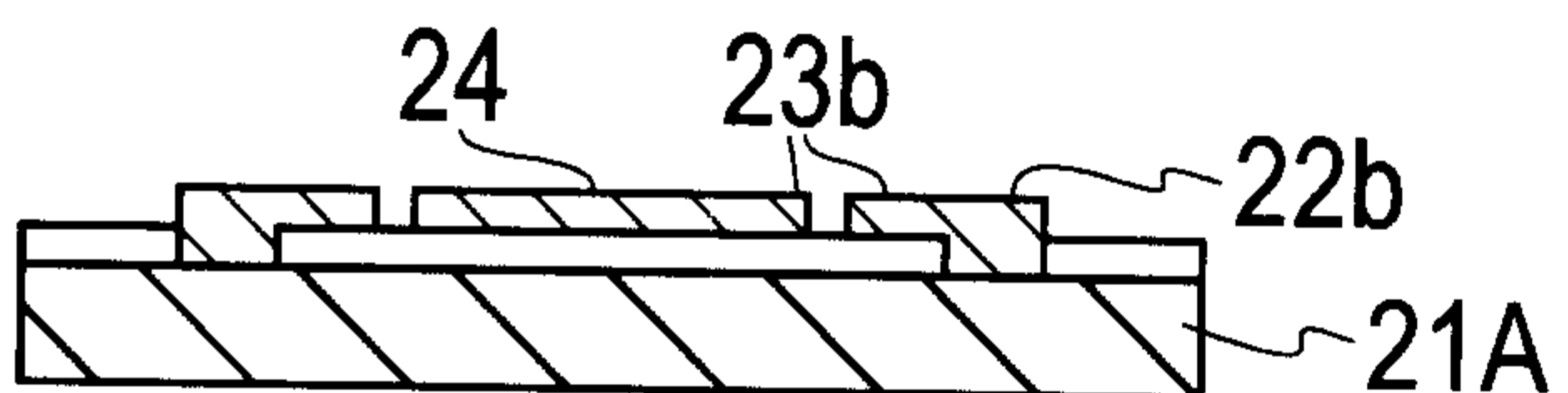

FIG.3E

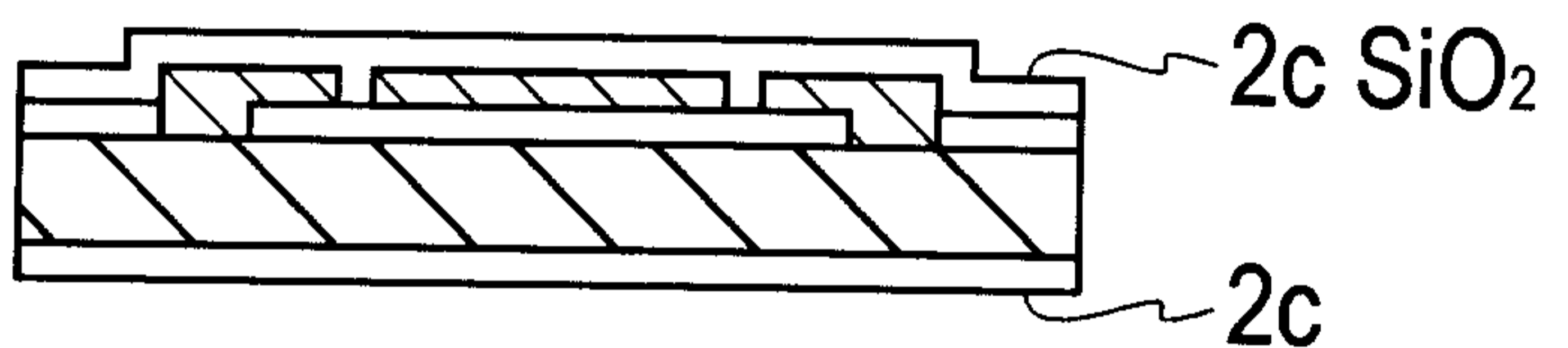

FIG.3F

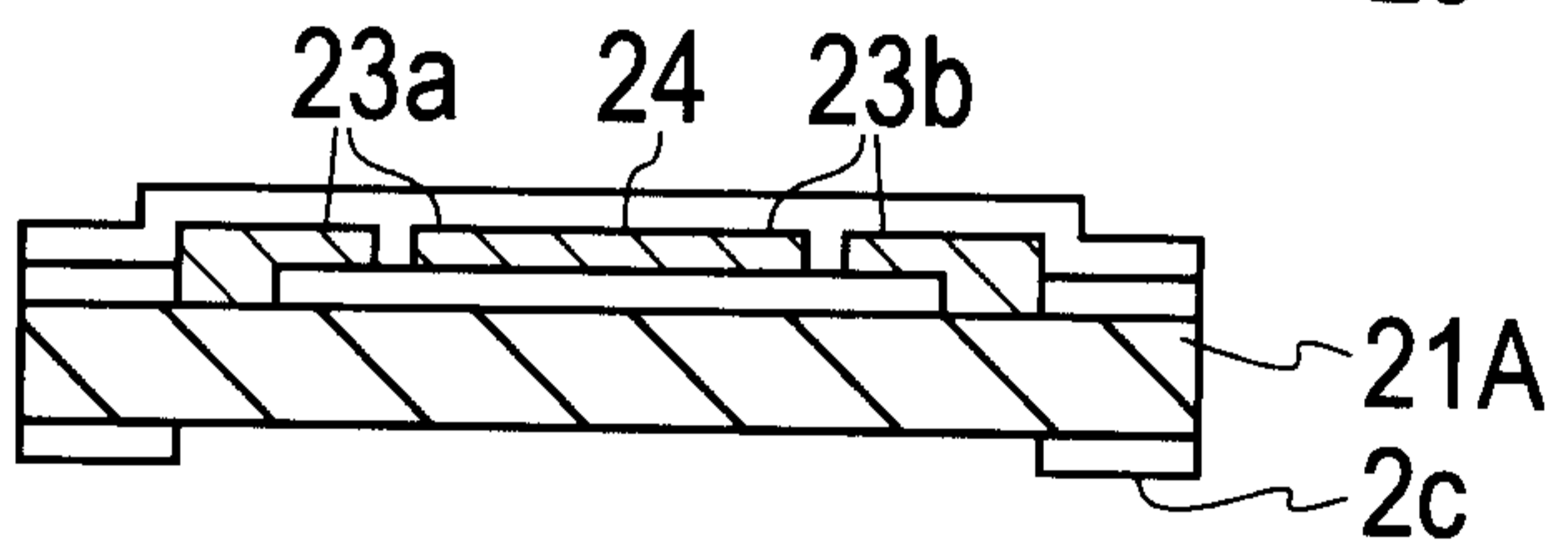

FIG.3G

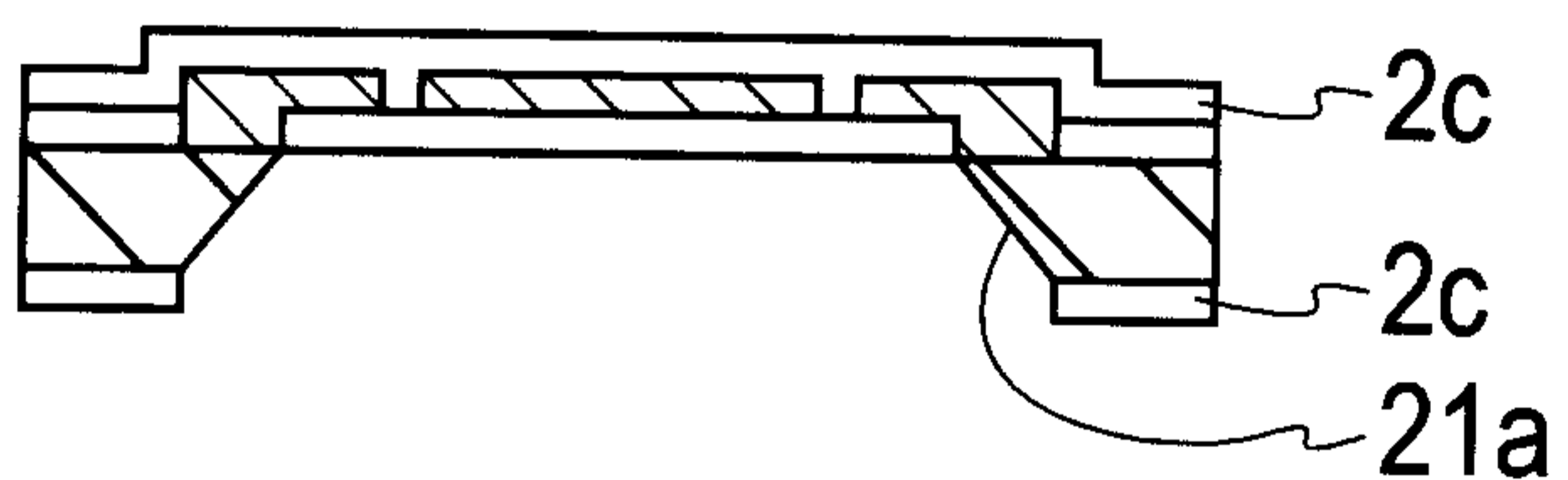

FIG.3H

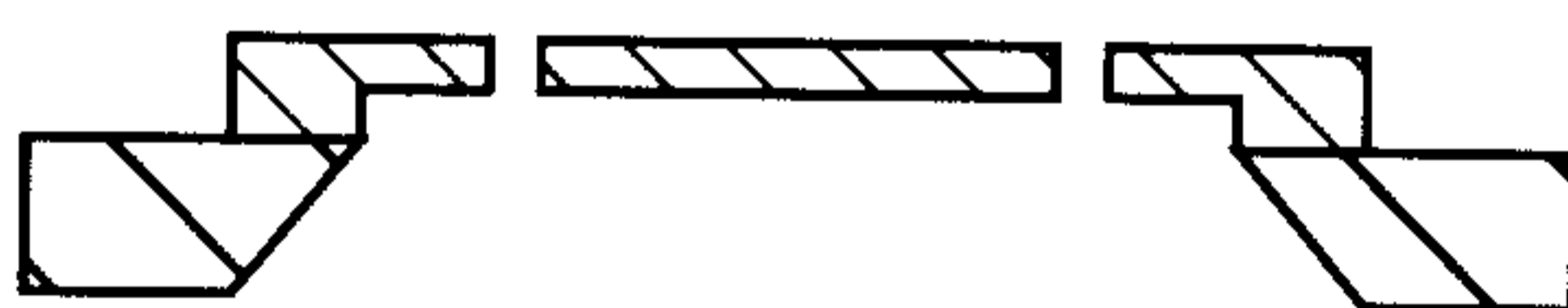

FIG.3 I

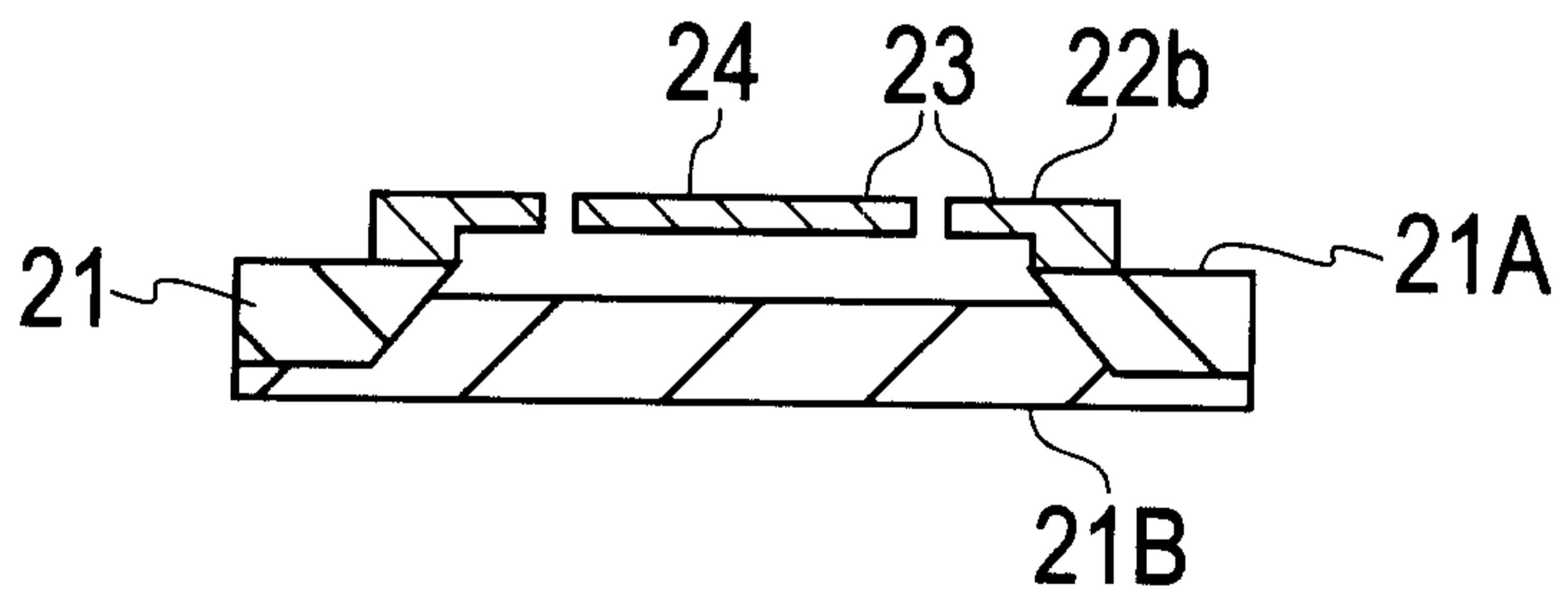

FIG.4A

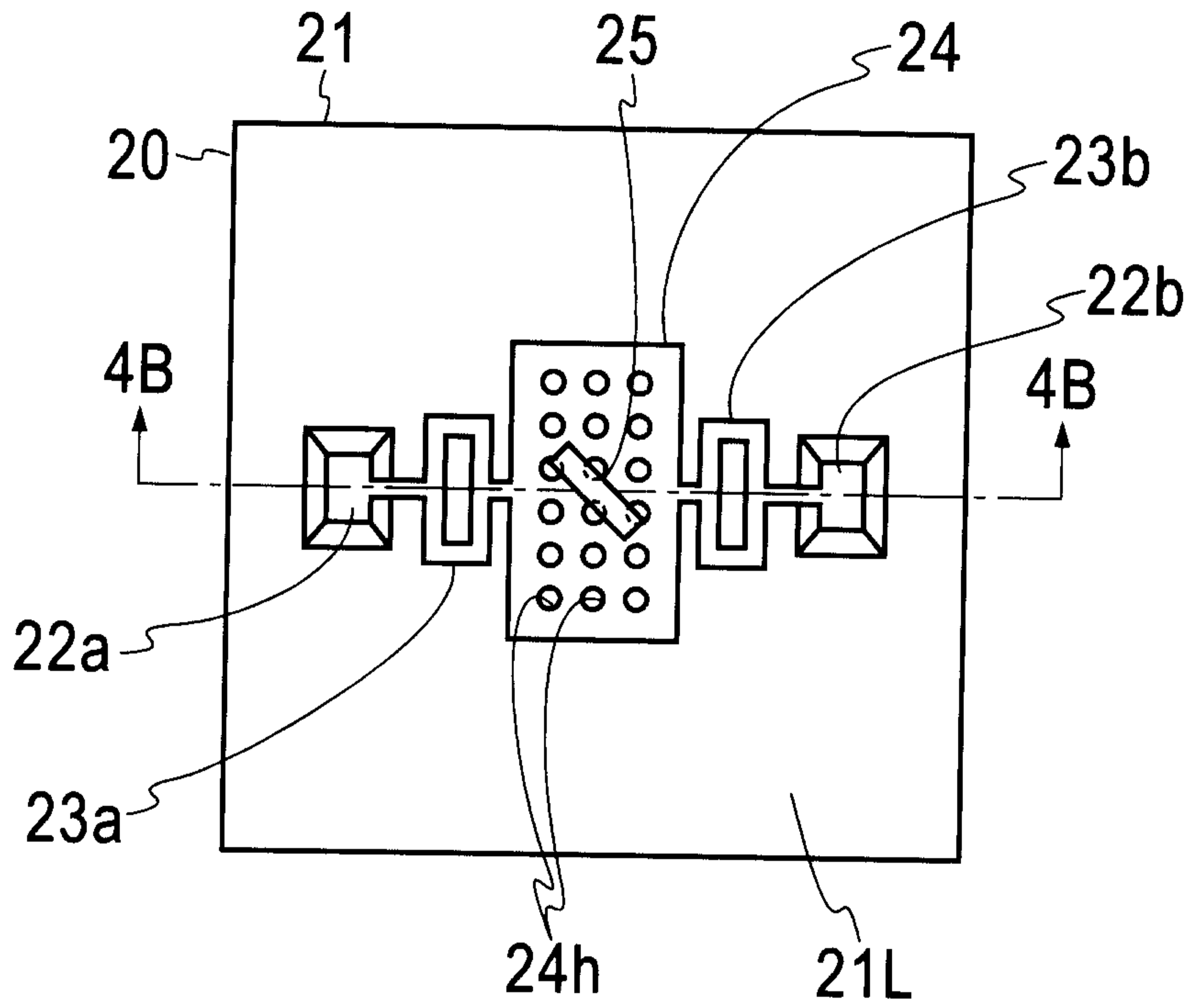

FIG.4B

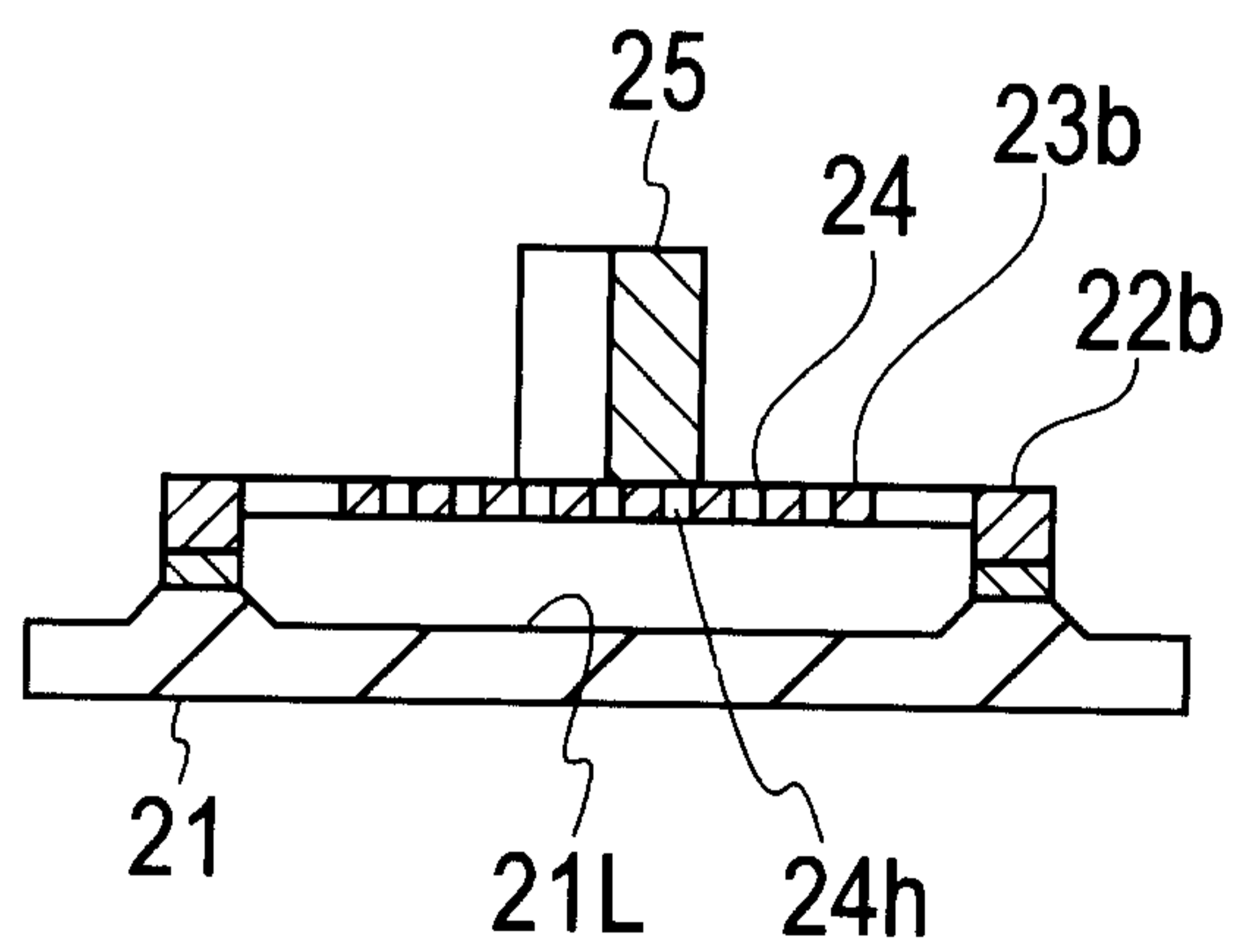

FIG.5A

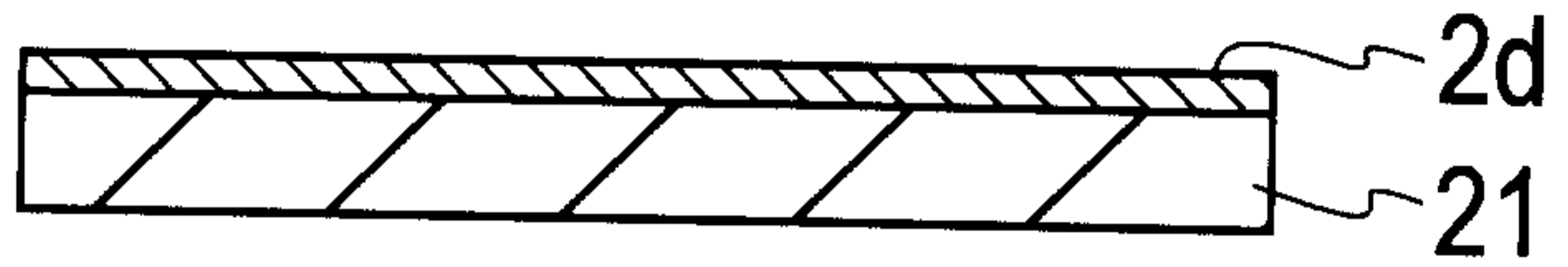

FIG.5B

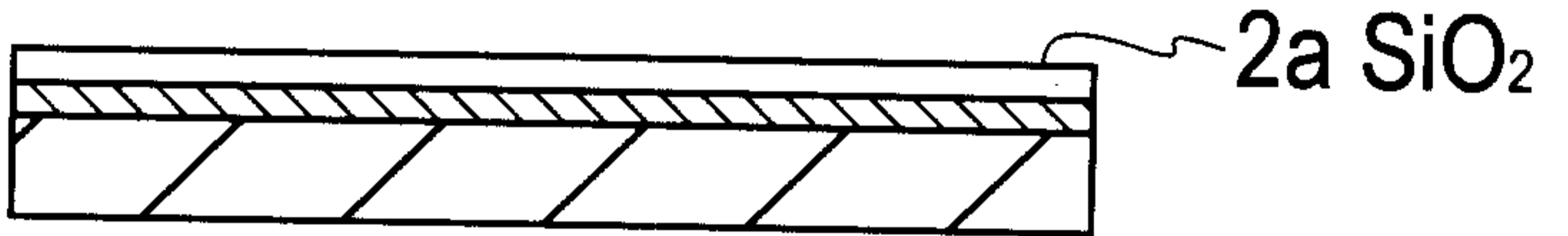

FIG.5C

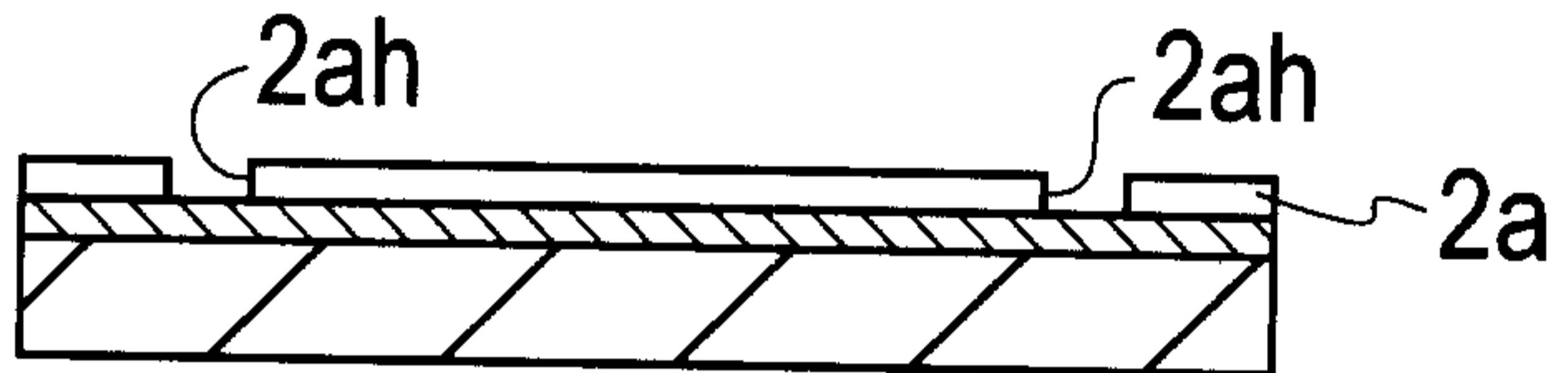

FIG.5D

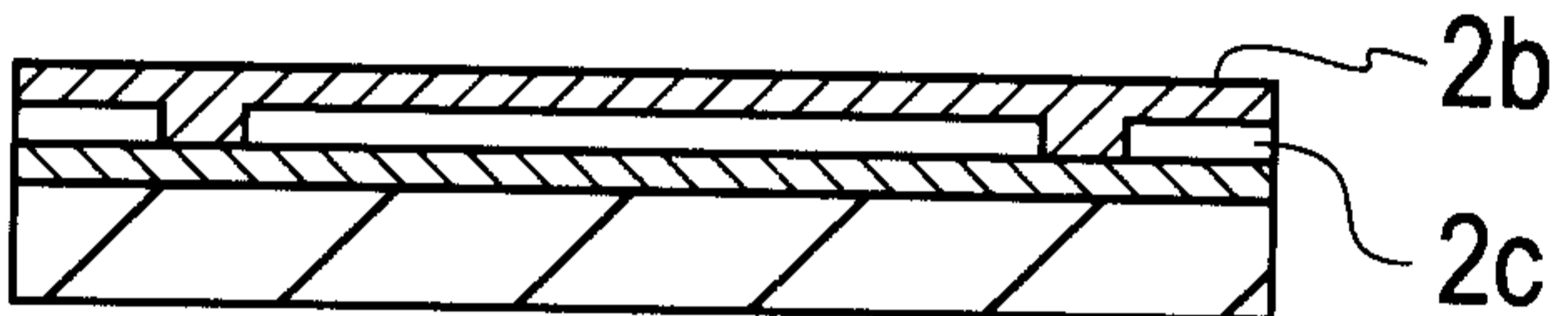

FIG.5E

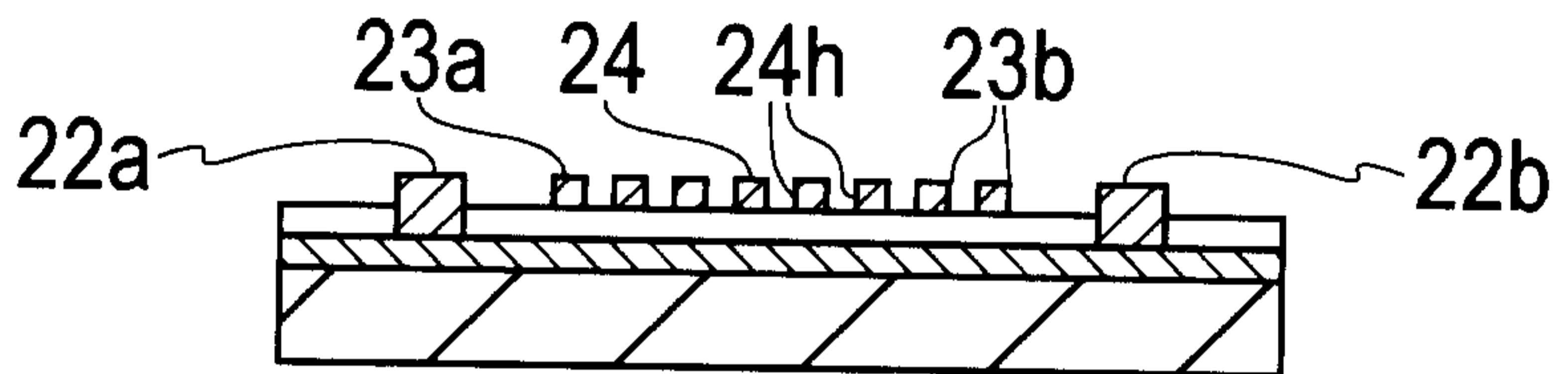

FIG.5F

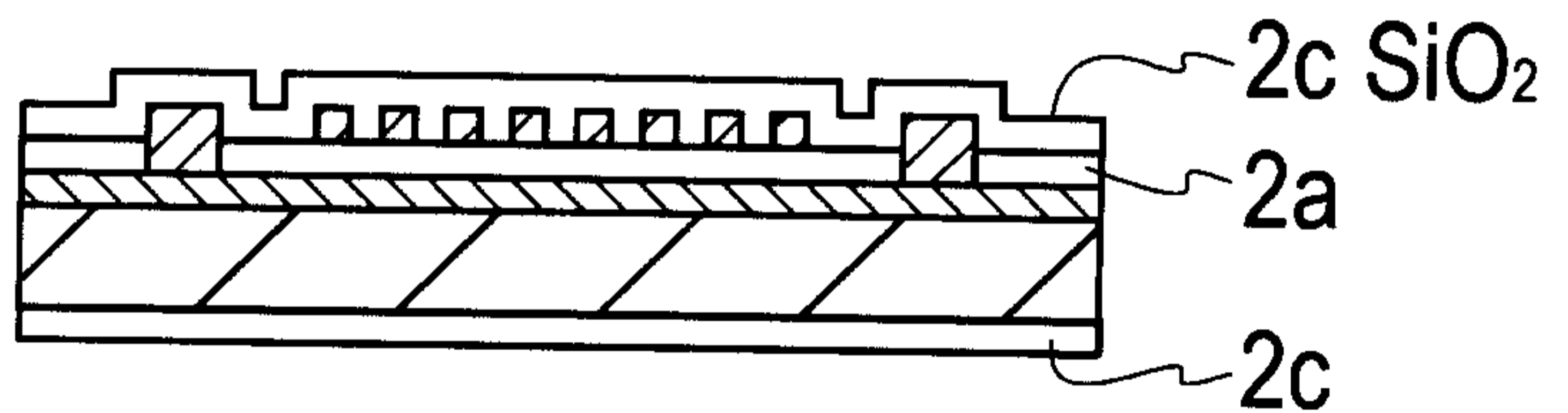

FIG.5G

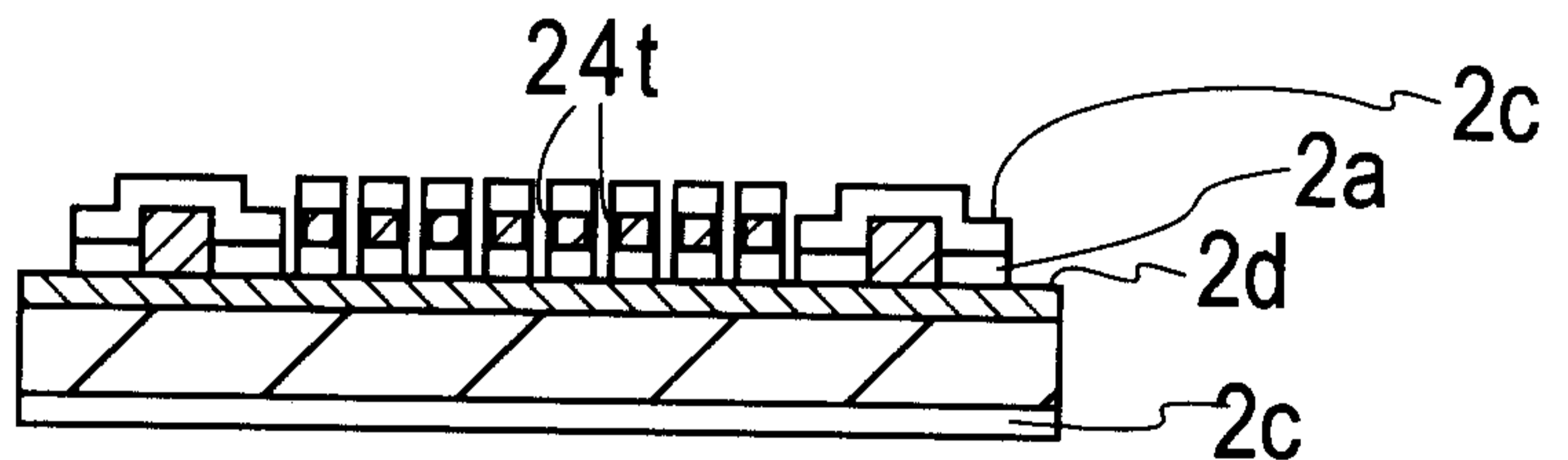

FIG.5H

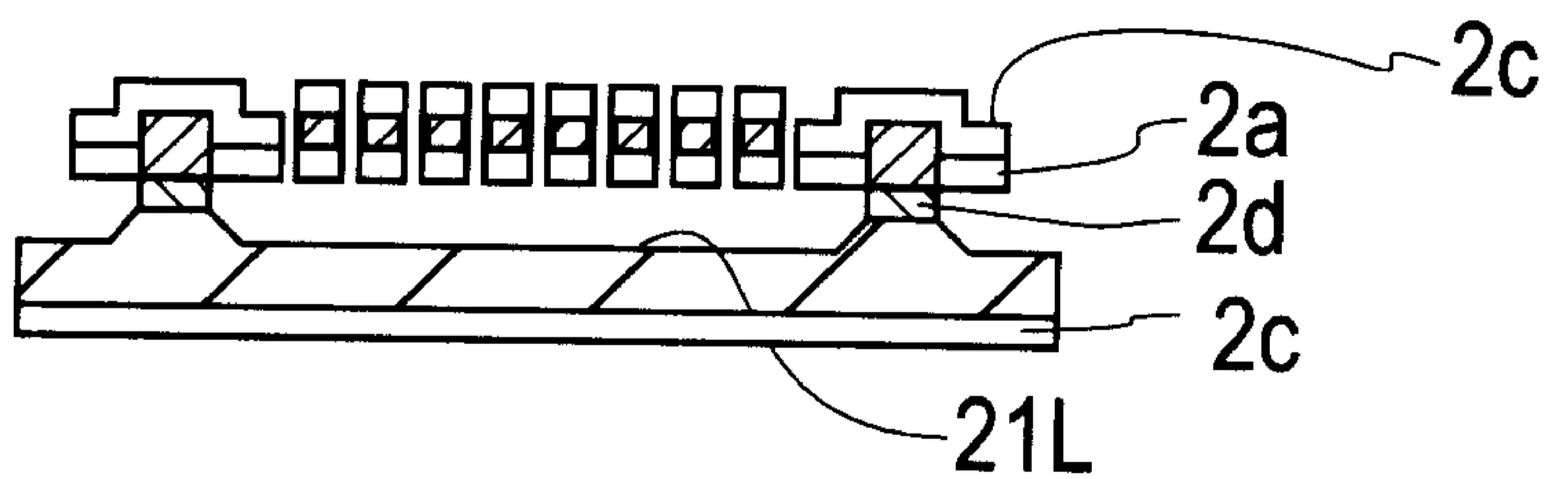

FIG.5 I

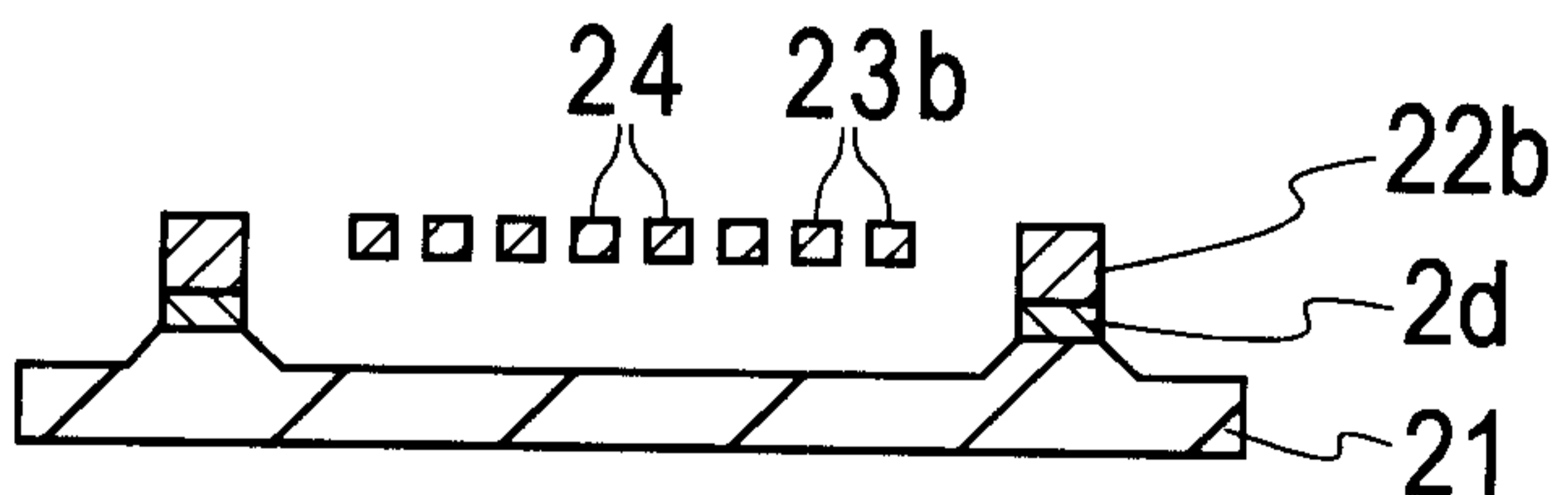

FIG.6

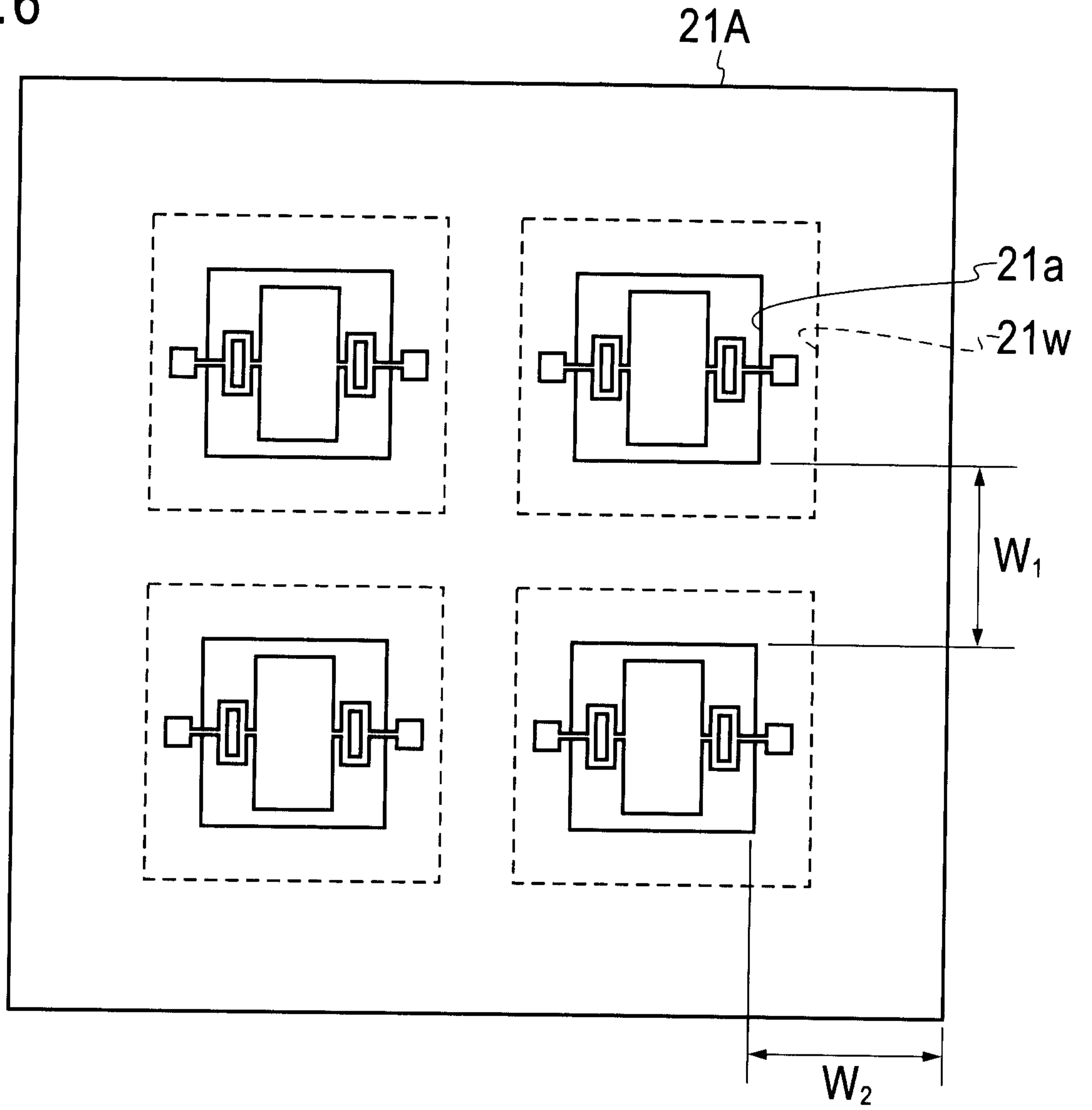

FIG.7

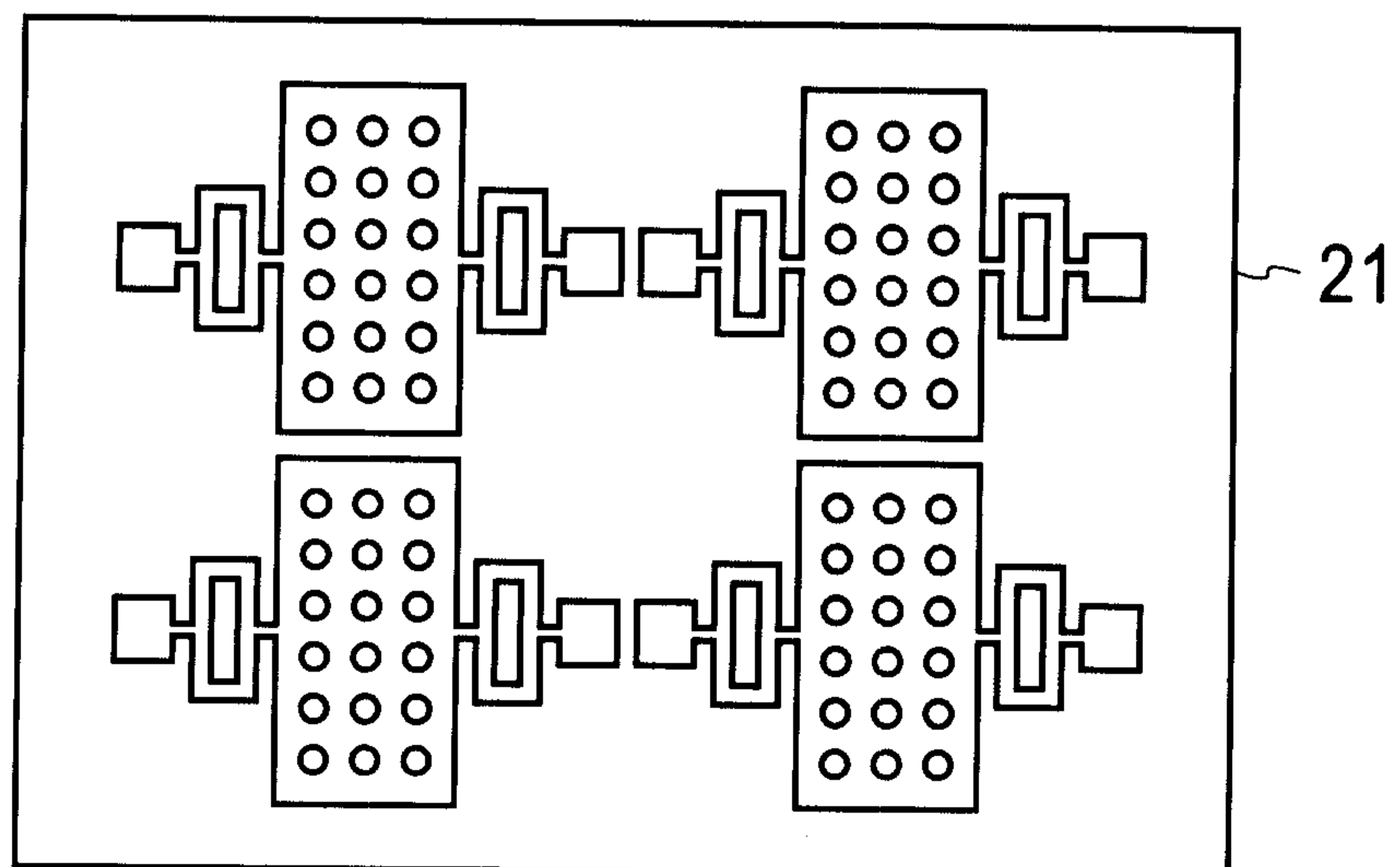

FIG.8A

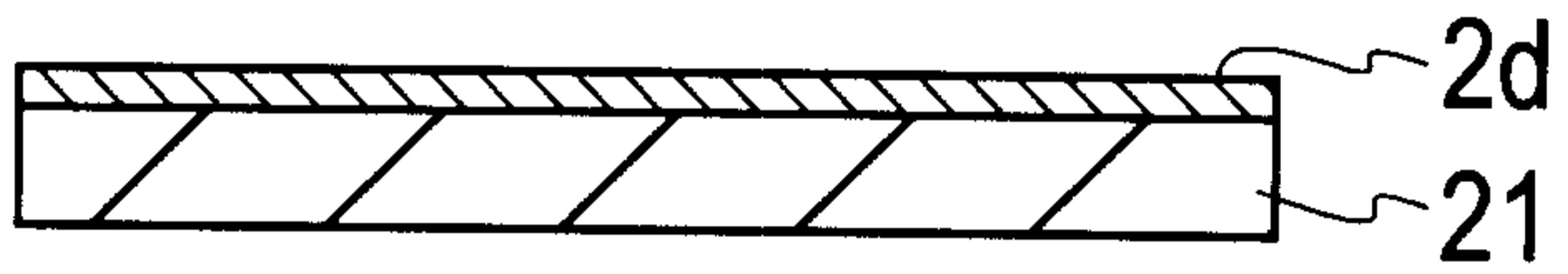

FIG.8B

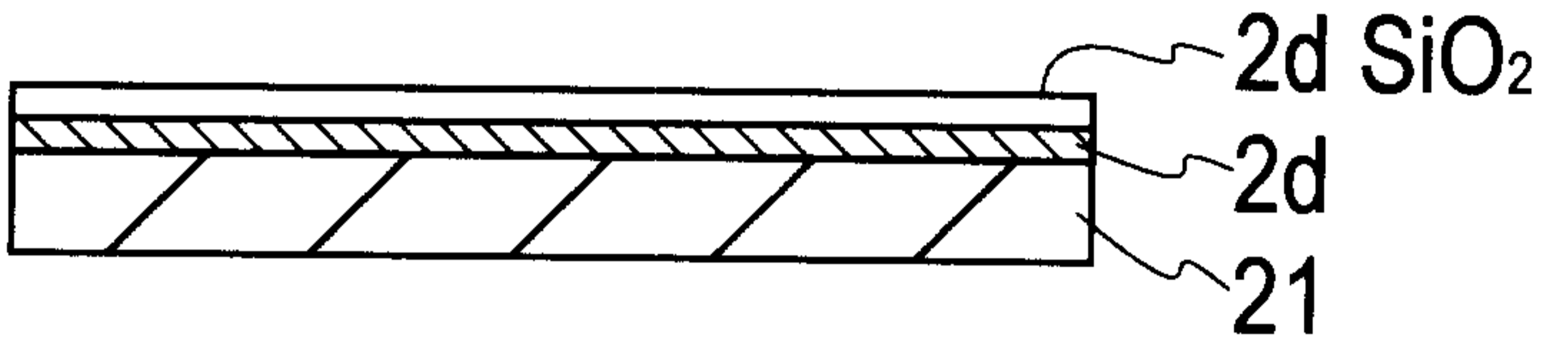

FIG.8C

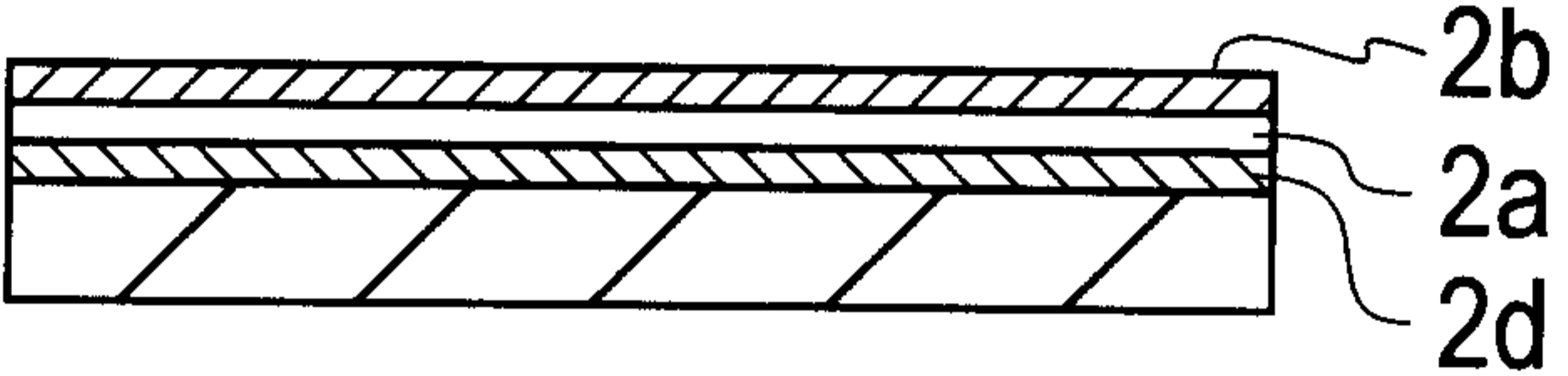

FIG.8D

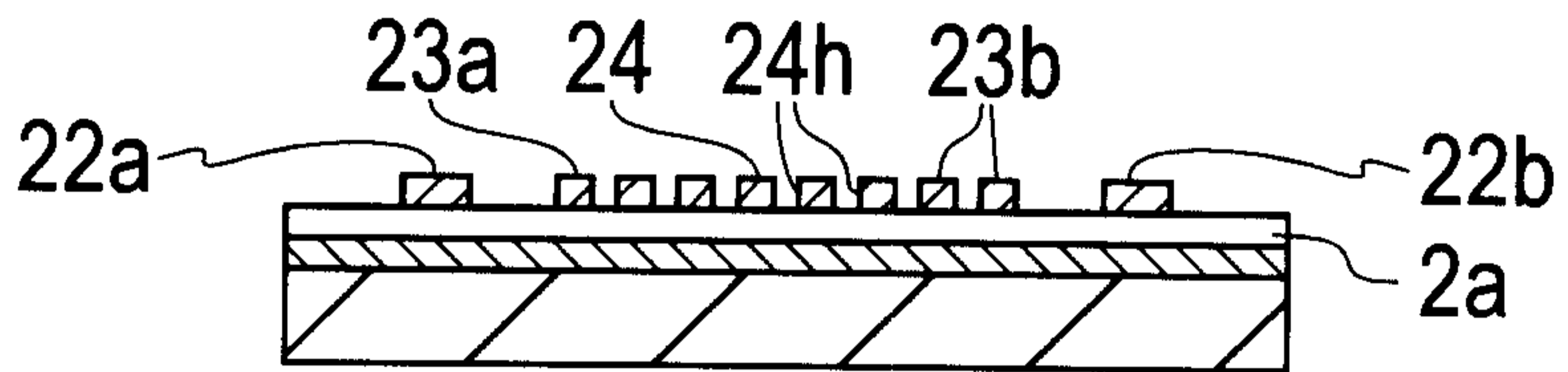

FIG.8E

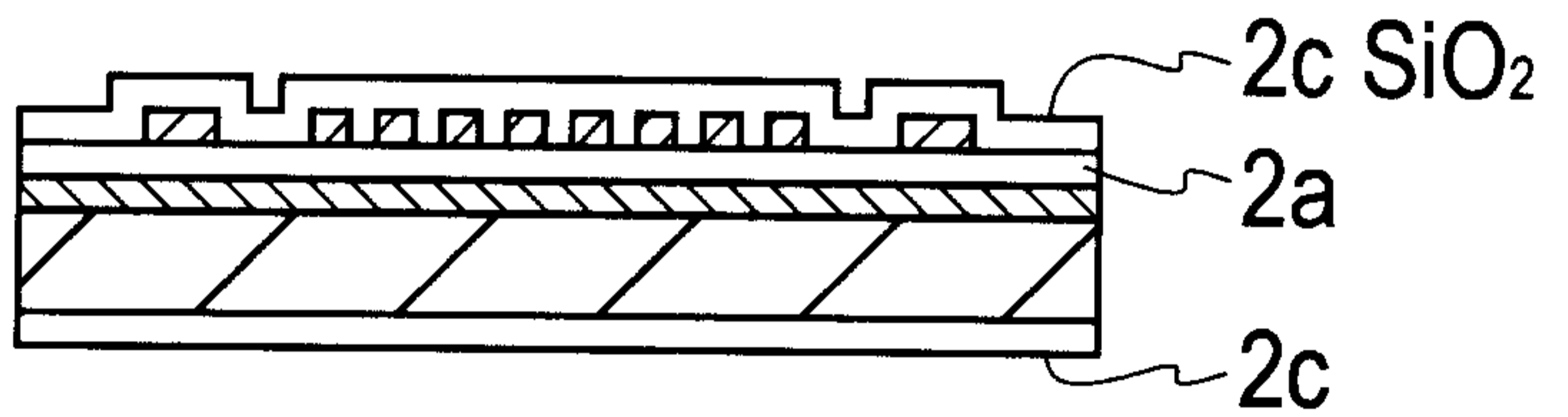

FIG.8F

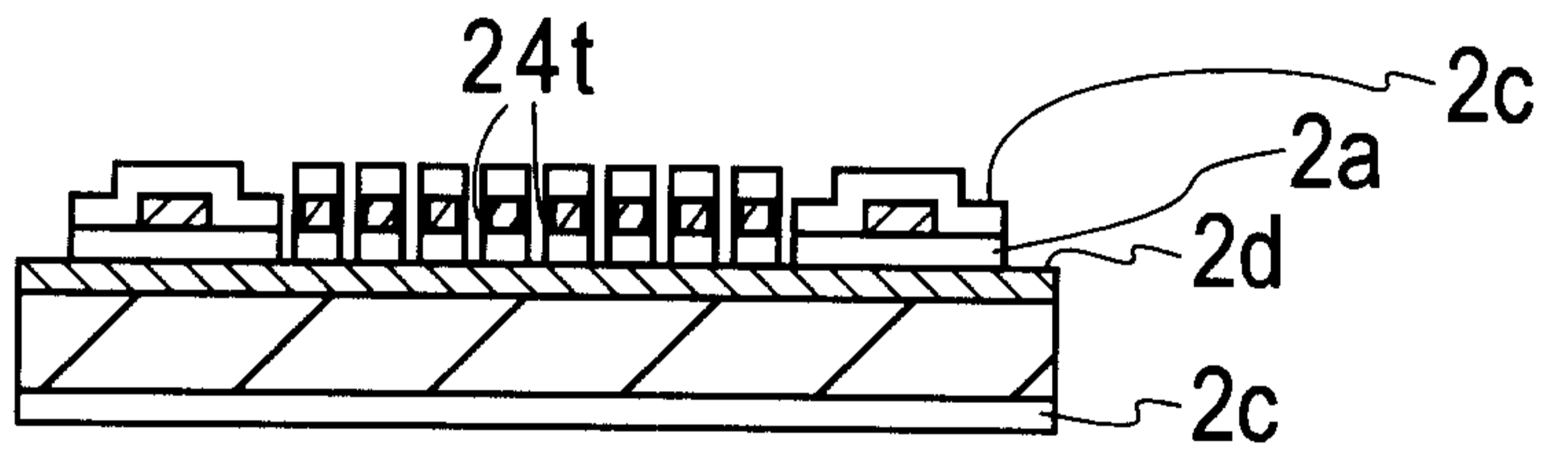

FIG.8G

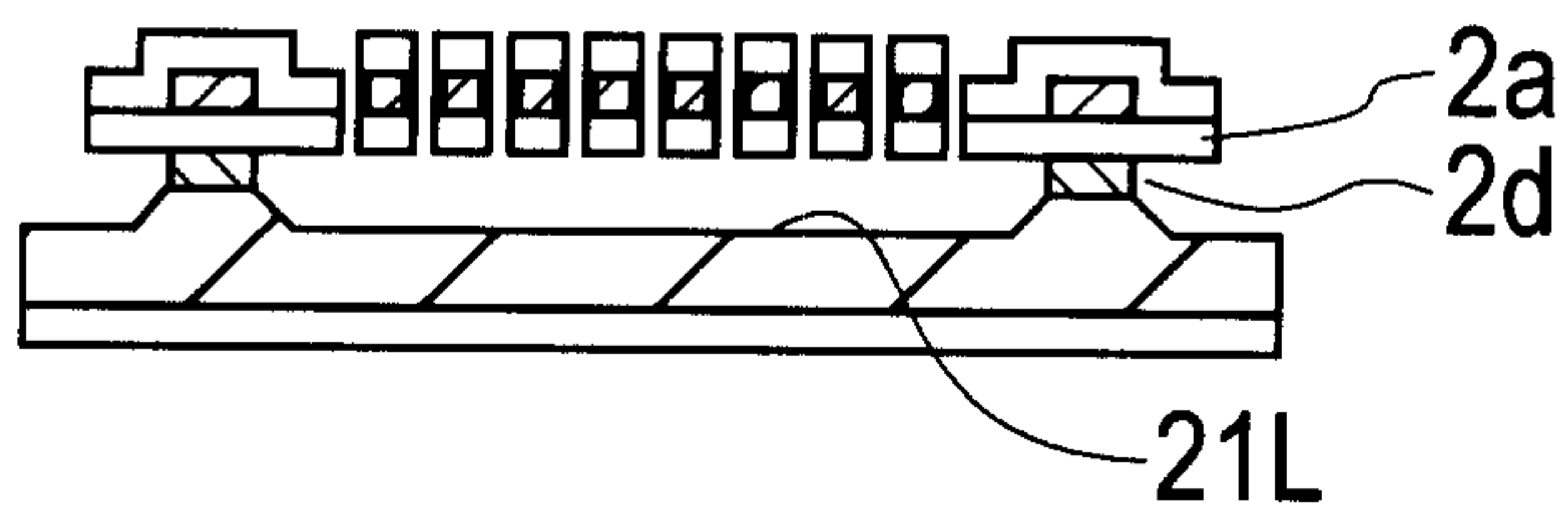

FIG.8H

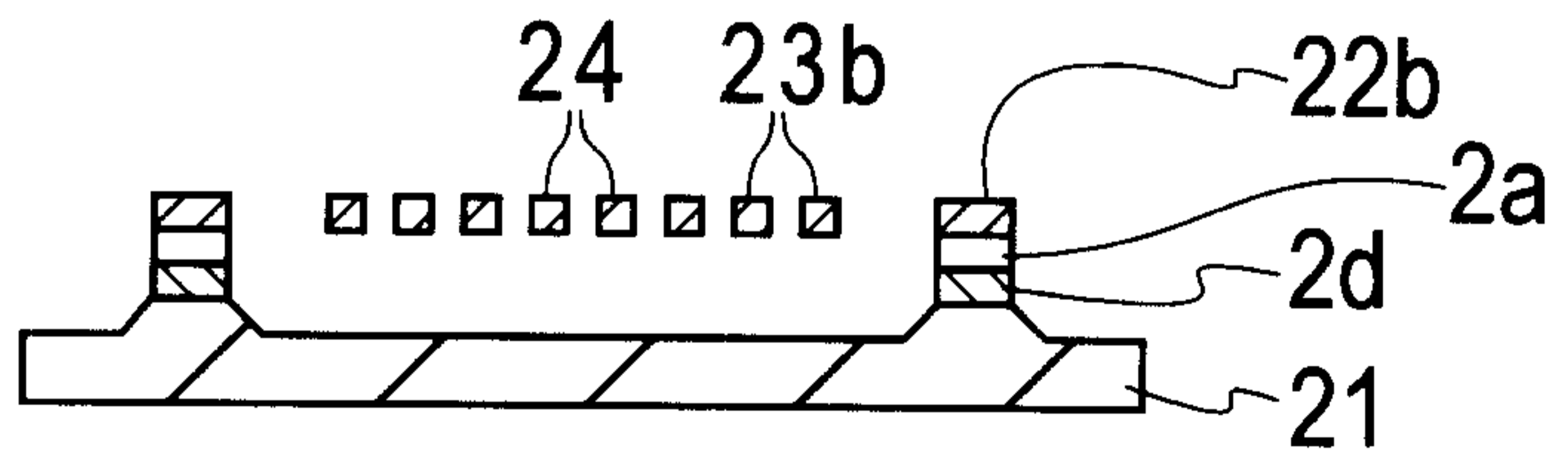

FIG.9A

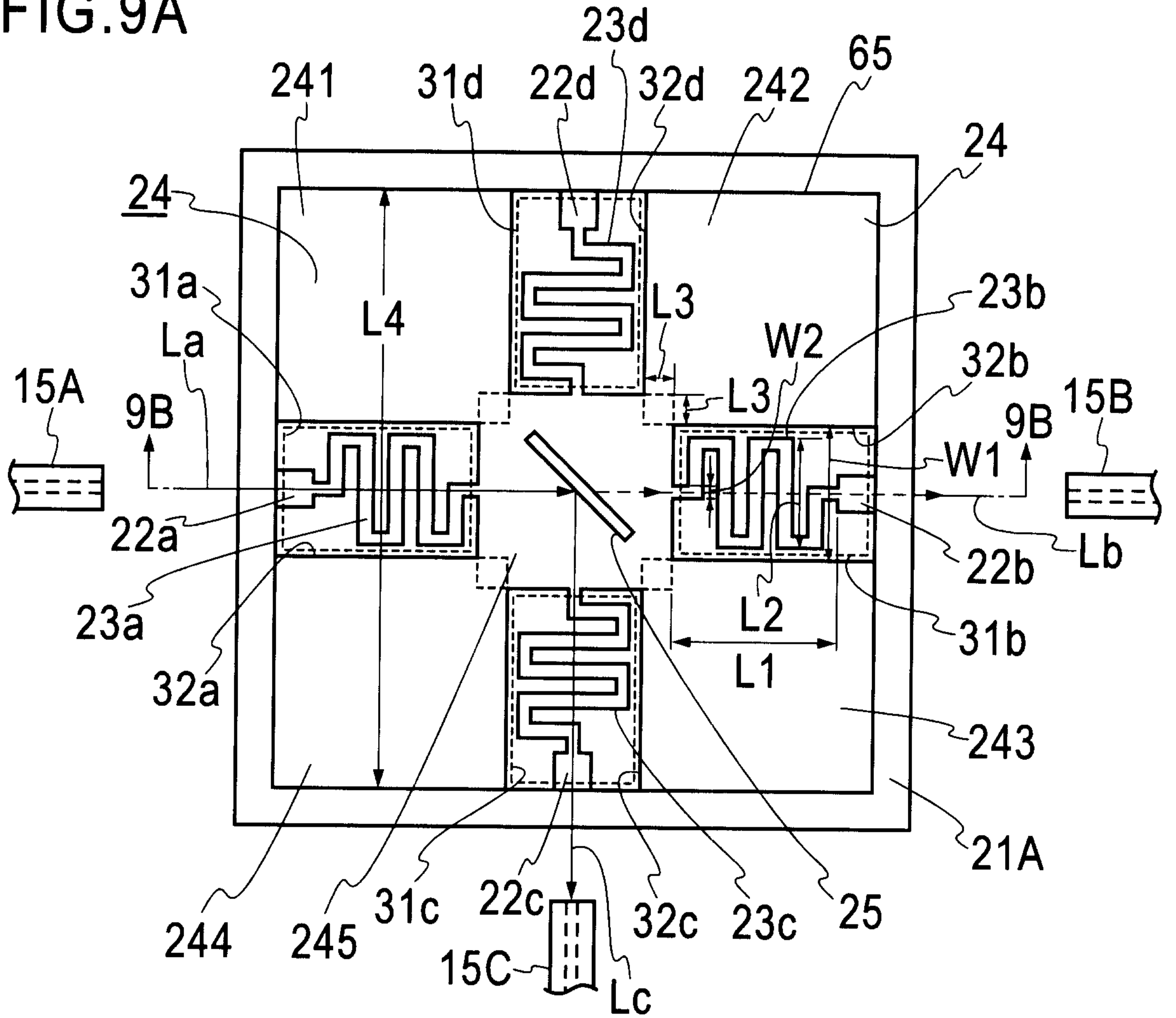

FIG.9B

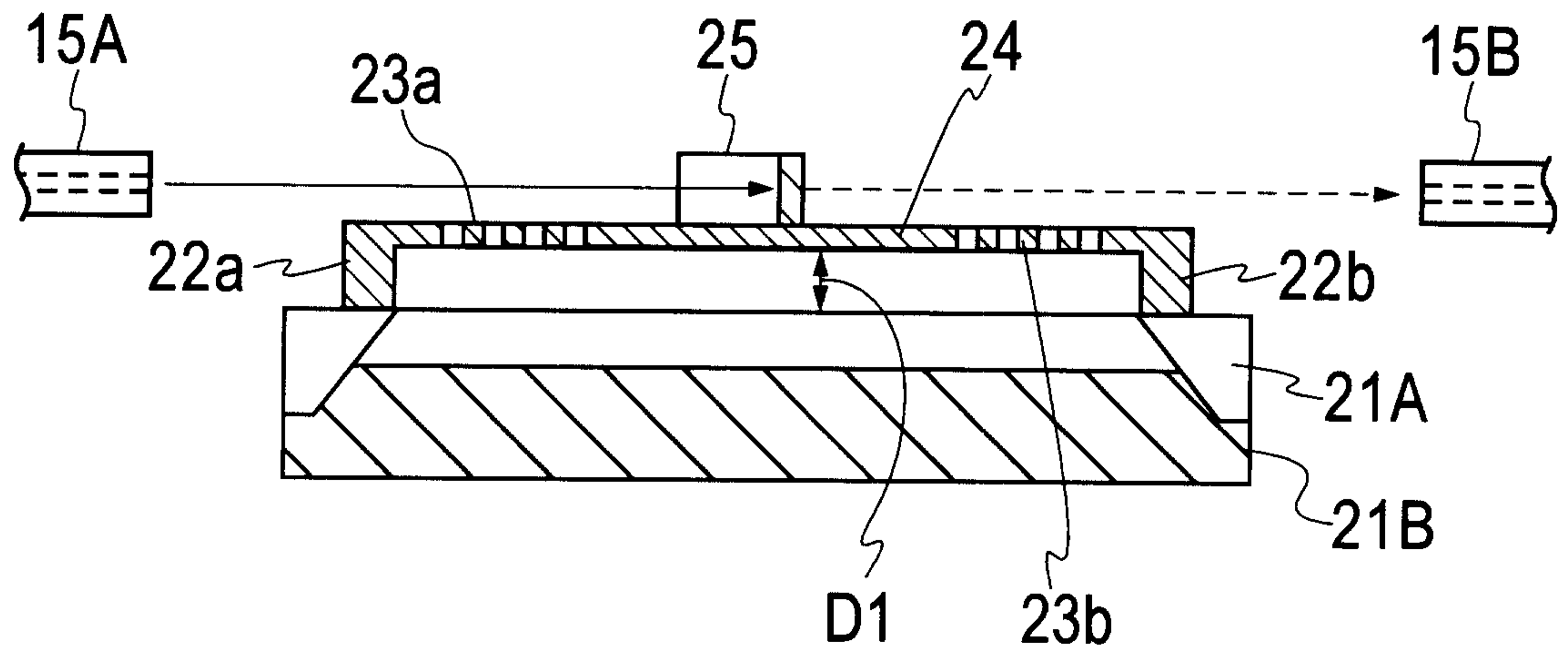

FIG.10

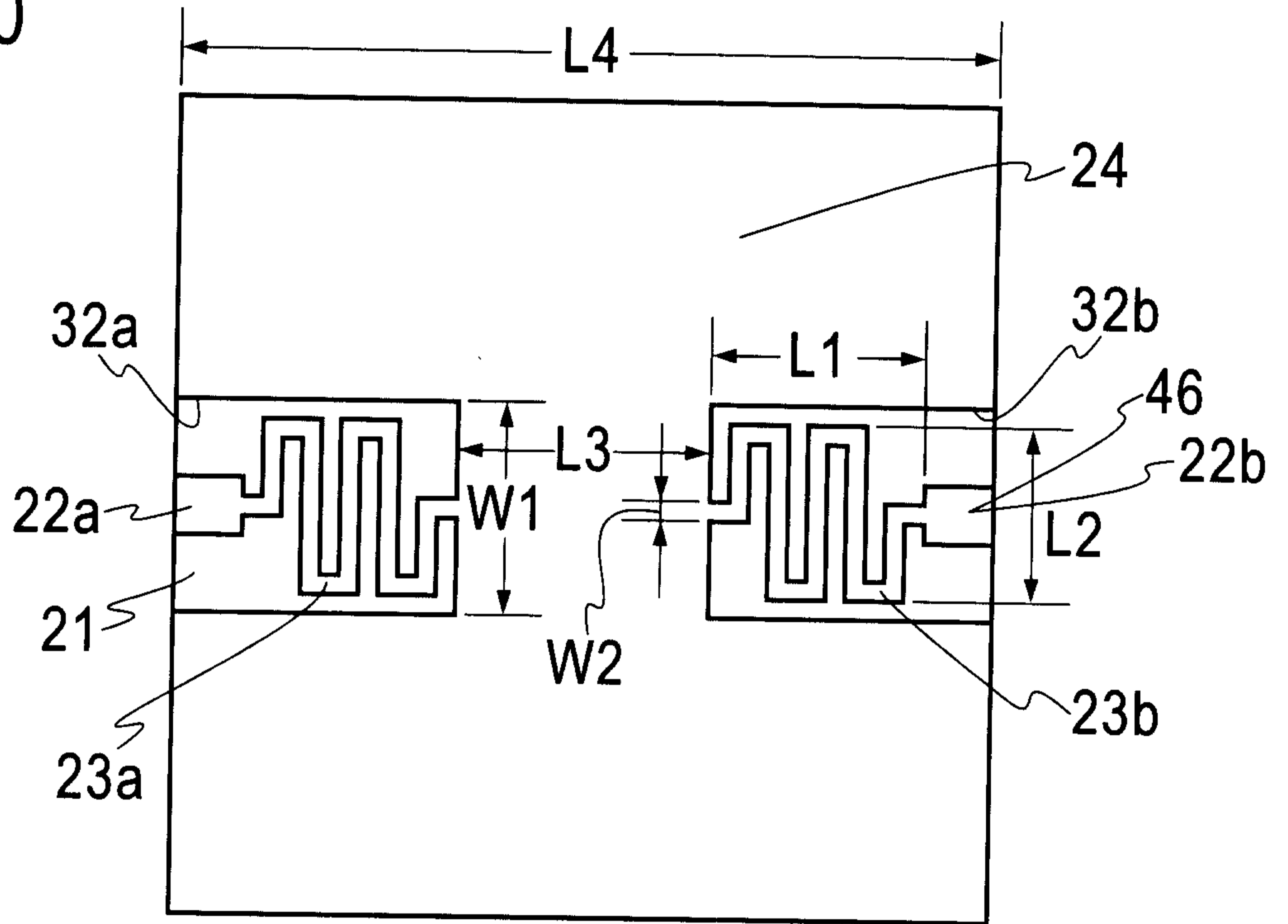

FIG.11

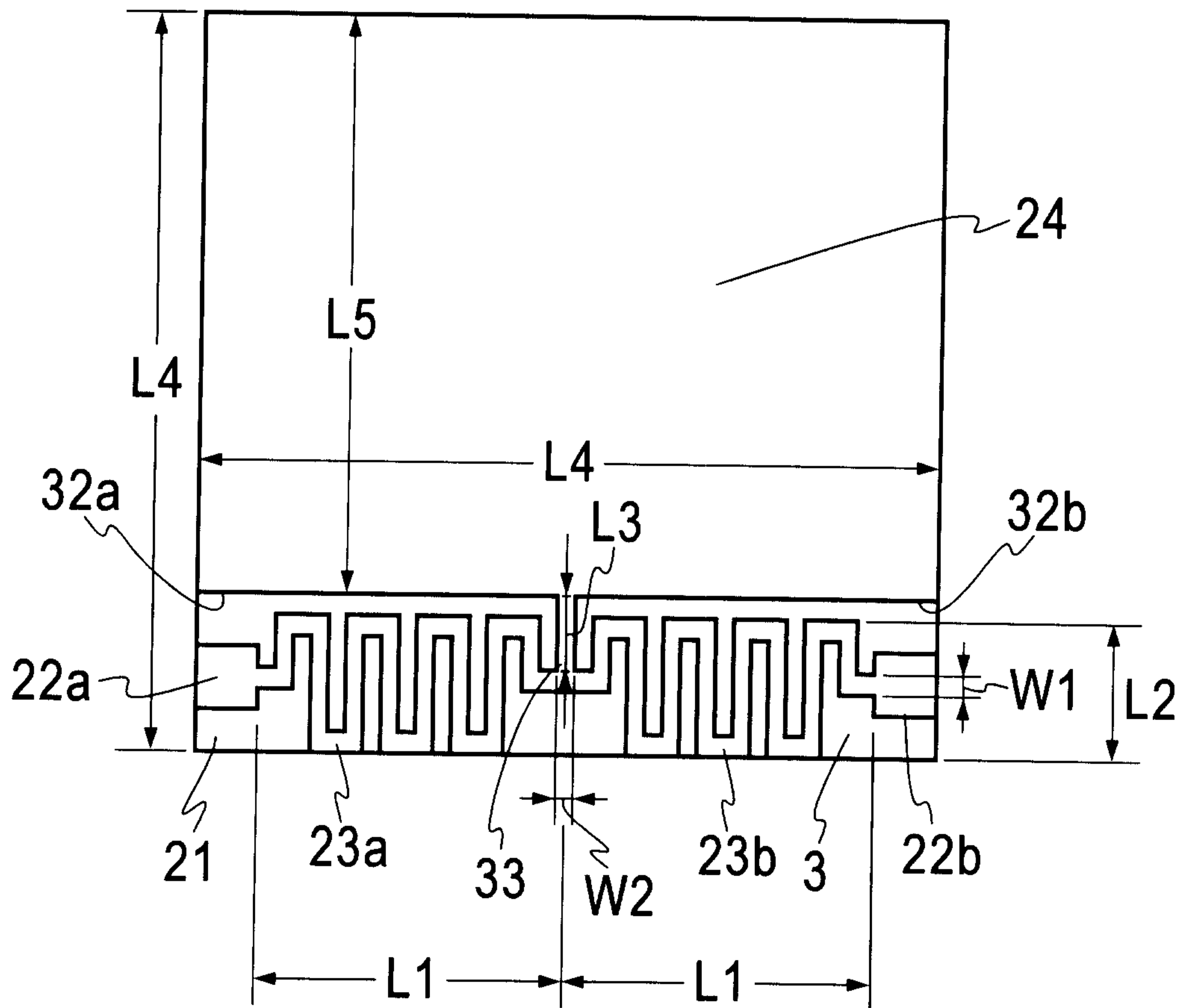

FIG. 12

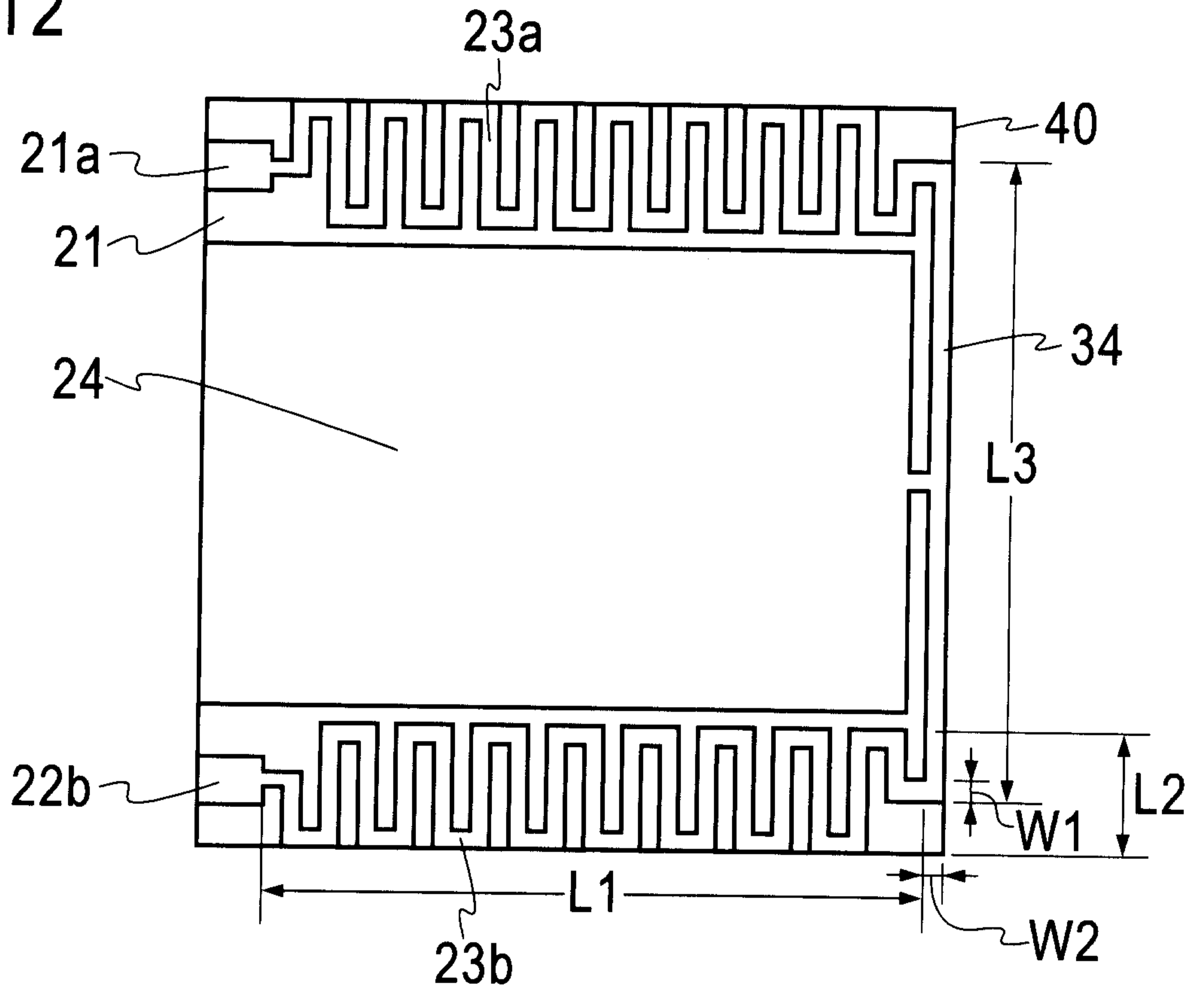

FIG. 13

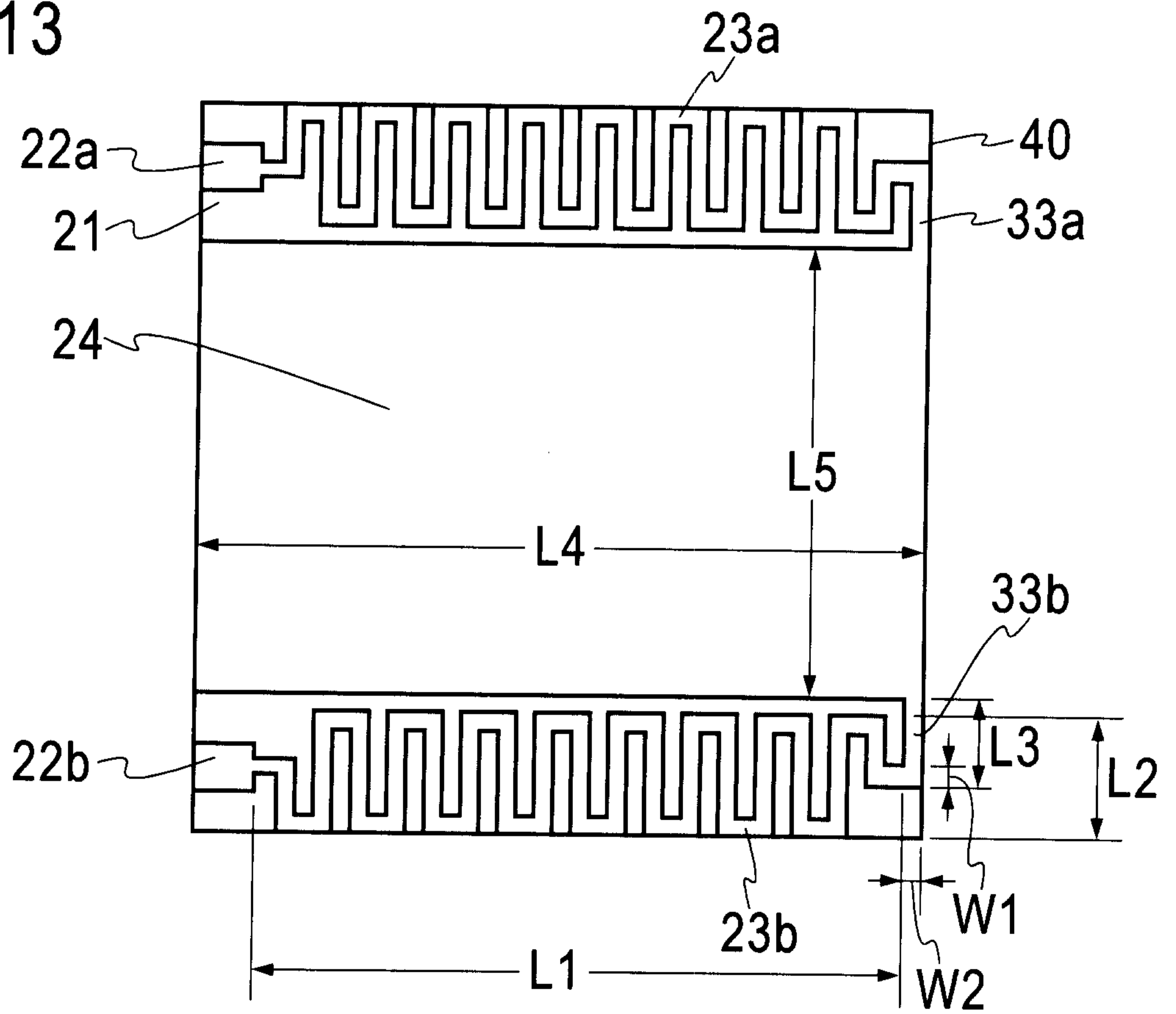

FIG. 14

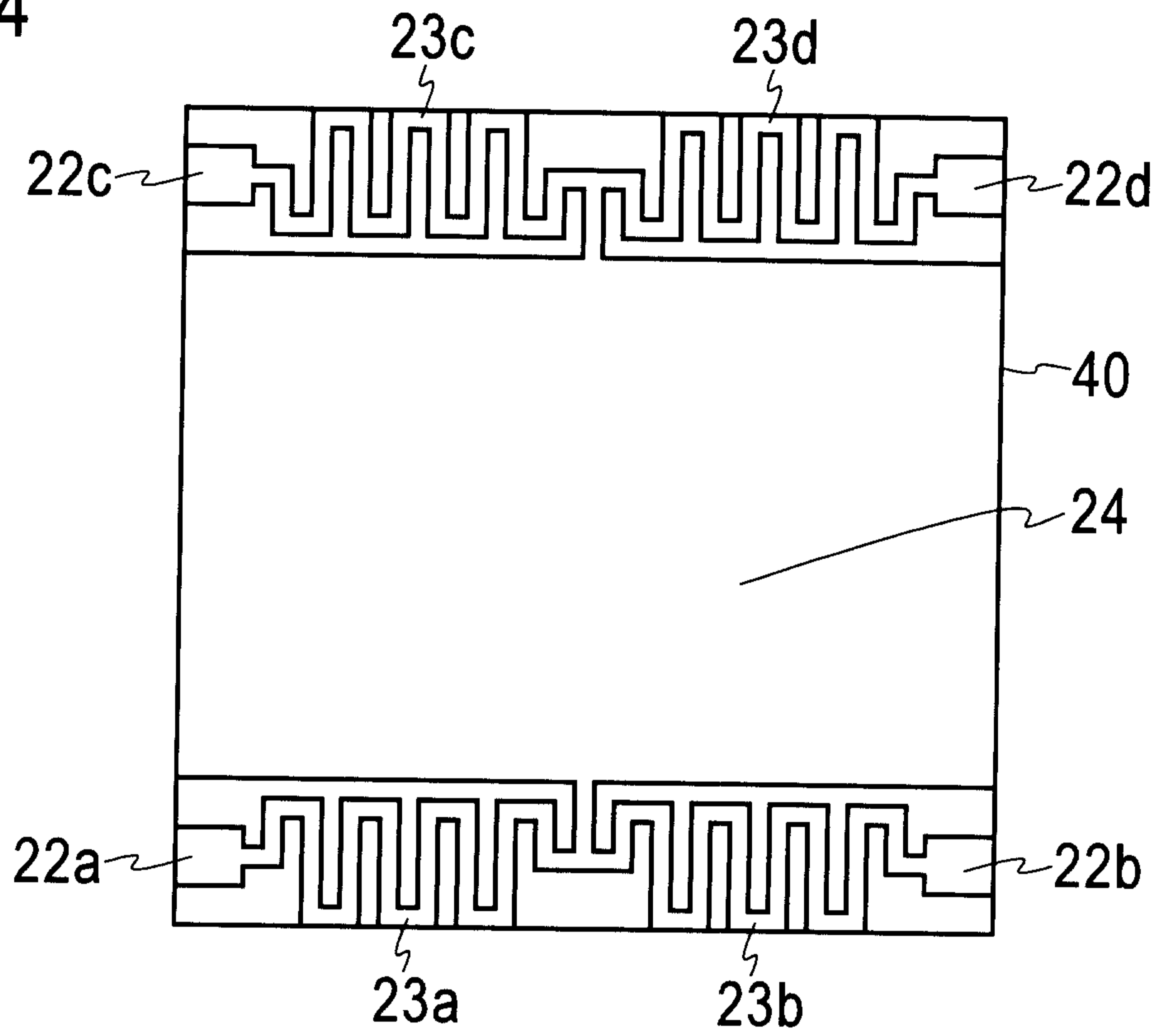

FIG. 15

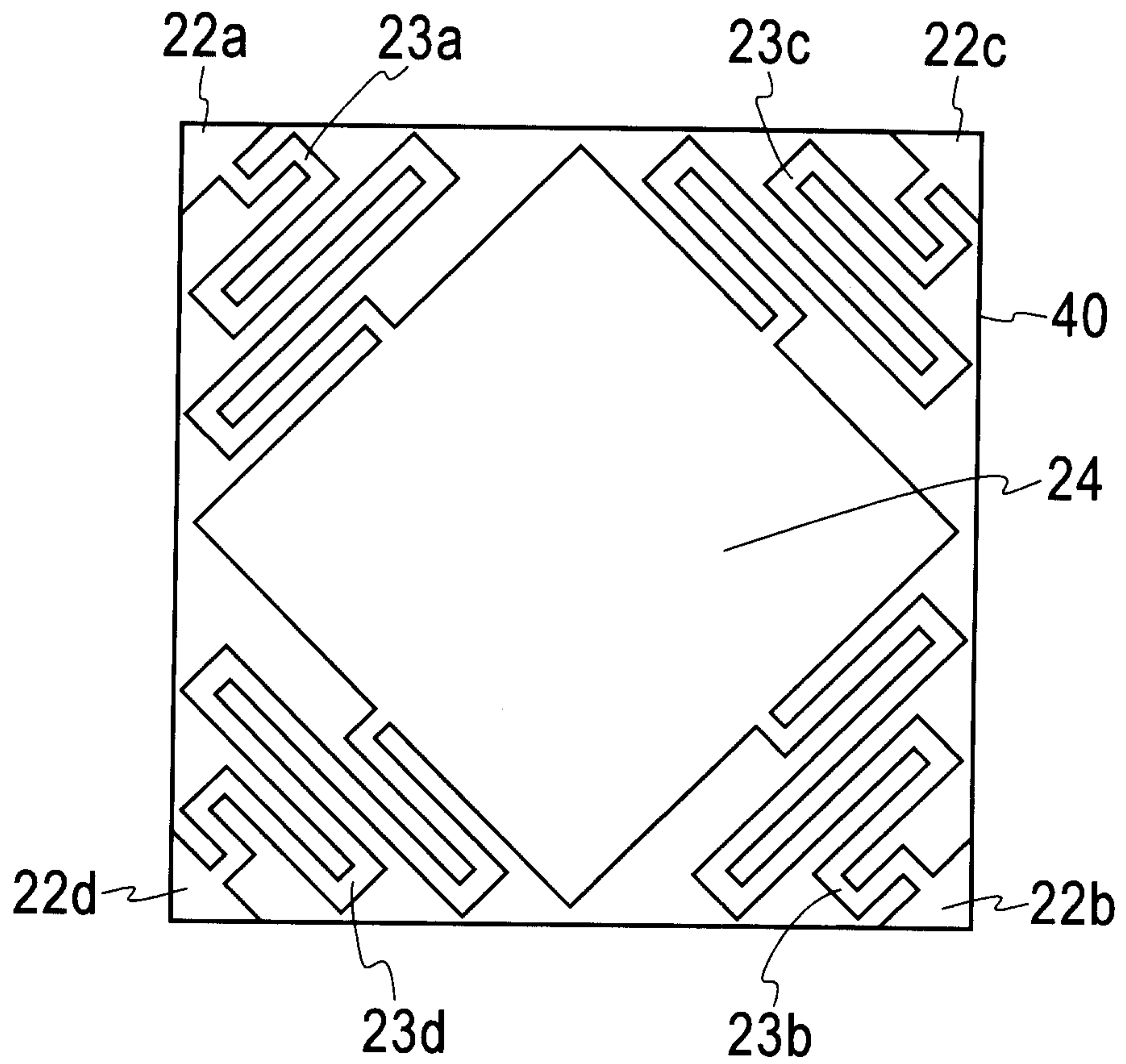

FIG. 16

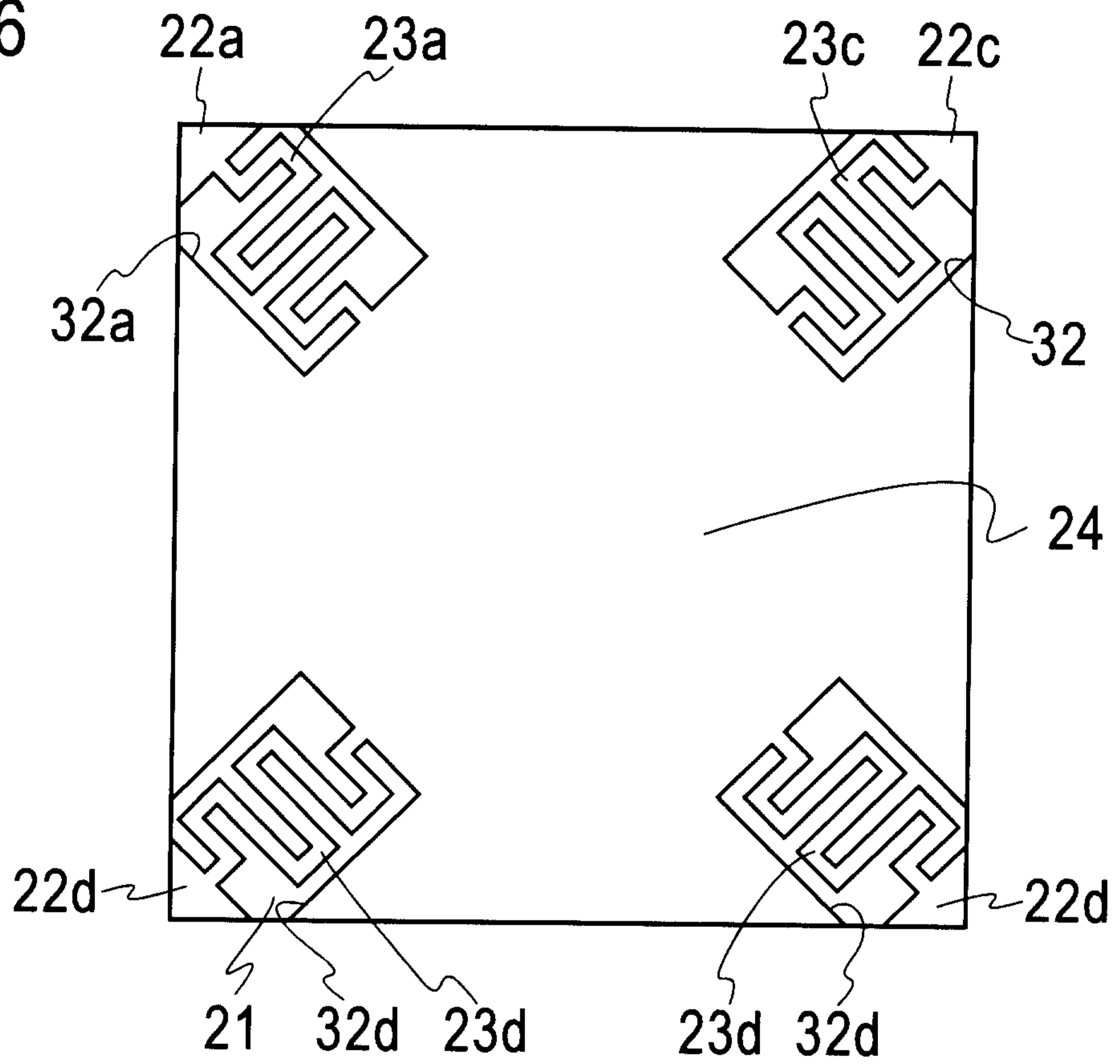

FIG. 17

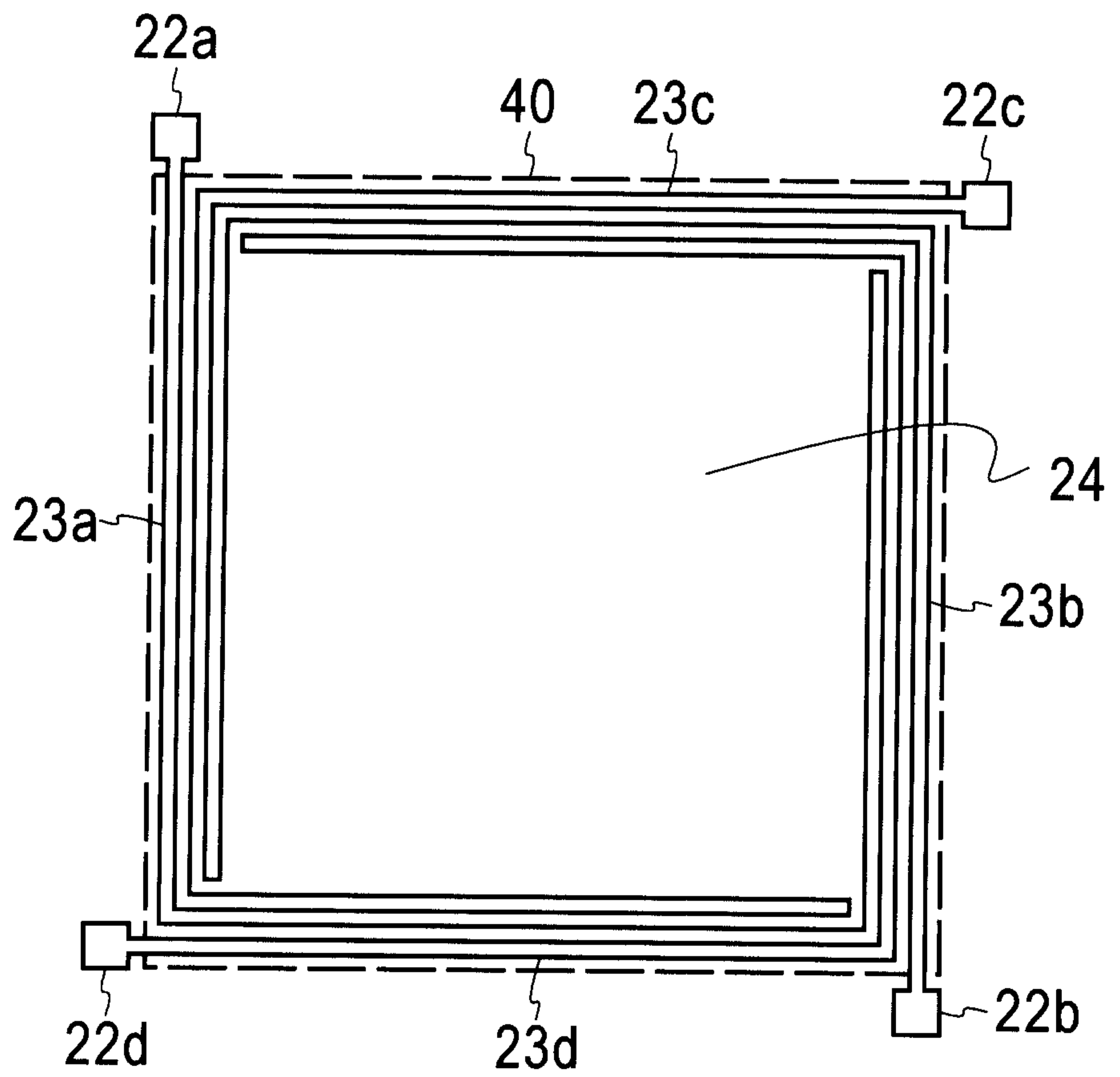

FIG. 18

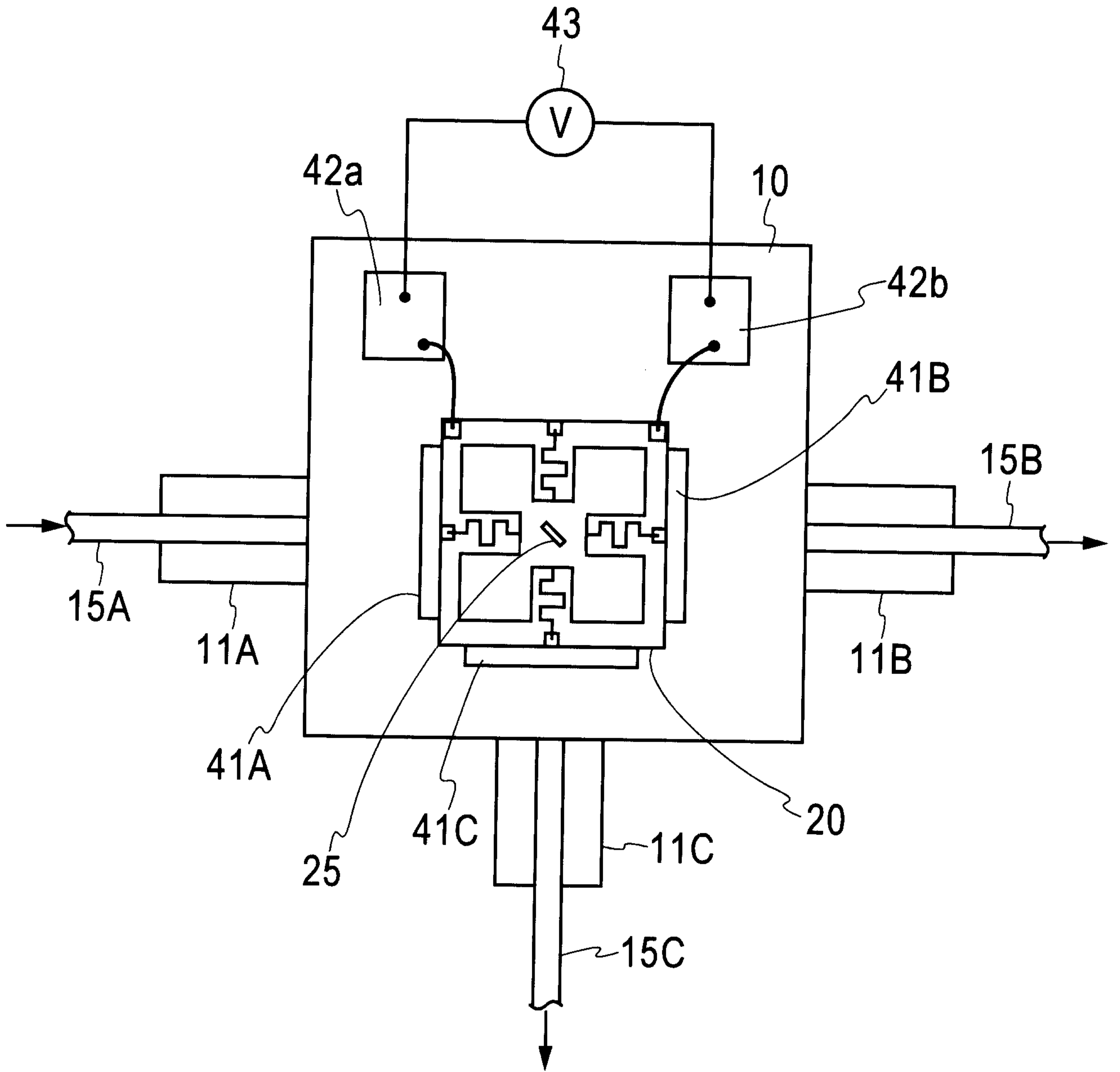

FIG.19

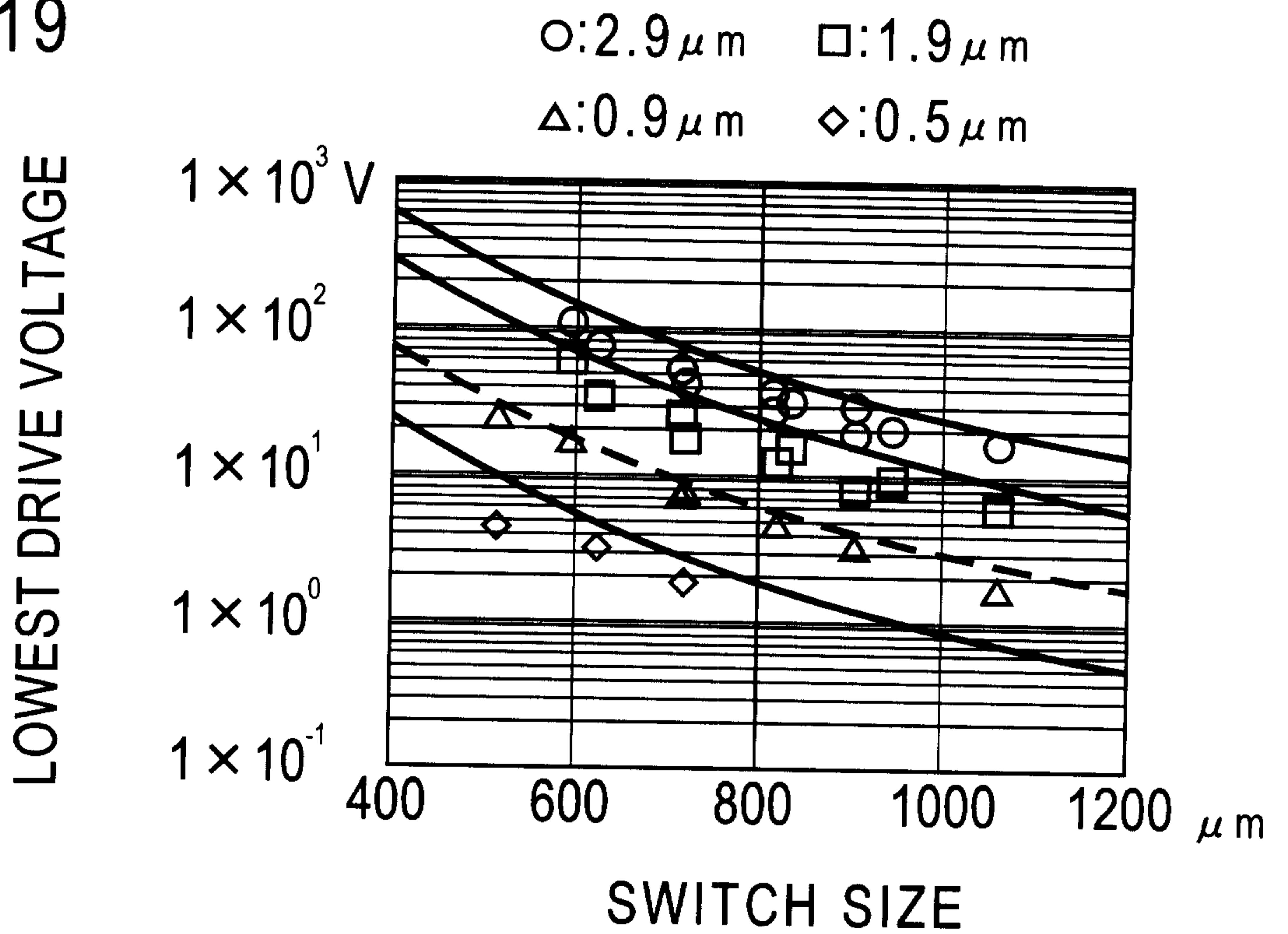

FIG.20

