

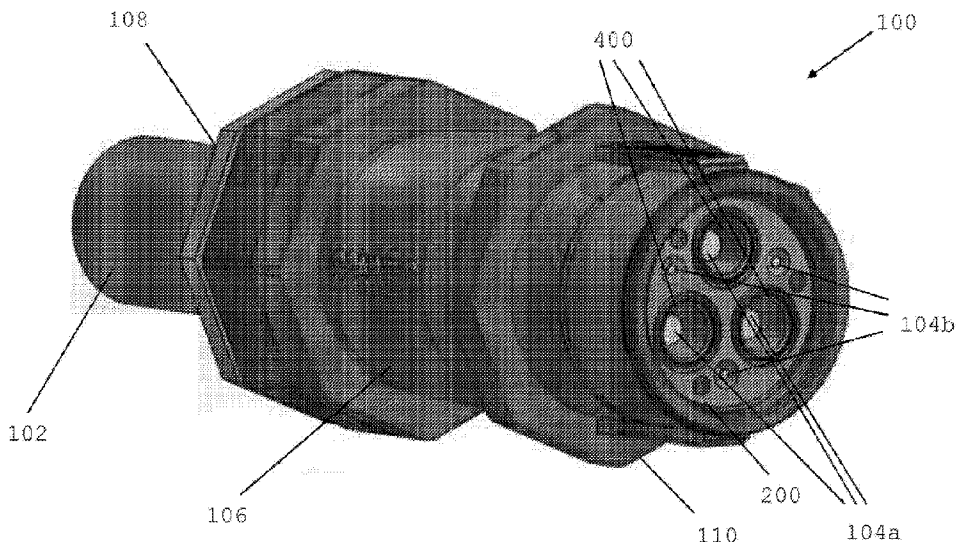

(86) Date de dépôt PCT/PCT Filing Date: 2014/11/27
 (87) Date publication PCT/PCT Publication Date: 2016/01/28
 (45) Date de délivrance/Issue Date: 2022/06/07
 (85) Entrée phase nationale/National Entry: 2017/01/10
 (86) N° demande PCT/PCT Application No.: AU 2014/001076
 (87) N° publication PCT/PCT Publication No.: 2016/011474
 (30) Priorité/Priority: 2014/07/24 (AU2014902875)

(51) Cl.Int./Int.Cl. *H01B 17/00* (2006.01),
H01B 7/00 (2006.01), *H01R 13/00* (2006.01),
H01R 29/00 (2006.01)
 (72) Inventeur/Inventor:
WILLIAMS, STEPHEN, AU
 (73) Propriétaire/Owner:
CONNEC LIMITED, AU
 (74) Agent: FASKEN MARTINEAU DUMOULIN LLP

(54) Titre : **CONNECTEUR ELECTRIQUE**
 (54) Title: **AN ELECTRICAL CONNECTOR**



(57) **Abrégé/Abstract:**

An electrical connection component for a machine cable is described. The electrical connection component is suitable for transmission of power with voltage levels greater than or equal to 1 kV and comprises at least one electrical conductor arranged for electrically coupling with a further electrical conductor of another electrical connection component. The electrical connection component comprises a housing having an internal region, and having a machine cable end, a connection end and a plurality of electrically insulating components positioned within the housing, at least one of the electrically insulating components being arranged so as to form-fit with a further one of the electrically insulating components. A portion of the internal region of the housing that is located at the connection end of the housing, and that would not otherwise be filled with the at least one electrical conductor and/or an associated flame path, is filled by the electrically insulating components.

(12) INTERNATIONAL APPLICATION PUBLISHED UNDER THE PATENT COOPERATION TREATY (PCT)

(19) World Intellectual Property
Organization
International Bureau(10) International Publication Number
WO 2016/011474 A1(43) International Publication Date
28 January 2016 (28.01.2016)

(51) International Patent Classification:

H01B 17/00 (2006.01) *H01B 7/00* (2006.01)
H01R 29/00 (2006.01) *H01R 13/00* (2006.01)

(21) International Application Number:

PCT/AU2014/001076

(22) International Filing Date:

27 November 2014 (27.11.2014)

(25) Filing Language:

English

(26) Publication Language:

English

(30) Priority Data:

2014902875 24 July 2014 (24.07.2014) AU

(71) Applicant: **CONNEX LIMITED** [AU/AU]; Suite 411,
19A Boundary Street, Rushcutters Bay, New South Wales
2010 (AU).(72) Inventor: **WILLIAMS, Steven**; c/- Connex Limited, Suite
411, 19a Boundary Street, Rushcutters Bay, New South
Wales 2010 (AU).(74) Agent: **GRIFFITH HACK**; Level 19, 109 St Georges
Terrace, Perth, Western Australia 6000 (AU).(81) Designated States (unless otherwise indicated, for every
kind of national protection available): AE, AG, AL, AM,
AO, AT, AU, AZ, BA, BB, BG, BH, BN, BR, BW, BY,
BZ, CA, CH, CL, CN, CO, CR, CU, CZ, DE, DK, DM,
DO, DZ, EC, EE, EG, ES, FI, GB, GD, GE, GH, GM, GT,
HN, HR, HU, ID, IL, IN, IR, IS, JP, KE, KG, KN, KP, KR,
KZ, LA, LC, LK, LR, LS, LU, LY, MA, MD, ME, MG,
MK, MN, MW, MX, MY, MZ, NA, NG, NI, NO, NZ, OM,
PA, PE, PG, PH, PL, PT, QA, RO, RS, RU, RW, SA, SC,
SD, SE, SG, SK, SL, SM, ST, SV, SY, TH, TJ, TM, TN,
TR, TT, TZ, UA, UG, US, UZ, VC, VN, ZA, ZM, ZW.(84) Designated States (unless otherwise indicated, for every
kind of regional protection available): ARIPO (BW, GH,
GM, KE, LR, LS, MW, MZ, NA, RW, SD, SL, ST, SZ,
TZ, UG, ZM, ZW), Eurasian (AM, AZ, BY, KG, KZ, RU,
TJ, TM), European (AL, AT, BE, BG, CH, CY, CZ, DE,
DK, EE, ES, FI, FR, GB, GR, HR, HU, IE, IS, IT, LT, LU,
LV, MC, MK, MT, NL, NO, PL, PT, RO, RS, SE, SI, SK,
SM, TR), OAPI (BF, BJ, CF, CG, CI, CM, GA, GN, GQ,
GW, KM, ML, MR, NE, SN, TD, TG).

Published:

— with international search report (Art. 21(3))

(54) Title: AN ELECTRICAL CONNECTOR

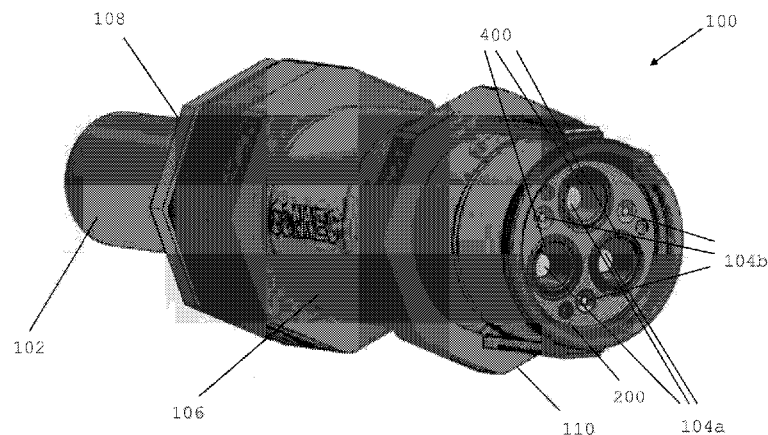

FIGURE 1

(57) Abstract: An electrical connection component for a machine cable is described. The electrical connection component is suitable for transmission of power with voltage levels greater than or equal to 1 kV and comprises at least one electrical conductor arranged for electrically coupling with a further electrical conductor of another electrical connection component. The electrical connection component comprises a housing having an internal region, and having a machine cable end, a connection end and a plurality of electrically insulating components positioned within the housing, at least one of the electrically insulating components being arranged so as to form-fit with a further one of the electrically insulating components. A portion of the internal region of the housing that is located at the connection end of the housing, and that would not otherwise be filled with the at least one electrical conductor and/or an associated flame path, is filled by the electrically insulating components.



WO 2016/011474 A1

AN ELECTRICAL CONNECTORFIELD OF THE INVENTION

The present invention relates to an electrical connector
5 used in high power applications. In particular the present
invention relates to a connector suitable for use in
demanding environments such as the petroleum or mining
industry.

10 BACKGROUND OF THE INVENTION

Reliable electrical connections are crucial in high power
applications, such as powering of heavy electrical
machinery often used in the mining or petroleum industry,
or connection of power transportation lines. In these
15 applications the electrical cables transmit high currents
at voltages of one or more kV.

Typical electrical connectors used in the art have a
plurality of pins or sockets, each being connected to a
20 respective core of an electrical cable. Depending on the
specific application, the connectors must comply with
specific requirements or standards. The compliance of the
connectors with the relevant standards is examined by a
certifying body.

25

The certification of a connector for a specific
application generally ensures that the connector meets
basic safety requirements. While known certified
connectors are now relatively safe to operate, they still
30 have a number of disadvantages. For example, although high
power connectors used in the tunnelling, mining or
petroleum industries typically need to comply with strict
requirements including requirements related to explosions,

- 2 -

it may be advantageous to provide a high power connector that further reduces a risk, or the effect of, an explosion or similar.

5 SUMMARY OF THE INVENTION

In accordance with a first aspect of the present invention, there is provided an electrical connection component for a machine cable, the electrical connection component being suitable for transmission of power with
10 voltage levels greater than or equal to 1 kV, the electrical connection component comprising:

at least one electrical conductor being arranged for electrically coupling with a further electrical conductor of another electrical connection component;

15 a housing having an internal region, and having a machine cable end and a connection end; and

a plurality of electrically insulating components positioned within the housing, at least one of the electrically insulating components being arranged so as to
20 form-fit with a further one of the electrically insulating components;

wherein a portion of the internal region of the housing that is located at the connection end of the housing, and that would not otherwise be filled with the
25 at least one electrical conductor and/or an associated flame path, is filled by the electrically insulating components.

The electrically insulating components may fill 10% or
30 less, 20% or less, 30% or less, 40% or less, 50% or less, 60% or less, 70% or less, 80% or less, 90% or less, or 100% or less of the internal region of the housing measuring from the connection end that would not otherwise

- 3 -

be filled with the at least one electrical conductor and/or an associated flame path.

In a specific embodiment, the insulating components fill
5 more than 70%, 80% or 90% of the internal volume of an internal portion of the housing. The internal portion may fill more than 90%, 80% 70%, 60%, 50% 40%, 30% or 20% of the internal volume of the housing.

10 It will be appreciated that the at least one electrical conductor will typically comprise an electrical conductor portion that is electrically couplable to a core of the machine cable, and an electrical contact portion that is electrically couplable to a respective electrical contact
15 portion of the electrical conductor of the electrical connector.

The flame path referred to above may be arranged adjacent to the electrical conductor. The flame path facilitates
20 minimising the risk of explosion inside the electrical connection component. The flame path is sufficiently narrow to control the amount of energy that can be generated by an explosion spreading to other areas of the connector.

25

Filling a portion of the internal region of the housing with the electrically insulating components may be advantageous in reducing an amount of air within the housing. Reducing the amount of air within the housing may
30 reduce a risk, or the effect, of an explosion.

The plurality of electrically insulating components may be arranged such that the at least one conductor penetrates

- 4 -

through each of the electrically insulating components.

The plurality of electrically insulating components may be arranged such that they fit within the housing in a predefined orientation or set of orientations. For
5 example, a first electrically insulating component may be shaped so as to fit with a second electrically insulating component in a predefined orientation. For example, the first electrically insulating component may have a
10 protrusion having a particular shape, with the second insulating component having a correspondingly shaped recess for receiving the protrusion of the first electrically shaped recess wherein, when the first insulating component is received in the second insulating
15 component, the first and second insulating components have a predefined orientation with respect to one another.

Further, an electrically insulating component may be arranged so as to receive a plurality of other
20 electrically insulating components, wherein at least one of the electrically insulating components surrounds at least a portion of the at least one conductor, the at least one conductor penetrating therethrough.

25 The electrically insulating components may comprise a high density polymeric material, preferably being void free. It will be appreciated that one or more of the electrically insulating components may comprise a different polymeric material than one or more other of the electrically
30 insulating components.

At least one of the electrically insulating components may be arranged to form-fit with at least a portion of the

- 5 -

housing.

Each electrically insulating component may be arranged so as to form-fit with a further electrically insulating
5 component.

At least one of the electrically insulating components may comprise a passage for receiving a further electrically insulating component therewithin. At least a portion of
10 the passage may be shaped such that the further electrically insulating component fits within the passage in a predefined orientation. Such an arrangement may be advantageous in that the further electrically insulating component, which may house the at least one electrical
15 conductor, is not twisted or otherwise moved in an undesired manner, which may facilitate preventing damage being caused to the electrical conductor.

In one embodiment, the electrical connection component
20 comprises a first electrically insulating component that form-fits with a second electrically insulating component, the first electrically insulating component being arranged at the connection end of the housing, the second electrically insulating component being arranged between
25 the first electrically insulating component and the machine cable end of the housing. The first and second electrically insulating components may be arranged to receive at least one third electrically insulating component through at least a portion of each of the first
30 and second electrically insulating components. In one embodiment, the first and second electrically insulating components comprise respective passages that are aligned so as to receive the third electrically insulating

- 6 -

component therethrough. The respective passages of the first and second electrically insulating components, and the at least one third electrically insulating component, may be arranged such that the at least one third
5 electrically insulating component form-fits with the first and second electrically insulating components.

The at least one third electrically insulating component may comprise a flange having a particular shape, the first
10 or the second electrically insulating component comprising a recess having a shape corresponding to that of the flange of the third electrically insulating component such that the third electrically insulating component can only be arranged through the first and second electrically
15 insulating components in one orientation.

In one embodiment, the at least one third electrically insulating component comprises a tube that is arranged for receiving the at least one electrical conductor, the tube
20 comprising a first material comprising an insulating material, the first material surrounding a length of the at least one electrical conductor that has been received by the tube, and a second material comprising a conductive material arranged to be electrically couplable to an earth
25 of the machine cable, the second material surrounding the first material substantially along a length of the third electrically insulating component.

The first and second electrically insulating components
30 may be substantially cylindrically shaped.

In accordance with a second aspect of the present invention, there is provided a method of forming an

- 7 -

electrical connection component, the electrical connection component being in accordance with the first aspect of the present invention, the method comprising the steps of:

5 providing the housing, the at least one electrical conductor, and the plurality of electrically insulating components; and

10 form-fitting at least one of the electrically insulating components with a further one of the electrically insulating components within the housing such that a portion of the internal region of the housing that is located at the connection end of the housing, and that would not otherwise be filled with the at least one electrical conductor and/or an associated flame path, is filled by the electrically insulating components.

15

The invention will be more fully understood from the following description of specific embodiments of the invention. The description is provided with reference to the accompanying drawings.

20

BRIEF DESCRIPTION OF THE DRAWINGS

Figure 1 is a front perspective view of an electrical connection component in accordance with an embodiment of the present invention;

25

Figure 2a is a front perspective view of a first electrically insulating component of the electrical connection component of Figure 1;

30

Figure 2b is a top plan view of the first electrically insulating component of Figure 2a;

Figure 3a is a front perspective view of a second

- 8 -

electrically insulating component of the electrical connection component of Figure 1;

Figure 3b is a reverse perspective view of the second electrically insulating component of Figure 3a;

Figure 3c is a cross sectional side view of the second electrically insulating component of Figure 3a;

Figure 3d is a bottom plan view of the second electrically insulating component of Figure 3a;

Figure 4a is a rear perspective view of a third electrically insulating component of the electrical connection component of Figure 1;

Figure 4b is a cutaway side view of the third electrically insulating component of Figure 4a;

Figure 5 is a rear perspective view of an alternative second electrically insulating component of the electrical connection component of Figure 1;

Figure 6 is a cross sectional view of the electrical connection component of Figure 1; and

Figure 7 is a flowchart of a method of forming the electrical connection component of Figure 1.

30 DETAILED DESCRIPTION OF SPECIFIC EMBODIMENTS

Referring initially to Figure 1, there is shown an electrical connection component 100 for a machine cable 102. In this example, the electrical connection component

- 9 -

100 is suitable for the delivery of power of more than 50 kW. The electrical connection component 100 comprises a plurality of electrical conductors 104a, 104b the conductors being arranged for electrically coupling with
5 respective electrical contacts of a further electrical connector (not shown), and a housing 106 having an internal region, a machine cable end 108 and a connection end 110.

10 The electrical connection component 100 further comprises a plurality of electrically insulating components positioned within the housing 106. In this example, the electrical connection component 100 comprises a first electrically insulating component 200, also referred to
15 herein as a plug cap 200 (see Figure 2), a second electrically insulating component 300, also referred to herein as a plug body 300 (see Figure 3), and three third electrically insulating components 400, also referred to herein as phase earth tube insulators 400 (see Figure 4).

20 The electrically insulating components 200, 300, 400 are arranged to form-fit with one another, and with the housing 106, such that a portion of the internal region of the housing 106 that is located at the connection end 110
25 of the housing 106, and that would not otherwise be filled by the electrical conductors 104 and/or their associated flame paths, is filled by the electrically insulating components 200, 300, 400.

30 The portion of the internal region of the housing 106 that is located at the connection end 110 and that is filled with the electrically insulating components may account for 10% or less, 20% or less, 30% or less, 40% or less,

- 10 -

50% or less, 60% or less, 70% or less, 80% or less, 90% or less, or 100% or less of the length of the housing measuring from the connection end.

5 Filling a portion of the internal region of the housing 106 with the electrically insulating components 200, 300, 400 may be advantageous in reducing an amount of air within the housing. Reducing the amount of air within the housing may reduce a risk, or the effect, of an explosion.

10

The electrically insulating components typically comprise a high density polymeric material, preferably being void free. It will be appreciated that one or more of the electrically insulating components may comprise a
15 different polymeric material than one or more other of the electrically insulating components.

Referring to Figure 2, the plug cap 200 is arranged at the connection end 110 of the housing 106. The plug cap 200
20 comprises a plurality of first passages 202 for receiving the phase earth tube insulators 400 therethrough, and a plurality of second passages 204 for receiving respective form-fitting portions 302 of the plug body 300.

25 Referring to Figure 3, the plug body 300 comprises a plurality of first passages 304 that, when the plug body 300 is form-fitted with the plug cap 200, are aligned with the first passages 202 of the plug cap 200.

30 The form-fitting portions 302 of the plug body 300 facilitate form-fitting the plug body 300 with the plug cap 200. The plug body 300 also comprises a plurality of second passages 306 running through the plug body 300 and

- 11 -

through a central axis of each respective form-fitting portion 302. The second passages 306 are arranged so as to align with the second passages 204 of the plug cap 200 such that the conductors 104b, which in this example are electrically couplable to a pilot/auxiliary circuit, can run therethrough.

An example phase earth tube insulator 400 is shown in more detail in Figure 4. Each phase earth tube insulator 400 comprises an inner tube 402 that is arranged for receiving a respective electrical conductor 104a. In this example, each electrical conductor 104a is arranged for carrying a respective phase of a three phase power distribution network. The inner tube 402 comprises an insulating material such as one or more of the aforementioned polymer materials. The inner tube is surrounded by an outer tube 404, the outer tube 404 comprising a material such as copper that can function as an electrical earth when electrically coupled to an earth of the machine cable 102.

Each phase earth tube insulator 400 may have a flame path (not shown) to minimise the risk of explosion inside the phase earth tube insulator. The flame path is defined by an inner surface of the phase earth tube insulator which is disposed in proximity to a respective electrical pin. The space gap between the electrical pin and the inner surface of the phase earth tube insulator is sufficiently narrow to prevent excessive heating of a gas inside the phase tube and minimise the risk of an explosion.

In this example, the phase earth tube insulator 400 is received by the first passages 202, 304 of the plug cap 200 and the plug body 300. The phase earth tube insulator

- 12 -

400 and the first passages 202, 304 are shaped such that the phase earth tube insulator 400 form-fits with the plug cap 200 and the plug body 300.

5 In this example, the phase earth tube insulator 400 comprises a flanged rear portion 406 having a specific shape. The flanged rear portion 406 can be shaped so as to correspond to a shape of an opening 308 of each of the first passages 304 of the plug body 300 such that the
10 phase earth tube insulator 400 is retained in a particular orientation when form-fitted with the plug body 300 and the plug cap 200.

The shape of the flanged rear portion 406 in this example
15 corresponds to the shape of respective apertures 502 of the first passages 504 of the plug body 500 shown in Figure 5. It will be appreciated that the respective shapes of the flanged rear portion 406 of the phase earth tube insulator 400 and the apertures 502 of the plug body
20 500 may be any appropriate corresponding shapes.

Typically, the shape of the flanged rear portion 406 of the phase earth tube insulator 400 and the shape of the aperture 502 of the plug body 500 is such that the phase earth tube insulator 400 can be arranged in only one
25 orientation, thereby preventing any twisting of the earth tube insulator that might otherwise cause damage to a conductor contained therein.

Figure 6 shows a cross sectional view of the electrical
30 connection component 100 comprising the plug body 500 inter-fitted with the plug cap 200 and showing the phase earth tube insulator 400 extending through the plug body 500 and the plug cap 200. The plug body 500, plug cap 200,

- 13 -

and phase earth tube insulators 400 fill approximately 50% of the internal region of the housing measuring from the connection end 110 that would not otherwise be filled with the electrical conductors 104a, 104b and/or any associated flame paths. It will be appreciated that the plug body 500, plug cap 200, and phase earth tube insulators 400 may fill approximately 10% or less, 20% or less, 30% or less, 40% or less, 50% or less, 60% or less, 70% or less, 80% or less, 90% or less, or 100% or less of the internal region of the housing measuring from the connection end 110 that would not otherwise be filled with the electrical conductors 104a, 104b and/or any associated flame paths.

Figure 7 shows a flowchart of a method 700 of forming the electrical connection component 100. In a first step 702 of the method 700, the housing 106, the electrical conductors 104a, 104b and the electrically insulating components 200, 300, 400 are provided. In a second step 704, the insulating components 200, 300, 400 are form-fit with one another such that a majority of the internal region of the housing 106 that is located towards the connection end 110 of the housing 106, and that would not otherwise be filled with the electrical conductors 104a, 104b, is filled by the electrically insulating components 200, 300, 400.

It will be understood by persons skilled in the art of the invention that many modifications may be made without departing from the spirit and scope of the invention.

30

In the claims which follow and in the preceding description of the invention, except where the context requires otherwise due to express language or necessary

- 14 -

implication, the word "comprise" or variations such as "comprises" or "comprising" is used in an inclusive sense, i.e. to specify the presence of the stated features but not to preclude the presence or addition of further
5 features in various embodiments of the invention.

CLAIMS:

1. An electrical connection component for a machine cable, the electrical connection component being suitable for transmission of power with voltage levels greater than or equal to 1 kV, the electrical connection component comprising:

at least one electrical conductor being arranged for electrically coupling with a further electrical conductor of another electrical connection component;

a housing having an internal region, and having a machine cable end and a connection end; and

at least two electrically insulating components positioned within the housing and each component being arranged to form-fit with an inner surface of the housing and with at least a further electrically insulating component in a predefined orientation; wherein

a first component of the at least two electrically insulating components is positioned at a connection end of the housing and a second component of the at least two electrically insulating components is positioned between the first component and the machine cable; and

a portion of the internal region of the housing that is located at the connection end of the housing, and that would not otherwise be filled with the at least one electrical conductor and/or an associated flame

path, is filled by the at least two electrically insulating components, and the further electrically insulating component,

wherein at least one of the electrically insulating components comprises a passage for receiving the further electrically insulating component therewithin, and at least a portion of the passage is shaped such that the further electrically insulating component fits within the passage in a predefined orientation.

2. The electrical connection component of claim 1, wherein the electrically insulating components fill 10% or less, 20% or less, 30% or less, 40% or less, 50% or less, 60% or less, 70% or less, 80% or less, 90% or less, or 100% or less of the internal region of the housing measuring from the connection end that would not otherwise be filled with the at least one electrical conductor and/or an associated flame path.

3. The electrical connection component of claim 1, wherein the insulating components fills more than 70%, 80% or 90% of the internal volume of an internal portion of the housing.

4. The electrical connection component of claim 3, wherein the internal portion fills more than 90%, 80% 70%, 60%, 50% 40%, 30% or 20% of the internal volume of the housing.

5. The electrical connection component of any one of claims 1 to 4, wherein the at least two electrically insulating components are arranged such that the at least one conductor penetrates through each of the electrically insulating components.

6. The electrical connection component of any one of claims 1 to 5, wherein the first component has a protrusion having a particular shape, with the second component having a correspondingly shaped recess for receiving the protrusion of the first electrically shaped recess wherein, when the first component is received in the second component, the first and second insulating components have a predefined orientation with respect to one another.

7. The electrical connection component of any one of claims 1 to 6, comprising an electrically insulating component that is arranged so as to receive a plurality of other electrically insulating components, wherein at least one of the electrically insulating components surrounds at least a portion of the at least one conductor, the at least one conductor penetrating therethrough.

8. The electrical connection component of any one of claims 1 to 7, wherein the electrically insulating components comprise a polymeric material.

9. The electrical connection component of any one of claims 1 to 8, wherein the first and second components are arranged to receive at least one third component through at least a portion of each of the first and second electrically insulating components.

10. The electrical connection component of claim 9, wherein the first and second electrically insulating components comprise respective passages that are aligned so as to receive the third electrically insulating component

therethrough.

11. The electrical connection component of claim 9 or claim 10, wherein the respective passages of the first and second electrically insulating components, and the at least one third electrically insulating component, are arranged such that the at least one third electrically insulating component form-fits with the first and second electrically insulating components.

12. The electrical connection component of any one of claims 9 to 11, wherein the at least one third component comprises a flange having a particular shape, the first or the second component comprising a recess having a shape corresponding to that of the flange of the third electrically insulating component such that the third electrically insulating component can only be arranged through the first and second electrically insulating components in one orientation.

13. The electrical connection component of any one of claims 9 to 12, wherein the at least one third electrically insulating component comprises a tube that is arranged for receiving the at least one electrical conductor, the tube comprising a first material comprising an insulating material, the first material surrounding a length of the at least one electrical conductor that has been received by the tube, and a second material comprising a conductive material arranged to be electrically couplable to an earth of the machine cable, the second material surrounding the first material substantially along a length of the third component.

14. The electrical connection component of any one of claims 9 to 13, wherein the first and second components are substantially cylindrically shaped.

15. A method of forming an electrical connection component, the electrical connection component being in accordance with any one of claims 1 to 14, the method comprising the steps of:

providing the housing, the at least one electrical conductor, and the at least two electrically insulating components; and

form-fitting at least one of the electrically insulating components with a further one of the electrically insulating components and with an inner surface of the housing in a predetermined orientation such that a portion of the internal region of the housing that is located at the connection end of the housing, and that would not otherwise be filled with the at least one electrical conductor and/or an associated flame path, is filled by the electrically insulating components.

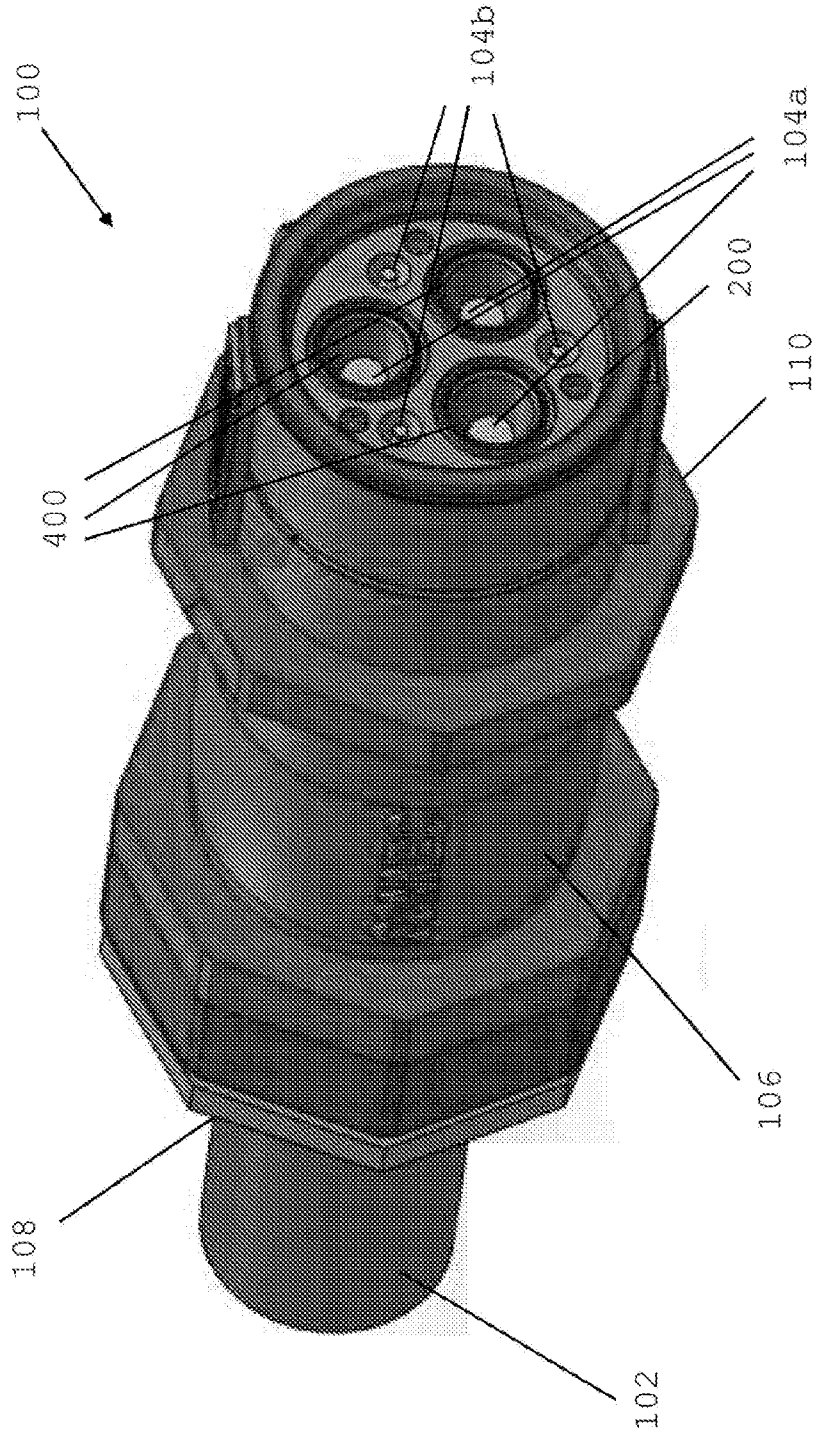

FIGURE 1

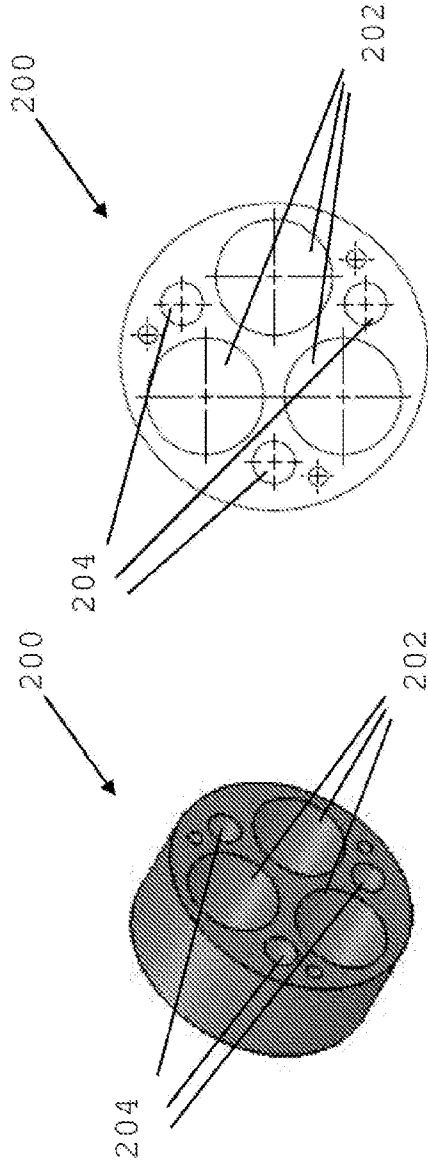

FIGURE 2(b)

FIGURE 2(a)

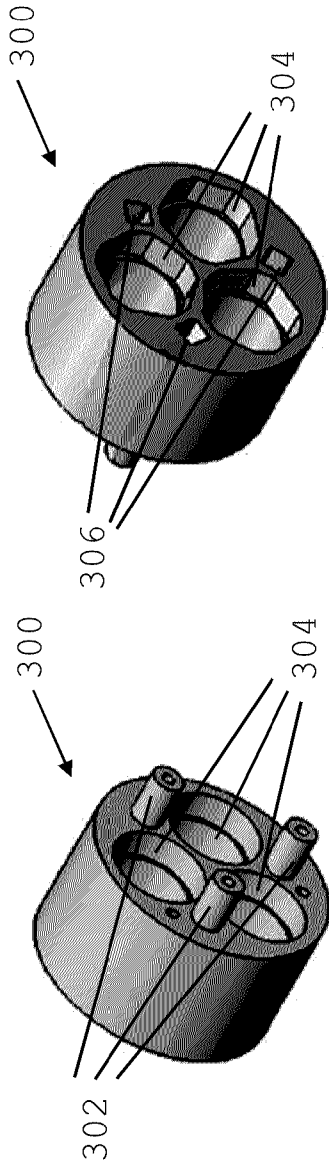

FIGURE 3(a)

FIGURE 3(b)

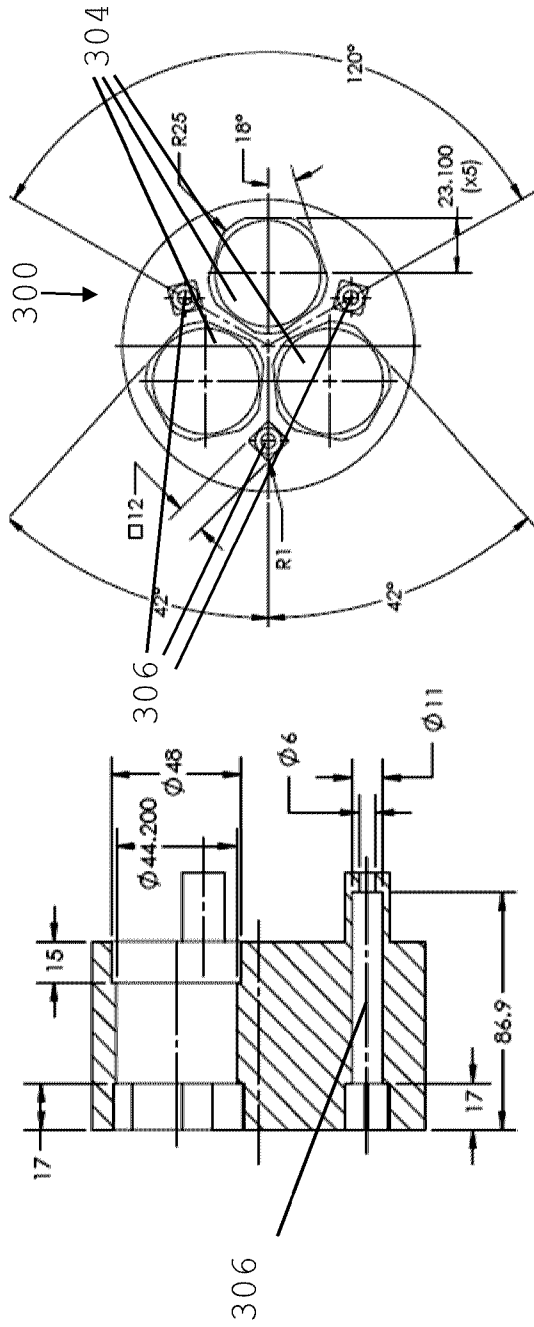
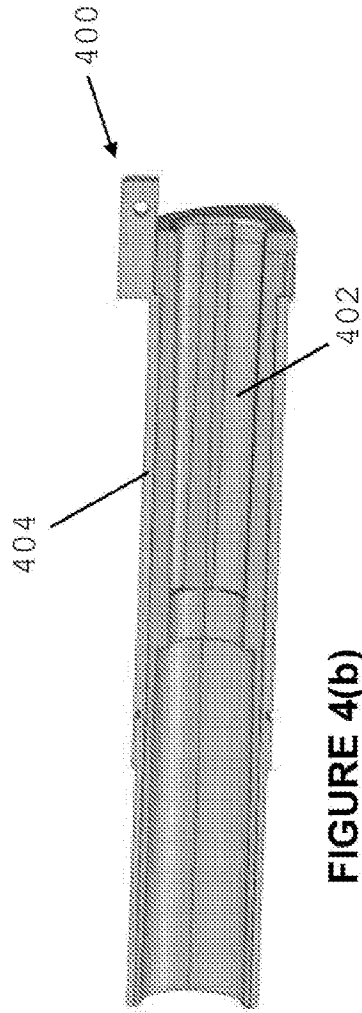
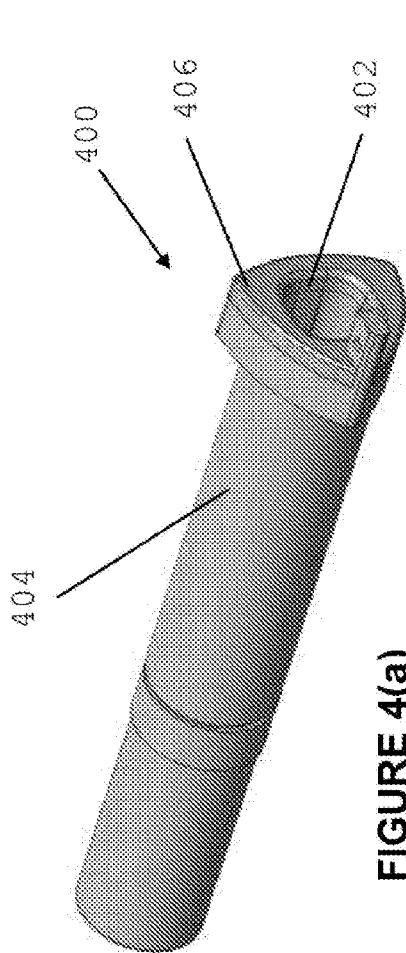

FIGURE 3(c)

FIGURE 3(d)



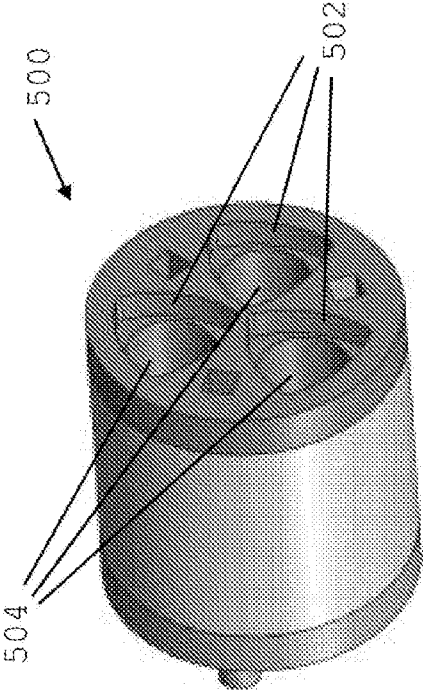

FIGURE 5

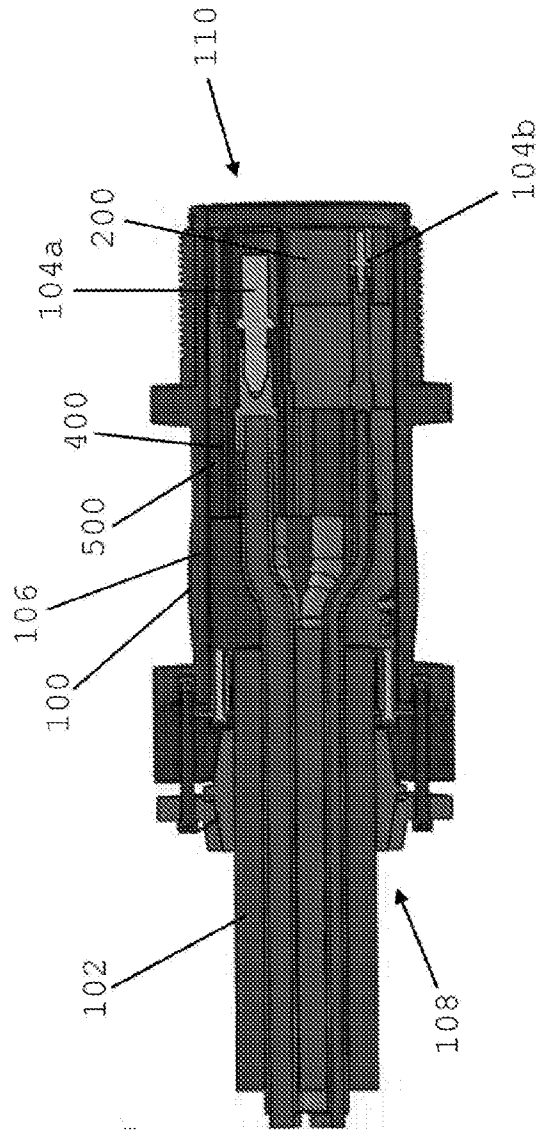
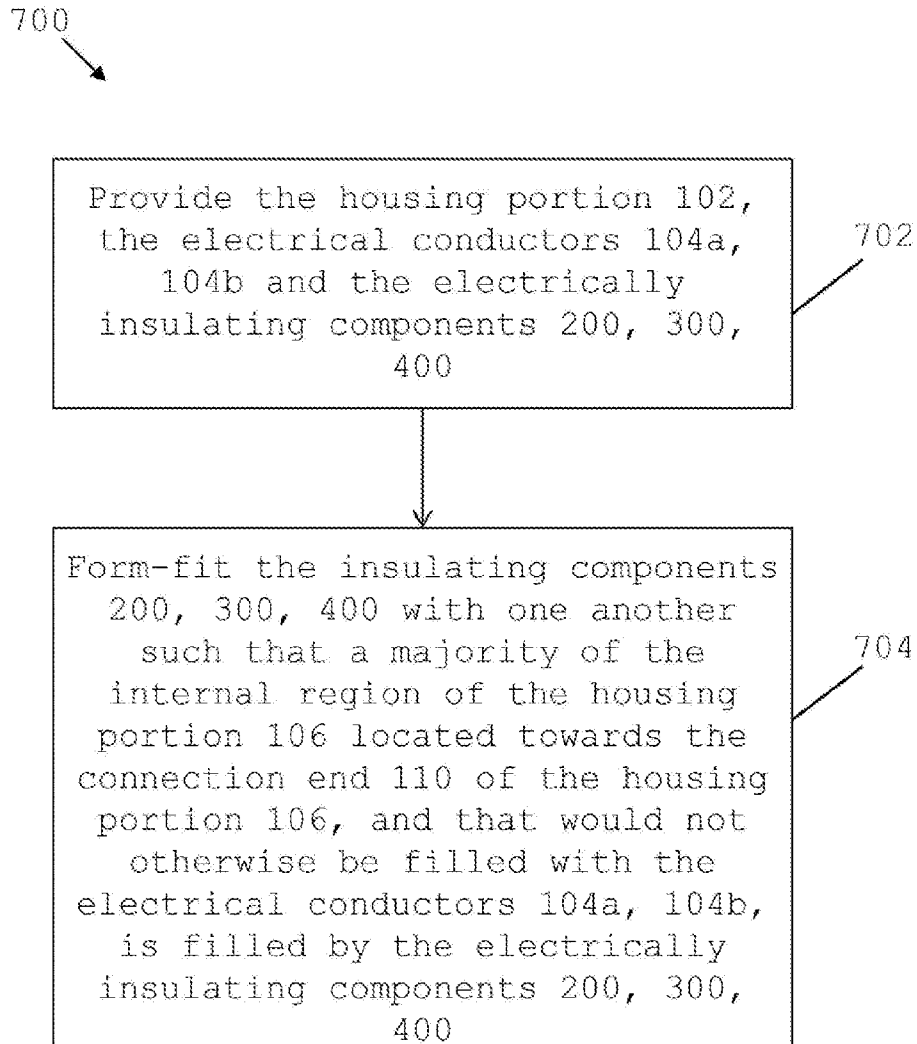

FIGURE 6

7/7

**FIGURE 7**

