

E. F. WOODBURY.

MACHINE FOR SAWING RATTAN.

No. 190,109.

Patented April 24, 1877.

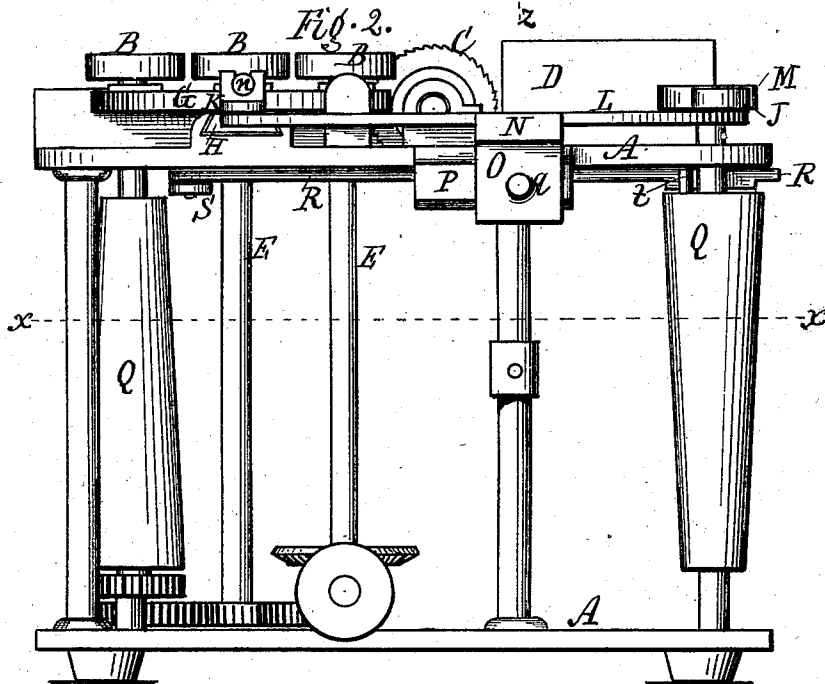
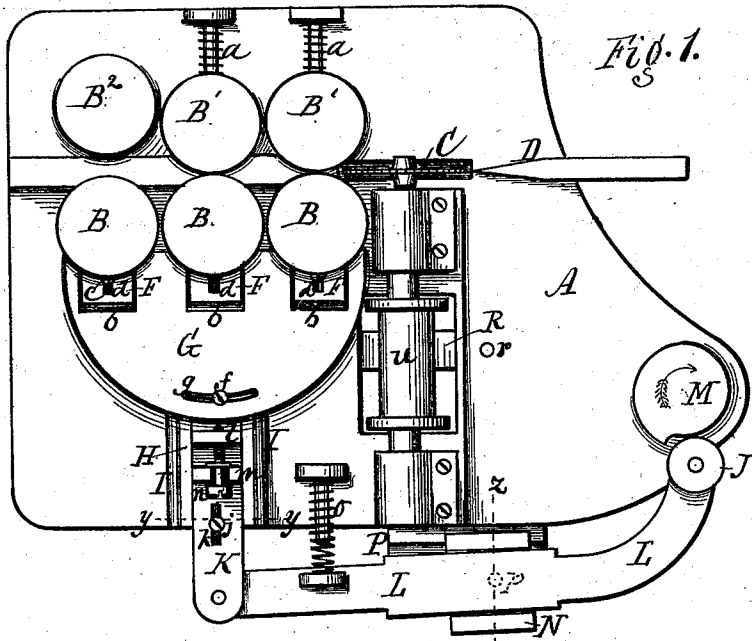

Attest.
Louis Spahn
R. E. White

Inventor.
Edmund F. Woodbury,
per R. F. Ozgood,
Atty.

E. F. WOODBURY.

MACHINE FOR SAWING RATTAN.

No. 190,109.

Patented April 24, 1877.

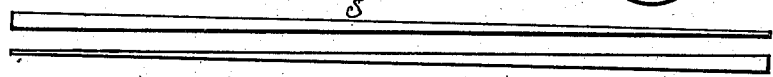
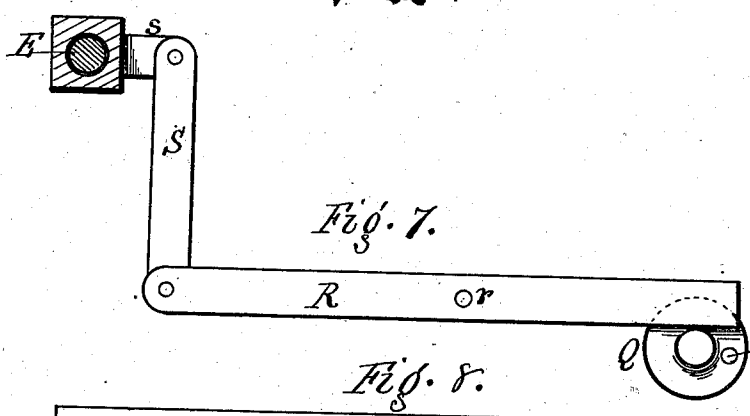
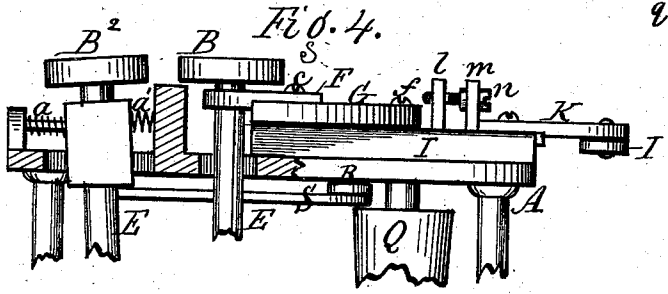
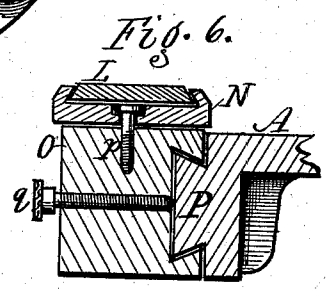
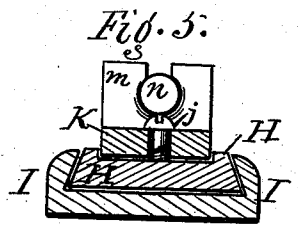
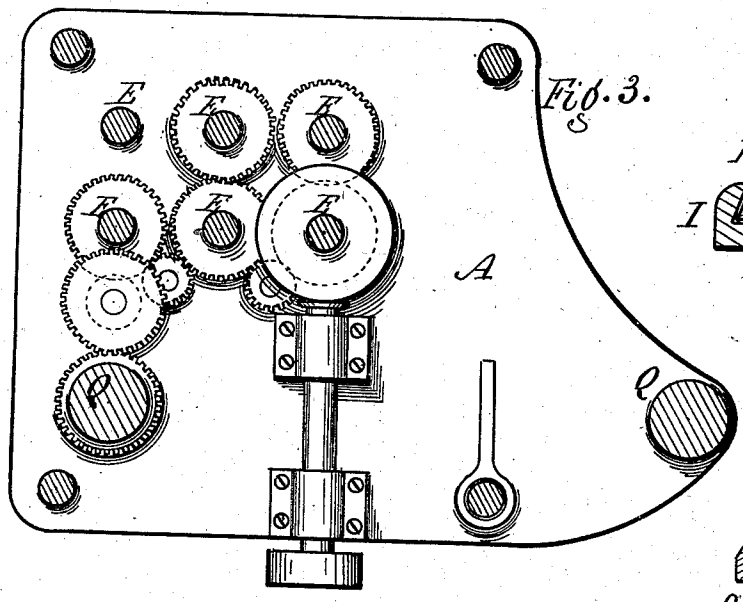

Attest.
 Louis Spahn.
 R. E. White

Inventor.
 Edmund F. Woodbury,
 per R. F. Osgood,
 atty.

UNITED STATES PATENT OFFICE.

EDMUND F. WOODBURY, OF ROCHESTER, NEW YORK.

IMPROVEMENT IN MACHINES FOR SAWING RATTAN.

Specification forming part of Letters Patent No. **190,109**, dated April 24, 1877; application filed January 31, 1877.

To all whom it may concern:

Be it known that I, EDMUND F. WOODBURY, of the city of Rochester, in the county of Monroe and State of New York, have invented certain new and useful Improvements in Machines for Sawing Rattan; and I do hereby declare that the following is a full, clear, and exact description of the construction and operation of the same, reference being had to the accompanying drawings, in which—

Figure 1 is a plan of the machine. Fig. 2 is a side elevation. Fig. 3 is a section in line *xx* of Fig. 2. Fig. 4 is a sectional elevation of the upper portion of the machine, looking at right angles to Fig. 2. Fig. 5 is a cross-section in line *yy* of Fig. 1. Fig. 6 is a cross-section in line *zz* of Fig. 1. Fig. 7 is a plan of the lever-work for operating the closing-roller. Fig. 8 is a view of a stick of rattan divided angularly by my improved machine.

My improvement relates to a machine for dividing rattan for whips. The sticks have to be cut angularly in order to save stuff and produce the proper taper to the whip. Such work has usually been done by hand, which is very laborious and slow. It is the object of my improvement to do the work by machinery; and the invention consists in the combination and arrangement of parts hereinafter more fully described and definitely claimed.

A is the frame, which may be of any suitable form and construction. B B B and B¹ B¹ B² are a series of rollers arranged in two parallel lines, through which the rattan is fed to the dividing-saw C, which divides the same. D is a wedge-shaped divider, which spreads the ends of the rattan and divides the same in two separate lots, with the butts of each lot lying in the same direction. E E E are the shafts to which the rollers are attached, driven by suitable gearing, as shown in Fig. 3. Any gearing adapted to the purpose may be used. The outer roller of the line B¹ B¹ B² turns loosely on its shaft, and in its normal position it is thrown back by a spring, *a'*, so as to leave an open throat between it and the other tier of rollers for the entrance of the rattan, as shown in Fig. 1. It is thrown forward, to close upon the rattan, by means which will presently be described. The other two rollers, B¹ B¹, are pressed inward in the oppo-

site direction by springs *a*, thereby holding them firmly in contact with the opposing rollers; but they yield as the rattan passes through. The rollers B B B rest in boxes F F F, attached to a segment, G, which rests on top of the machine. The boxes F are adjustable in and out in slots *b b*, Fig. 1, by which means the rollers can all be properly adjusted in line in first setting up the machine. After being so adjusted in line they rarely need change. The segment is simply a flat plate, and as it is moved up or back it will be seen that all the rollers B B B will be moved with it bodily. The boxes F are held at any adjustment by screws *c*, passing through slots *d* into the body of the segment.

H, Figs. 1 and 5, is a carriage resting loosely and sliding in a way, I, fixed permanently on top of the frame, at right angles to the line of the rollers. The segment is attached to this carriage by a screw, *f*, which passes through a concentric slot, *g*, of the segment. This allows the segment to be swung in a circle around the center roller B, thereby adjusting or changing the line of the said rollers B B B to any desired angle. The other rollers B¹ B¹ B², by reason of being pressed up by springs, will adapt themselves to such angle. K is a slide resting and moving loosely in the carriage H, to which it is secured by a screw, *j*, passing through a slot, *k*. *l* and *m* are two standards projecting upward—one from the carriage H, and the other from the slide K; and these are connected by a screw, *n*, by turning which the two parts will be brought toward each other, thereby moving the segment forward or back. L is a rock-lever, pivoted at one end to the slide K, and carrying, at the other end, a roller, J, which rests against a cam, M. As this cam revolves, the roller is thrown out and in, and the lever is correspondingly rocked. *o* is a spring for producing the reaction of the rock-lever. N is a pivot-block, forming also a way to the rock-lever, which rests loosely therein. This block is pivoted at *p*, Fig. 6, to a carriage, O, which is adjustable forward and back on a way, P, secured to the side of the main frame. It is made fast at any adjustment by a set-screw, *q*. By this means it will be perceived that the throw of the rock-lever may be varied as

desired, since the carriage O and the pivot-block N, which form the fulcrum, can be moved forward or back, while the lever itself remains stationary, thereby changing the length of the arms of the lever. At the same time the pivoting of the block N allows free swinging of the lever. Consequently, the rollers B B B, through the medium of the slide K, carriage H, and segment G, will receive a corresponding motion.

Q Q are two cone-pulleys, around which passes a band. The cam M is attached to the end of one of these pulleys. By adjusting the band higher or lower on these pulleys, a slower or quicker revolution of the cam is produced, which is necessary to grade the action to the different lengths of rattan run through the machine—a short length requiring a quicker motion than a long one. It should be stated that rattan of the same length is run through the machine in quantity till a different length is required, rather than an indiscriminate feeding of different lengths at once. The cone-pulley at the opposite end from the cam connects with the gearing in any desired manner.

R is a rock-arm, pivoted at *r* to the bottom of the table. At one end it is pivoted to a connecting-arm, S, Fig. 7, which, in turn, is pivoted to a shank, *s*, of the shaft E, which carries the outer roller B². The other end projects past the upper end of the cone-pulley Q, that carries the cam. On the end of this pulley is a pin, *t*, which forms an eccentric. Once in every revolution of the pulley this pin strikes the rock-arm R and throws it out, thereby drawing the roller B² up to clamp the rattan between it and the opposing roller B, which then feeds the rattan between the other rollers, and the latter carry it up to the saw. The movement must be so graded that the outer roller B² will press up at proper time.

The saw is driven by a band acting on a pulley, *u*, on its arbor.

The operation is as follows: The rollers B B¹ are so adjusted by turning the screw *n* as to start the cut at the end of the rattan near one edge. Then, as the cut progresses, the rattan is caused to move laterally or crosswise of the line of cut by the gradual movement of the rollers B B B, caused by the cam M acting upon the roller J, and through it upon the rock-lever L, slide K, carriage H, and segment G. When the cut is finished it leaves the opposite end of the rattan at the edge opposite from where it started, thereby dividing the stick in two wedge-shaped pieces, as shown in Fig. 8.

In dividing large sticks it may be necessary to change the line of the rollers B B from a parallel to an angular position, so as to feed the stick at an angle to the saw. This is readily accomplished by turning the segment G on the center of the middle roller B, as before described.

One important feature in this invention is the disconnection and independent action of the rollers B B B and B¹ B¹ B², the one set being adjustable bodily and together to different positions, and the other set being so pressed up by springs as to adapt themselves to the position of the first. The machine constructed as above described is much more effective than hand-labor.

The rattan, when divided by the saw, is finished on the cut surface, and requires no further manipulation, as is required when split by a knife.

Having thus described my invention, what I claim herein as new is—

1. The combination, with the rollers B¹ B¹, pressed up by springs against the feeding-rollers B B, of the outer roller B², pressed out by a spring in the opposite direction, to open the throat for the entrance of the rattan, and connected with suitable mechanism to be closed upon the rattan, as shown and described, and for the purpose specified.

2. In a machine for sawing rattan, the combination, with the feeding-rollers B B B, of segment G, capable of a swinging or turning movement to vary the position of the rollers, as shown and described, and for the purpose specified.

3. The combination of the carriage H, slide K, and the rock-lever L with the segment G, for producing a motion of the feeding-rollers B B B at right angles to the cut, and allowing lateral adjustment of said rollers, as shown and described, and for the purpose specified.

4. The combination, with the rock-lever L, of the pivoted block N, through which the rock-lever moves freely, and the carriage O, for adjusting the block, as shown and described, and for the purpose specified.

In witness whereof I have hereunto signed my name in the presence of two subscribing witnesses.

EDMUND F. WOODBURY.

Witnesses:

R. F. OSGOOD,
EDWIN SCOTT.