

[72] Inventor **Leslie Perhacs, Jr.**  
 Topanga, Calif.  
 [21] Appl. No. **828,633**  
 [22] Filed **May 28, 1969**  
 [45] Patented **May 25, 1971**  
 [73] Assignee **Cragstan Industries, Inc.**  
 New York, N.Y.

3,010,252 11/1961 Crawford et al. .... 46/98

OTHER REFERENCES

Sidney A. Tarrson Co. Publication, March 10, 1966

Primary Examiner—Louis G. Mancene  
 Assistant Examiner—Jack Q. Lever, Jr.  
 Attorney—Burton L. Lilling

[54] **KALEIDOSCOPE PULL-TOY CONSTRUCTION**  
 19 Claims, 12 Drawing Figs.

[52] U.S. Cl. .... **46/103**  
 [51] Int. Cl. .... **A63h 11/10**  
 [50] Field of Search ..... 46/97, 98,  
 99, 103, 106, 114, 220, 202

[56] **References Cited**  
**UNITED STATES PATENTS**  
 2,437,442 3/1948 Siwiec ..... 46/99

**ABSTRACT:** The present invention pertains to a pull-toy construction employing a horizontally disposed kaleidoscope assembly wherein there is provided means for translating the rotational movement of the wheels of the toy about a horizontal axis into rotational movement of the kaleidoscope assembly about a vertical axis, and including means for translating the wheel rotation about a horizontal axis into movement of other parts of the toy with various movement patterns in various planes of motion, and for also producing audible effects in combination therewith.

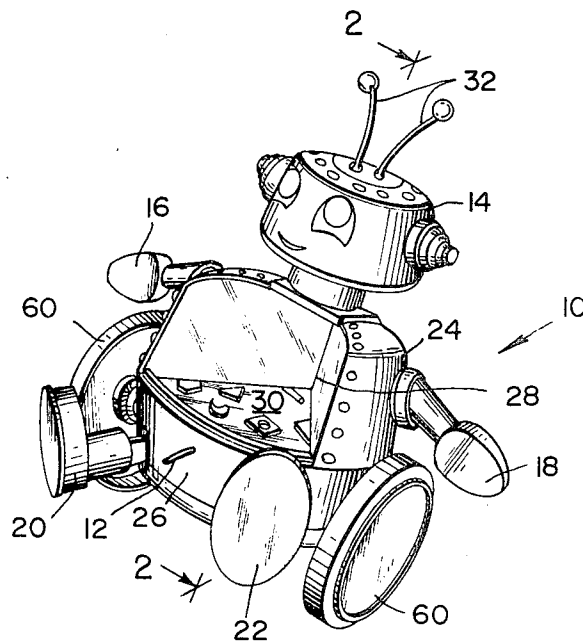

FIG. 1

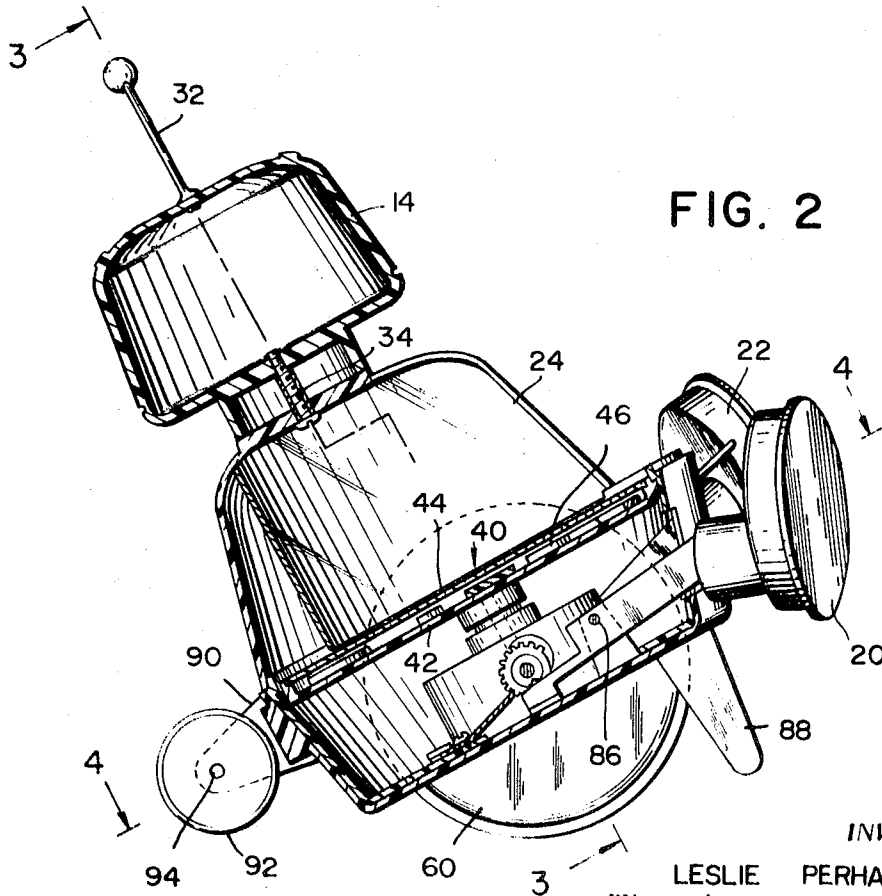
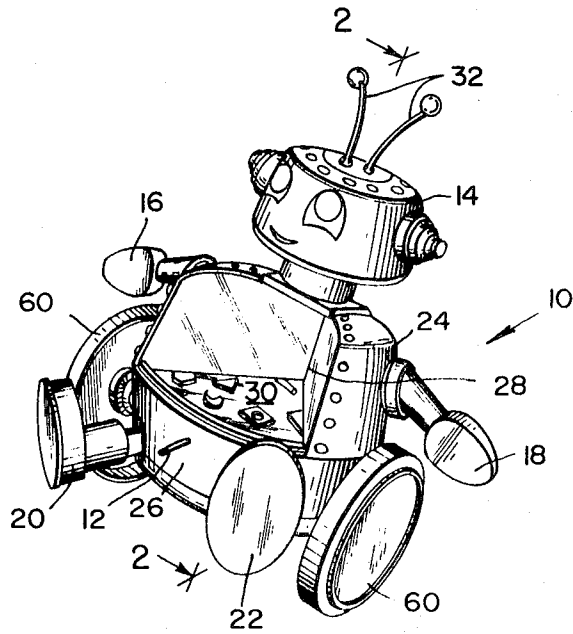

FIG. 2

INVENTOR.

LESLIE PERHACS, Jr.

*Substantive Patenting*

ATTORNEY

FIG. 3

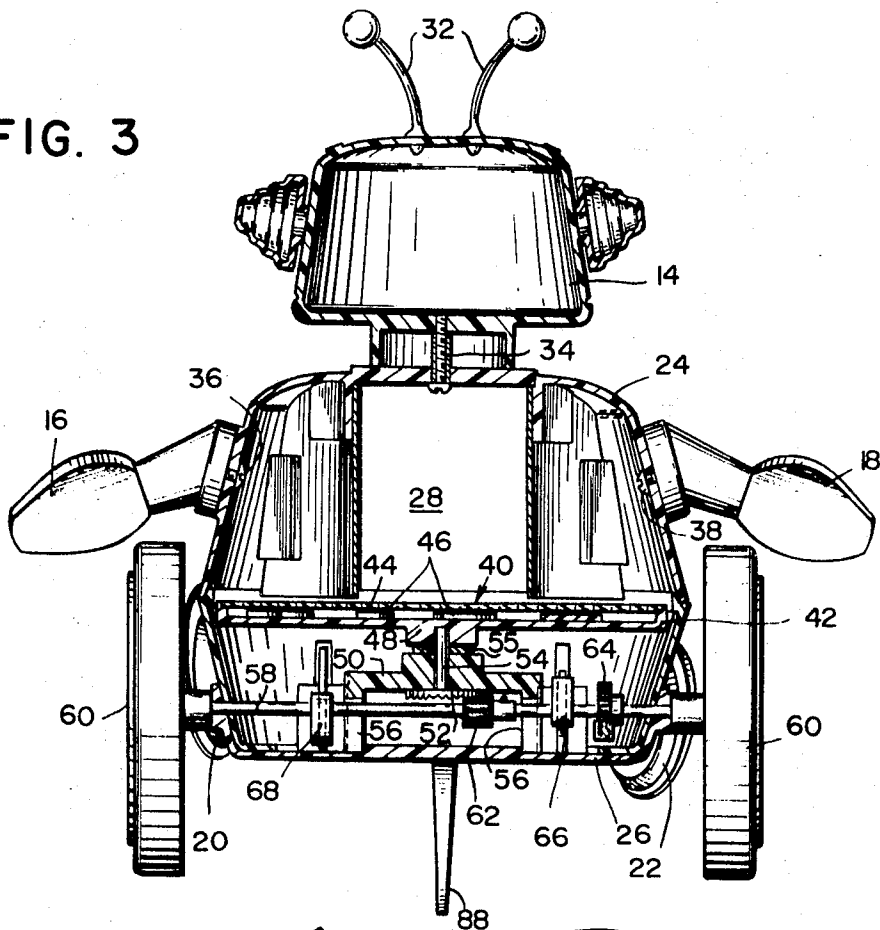
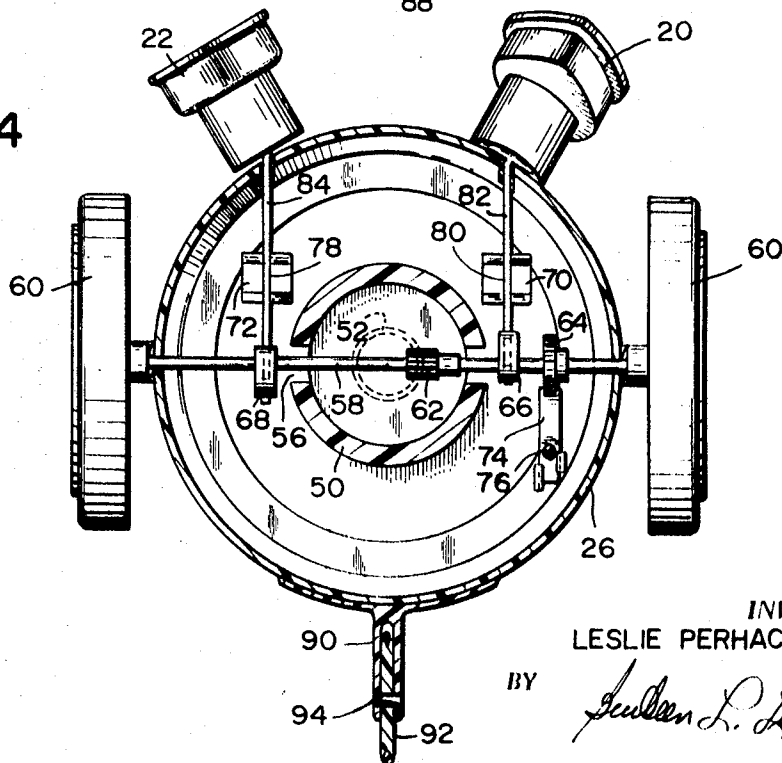

FIG. 4



INVENTOR.  
LESLIE PERHACS, Jr.

BY

*Seubert D. Belling*

ATTORNEY

FIG. 5

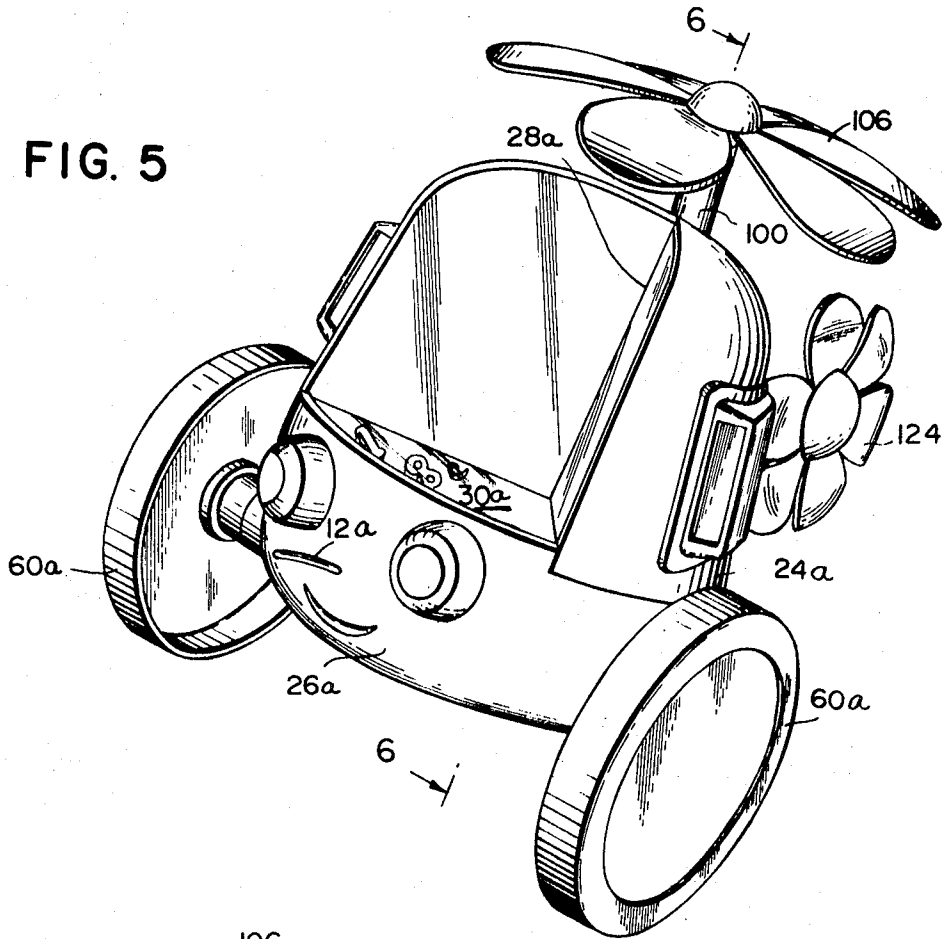
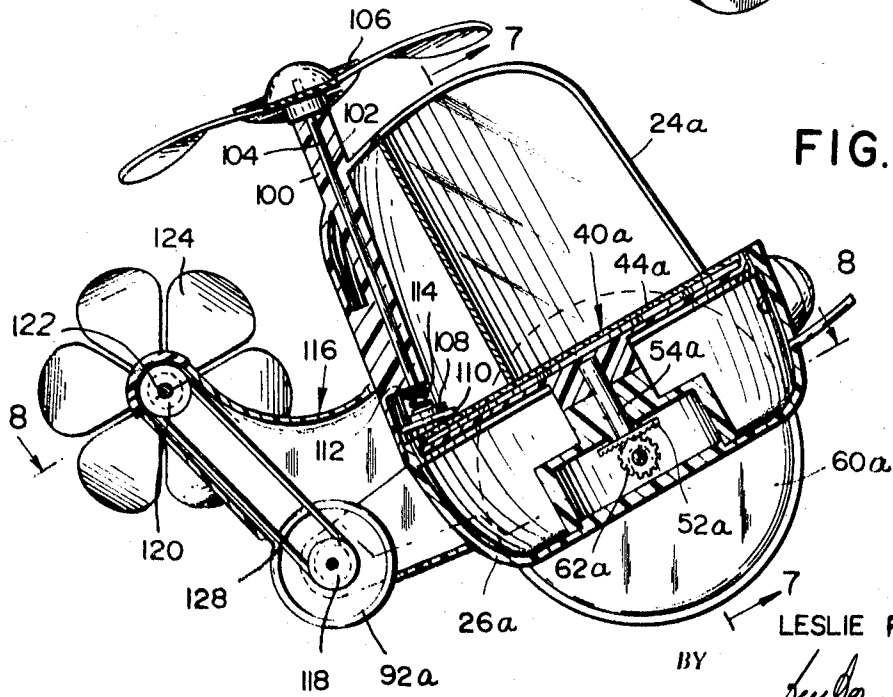

FIG. 6



INVENTOR.  
LESLIE PERHACS, Jr.

BY *Seaman L. Halling*  
ATTORNEY

FIG. 7

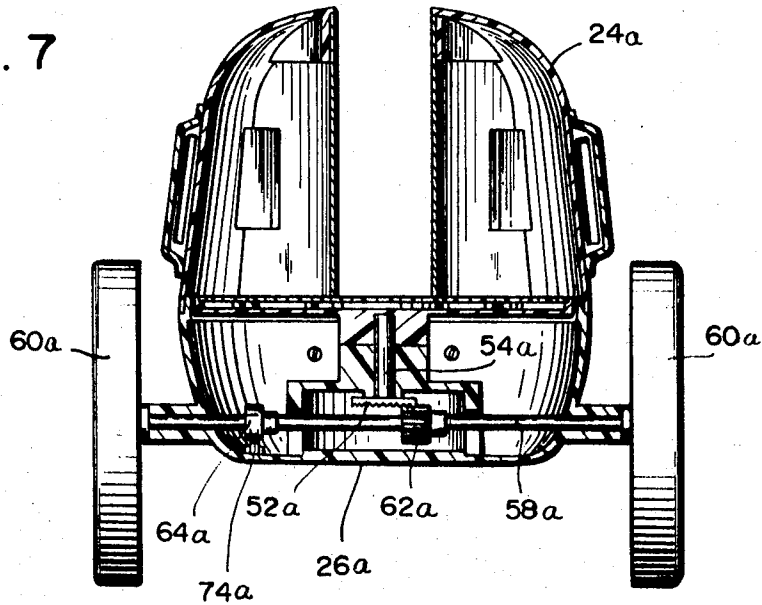
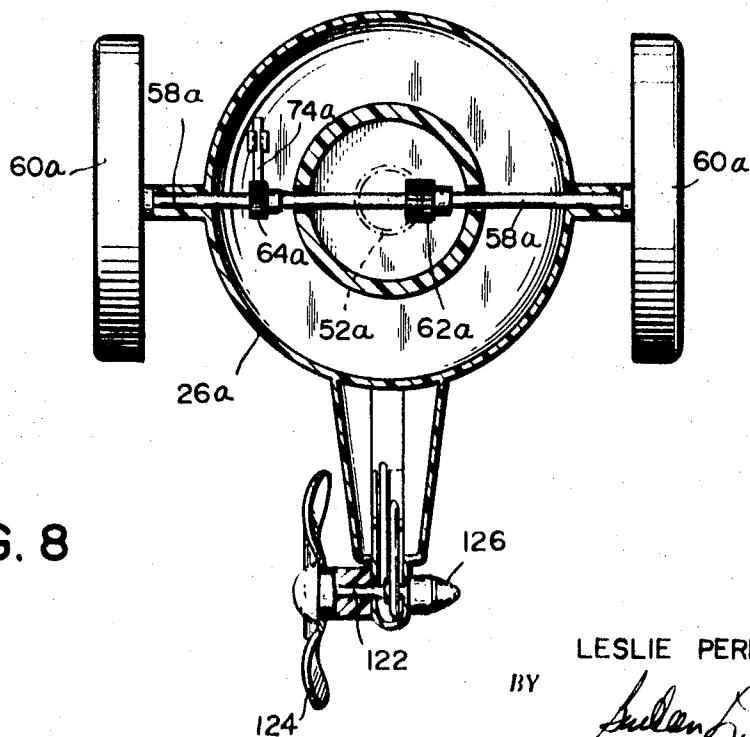

FIG. 8



INVENTOR.  
LESLIE PERHACS, Jr.

BY

*Andrew P. Halling*

ATTORNEY

FIG. 9

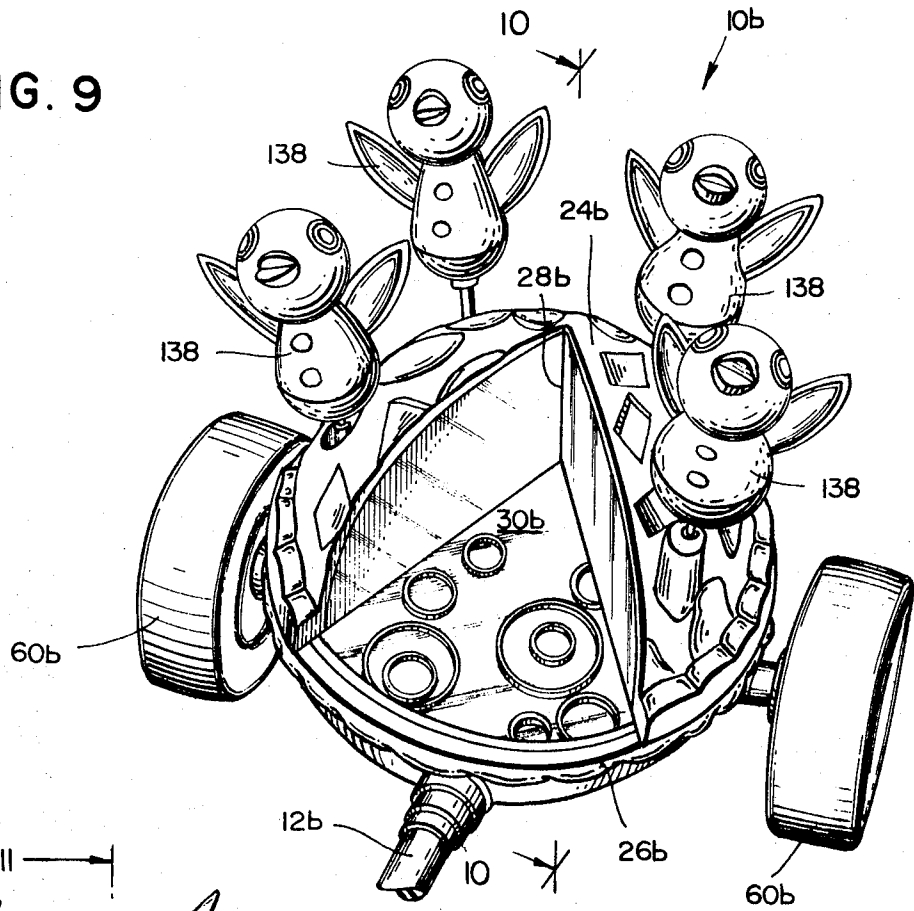
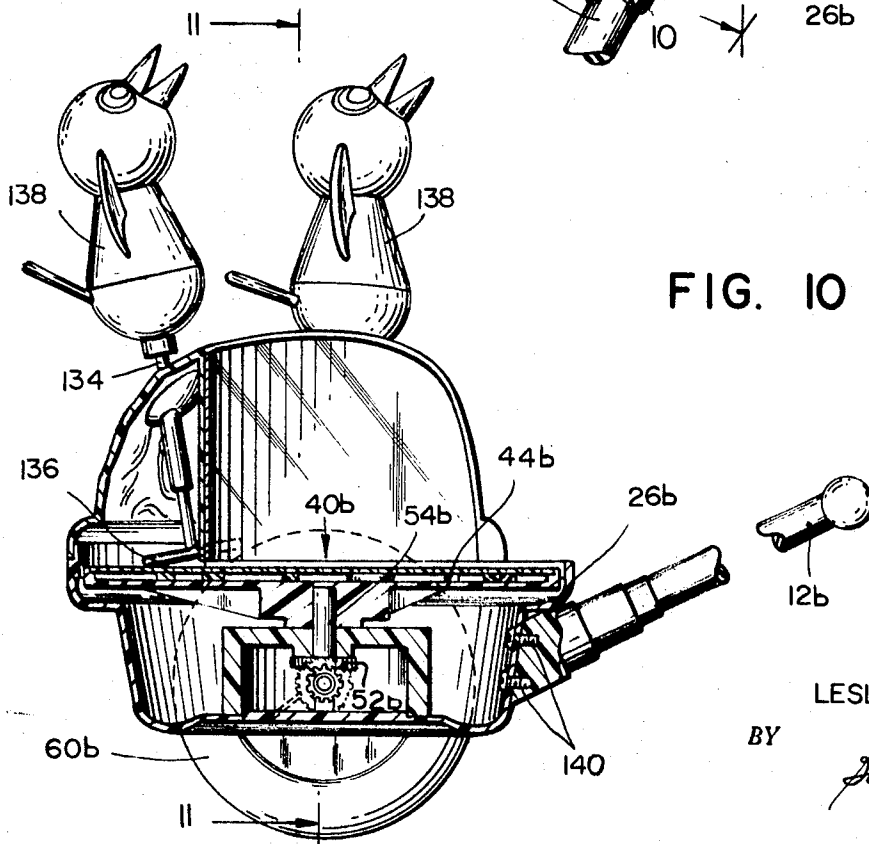

FIG. 10



INVENTOR.  
LESLIE PERHACS, Jr.

BY

*Richard D. Polling*  
ATTORNEY

FIG. II

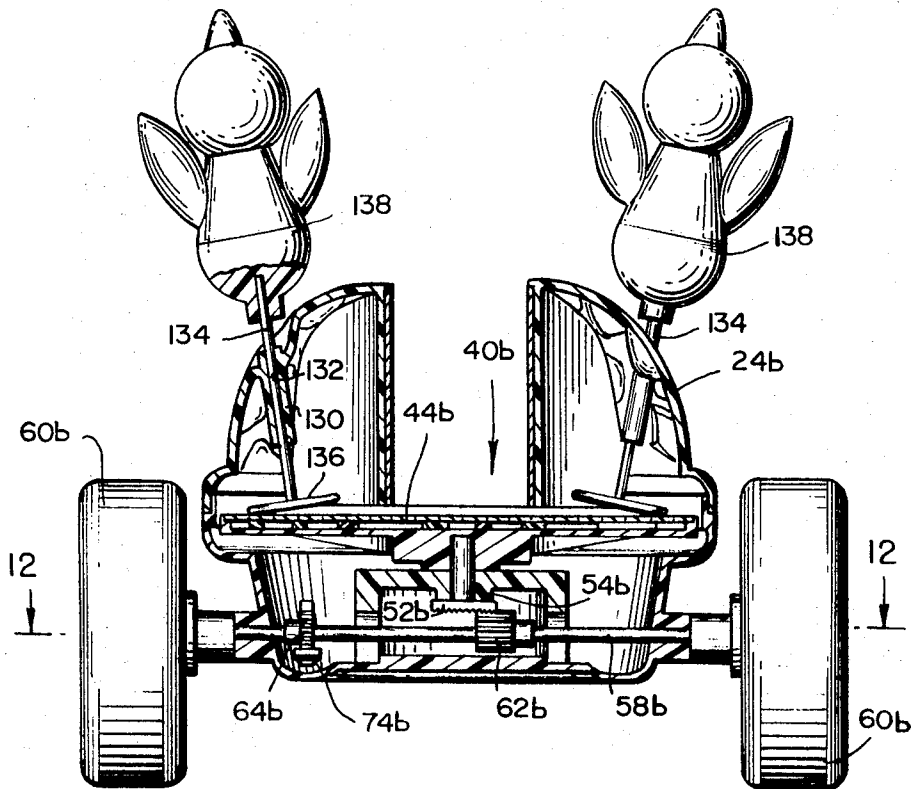
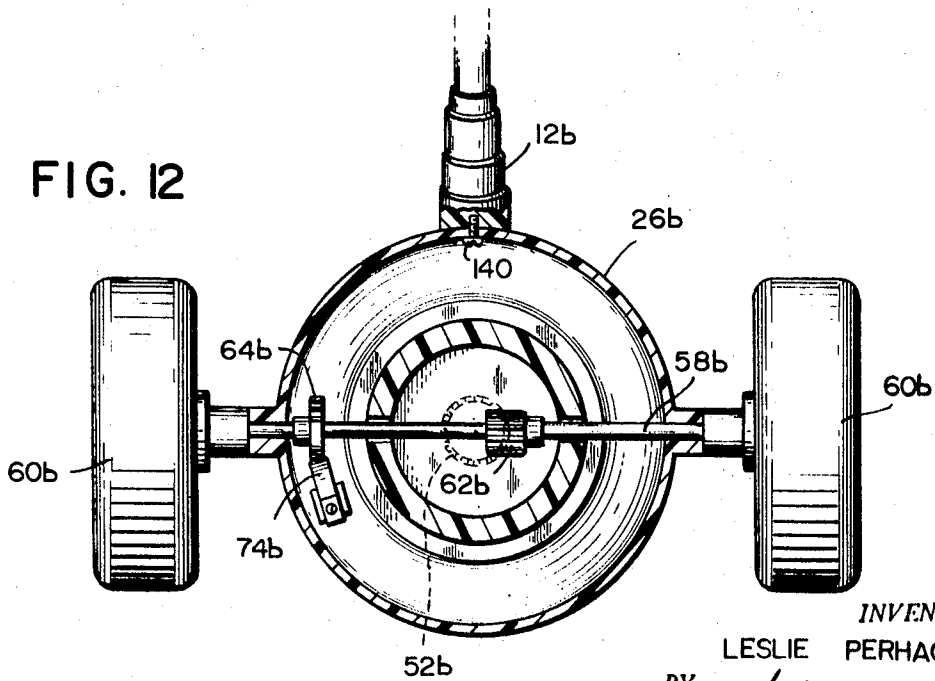

FIG. 12



INVENTOR.  
LESLIE PERHACS, Jr.  
BY *Richard L. Dilling*  
ATTORNEY

## KALEIDOSCOPE PULL-TOY CONSTRUCTION

## BACKGROUND OF THE INVENTION

The present invention is directed to a new and novel pull-toy construction having a kaleidoscope assembly and adapted to produce movement of the kaleidoscope and other members of the toy upon rotational movement of the wheels thereof about a horizontal axis whereby there is produced a combination of visual and audible effects which will provide a source of amusement to children and which will keep them happily occupied for extended periods of time, thereby resulting in a great deal of pleasure being imparted to the children, and to their parents.

## SUMMARY

It is, therefore, the primary object of the present invention to provide a new and novel pull toy which will produce various movements of the component members of the toy upon rotational movement of the wheels thereof about a horizontal axis.

It is another object of the present invention to provide a pull toy having a kaleidoscope assembly which is rotatable about a vertical axis upon rotational movement of the wheels of the pull toy about a horizontal axis.

It is yet another object of the present invention to provide a pull toy of the aforescribed type having a humanoid configuration wherein selected parts of the representative anatomy are movable upon rotational movement of the wheels of the pull toy.

It is a further object of the present invention to provide a pull toy of the type described which has a humanoid configuration wherein selected ones of the limbs are moveable upon rotational movement of the wheels of the pull toy.

It is still another object of the present invention to provide a pull toy of the aforescribed type which has a helicopter configuration having representative parts thereof moveable upon rotational movement of the wheels of the pull toy.

It is yet a further object of the present invention to provide a pull toy of the above described type which is representative of nursery rhymes and more particularly of four blackbirds wherein the blackbirds are adapted for rotational movement about a vertical axis upon the rotational movement of the wheel of the toy about a horizontal axis.

It is yet another object of the present invention to provide a pull toy of the aforescribed type having means for providing audible effects in conjunction with the movement of the various components thereof and which audible effects are dependent upon the rotational movement of the wheels of the toy.

It is still a further object of the present invention to provide a new and novel pull toy construction employing a kaleidoscope assembly which is aesthetically pleasing and relatively easy and inexpensive to manufacture.

## BRIEF DESCRIPTION OF THE DRAWINGS

These and other objects, features, advantages and embodiments of the present invention will become more apparent from the detailed description hereinafter considered in conjunction with the accompanying drawings wherein:

FIG. 1 is a perspective view of a first embodiment of a kaleidoscopic pull toy construction having a humanoid configuration and fabricated in accordance with the principles of the invention;

FIG. 2 is a partial sectional elevational view of the kaleidoscopic pull toy construction depicted in FIG. 1, taken on the line 2-2 thereof;

FIG. 3 is a partial sectional elevational view of the pull toy construction taken on the line 3-3 of FIG. 2;

FIG. 4 is a partial sectional view of the pull toy construction taken on the line 4-4 of FIG. 2;

FIG. 5 is a perspective view of a kaleidoscopic pull toy construction fabricated in the representative form of a helicopter and comprising a second embodiment of the present invention;

FIG. 6 is a partial sectional elevational view of the kaleidoscopic pull toy construction depicted in FIG. 5, taken on the line 6-6 thereof;

FIG. 7 is a partial sectional elevational view of the pull toy construction taken on the line 7-7 of FIG. 6;

FIG. 8 is a partial sectional view of the pull toy construction taken on the line 8-8 of FIG. 6;

FIG. 9 is a perspective view of a third embodiment of the invention employing a plurality of blackbirds rotatable in conjunction with a kaleidoscope assembly;

FIG. 10 is a partial sectional elevational view of the pull toy construction taken on the line 10-10 of FIG. 9;

FIG. 11 is a partial sectional elevational view of the pull toy construction taken on the line 11-11 of FIG. 10; and

FIG. 12 is a partial sectional view taken on the line 12-12 of FIG. 11.

## DESCRIPTION OF THE PREFERRED EMBODIMENTS

Referring now to the drawings and more particularly to FIG. 1 thereof, there is shown a kaleidoscopic pull toy construction generally designated by the reference numeral 10 and fabricated in accordance with the principles of the present invention and comprising a first embodiment having a humanoid configuration.

The toy 10 includes a string 12 for pulling the same preferably upon a flat horizontal surface.

The toy is of a generally cylindrical configuration and includes a head 14, arms 16 and 18, legs 20 and 22, an upper body portion 24 and a lower body portion 26. The upper body portion 24 has an arcuate cutout portion 28 in the front thereof which exposes a pie-shaped segment 30 of the upper surface of the lower body portion.

The upper and lower body portions 24 and 26, respectively, are preferably made of plastic and are secured with respect to one another by cementing or by any other suitable method of connection.

The head 14 includes a pair of antennae 32 and is secured to the upper surface of the upper body portion 24 by means of a screw 34, as best seen in FIG. 2. Similarly, the arms 16 and 18 are secured to the sides of the upper body portion 24 by means of screws 36 and 38, respectively, (as shown in FIG. 3).

The bottom portion 26 includes a kaleidoscope assembly generally designated by the reference numeral 40, disposed at the upper end thereof. The kaleidoscope assembly 40 includes a substantially cylindrical housing 42 having a plastic transparent cover 44 mounted thereon as by means of a snap-in engagement. Disposed within the housing 42 beneath cover 44 are a plurality of freely moveable members or discs 46. The members 46 are preferably of various colors and shapes so as to present a pleasant, attractive and attention drawing visual display.

The underportion of the housing 42, as viewed in FIG. 3, is formed with an integral boss 48.

Disposed within the body portion 26, there is also a hub 50 having a crown gear 52 positionally mounted for rotational movement with respect thereto. The crown gear 52 includes a vertically extending stem 54 which protrudes outwardly from the hub and whose upper end is secured within the boss 48, whereby the housing 42 is mounted for rotational movement in dependence upon the rotational movement of the crown gear 52, as will appear more fully hereinafter. The boss 48 may be spaced from the upper surface of the hub 50 as by a spacing washer 55.

The hub has a pair of lateral openings 56 formed therein, through which a shaft 58 extends; the ends of the shaft being secured to wheels 60 and adapted for rotational movement concomitantly therewith.

Fixedly secured to the shaft 58 are a spline gear 62, a clacker gear 64 and eccentric cams 66 and 68, each of which is rotational in dependence upon the rotation of the shaft 58.

Mounted within body portion 26 are pivot blocks 70 and 72 and a clacker 74. The clacker 74 is preferably a bent piece of

metal or plastic, one end of which is secured to the body portion 26 by means of a screw or rivet 76 and the other end of which engages the teeth of the clacker gear 64.

The pivot blanks 70 and 72 have recesses 78 and 80, respectively, formed therein. Connecting members 82 and 84 are disposed within the recesses 78 and 80, respectively, and pivotally secured by rivets 86 to the blocks 70 and 72, respectively, whereby the connecting members 82 and 84 are capable of movement in a vertical plane but are prevented from moving laterally or horizontally. The connecting members 82 and 84 have their outer ends secured to feet 20 and 22, respectively, and their inner ends act as cam followers by abuttingly engaging the offset eccentric cams 66 and 68, respectively.

The front lower part of the body portion 26 is provided with a vertically descending projection 88 which serves as a support member when the toy 10 is not being pushed or pulled. The rear part of the body portion is provided with a lateral projection 90 to which a rear wheel 92 is mounted for rotational movement by means of a rivet or stud 94.

In the operation of the toy 10, a child will pick up string 12 and commence to pull the toy. Upon pulling of the string 12, the rest member 88 is lifted away from the ground and the toy is then freely moveable by means of the wheels 60 and rear wheel 92. Rotational movement of the wheels 60 causes rotational movement of the shaft 58, whereupon the spline gear 62 rotates and meshingly engages the teeth of the crown gear 52 which, in turn, causes rotational movement of the gear 52 and its stem 54 about a vertical axis. The rotational movement of the stem 54 causes the kaleidoscope assembly 40 to also rotate about a vertical axis since the kaleidoscope assembly is secured to the stem 54 by the hub 48. The rotational movement of the kaleidoscope assembly 40 causes the free members 46 disposed therein to move in a random manner and to present a pleasing optical effect.

Concomitantly with the rotational movement of the wheels 60 about a horizontal axis, the clacker gear 64 rotates and engages the clacker 74 to provide an audible effect. More particularly, the clacker 74 engages the teeth of the gear 64 and upon rotational movement thereof provides a clickety-clack sound.

The rotational movement of the wheels 60 also causes rotational movement of the offset cams 66 and 68 which movement causes the inner ends of the members 82 and 84, acting as cam followers, to reciprocate in a vertical manner, thereby causing the feet 20 and 22 to move up and down.

It is thus seen that the rotational movement of the wheels 60 causes rotational movement of the kaleidoscope assembly 40, causes an audible clickety-clack effect and causes the feet 20 and 22 to reciprocally move up and down, all of the aforesaid occurring concomitantly. There is thus presented a new and novel toy having great interest and appeal to children.

It will, of course, be appreciated that the toy may also be made having the head 14 and the arms 16 and 18 moveable in conjunction with the rotational movement of the wheels 60. This could be accomplished by providing coupling means between the head 14, the arms 16 and 18 and the shaft 58. It will, of course, be appreciated that this would result in a much more complex toy; however, the above can be accomplished should the same be desirable. In a similar manner, the arms 16 and 18 may be made moveable in dependence upon the movement of the wheel 60 and the feet 20 and 22 may be made stationary. A various number of combinations and possible constructions will, of course, be apparent to those skilled in the art.

Another embodiment of the present invention is depicted by FIGS. 5 through 8, wherein similar parts are denoted by similar reference numerals.

Referring now to FIG. 5, there is shown a toy 10a having a helicopter configuration and including an upper body portion 24a, a lower body portion 26a, an arcuate cutout portion 28a, a pie-shaped segment 30a, a kaleidoscope assembly 40a, a crown gear 52a, a stem 54a, a shaft 58a, wheels 60a and a spline gear 62a.

The lower body portion 26a has decorations thereon which make the same appear as a face. The upper body portion 24a is provided with a vertical extension member 100 having a bore 102 therein which bore extends downwardly through the upper body portion. A rod 104 having a rotor or propeller member 106 secured to the upper end thereof is disposed within the bore 102. The propeller member 106 rests atop the extension member 100 while the lower end of the rod 104 projects through a washer 108 and is secured to a rubber wheel 110 and is rotationally moveable concomitantly therewith, as will appear more fully hereinafter.

The bottom portion of the vertical member 100 is disposed within the body portion 24a and forms a shoulder 112 with respect thereto. A spring 114 is interposed between the shoulder 112 and the washer 108 and serves to bias the rubber wheel 110 against the cover 44a in frictional engagement therewith.

The toy 10a is also provided with a laterally projecting tail assembly generally designated 116 which includes a rear wheel 92a having a hub 118. The tail assembly 116 includes a second hub 120 secured to the upper portion thereof by means of a pin or rivet 122 passing therethrough; the hub 120 is elevated with respect to the hub 118 and is secured to the pin 122. Secured to one end of the pin 122 is a tail rotor 124 and secured to the other end of the pin is a cap nut 126, which positionally secures the pin 122 with respect to the tail assembly 116. A belt 128 is positioned over the hubs 118 and 120 so that rotational movement of hub 118 imparts a rotational movement to hub 120.

The toy 10a is also provided with a clacker gear 64a and a clacker 74a.

In the operation of the toy 10a, the toy is pulled by means of string 12a which causes rotational movement of the wheels 60a and rear wheel 92a. Rotational movement of wheels 60a causes rotational movement of the shaft 58a and the spline gear 62a secured thereto, causing the spline gear 62a to meshingly engage the crown gear 52a, thereby causing the crown gear 52a, and its stem 54a secured thereto, to rotate about a vertical axis. Rotational movement of the stem 54a causes rotational movement of the kaleidoscope assembly 40a which, in turn, causes rotational movement of the rubber wheel 110 which is in frictional engagement therewith, and thus, of the rod 104 secured to the wheel 110 and, finally, of the rotor or propeller member 106.

The rotational movement of the wheel 92a causes rotational movement of the hub 118 which is translated into rotational movement of the hub 120 by means of the belt 128, thus causing rotational movement of the pin 122 to which the hub 120 is secured, and of the tail rotor 124 which is secured to the pin 122.

Thus, when the toy is pulled along a surface, the rotational movement of the wheels 60a and 92a will cause the rotor 106 and tail rotor 124 to rotate and this will be accompanied by an audible effect produced by the interaction of the clacker gear 64a and clacker 74a.

A third embodiment of the present invention is depicted by FIGS. 9 through 12, where again similar parts are denoted by similar reference numerals.

Referring to FIG. 9, there is shown a toy 10b having a substantially spherical configuration and including an upper body portion 24b, a lower body portion 26b, an arcuate cutout portion 28b exposing a pie-shaped segment 30b of a kaleidoscope assembly 40b. The toy 10b also includes a crown gear 52b, stem 54b, a shaft 58b, wheels 60b, a spline gear 62b, a clacker gear 64b and a clacker 74b.

The upper body portion 24b is formed with a plurality of vertical portions 130 having bores 132 therein. Rods 134 are disposed within the bores 132 and have rubber wheels or discs 136 secured to the bottom ends thereof while blackbirds 138 are mounted on the upper ends of the rods. It will be appreciated that although the present embodiment depicts birds 138 secured to the upper ends of the rods 134, any other type of decoration, animal, etc., may be used in lieu thereof.

The rubber wheels 136 are biased in frictional engagement with the cover 44b of the kaleidoscope assembly 40b by the weight of the blackbirds 138 alone, whereby the blackbirds are adapted to rotate about the vertical axis of the rods 134 in dependence upon the rotational movement of the kaleidoscope assembly.

The toy 10b is adapted to be pulled by means of a handle or rod 12b formed of a plurality of telescoping sections, the outermost one of which sections is secured to the bottom portion 26b by means of screws 140 or by any other suitable means.

As discussed hereinbefore, the rubber discs 136 are biased in frictional engagement with the cover member 44b of the kaleidoscope assembly solely by the weight of the blackbirds 138. The reason for this construction is that should a child grasp one of the blackbirds while the toy is moving, the disc 136 will be removed from the cover 44b and will not be rotationally driven thereby. Thus, the child can hold one of the blackbirds during the normal functioning of the toy without damaging the same.

In the operation of the toy 10b, the same is pulled along a surface by means of the handle 12b which has preferably been extended to its full length. The wheels 60b then rotate about a horizontal axis and cause the shaft 58b secured thereto to also rotate about a horizontal axis. The rotational movement of the shaft 58b causes, firstly, the clacker gear 64b to rotate against the clacker 74b to produce an audible effect, and, secondly, to rotate the spline gear 62b causing it to meshingly engage the crown gear 52b and causing it to rotate. The rotational movement of the crown gear results in a corresponding rotational movement of the kaleidoscope assembly 40b and its associated cover member 44b, whereupon the rubber wheels 136 are caused to rotate, resulting in rotational movement of the blackbirds 138.

It will be appreciated that the collapsible telescoping handle 12b provides an enjoyable feature to a child and also enables the toy to be stored in a relatively small space when not in use.

It will, of course, also be apparent to those skilled in the art that the toys hereinbefore described may be fabricated with a motor connected to the wheel shaft (58) so that the toys may be self-moveable by means of battery energy.

It will be apparent to those skilled in the art that although I have shown and described the preferred embodiments of my invention, there are many modifications, changes and improvements which can be made therein without departing from the spirit and scope thereof as defined in the appended claims.

I claim:

1. A toy adapted to move along a surface and comprising a body member, and at least two wheels, means for connecting said wheels to said body member to permit rotational movement of said wheels with respect to said body portion and for enabling said rotational movement of said wheels to propel said toy along said surface, said body member comprising an upper body portion, and a lower body portion, a kaleidoscope assembly, means securing said kaleidoscope assembly to said lower body portion, said upper body portion having a cutout portion which exposes a portion of said kaleidoscope assembly to viewing, means interconnecting said kaleidoscope assembly and said wheel connecting means for causing said kaleidoscope assembly to rotate concomitantly with the rotational movement of said wheels.
2. A toy in accordance with claim 1, including means operatively connected to said wheel connecting means for producing audible effects upon rotational movement of said wheels.
3. A toy in accordance with claim 1, wherein

said wheel connecting means includes a shaft extending horizontally through said lower body portion and having one of said wheels secured to each of the ends thereof, said shaft having a gear secured thereon intermediate the ends thereof, and

a crown gear fixedly secured to said kaleidoscope assembly and in meshing engagement with said gear, whereby rotational movement of said wheels and said shaft about a horizontal axis causes rotational movement of said crown gear and said kaleidoscope assembly about a vertical axis.

4. A toy in accordance with claim 3, wherein said gear secured on said shaft is a spline gear extending longitudinally thereon.

5. A toy in accordance with claim 3, wherein said body member has a humanoid configuration, said lower body portion having a pair of limbs connected thereto, and

means operatively connecting said limbs to said shaft for causing said limbs to reciprocate vertically in dependence upon rotational movement of said shaft.

6. A toy in accordance with claim 5, wherein said last mentioned connecting means includes a pair of connecting members each having one of the ends thereof connected to one of the limbs, respectively,

means for pivotally securing said connecting members to said lower body portion to permit vertical pivotal movement of said connecting members with respect to said lower body portion,

cam means secured on said shaft, and the other of the ends of said connecting members being disposed in proximity of said cam means and adapted to be engaged by said cam means to cause vertical reciprocating movement of said connecting members and, thus, of said limbs.

7. A toy in accordance with claim 6, wherein said cam means comprises two cams mounted in spaced apart relationship on said shaft,

said cams being mounted in opposite configuration on said shaft, whereby said connecting members, and said limbs connected thereto, are maintained in alternately opposite up and down relationship with respect to one another.

8. A toy in accordance with claim 7, wherein said lower body portion has a clacker secured thereto, a clacker gear secured on said shaft, said clacker abuttingly engaging said clacker gear and producing an audible effect concomitantly with the rotational movement of said shaft.

9. A toy in accordance with claim 3, wherein said upper body portion includes means disposed therewithin and in frictional engagement with said kaleidoscope assembly, and

said last mentioned means being rotatable about a vertical axis in dependence upon the rotational movement of said kaleidoscope assembly about a vertical axis.

10. A toy in accordance with claim 9, wherein said body member has a helicopter configuration, said rotatable means disposed within said upper body portion comprising a rod having a disc secured to the lower end thereof,

a rotor secured to the upper end of said rod, and bias means for biasing said disc in frictional engagement with said kaleidoscope assembly.

11. A toy in accordance with claim 10, wherein said bias means comprises a spring.

12. A toy in accordance with claim 11, wherein said lower body portion has a rear wheel and a tail assembly secured thereto,

said tail assembly being positioned at a raised elevation with respect to said rear wheel, said rear wheel having a hub secured thereto, said tail assembly including a tail rotor having a hub secured thereto, and

means for connecting said rear wheel hub to said tail assembly hub, whereby rotational movement of said rear wheel causes rotational movement of said tail rotor.

13. A toy in accordance with claim 12, wherein said lower body portion has a clacker secured thereto, a clacker gear secured on said shaft, and said clacker abuttingly engaging said clacker gear and producing an audible effect concomitantly with the rotational movement of said shaft. 5

14. A toy in accordance with claim 9, wherein said rotatable means disposed within said upper body portion comprises a plurality of rods positionally secured for rotational movement therewithin and each having a disc secured to the lower end thereof, and biasing means for biasing said discs in frictional engagement upon said kaleidoscope assembly. 10 15

15. A toy in accordance with claim 14, wherein said biasing means comprises a nursery rhyme character secured to the upper end of each of said rods. 20

16. A toy in accordance with claim 15, wherein said lower body portion has a clacker secured thereto, a clacker gear secured on said shaft, and said clacker abuttingly engaging said clacker gear and producing an audible effect concomitantly with the rotational movement of said shaft.

17. A toy in accordance with claim 3, wherein said kaleidoscope assembly comprises a housing having a transparent cover thereon, and said housing having a plurality of discs of various colors and various geometric configuration disposed therewithin.

18. A toy in accordance with claim 3, including means secured to said lower body portion for pulling and/or pushing said toy.

19. A toy in accordance with claim 18, wherein said last mentioned means comprises a handle having a plurality of telescoping sections.

20

25

30

35

40

45

50

55

60

65

70

75