

H. D. KNIGHT.

MACHINE FOR GRINDING AND POLISHING LENSES, &c.

No. 109,325.

Patented Nov. 15, 1870.

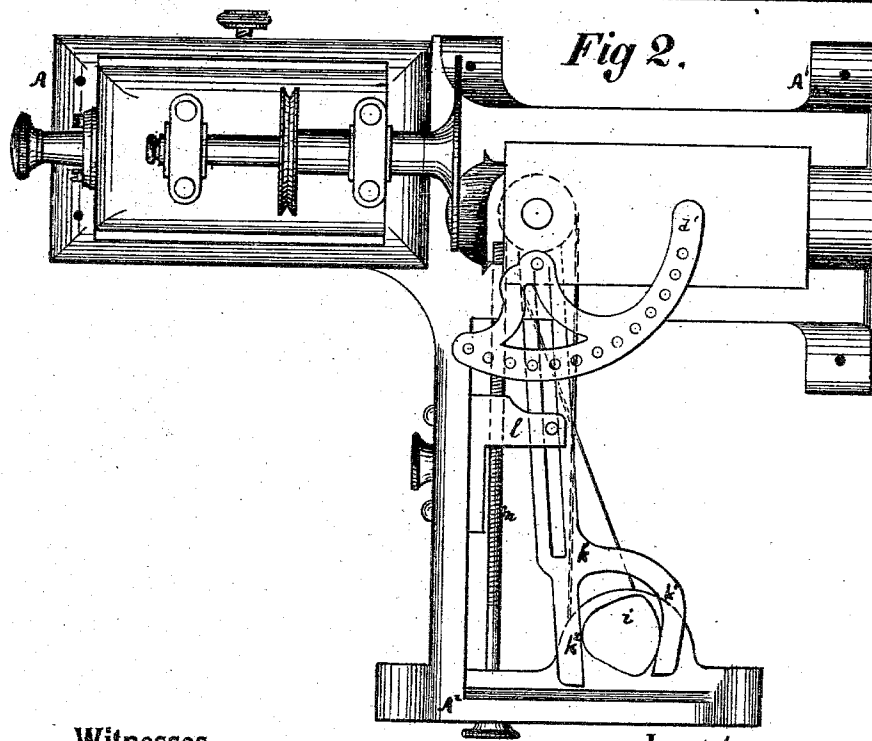
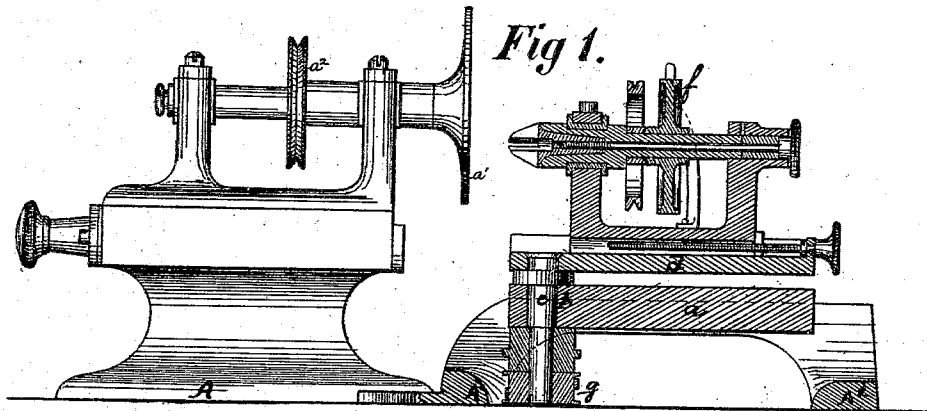

Witnesses.

S. J. Hoyle
D. P. Cowl

Inventor

H. D. Knight by
H. W. Beadle atty.

H. D. KNIGHT.
MACHINE FOR GRINDING AND POLISHING LENSES, &c.
No. 109,325. Patented Nov. 15, 1870.

Fig 3.

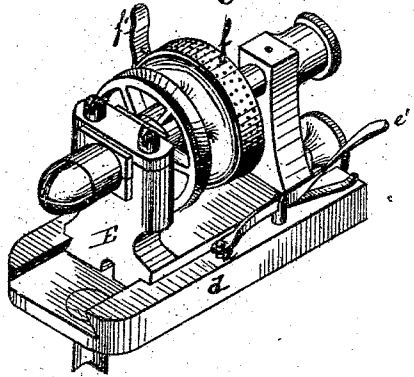

Fig 4.

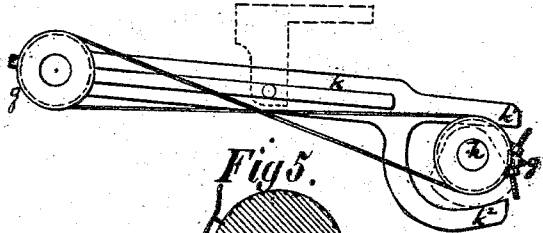
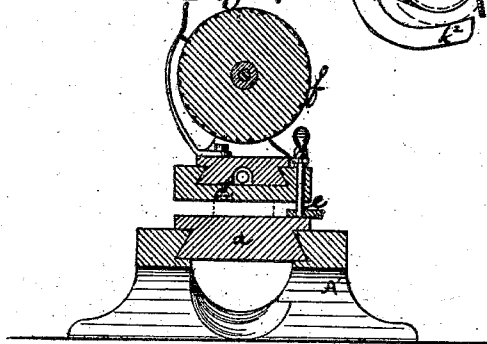

Fig 5.



Witnesses.

S. J. Hayes
D. R. Ford

Inventor

H. D. Knight by
H. M. Beader, atty

United States Patent Office.

HORATIO D. KNIGHT, OF ELGIN, ILLINOIS.

Letters Patent No. 109,325, dated November 15. 1870.

IMPROVEMENT IN MACHINES FOR GRINDING AND POLISHING LENSES. &c.

The Schedule referred to in these Letters Patent and making part of the same.

To all whom it may concern :

Be it known that I, HORATIO D. KNIGHT, of Elgin, in the county of Kane and State of Illinois, have invented a new and useful Improvement in Grinding-Machines; and I do hereby declare that the following is a full and exact description of the same, reference being had to the accompanying drawing and to the letters of reference marked thereon.

This invention relates to machines for grinding microscopic lenses or faceted or plain conic sections for jewelry, and for like purposes, and consists of parts hereinafter more particularly set forth.

In the drawing which accompanies and makes part of this specification, I have represented a convenient and practicable form of my machine, of which—

Figure 1 shows a view of a vertical section through the head-stock on the swing-center, the left-hand part carrying the lap being in elevation;

Figure 2, a plan view with the swing-center removed, showing the index on the slide in bed, and the slotted lever with its cam and movable fulcrum;

Figure 3, a perspective view of the swing-center, (detached,) with its head-stock, index-wheel, and spring-stop;

Figure 4, a bottom view of the slotted lever, cam, and bands; and

Figure 5, a section of the slide-carrying mandrel and index-wheel, showing the spring-stop.

The bed or foundation of my machine, which may be of any suitable form or size, is represented in the drawing at A A' A².

A, on the left, carries a slide head-stock, which is moved forward or backward by a screw suitably arranged beneath. This head-stock supports in bearings the mandrel, which carries the lap *a'*, and has a pulley, *a²*, of proper size and shape fixed upon it.

The bed A¹, on the right, is properly recessed to receive a slide-bed, *a*; the forward end of which is provided with an open socket or sleeve, *b*.

Through this socket passes a closely fitted and strong pivot, *c*, which carries the swinging bed *d*. This swings in horizontal plane.

It is held at any given angle by a segmental index, *d'*, on the sliding bed, a small bolt, *e*, fig. 5, being pressed down by the spring on the lever *e'*, to which it is attached, and passing into holes in the said index.

Upon this swinging bed is another slide head-stock, E, fig. 3, carrying a mandrel and fed forward in the same manner as that before described, for the purpose of moving the point of the chuck on the end of the mandrel beyond the swing-center, thereby elongating or shortening the radius, and giving different arcs of curvature. This mandrel is revolved in suitable bearings by a pulley fixed thereon, and has suitable chucks for holding the lens or stone to be ground.

It has also an index-wheel, *f*, the periphery of which

is indented with holes adapted to receive a stop on a spring-arm, *f'*, as is clearly shown in fig. 5 of the drawing. It will be seen that this mandrel may be revolved by the pulley fixed upon it, or may be locked by the index-wheel and its appropriate stop. By means of the screw the head-stock may be advanced any suitable distance, carrying the chuck beyond the swing-center as far as desired, thereby changing the radius of the object to be ground.

The socketed slide-bed *a* has been shown as fitted to slide in the fixed bed A¹, fig. 5, carrying the mandrel in direct lines to and from the lap. This slide is moved by the swinging of the socketed bed, by the mechanism shown chiefly in fig. 4.

The pivot of the swinging bed passes quite through the socket, and is provided below with a pulley, *g*.

This pulley is connected by steel bands to another pulley, *g'*, which is fixed on a short vertically-arranged pivot, *h*, in the outer extremity of the foundation A². The bands are crossed, to give reverse motion to the outer pulley.

On the upper end of the pivot *h* is a cam, *i*, of any desired shape, to give suitable motion to the lever *k*.

This lever has arms, *k¹ k²*, inclosing the cam, and, at the other end, a ring, inclosing the socket of the sliding-bed.

The lever is slotted along its central part to admit of a movable fulcrum, *l*, which is held at any desired point by the thumb-screw.

The fulcrum is moved by means of the screw *m*. It will be seen that when the swinging bed moves upon its pivot, the outer pulley, *g'*, is revolved through the steel band, thus turning the cam on the upper end of pivot. This cam is of such shape as to give any desired motion to the lever, through which the head-stock is caused to advance or recede relatively to the swing-center. This motion, it is evident, may be increased by moving the fulcrum outward, or diminished by the reverse motion. The cam may be detachably fixed to the vertical pivot, and any desired shape of cam placed thereon, corresponding to the requirements of the figure to be ground. The chuck may also be changed for the purpose of holding lenses, or whatever other object may be presented for grinding.

When grinding facets, the index-wheel on the mandrel is locked by the spring-catch, the holes allowing the mandrel to be turned and fixed in any position.

Having thus fully described my invention, so that any one skilled in the art to which it appertains may be able to make and use the same,

What I claim as new, and desire to secure by Letters Patent of the United States, is—

1. In a machine for grinding curved or faceted surfaces, a swing-center, *c*, in combination with a sliding head-stock, E, mandrel, and revolving lap, as set forth.

2. The swinging bed *d*, carrying the sliding head-

stock E and mandrel, when the parts are so arranged that the point of the chuck may be advanced beyond the swing-center, for the purpose set forth.

3. The swinging bed *d*, carrying the mandrel, when the said bed is moved forward and backward by the swinging motion, as set forth.

4. The socketed slide-bed *a*, carrying the swinging bed, with its pinion, the said pinion being connected to a cam for moving the sliding bed through a lever.

5. The steel bands, connecting the pulleys *g g*, arranged as described, the outer carrying a cam of any desired form, the cam operating on the lever, as set forth.

6. In combination with the lever *k*, a movable fulcrum, as set forth.

7. The slotted lever *k*, constructed as shown, and held by the movable fulcrum, as shown and described.

8. In combination with the sliding bed and swinging bed, the index *f*, as set forth.

9. The index-wheel *f* and pawl, in combination with the mandrel, as described.

10. The slide head-stock, carrying the lap *a*, in combination with the swinging and lever-moved sliding bed, all as set forth.

This specification signed and witnessed this 20th day of August, 1870.

H. D. KNIGHT.

Witnesses:

C. M. DANIELS,
GEORGE E. CHILDS.