



- (51) **International Patent Classification:**
A46B 9/04 (2006.01)
- (21) **International Application Number:**
PCT/US2014/070424
- (22) **International Filing Date:**
16 December 2014 (16.12.2014)
- (25) **Filing Language:** English
- (26) **Publication Language:** English
- (30) **Priority Data:**
14/135,598 20 December 2013 (20.12.2013) US
- (71) **Applicant:** HANKOOKIN, INC. [US/US]; 9104 Glenwood Ave., Raleigh, NC 27617 (US).
- (72) **Inventor; and**
(71) **Applicant :** CHUN, James, Jiwen [US/US]; 5212 Richland Dr., Raleigh, NC 27612 (US).
- (72) **Inventors:** CHUN, Andrew, Youngho; 5212 Richland Dr., Raleigh, NC 27612 (US). CHUN, Angela, Soyoung; 5212 Richland Dr., Raleigh, NC 27612 (US). CHUN, Jennifer, Miseong; 5212 Richland Dr., Raleigh, NC 27612 (US).
- (74) **Agent:** TANKHA, Ashok; 36 Greenleigh Drive, Sewell, NJ 08080 (US).

- (81) **Designated States** (unless otherwise indicated, for every kind of national protection available): AE, AG, AL, AM, AO, AT, AU, AZ, BA, BB, BG, BH, BN, BR, BW, BY, BZ, CA, CH, CL, CN, CO, CR, CU, CZ, DE, DK, DM, DO, DZ, EC, EE, EG, ES, FI, GB, GD, GE, GH, GM, GT, HN, HR, HU, ID, IL, IN, IR, IS, JP, KE, KG, KN, KP, KR, KZ, LA, LC, LK, LR, LS, LU, LY, MA, MD, ME, MG, MK, MN, MW, MX, MY, MZ, NA, NG, NI, NO, NZ, OM, PA, PE, PG, PH, PL, PT, QA, RO, RS, RU, RW, SA, SC, SD, SE, SG, SK, SL, SM, ST, SV, SY, TH, TJ, TM, TN, TR, TT, TZ, UA, UG, US, UZ, VC, VN, ZA, ZM, ZW.
- (84) **Designated States** (unless otherwise indicated, for every kind of regional protection available): ARIPO (BW, GH, GM, KE, LR, LS, MW, MZ, NA, RW, SD, SL, ST, SZ, TZ, UG, ZM, ZW), Eurasian (AM, AZ, BY, KG, KZ, RU, TJ, TM), European (AL, AT, BE, BG, CH, CY, CZ, DE, DK, EE, ES, FI, FR, GB, GR, HR, HU, IE, IS, IT, LT, LU, LV, MC, MK, MT, NL, NO, PL, PT, RO, RS, SE, SI, SK, SM, TR), OAPI (BF, BJ, CF, CG, CI, CM, GA, GN, GQ, GW, KM, ML, MR, NE, SN, TD, TG).

Declarations under Rule 4.17:

— of inventorship (Rule 4.17(iv))

Published:

— with international search report (Art. 21(3))

(54) **Title:** TOOTHBRUSH APPARATUS WITH AN ARCUATE TOOTHBRUSH HEAD AND BRISTLE CONFIGURATION

(57) **Abstract:** A toothbrush apparatus includes a handle with a longitudinal axis and a toothbrush head constructed and arranged to hold multiple bristles. The bristles are formed in a non-circular configuration. The non-circular configuration is on a distal end, or a portion including the distal end, or the entire bristle. A wall defining an elongated bristle body of each bristle tapers from a base end towards a chisel end of the elongated bristle body. The toothbrush head is of an arcuate shape that conforms to a dental arch. The toothbrush apparatus includes one or more bristle carriers for detachably attaching multiple bristles to the toothbrush head. The second end of each of the bristles of predetermined heights defines a first curved trim profile and a perpendicular second curved trim profile. The bristles in the first curved trim profile at a terminal end of the toothbrush head are extended to reach rear teeth.



TOOTHBRUSH APPARATUS WITH AN ARCUATE TOOTHBRUSH HEAD AND BRISTLE CONFIGURATION

CROSS REFERENCE TO RELATED APPLICATIONS

[0001] This application is a PCT application of patent application number 14/135,598 titled "Toothbrush Apparatus With An Arcuate Toothbrush Head And Bristle Configuration", filed in the United States Patent and Trademark Office on 20 December 2013, which is a continuation-in-part application of non-provisional patent application number 13/027,330 titled "Toothbrush With Bristles Of Non Circular Tips", filed in the United States Patent and Trademark Office on 15 February 2011 and now issued as US Patent No. 8,635,734. The specifications of the above referenced patent applications are incorporated herein by reference in their entirety.

BACKGROUND

[0002] Dental health and hygiene is an area that is still evolving and undergoing many improvements. The toothbrush has seen numerous improvements and advancements in recent years. For cleaning teeth, the tooth brushing technique recommended by the American Dental Association (ADA) and most dentists is to tilt the toothbrush, for example, at about a 45° angle against the gum line and with gentle force, brush forward and backward with a short vibratory movement, and sweep or roll the toothbrush away from the gum line. More force should be applied in the rolling or sweeping movements to remove plaque and debris between the teeth. The efficacy of tooth brushing remains an unpublicized but pressing issue.

[0003] In fact, most people brush with a circling motion. According to a research article by C. Ganss, N. Schlueter, S. Preiss, and J. Klimek (Clinical Oral Investigations, Volume 13, Number 2,203-208,2008), the mean brushing force was, for example, about 2.3 ± 0.7 Newton (N) with a maximum force of about 4.1 N. Most subjects, for example, about 73.8%, brushed with a circling motion, about 8.7% brushed with horizontal/ scrubbing

movements, about 13.6% brushed with horizontal/circling movements, and about 3.9% brushed with vertical sweeping movements. Many electric toothbrushes such as Oral-B[®] of Procter & Gamble Business Services Canada Company Corporation also use a circular brushing motion. Thus, there is a discrepancy between the ADA recommendation and the common brushing techniques.

[0004] Vigorous tooth brushing can cause gum and root recession, tooth sensitivity, and tooth abrasion such as wedge shape defects and dental erosion. Even though most dentists recommend using toothbrushes with soft or medium bristles, tooth abrasion is still very common among people with over vigorous oral hygiene habits. Horizontal defects are mostly due to the brushing force in a forward direction and a backward direction across the teeth surface, and this is the reason for the emphasis placed by the ADA on the sweeping or rolling motion for brushing the plaque and debris away from the gum line.

[0005] In addition to the angle of brushing and the brushing force, the shape of a toothbrush head and the configuration of the bristles also affect proper brushing of different portions of the teeth. For example, a rear portion of the third molar tooth is typically not properly brushed owing to the shape and location of the third molar tooth. Conventional toothbrushes generally have straight toothbrush heads with bristles of a uniform height having flat bristle ends. The flat bristle ends fail to conform to the surface curvature of teeth and fail to reach certain portions of the teeth structure, for example, the rear end of the third molar tooth. A toothbrush with a toothbrush head that conforms to a dental arch, and that has a bristle configuration that can reach any section around the teeth structure to facilitate complete and efficient brushing is not available in the market.

[0006] Hence, there is a long felt but unresolved need for a toothbrush apparatus with an arcuate toothbrush head and bristle configuration that conforms to a dental arch and to the surface curvature of teeth and that can reach any portion around the teeth structure to facilitate complete and efficient brushing.

SUMMARY OF THE INVENTION

[0007] This summary is provided to introduce a selection of concepts in a simplified form that are further disclosed in the detailed description of the invention. This summary is not intended to identify key or essential inventive concepts of the claimed subject matter, nor is it intended for determining the scope of the claimed subject matter.

[0008] The toothbrush apparatus disclosed herein addresses the above mentioned deficiencies by providing a geometric configuration to the shape of a toothbrush bristle to reduce a brushing force in a horizontal forward and backward direction, with an emphasis on a sweeping or rolling force during brushing. Instead of using a commonly used bristle with a round cross section, bristles with an oval cross section are provided and a major axis of the oval cross section of each of the bristles is aligned perpendicular to a longitudinal axis of the brush handle. The toothbrush apparatus disclosed herein also has an arcuate toothbrush head and bristle configuration that conforms to a dental arch and to the surface curvature of teeth and that can reach any portion around the teeth structure to facilitate complete and efficient brushing. As used herein, the phrase “dental arch” refers to a curved orientation of teeth on an upper jaw and a lower jaw of a mouth.

[0009] The toothbrush apparatus disclosed herein comprises a handle, a toothbrush head, and multiple bristles. The handle has a longitudinal axis. The toothbrush head is constructed and arranged to hold the bristles. The bristles are formed in a non-circular configuration as viewed from a first end, that is, a proximal end that is attached to the toothbrush head, from a second end, where the second end is a distal end that is not connected to the toothbrush head and is configured to contact the teeth during brushing, or in a cross section from some area along the length of the bristle. In an embodiment, the bristles are circular for some portion of the bristle body and the distal end or the second end has the non-circular configuration.

[0010] In an embodiment, the non-circular configuration of the bristles is an elliptical configuration as viewed from any of the first end, the second end, or along the cross section of the bristles. If the bristles are circular with a non-circular configuration at the

distal end, the non-circular configuration is viewed from the second end or in the cross section near the distal end. The elliptical configuration of the bristles is defined by a geometric eccentricity greater than 0. The elliptical configuration has a major axis perpendicular to the longitudinal axis. In an embodiment, the toothbrush apparatus disclosed herein further comprises a circular socket with bristles placed thereon. In an embodiment, the bristles are inserted into a non-circular socket.

[0011] The toothbrush bristle of the toothbrush apparatus disclosed herein comprises a continuous elongated bristle body and a continuous wall defining the continuous elongated bristle body. The bristle has a cylindrical non-circular distal end. The non-circular portion may be on the distal end of the bristle, a portion including the end of the bristle, or may extend along the entire length of the bristle. The non-circular portion extends for less than the entire length of the bristle, and the remaining portion is circular. In an embodiment, the non-circular portion extends, for example, from about 1% to about 20% of the entire length of the bristle. As disclosed herein, the term “non-circular” includes elliptical and oval configurations.

[0012] Disclosed herein is a bristle comprising an elongated bristle body and a wall. The elongated bristle body has a first end herein also referred to as a “base end”, and a second end herein also referred to as a “distal end” that opposes the base end. The wall defines the elongated bristle body. The wall continuously tapers from the first end towards the second end. In an embodiment, the cross section of the elongated bristle body at the first end is greater than the cross section of the elongated bristle body at the second end. In an embodiment, the second end of the elongated bristle body defines a plane surface, where the plane surface is perpendicular to a line extending along a length of the elongated bristle body. In another embodiment, the plane surface of the second end is inclined with respect to a line extending along the length of the elongated bristle body. In an embodiment, the first end of the elongated bristle body is adapted to be attached to the toothbrush head of the toothbrush apparatus disclosed herein.

[0013] Disclosed herein is a toothbrush apparatus comprising a generally arcuate toothbrush head, one or more bristle carriers, and multiple bristles. The arcuate toothbrush head conforms to a dental arch. The arcuate toothbrush head is of a curvedly tapering thickness towards the terminal end of the arcuate toothbrush head along the longitudinal axis of the toothbrush apparatus. The arcuate toothbrush head comprises one or more base sections on an upper surface of the arcuate toothbrush head. One or more bristle carriers are detachably attached to one or more base sections on the upper surface of the arcuate toothbrush head. Multiple bristles of predetermined heights are attached to each of the bristle carriers. Each bristle has a first end and an opposing second end. The first end of each bristle is attached to a bristle carrier. The second end of each of the bristles of predetermined heights is configured to define a first curved trim profile along a longitudinal axis of the toothbrush apparatus, and a second curved trim profile substantially perpendicular to the longitudinal axis of the toothbrush apparatus. As used herein, the phrase “curved trim profile” refers to a curved profile defined by trimming distal ends of a cluster of bristles. The bristles in the first curved trim profile, positioned proximal to a terminal end of the arcuate toothbrush head, are configured to extend to reach a rear section of rear teeth along the dental arch.

[0014] In an embodiment, the bristles in the first curved trim profile positioned proximal to an opposing end of the terminal end of the arcuate toothbrush head are of heights lower than heights of the bristles positioned proximal to the terminal end of the arcuate toothbrush head. The bristles in the first curved trim profile positioned proximal to the opposing end of the terminal end of the arcuate toothbrush head are configured to reach a frontal section of the rear teeth and frontal teeth. The second curved trim profile which is substantially perpendicular to the longitudinal axis of the toothbrush apparatus conforms to a surface curvature of the teeth.

BRIEF DESCRIPTION OF THE DRAWINGS

[0015] The foregoing summary, as well as the following detailed description of the invention, is better understood when read in conjunction with the appended drawings. For

the purpose of illustrating the invention, exemplary constructions of the invention are shown in the drawings. However, the invention is not limited to the specific structures disclosed herein. The description of a structure referenced by a numeral in a drawing carries over to the description of that structure shown by that same numeral in any subsequent drawing herein.

[0016] FIG. 1 exemplarily illustrates a plan view of an embodiment of a toothbrush apparatus, where bristles are arranged in elliptical bundles along a longitudinal axis XX.

[0017] FIG. 2 exemplarily illustrates a plan view of an embodiment of the toothbrush apparatus, where bristles are arranged in oval bundles along a longitudinal axis XX.

[0018] FIG. 3 exemplarily illustrates a side view of a toothbrush head of the toothbrush apparatus, showing a curved profile of bristles of predetermined heights.

[0019] FIG. 4 exemplarily illustrates a side view of the toothbrush head of the toothbrush apparatus, showing a horizontal profile of bristles of uniform heights.

[0020] FIG. 5 exemplarily illustrates a top view of a single oval bristle.

[0021] FIG. 6 exemplarily illustrates a top view of a single elliptical bristle.

[0022] FIG. 7A exemplarily illustrates a partial side view of a single bristle with a chisel end.

[0023] FIG. 7B exemplarily illustrates a partial side view of a single bristle with a straight horizontal end.

[0024] FIG. 8 exemplarily illustrates a partial side view of a single bristle with a chisel end.

[0025] FIG. 9 exemplarily illustrates a partial side view of a single bristle with a round tip.

[0026] FIG. 10 exemplarily illustrates a partial side view of a single bristle with a tapered tip.

[0027] FIG. 11 exemplarily illustrates a plan view of the toothbrush head of the toothbrush apparatus having elliptical bristles arranged perpendicular to a longitudinal axis XX.

[0028] FIG. 12 exemplarily illustrates an expanded view showing arrangements of individual elliptical bristles of the toothbrush apparatus in a circular bundle.

[0029] FIG. 13 exemplarily illustrates a top view of a single elliptical bristle.

[0030] FIG. 14A exemplarily illustrates a top perspective view of an embodiment of the toothbrush apparatus with an arcuate toothbrush head.

[0031] FIG. 14B exemplarily illustrates an enlarged view of a portion A of the embodiment of the toothbrush apparatus shown in FIG. 14A.

[0032] FIG. 15 exemplarily illustrates a partial exploded view of the embodiment of the toothbrush apparatus shown in FIG. 14A.

[0033] FIG. 16A exemplarily illustrates a side elevation view of the embodiment of the toothbrush apparatus shown in FIG. 14A.

[0034] FIG. 16B exemplarily illustrates a front elevation view of the embodiment of the toothbrush apparatus shown in FIG. 14A.

[0035] FIG. 17A exemplarily illustrates an application of the embodiment of the toothbrush apparatus shown in FIG. 14A on a rear section of rear teeth.

[0036] FIG. 17B exemplarily illustrates an application of the embodiment of the toothbrush apparatus shown in FIG. 14A on a frontal section of rear teeth.

DETAILED DESCRIPTION OF THE INVENTION

[0037] The toothbrush bristles of the toothbrush apparatus **100** exemplarily illustrated in FIG. 1 relates to a geometric configuration of individual bristle fibers. While all bristles conventionally utilized are cylindrical, for example, having a circular cross section, the toothbrush apparatus **100** disclosed herein provides for curved cylindrical bristles **12** and **16** having a non-circular configuration as exemplarily illustrated in FIGS. 1-2. As used herein, the phrase “curved cylinder” describes the geometric configuration of curved cylindrical bristles **12** and **16** that do not have a circular cross section. The curved cylinder geometric configuration includes all elliptical and oval configurations. The toothbrush apparatus **100** disclosed herein includes toothbrush bristles, for example, **12** and **16** formed of materials known in the art and relates is particular to the geometric configuration and not the material composition.

[0038] As exemplarily illustrated in FIG. 5, an oval bristle **16** with an oval configuration has opposing, substantially parallel sides **22** and opposing radial ends **24**, and as exemplarily illustrated in FIG. 6, an elliptical bristle **12** with an elliptical configuration has a continuous, non-circular curvature. FIG. 13 exemplarily illustrates a top view of a single elliptical bristle **12**. As known in the art and as exemplarily illustrated in FIG. 13, an elliptically configured bristle **12** has a semi-major axis YY and a semi-minor axis XX.

[0039] An ellipse has a first focus point and a second focus point, collectively referred to as “foci”, along the semi-major axis YY. The foci of the ellipse are equidistant from the center point. The eccentricity of an ellipse is the ratio of the distance between the two

foci to the length of the major axis. For an ellipse, the eccentricity is between 0 and 1. When the eccentricity is 0, the foci coincide with the center point and the figure is a circle. As the eccentricity tends towards 1, the ellipse gets a more elongated shape. The ellipse tends towards a line segment. For the toothbrush apparatus **100** disclosed herein, the elliptical bristles **12** that have an elliptical configuration have an eccentricity greater than zero to exclude circular configurations. The degree of elongation can be varied in the toothbrush apparatus **100** disclosed herein.

[0040] The toothbrush apparatus **100** disclosed herein has several embodiments, all with non-circular bristles that are functional to varying degrees.

[0041] FIG. **1** exemplarily illustrates a plan view of an embodiment of the toothbrush apparatus **100**, where bristles **12** are arranged in elliptical bundles **101** along a longitudinal axis XX. The plan view exemplarily illustrated in FIG. **1** is simplified for demonstrative purposes. The XX axis of FIG. **1** represents the longitudinal axis of the toothbrush apparatus **100** which would also include a toothbrush handle **14** (only connective portion shown) that is integral with a toothbrush head **10**. Each of the elliptical bristles **12** has a semi-major axis parallel to the longitudinal axis XX of FIG. **1**. For demonstrative purposes only, FIG. **1** depicts the general orientation of individual elliptical bristles **12**.

[0042] FIG. **2** exemplarily illustrates a plan view of an embodiment of the toothbrush apparatus **100**, where bristles **16** are arranged in oval bundles **102** along a longitudinal axis XX. The plan view exemplarily illustrated in FIG. **2** is simplified for demonstrative purposes. The XX axis of FIG. **2** represents the longitudinal axis of the toothbrush apparatus **100** which would also include a toothbrush handle **14** (only connective portion shown) that is integral with the toothbrush head **10**. Each of the oval bristles **16** has a longitudinal axis parallel to longitudinal axis XX of FIG. **2**. For demonstrative purposes only, FIG. **2** depicts the general orientation of individual oval bristles **16**.

[0043] FIGS. 3-4 exemplarily illustrate side views of the toothbrush head **10** of the toothbrush apparatus **100** exemplarily illustrated in FIG. 1. FIG. 3 shows a curved profile **18** of bristles **103** of predetermined heights. FIG. 4 shows a horizontal profile **20** of bristles **103** of uniform heights. FIG. 3 and FIG. 4 demonstrate that the bristle arrangements **18** and **20** of the toothbrush apparatus **100** include bristle ends that form a curved profile **18** along a curved line ZZ and bristle ends that form a horizontal profile **20** along a straight line WW respectively.

[0044] FIGS. 7A-7B exemplarily illustrate partial side views of a single bristle **103**. FIG. 7A shows a single bristle **103** on the toothbrush head **10** in which the single bristle **103** which has a second end **28a** configured as a chisel end moves with an angular offset **26** based on height **34** of the single bristle **103**. The angular offset **26** can be varied as desired in order to improve efficiency of brushing without undue application of force. The bristle **103** disclosed herein comprises an elongated bristle body **104** and a wall **105**. The elongated bristle body **104** has a first end also referred to as a base end **28b**, and a second end **28a** or **28c** opposing the base end **28b**. The wall **105** defines the elongated bristle body **104**. The wall **105** continuously tapers from the base end **28b** towards the second end **28a** or **28c**. The base end **28b** of the elongated bristle body **104** is adapted to be attached to the toothbrush head **10**. In an embodiment, the cross section of the elongated bristle body **104** at the base end **28b** is greater than the cross section of the elongated bristle body **104** at the second end **28a** or **28c**. In an embodiment, the second end **28c** of the elongated bristle body **104** defines a plane surface **106**, where the plane surface **106** is perpendicular to a line **107** extending along the length **34** of the elongated bristle body **104** as exemplarily illustrated in FIG. 7B. FIG. 7B shows a single bristle **103** with a straight horizontal second end **28c**. In another embodiment, the plane surface **106** of the second end **28a** is inclined with respect to a line **107** extending along the length **34** of the elongated bristle body **104** as exemplarily illustrated in FIG. 7A.

[0045] FIG. 8, FIG. 9, and FIG. 10 exemplarily illustrate partial side views of a single bristle **103** with a chisel end **28a**, a round tip **30**, and a tapered tip **32** respectively. FIGS. 8-10 show that the toothbrush apparatus **100** is operable with varying end configurations

comprising, for example, a chisel end **28a** as shown in FIG. **8**, a round tip **30** as shown in FIG. **9**, and a tapered tip **32** as shown in FIG. **10**.

[0046] FIG. **11** exemplarily illustrates a plan view of the toothbrush head **10** of the toothbrush apparatus **100** having elliptical bristles **12** arranged perpendicular to a longitudinal axis **XX**. FIG. **11** depicts a demonstrative embodiment of the toothbrush apparatus **100**, showing the orientation of individual elliptical bristles **12** oriented with a semi-major axis **YY** that is perpendicular to the longitudinal axis **XX** of the toothbrush head **10**.

[0047] FIG. **12** exemplarily illustrates an expanded view showing arrangements of individual elliptical bristles **12** of the toothbrush apparatus **100** in a circular bundle **108**. FIG. **12** shows a single circular bundle **108** of elliptical bristles **12** in a circular bristle socket. The individual bristles **12** are elliptical, but the bundle **108** is circular. In this embodiment, the semi-major axis **YY** of each of the elliptical bristles **12** is perpendicular to the longitudinal axis **XX** of the toothbrush head **10**.

[0048] The toothbrush apparatus **100** disclosed herein overcomes a deficiency in the art, namely, current circular bristles result in damage to the teeth when an over application of force is applied by the user. Utilization of non-circular bristles disclosed herein provides a different distribution of force and allows teeth to be effectively brushed with reduced pressure and force on tooth surfaces.

[0049] In an embodiment, the bristle fiber disclosed herein with a non-circular cross section can be used in combination with bristle fibers having round cross sections, where non-circular type of bristles, for example, **12** and **16** exemplarily illustrated in FIGS. **1-2**, are used in a part of the region of the toothbrush area, while in other regions, round cross section bristles are used. That is, the distal end of the bristle is non-circular and the remaining section of the bristle is circular. As used herein, the phrase “remaining section” refers to any remaining portion that is not at or near the distal end.

[0050] FIG. 14A exemplarily illustrates a top perspective view of an embodiment of the toothbrush apparatus 100 with an arcuate toothbrush head 109. FIG. 14B exemplarily illustrates an enlarged view of a portion A of the embodiment of the toothbrush apparatus 100 shown in FIG. 14A. The toothbrush apparatus 100 disclosed herein comprises a toothbrush handle 14, a generally arcuate toothbrush head 109 configured at a distal end 14a of the toothbrush handle 14, and bristles 103 fixedly attached on an upper surface 109a of the arcuate toothbrush head 109. The bristles 103 form a first curved trim profile 111 represented by a curved line MM along a longitudinal axis OO of the toothbrush apparatus 100, and a second curved trim profile 110 represented by a curved line NN along the longitudinal axis OO of the toothbrush apparatus 100 as disclosed in the detailed description of FIG. 15. As used herein, the phrase “curved trim profile” refers to a curved profile defined by trimming distal ends of a cluster of bristles 103. In an embodiment, for orthodontic patients, the bristles 103 can be trimmed to accommodate the shape of brackets on a tooth surface.

[0051] FIG. 15 exemplarily illustrates a partial exploded view of the embodiment of the toothbrush apparatus 100 shown in FIG. 14A. In this embodiment, the toothbrush apparatus 100 disclosed herein comprises a generally arcuate toothbrush head 109, one or more bristle carriers 112, and multiple bristles 103. The arcuate toothbrush head 109 conforms to a dental arch 114 as exemplarily illustrated in FIGS. 17A-17B. As used herein, the phrase “dental arch” refers to a curved orientation of teeth on an upper jaw and a lower jaw of a mouth. The arcuate toothbrush head 109 comprises one or more base sections 113 on an upper surface 109a of the arcuate toothbrush head 109. The bristle carriers 112 are detachably attached to the base sections 113 on the upper surface 109a of the arcuate toothbrush head 109. The bristles 103 of predetermined heights are attached to each of the bristle carriers 112. The bristles 103 can be inserted into the bristle carriers 112, and then these bristle carriers 112 can be inserted into the base sections 113 on the upper surface 109a of the arcuate toothbrush head 109 as individual blocks. In the manufacturing process of the toothbrush apparatus 100, the attachment or insertion of the bristles 103 on the bristle carriers 112 avoids the bristle insertion process on the arcuate toothbrush head 109, thereby providing a flexible method of bristle insertion. Each bristle

103 has a first end **103a** and an opposing second end **103b**. The first end **103a** of each bristle **103** is attached to the bristle carriers **112**. The second end **103b** of each of the bristles **103** of predetermined heights defines a first curved trim profile **111** along a longitudinal axis OO of the toothbrush apparatus **100** as exemplarily illustrated in FIG. **16A**, and a second curved trim profile **110** substantially perpendicular to the longitudinal axis OO of the toothbrush apparatus **100** as exemplarily illustrated in FIG. **16B**. In an embodiment, the base sections **113** are provided on the lower surface **109b** of the arcuate toothbrush head **109** and made of a rubber type material for use as a soft tissue scraper and cleaner.

[0052] FIGS. **16A-16B** exemplarily illustrate a side elevation view and a front elevation view of the embodiment of the toothbrush apparatus **100** shown in FIG. **14A**, respectively. The bristles **103** in the first curved trim profile **111** positioned proximal to an opposing end **109d** of a terminal end **109c** of the arcuate toothbrush head **109** are of heights lower than heights of the bristles **103** positioned proximal to the terminal end **109c** of the generally arcuate toothbrush head **109**. In an embodiment, the arcuate toothbrush head **109** is of a curvedly tapering thickness towards the terminal end **109c** of the arcuate toothbrush head **109** along the longitudinal axis OO of the toothbrush apparatus **100**. The terminal end **109c** of the arcuate toothbrush head **109** is narrow and flexible to enable a user to reach rear teeth **115**, for example, molar teeth as exemplarily illustrated in FIGS. **17A-17B**. The second curved trim profile **110** extends over the terminal end **109c** of the arcuate toothbrush head **109**.

[0053] FIGS. **17A-17B** exemplarily illustrate an application of the embodiment of the toothbrush apparatus **100** shown in FIG. **14A** on a rear section **115a** of rear teeth **115** and on a frontal section **115b** of the rear teeth **115** respectively. The bristles **103** in the first curved trim profile **111** along the curved line MM, positioned proximal to the terminal end **109c** of the arcuate toothbrush head **109**, are configured to extend in a narrow and flexible manner to reach a rear section **115a** of the rear teeth **115** along the dental arch **114**. The longer bristles **103c** are disposed at the terminal end **109c** of the arcuate toothbrush head **109** to reach behind the rear teeth **115**. The bristles **103** in the first

curved trim profile **111** proximal to the opposing end **109d** of the terminal end **109c** of the arcuate toothbrush head **109** are configured to reach the frontal section **115b** of the rear teeth **115**. Shorter bristles **103d** are disposed at the opposing end **109d** of the terminal end **109c** of the arcuate toothbrush head **109** to reach the frontal section **115b** of the rear teeth **115**. As exemplarily illustrated in FIG. **17B**, in an embodiment, the second curved trim profile **110** which is substantially perpendicular to the longitudinal axis OO of the toothbrush apparatus **100** is configured to conform to a surface curvature **116** of teeth.

[0054] The foregoing examples have been provided merely for the purpose of explanation and are in no way to be construed as limiting of the present invention disclosed herein. While the invention has been described with reference to various embodiments, it is understood that the words, which have been used herein, are words of description and illustration, rather than words of limitation. Further, although the invention has been described herein with reference to particular means, materials, and embodiments, the invention is not intended to be limited to the particulars disclosed herein; rather, the invention extends to all functionally equivalent structures, methods and uses, such as are within the scope of the appended claims. Those skilled in the art, having the benefit of the teachings of this specification, may affect numerous modifications thereto and changes may be made without departing from the scope and spirit of the invention in its aspects.

CLAIMS

We claim:

1. A toothbrush apparatus comprising:

a toothbrush head comprising at least one non-circular socket; and

a plurality of bristles, each of said bristles having a first end and a second end, wherein said first end of said each of said bristles is attached to said toothbrush head, wherein at least one of said bristles has an elliptical cross section as viewed from said first end and said second end, and wherein at least one of said bristles is adapted to be accommodated in said at least one non-circular socket of said toothbrush head.

2. The toothbrush apparatus of claim 1, wherein said elliptical cross section is defined by a geometric eccentricity greater than 0.

3. The toothbrush apparatus of claim 1, wherein said toothbrush head further comprises a plurality of circular sockets adapted to accommodate said bristles.

4. A bristle comprising:

an elongated bristle body having a first end and a second end, said second end of said elongated bristle body opposing said first end; and

a wall defining said elongated bristle body, said wall continuously tapering from said first end towards said second end.

5. The bristle of claim 4, wherein a cross section of said elongated bristle body at said first end is greater than a cross section of said elongated bristle body at said second end.
6. The bristle of claim 4, wherein said second end of said elongated bristle body defines a plane surface, wherein said plane surface is perpendicular to a line extending along a length of said elongated bristle body.
7. The bristle of claim 4, wherein said second end of said elongated bristle body defines a plane surface, wherein said plane surface is inclined with respect to a line extending along a length of said elongated bristle body.
8. The bristle of claim 4, wherein said first end of said elongated bristle body is adapted to be attached to a toothbrush head.
9. A toothbrush apparatus comprising:

a generally arcuate toothbrush head, said generally arcuate toothbrush head configured to conform to a dental arch, said generally arcuate toothbrush head comprising one or more base sections on an upper surface of said generally arcuate toothbrush head;

one or more bristle carriers detachably attached to said one or more base sections on said upper surface of said generally arcuate toothbrush head; and

a plurality of bristles of predetermined heights attached to each of said one or more bristle carriers, each of said bristles having a first end and an opposing second end, wherein said first end of said each of said bristles is attached to said one or more bristle carriers, wherein said second end of said each of said bristles of said predetermined heights is configured to define a first curved trim profile along a longitudinal axis of said toothbrush apparatus, and a second curved trim

profile substantially perpendicular to said longitudinal axis of said toothbrush apparatus, wherein said bristles in said first curved trim profile positioned proximal to a terminal end of said generally arcuate toothbrush head are configured to extend to reach a rear section of rear teeth along said dental arch.

10. The toothbrush apparatus of claim 9, wherein said bristles in said first curved trim profile positioned proximal to an opposing end of said terminal end of said generally arcuate toothbrush head are of heights lower than heights of said bristles positioned proximal to said terminal end of said generally arcuate toothbrush head to reach a frontal section of said rear teeth.
11. The toothbrush apparatus of claim 9, wherein said second curved trim profile substantially perpendicular to said longitudinal axis of said toothbrush apparatus is configured to conform to a surface curvature of teeth.
12. The toothbrush apparatus of claim 9, wherein said generally arcuate toothbrush head is of a curvedly tapering thickness towards said terminal end of said generally arcuate toothbrush head along said longitudinal axis of said toothbrush apparatus.

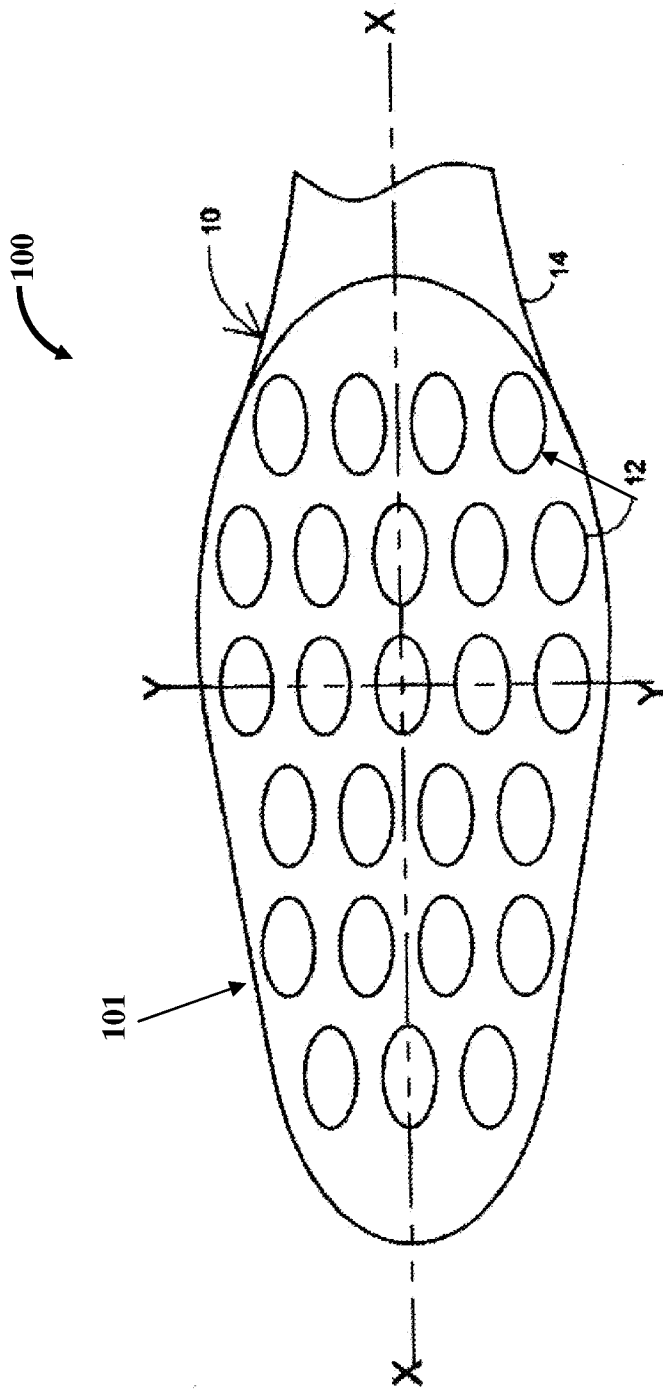

FIG. 1

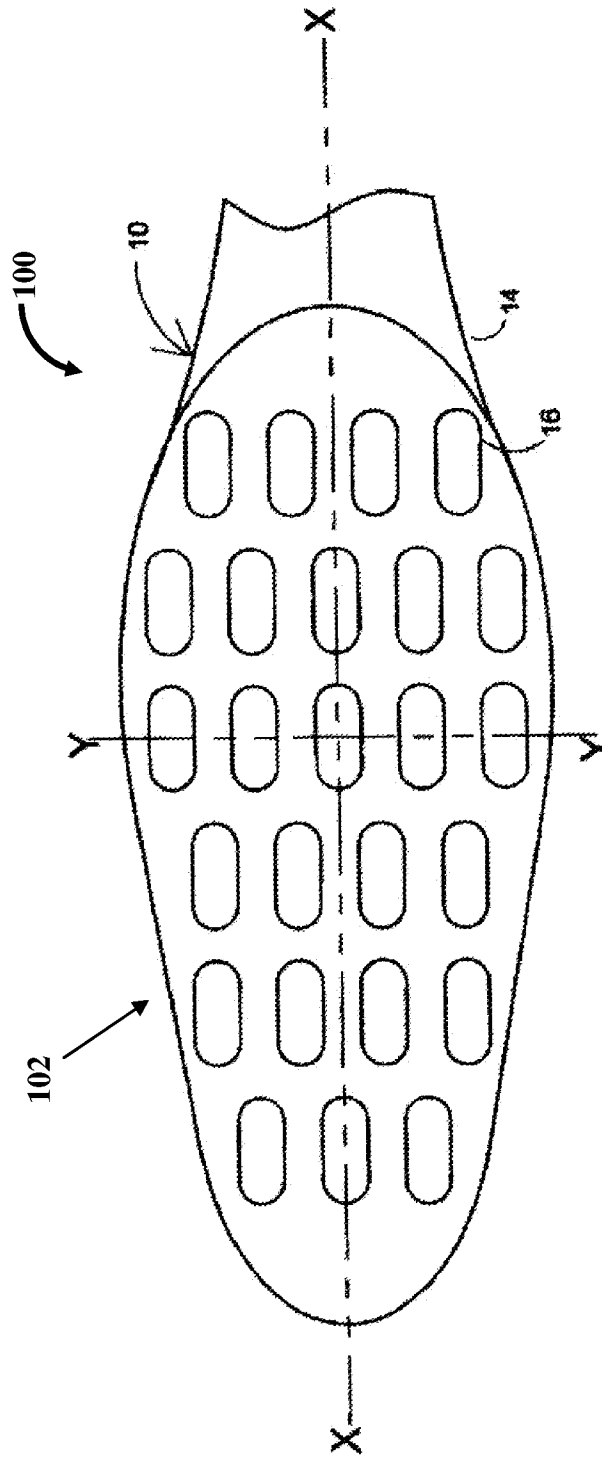

FIG. 2

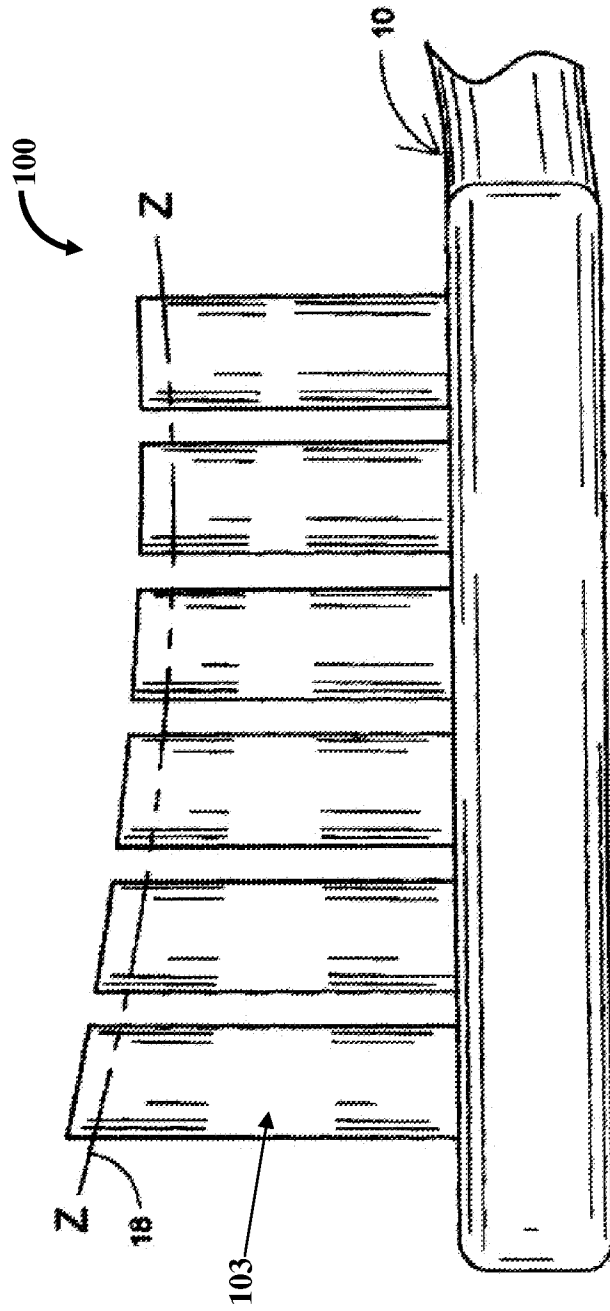

FIG. 3

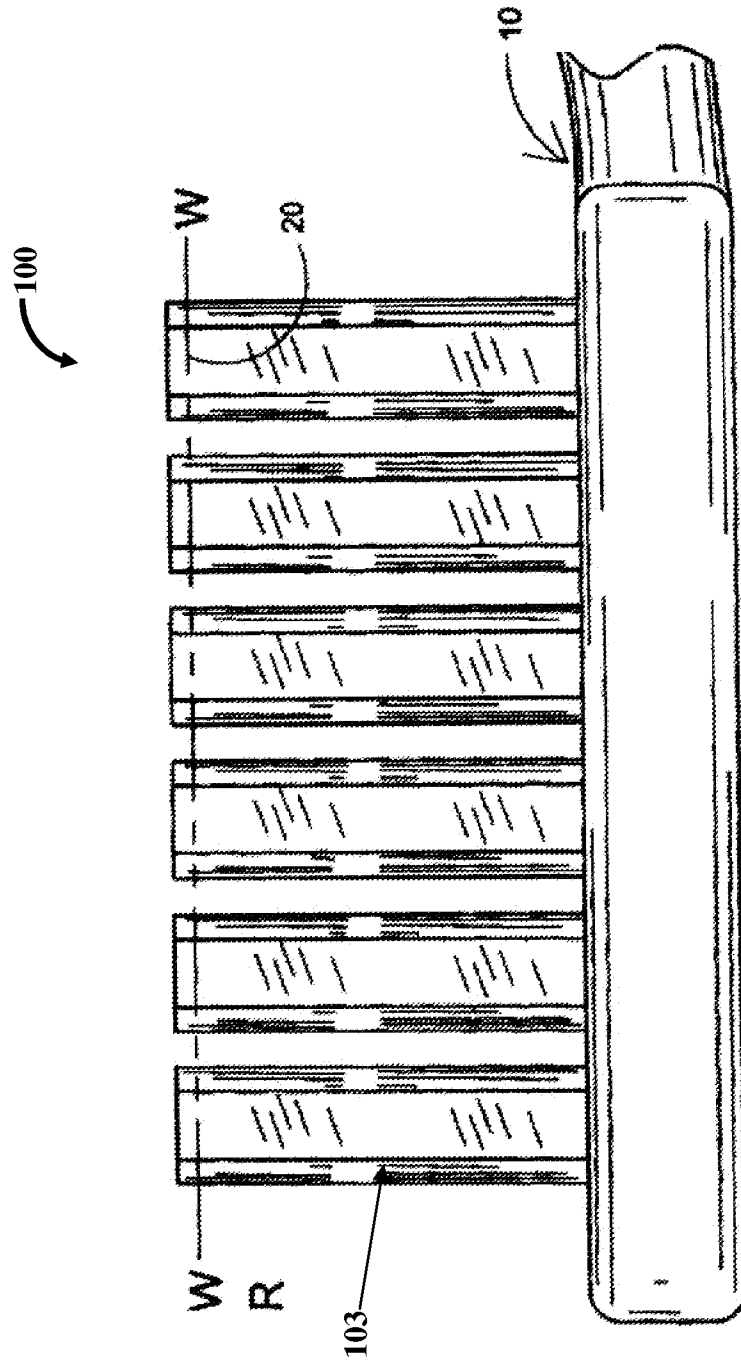

FIG. 4

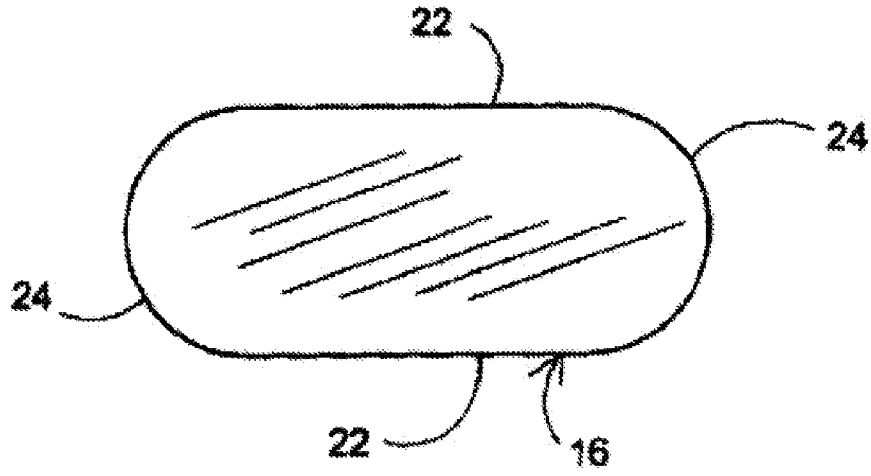

FIG. 5

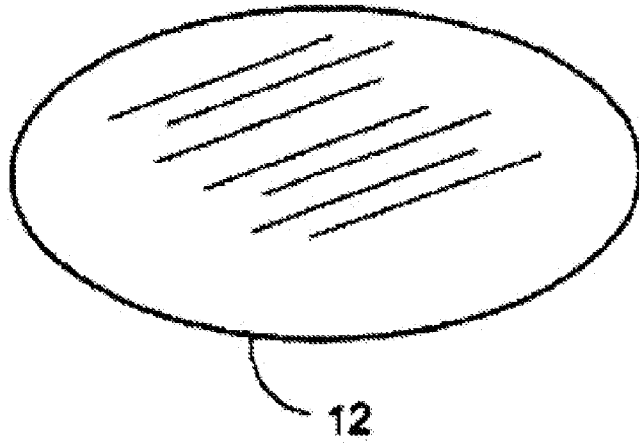

FIG. 6

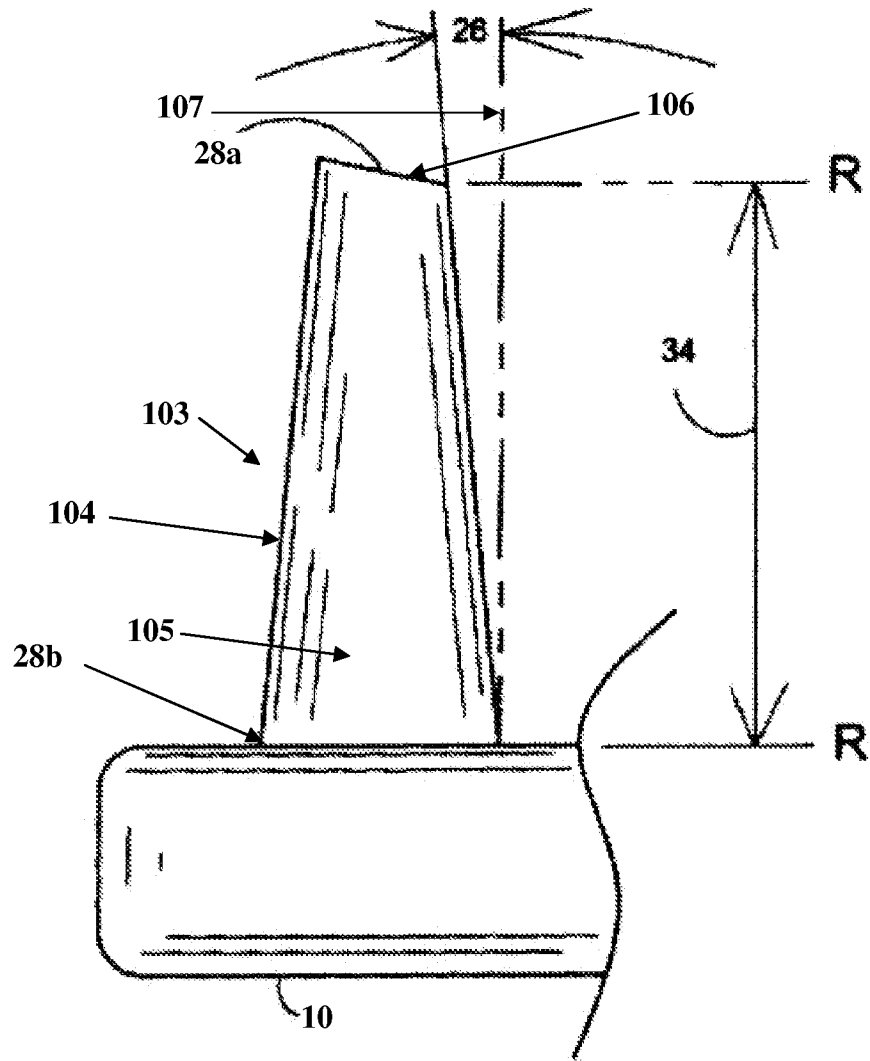

FIG. 7A

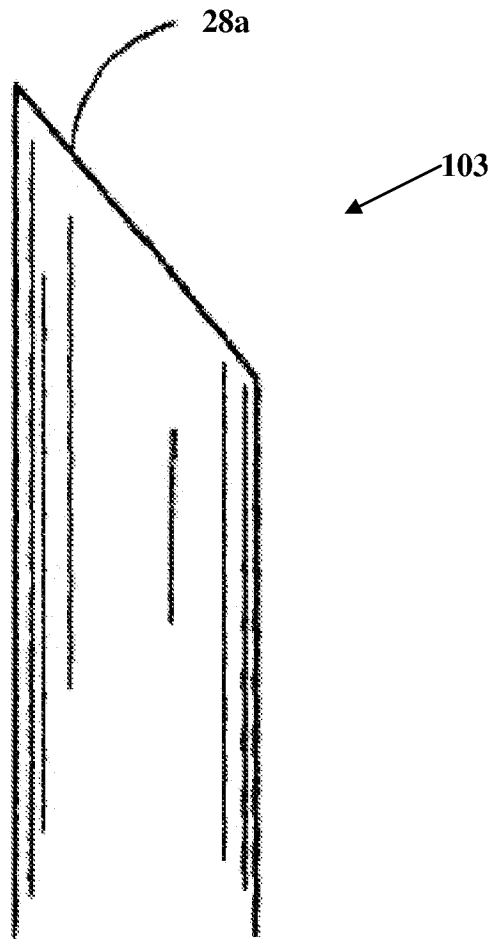

FIG. 8

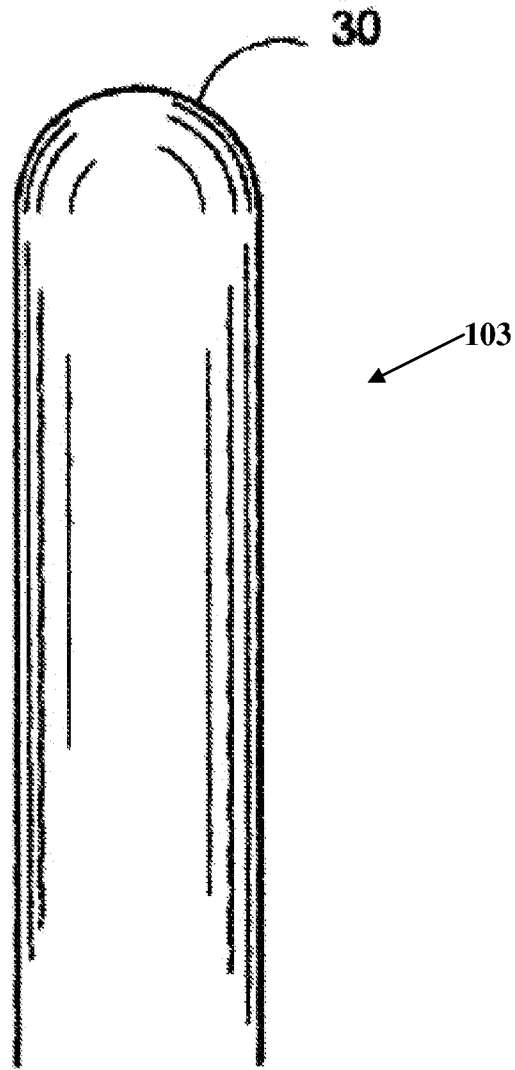

FIG. 9

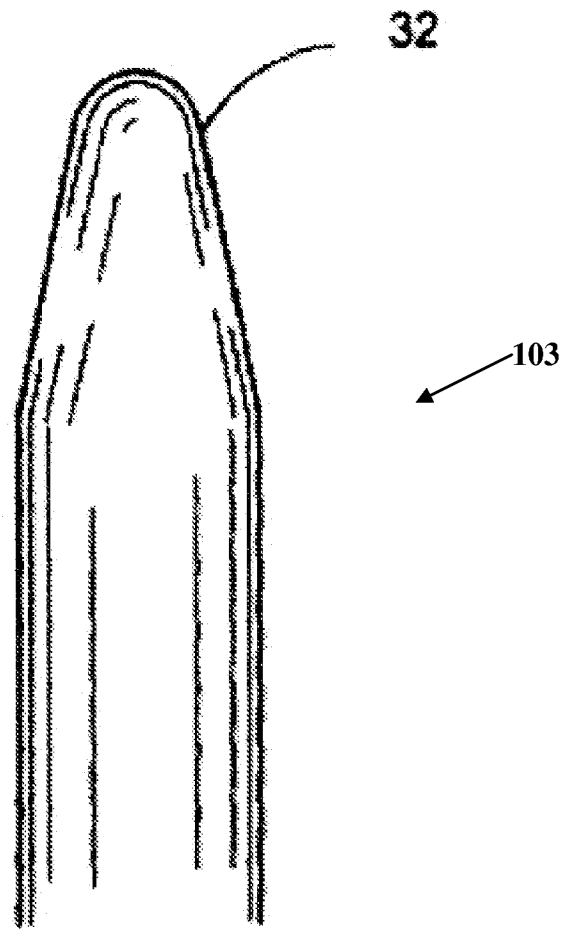

FIG. 10

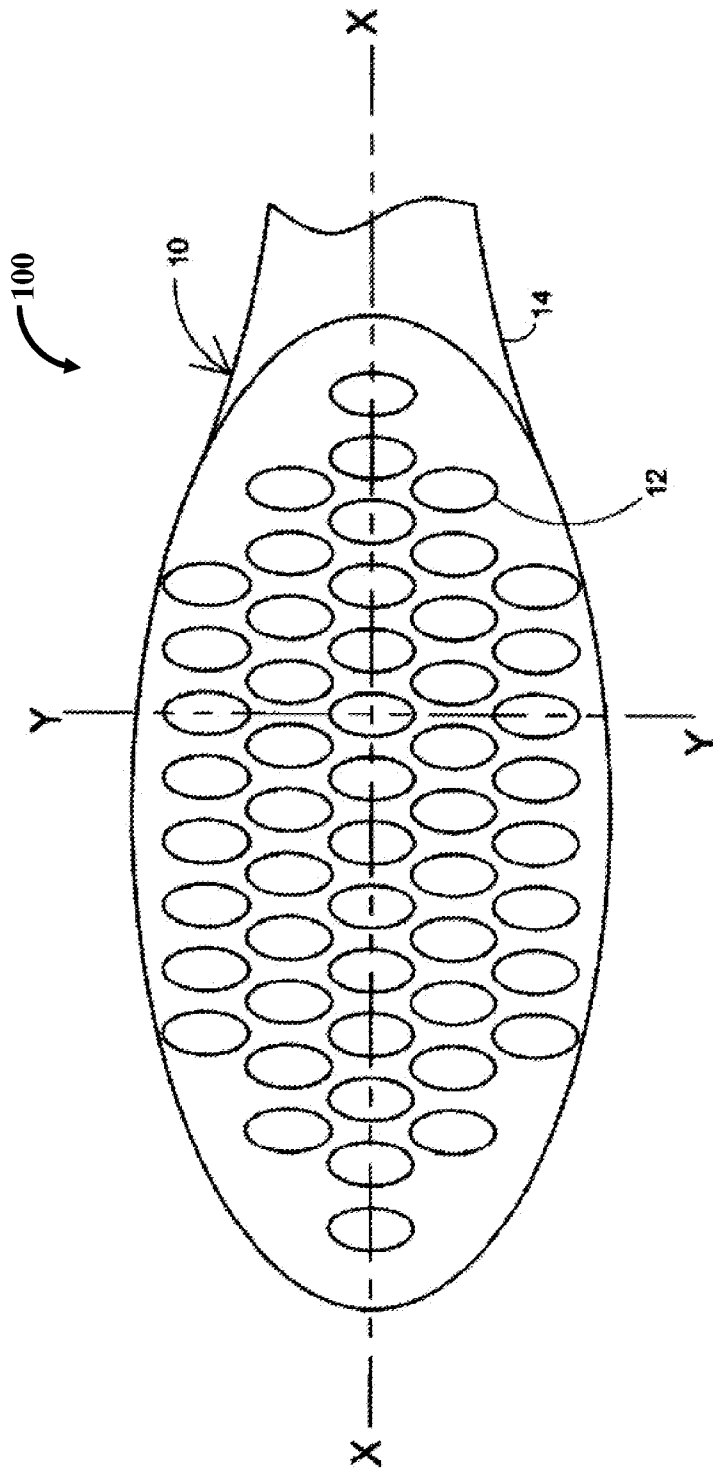

FIG. 11

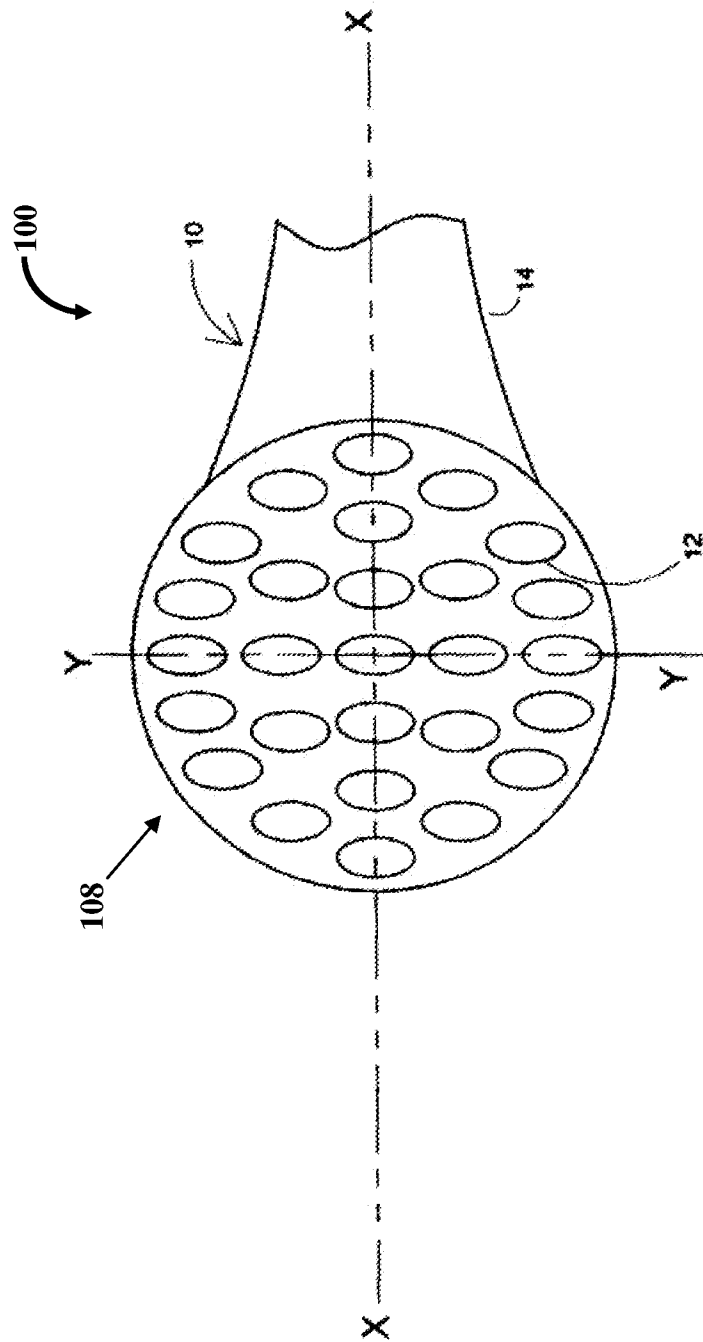

FIG. 12

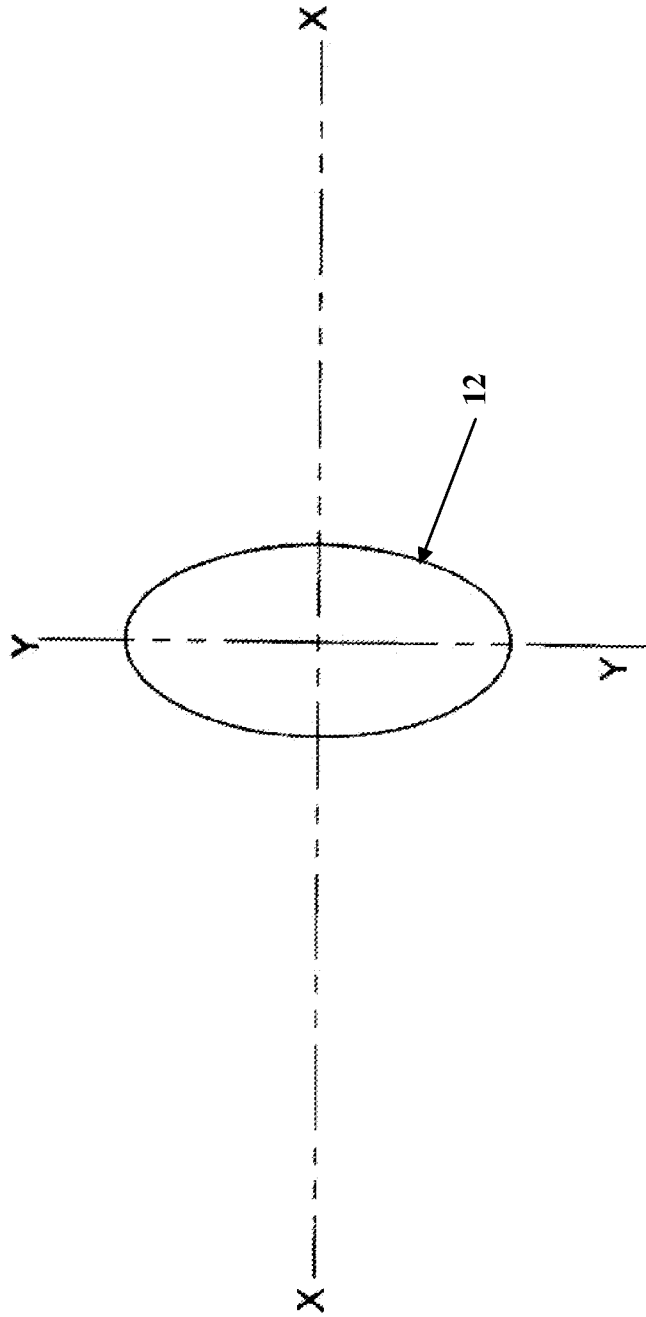

FIG. 13

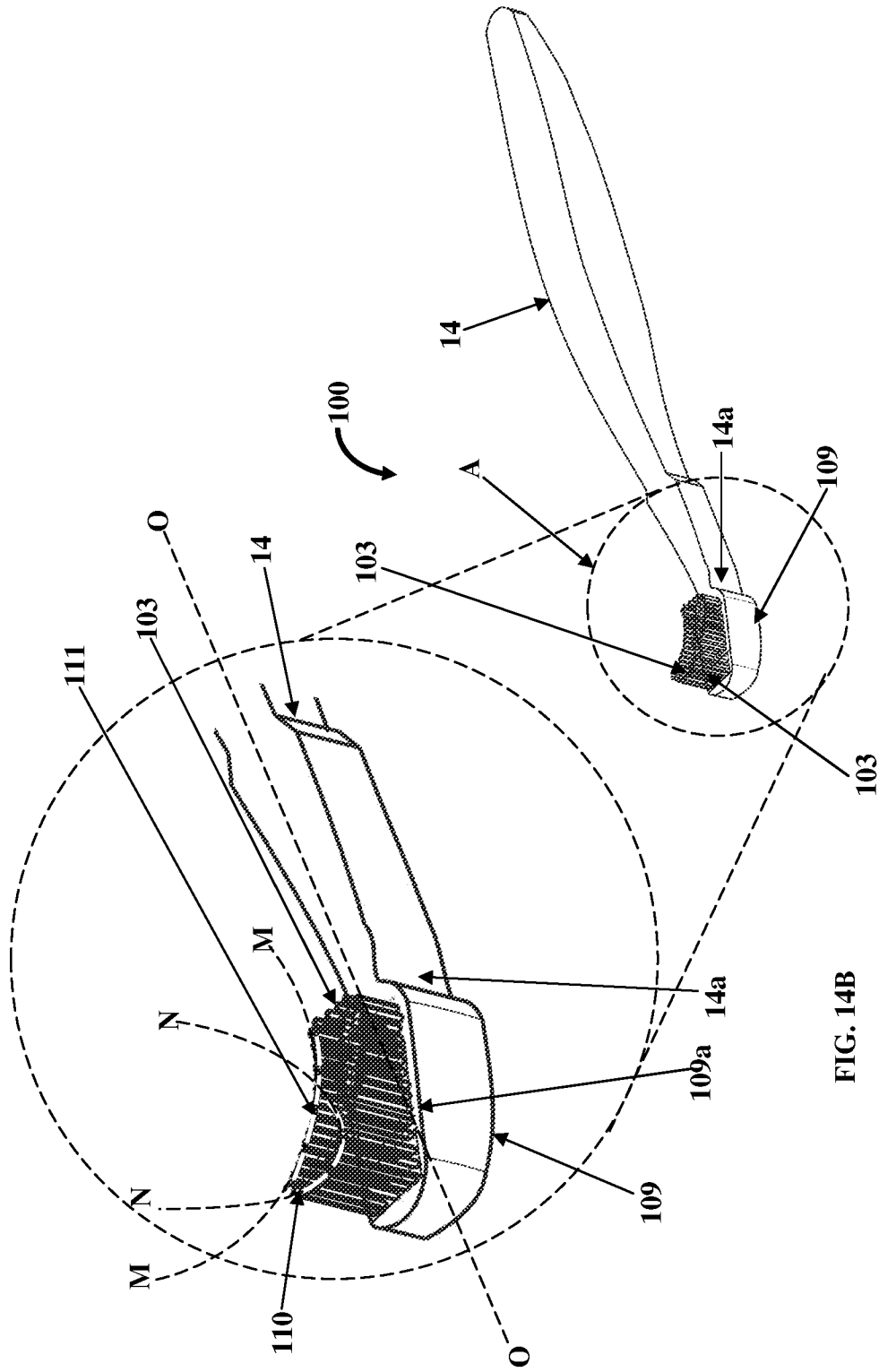

FIG. 14A

FIG. 14B

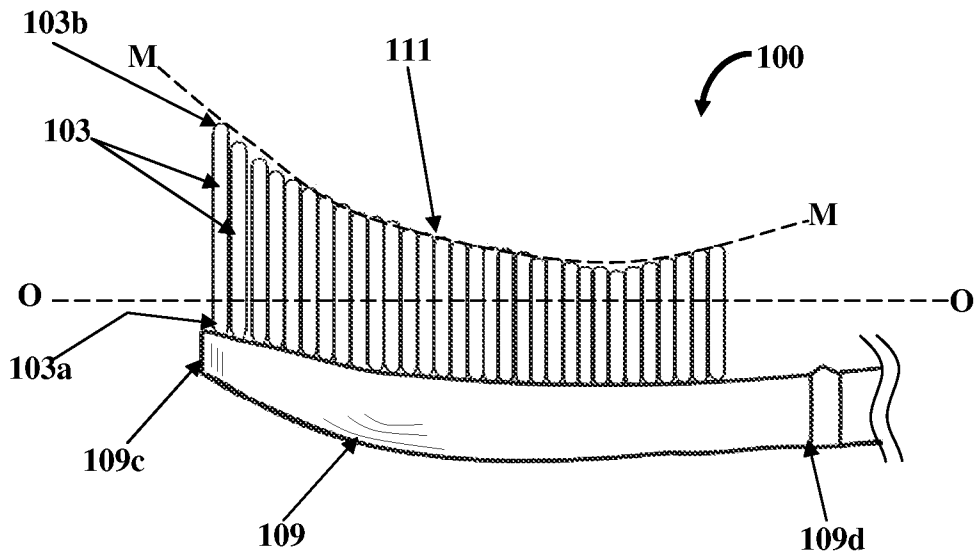

FIG. 16A

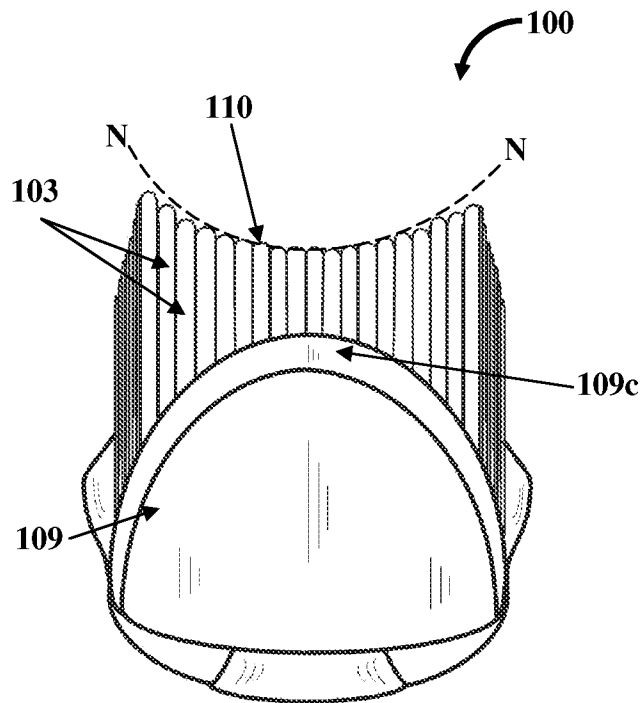

FIG. 16B

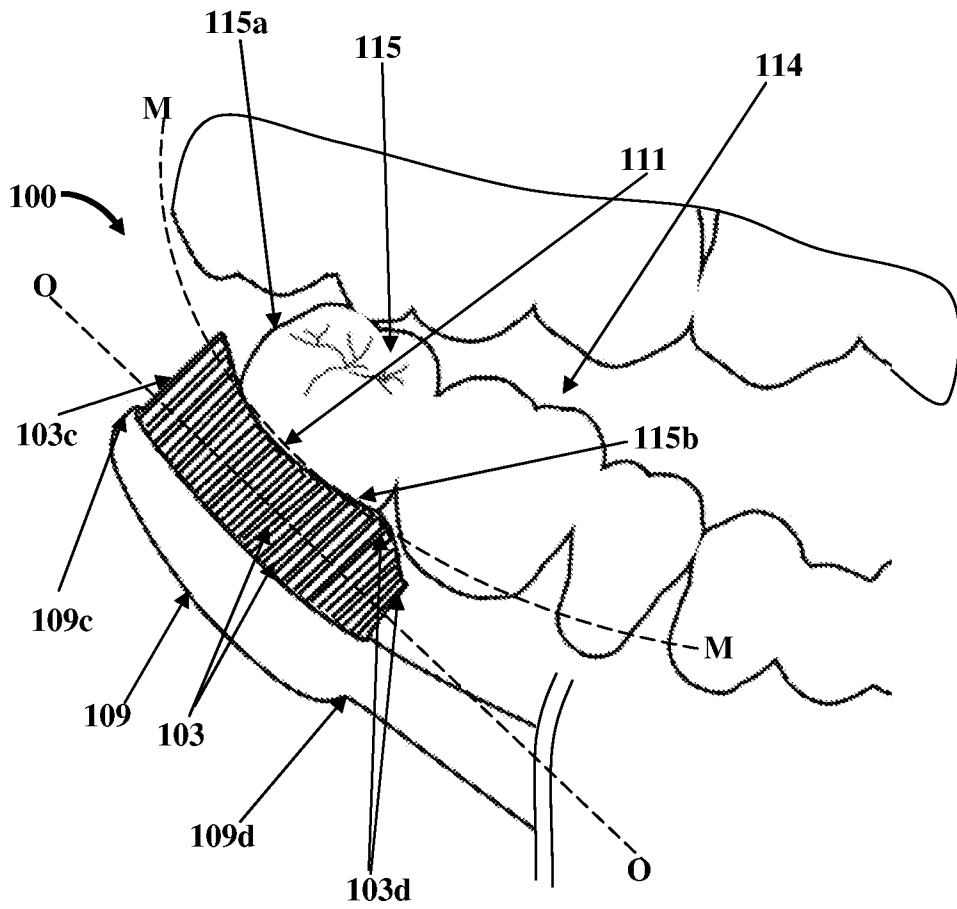

FIG. 17A

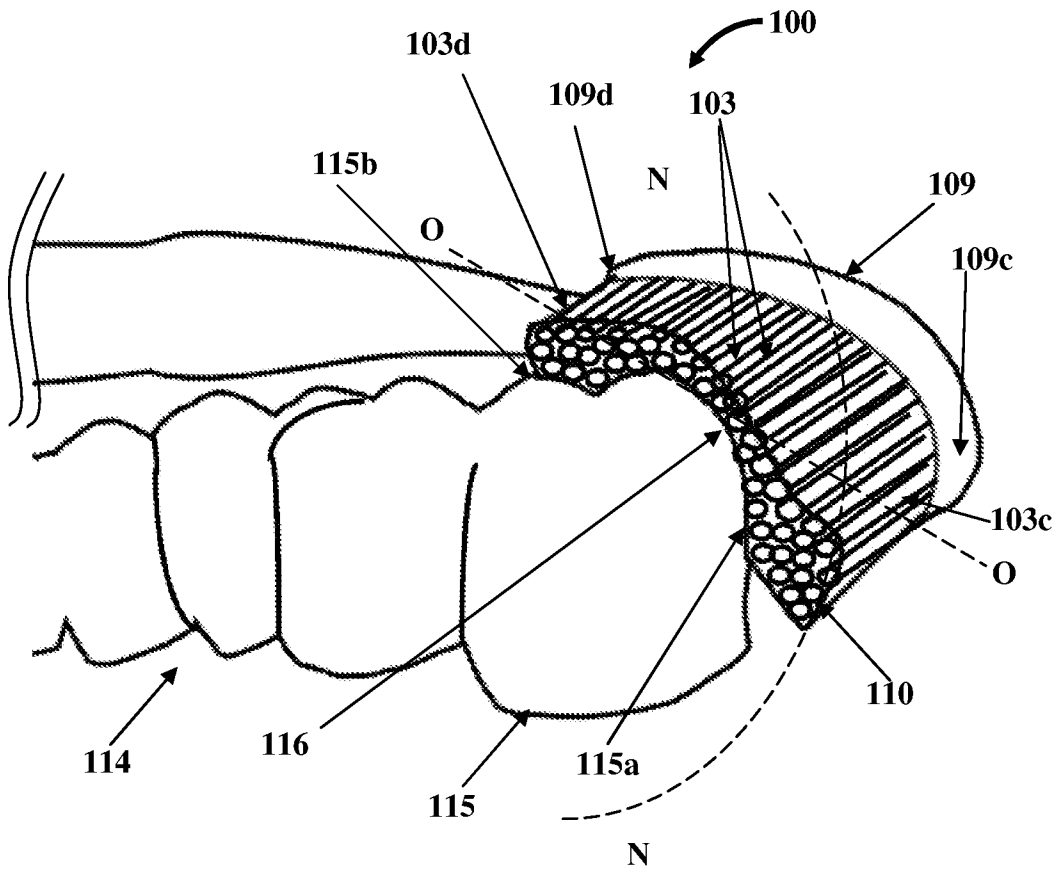

FIG. 17B

INTERNATIONAL SEARCH REPORT

International application No.

PCT/US 2014/070424

| A. CLASSIFICATION OF SUBJECT MATTER | | |
|---|---|--|
| <i>A46B 9/04 (2006.01)</i> | | |
| According to International Patent Classification (IPC) or to both national classification and IPC | | |
| B. FIELDS SEARCHED | | |
| Minimum documentation searched (classification system followed by classification symbols) | | |
| A46B 9/04 | | |
| Documentation searched other than minimum documentation to the extent that such documents are included in the fields searched | | |
| Electronic data base consulted during the international search (name of data base and, where practicable, search terms used) | | |
| Espacenet, DWPI | | |
| C. DOCUMENTS CONSIDERED TO BE RELEVANT | | |
| Category* | Citation of document, with indication, where appropriate, of the relevant passages | Relevant to claim No. |
| X | WO 2002/038004 A1 (GILLETE CANADA COMPANY et al.) 16.05.2002, abstract, p. 1, lines 4-15, p. 2, lines 31-32, p. 3, lines 1-3, fig. 1, 2 | 1-3 |
| X | US 2008/0184511 A1 (THE GILLETTE COMPANY) 07.08.2008, abstract, fig. 1A, 3C, 3B, 9A, 9B, 10B, 11A, 11B, 20A | 4-8 |
| Y | GB 2035076 A (JOSEF DOLINSKY) 18.06.1980, abstract, fig. 2, 3 | 9-11 |
| Y | JP 2008302164 A (KUBO HIROYUKI) 18.12.2008, abstract, fig. 1-39 | 9-11 |
| A | JP 2002325632 A (LION CORP) 12.11.2002 | 1-11 |
| A | US 5325560 A (PAVONE BERNADINO J et al.) 05.07.1994 | 1-11 |
| A | WO 1996/025866 A1 (LINGNER FISCHER GMBH et al.) | 1-11 |
| <input type="checkbox"/> Further documents are listed in the continuation of Box C. <input type="checkbox"/> See patent family annex. | | |
| * Special categories of cited documents: | “T” | later document published after the international filing date or priority date and not in conflict with the application but cited to understand the principle or theory underlying the invention |
| “A” document defining the general state of the art which is not considered to be of particular relevance | “X” | document of particular relevance; the claimed invention cannot be considered novel or cannot be considered to involve an inventive step when the document is taken alone |
| “E” earlier document but published on or after the international filing date | “Y” | document of particular relevance; the claimed invention cannot be considered to involve an inventive step when the document is combined with one or more other such documents, such combination being obvious to a person skilled in the art |
| “L” document which may throw doubts on priority claim(s) or which is cited to establish the publication date of another citation or other special reason (as specified) | “&” | document member of the same patent family |
| “O” document referring to an oral disclosure, use, exhibition or other means | | |
| “P” document published prior to the international filing date but later than the priority date claimed | | |
| Date of the actual completion of the international search | Date of mailing of the international search report | |
| 20 March 2015 (20.03.2015) | 09 April 2015 (09.04.2015) | |
| Name and mailing address of the ISA/RU: Federal Institute of Industrial Property, Berezhkovskaya nab., 30-1, Moscow, G-59, GSP-3, Russia, 125993 Facsimile No: (8-495) 531-63-18, (8-499) 243-33-37 | Authorized officer V. Vasilieva Telephone No. 8(495)531-65-15 | |

Box No. II Observations where certain claims were found unsearchable (Continuation of item 2 of first sheet)

This international search report has not been established in respect of certain claims under Article 17(2)(a) for the following reasons:

1. Claims Nos.:
because they relate to subject matter not required to be searched by this Authority, namely:
2. Claims Nos.:
because they relate to parts of the international application that do not comply with the prescribed requirements to such an extent that no meaningful international search can be carried out, specifically:
3. Claims Nos.:
because they are dependent claims and are not drafted in accordance with the second and third sentences of Rule 6.4(a).

Box No. III Observations where unity of invention is lacking (Continuation of item 3 of first sheet)

This International Searching Authority found multiple inventions in this international application, as follows:

The present international application lacks unity *a priori* within the meaning of Rule 13 PCT. Claims of the invention comprise 3 groups of inventions, which are not so linked as to form a single general inventive concept. There is no technical relationship among these groups of inventions involving one or more of the same or corresponding special technical features, the latter expression designating those features that define a contribution which each of the inventions, considered as a whole, makes over the prior art.

The first group of inventions comprises independent claim 1 refers to a toothbrush apparatus comprising a toothbrush head comprising at least one non-circular socket; and a plurality of bristles, wherein at least one of said bristles has an elliptical cross section is adapted to be accommodated in said at least one non-circular socket of said toothbrush head.

The second group of inventions comprises independent claim 4 and refers to a bristle comprising: an elongated bristle body having a first end and a second end, said second end of said elongated bristle body opposing said first end; and a wall defining said elongated bristle body, said wall continuously tapering from said first end towards said second end.

The third group of inventions comprises independent claim 9 and refers to a arcuate toothbrush head configured to conform to a dental arch, comprising one or more base sections on its upper surface; wherein the second end of each bristles is configured to define a first curved trim profile along a longitudinal axis of said toothbrush apparatus, wherein bristles in the first curved trim are configured to extend to reach a rear section of rear teeth along said dental arch.

1. As all required additional search fees were timely paid by the applicant, this international search report covers all searchable claims.
2. As all searchable claims could be searched without effort justifying additional fees, this Authority did not invite payment of additional fees.
3. As only some of the required additional search fees were timely paid by the applicant, this international search report covers only those claims for which fees were paid, specifically claims Nos.:
4. No required additional search fees were timely paid by the applicant. Consequently, this international search report is restricted to the invention first mentioned in the claims; it is covered by claims Nos.:

Remark on Protest

- The additional search fees were accompanied by the applicant's protest and, where applicable, the payment of a protest fee.
- The additional search fees were accompanied by the applicant's protest but the applicable protest fee was not paid within the time limit specified in the invitation.
- No protest accompanied the payment of additional search fees.