

No. 81,594.

PATENTED SEPT. 1, 1868

J. W. BURKHART.
HAND SPINNING MACHINE.

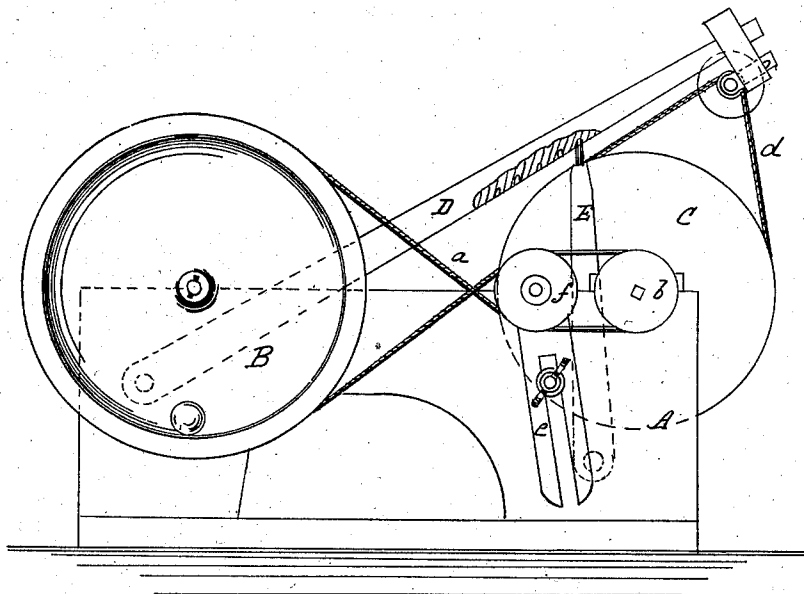

Witnesses.
Wm A Morgan
G. C. Cotton

Inventor
J. W. Burkhart
per Munnell
Attorneys

United States Patent Office.

J. W. BURKHART, OF CAMERON, MISSOURI.

Letters Patent No. 81,594, dated September 1, 1868.

IMPROVEMENT IN HAND-SPINNING MACHINERY.

The Schedule referred to in these Letters Patent and making part of the same.

TO ALL WHOM IT MAY CONCERN:

Be it known that I, J. W. BURKHART, of Cameron, in the county of Clinton, and State of Missouri, have invented a new and improved Hand-Spinning Frame; and I do hereby declare that the following is a full, clear, and exact description thereof, which will enable those skilled in the art to make and use the same, reference being had to the accompanying drawings, forming part of this specification.

The nature of my invention relates to improvements in the arrangement of the operating-mechanism of hand-spinning frames, and consists in an arrangement of the spindle upon a vibrating arm pivoted to the frame of the machine at one end, and borne upon the upper end of a vibrating lever, whose lower end is also pivoted to the frame, and is arranged to be adjusted with reference to the spindle-arm so as to elevate or depress the spindle-arm for the purpose of tightening the belt, and at the same time, and in connection therewith, providing a double-grooved pulley or an adjustable support, over which the belt from the main driving-wheel passes to the multiplying-wheel, in such a manner that the belt, in crossing itself, will not wear, and so that it may be adjusted toward or from the driving-wheel, also for tightening the first belt, as will be more fully described on reference to the accompanying drawings, wherein—

Figure 1 represents a side elevation of my improved machine.

B represents the main driving-wheel, provided with a journal fixed to the frame A, and a crank for operating it.

C represents a multiplying-wheel, which derives motion from the wheel B through the belt *a* and pulley *b*, and which communicates motion to the spindle by the belt *d*.

e represents a slotted and adjustable pulley-support, which is secured to the frame A by a set-screw, and carries at its upper end a double-grooved pulley, over which the crossed belt *a* works, in one of said grooves at the top, and in the other at the bottom of said wheel *f*, whereby the two parts are prevented from rubbing and chafing each other in passing.

When the belt *a* becomes loose, it may be tightened by adjusting the pulley toward the pulley B.

D represents the spindle-arm, which is pivoted to the frame A, near the front end thereof, and projects forward in an upwardly-inclined position, holding the spindle above the wheel C.

E represents a supporting-arm for the spindle-arm, on which the latter rests, which is provided with notches for catching on to the upper end of the arm E, which latter is pivoted, at its lower end, to the frame A, as shown in dotted lines.

To tighten the belt *d*, the arm D is raised, and the arm F moved into a notch near the driving-wheel or the fulcrum of the arm D.

I claim as new, and desire to secure by Letters Patent—

The combination of the pulley B, tightening-pulley *f*, provided with its adjustable support *e*, pulley *b*, and multiplying-wheel C, spindle-arm D, and adjustable support E of the same, when constructed and arranged substantially as and for the purpose described.

J. W. BURKHART.

Witnesses:

NELSON DUNCAN,
JACOB HOOPER.