

H. ULLRICH.
WATER MASSAGE APPARATUS.

(Application filed Apr. 24, 1899.)

(No Model.)

Fig. 1.

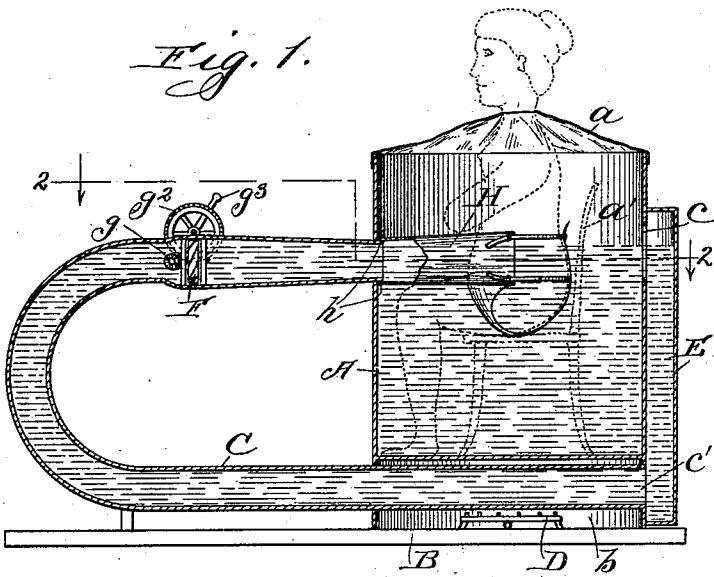

Fig. 2.

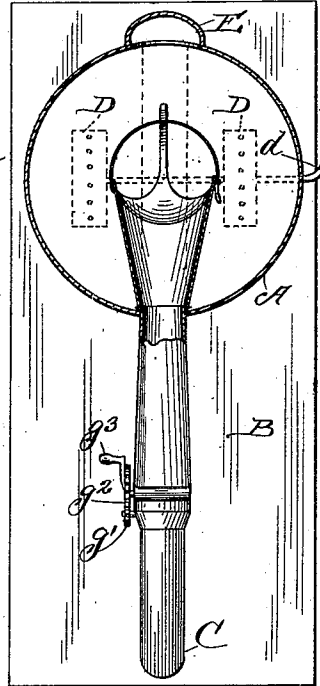

Fig. 5.

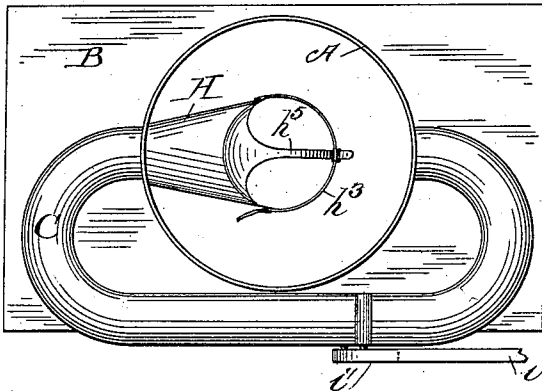

Fig. 3.

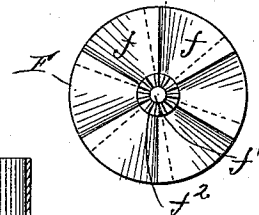

Fig. 4.

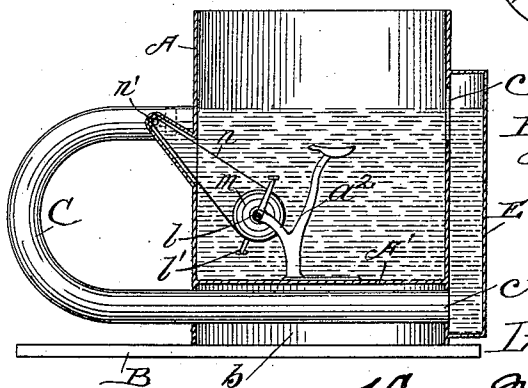
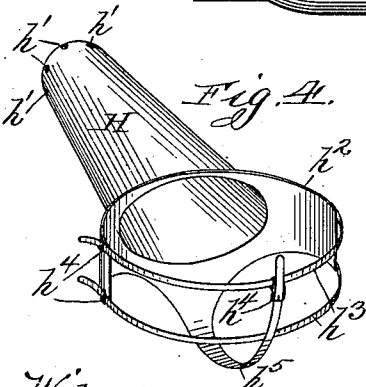

Fig. 6.

Witnesses:
 R. J. Jacker,
 A. Gustafson

Inventor:
 Henry Ullrich.
 By Chas. Pittman,
 Atty.

UNITED STATES PATENT OFFICE.

HENRY ULLRICH, OF CHICAGO, ILLINOIS.

WATER-MASSAGE APPARATUS.

SPECIFICATION forming part of Letters Patent No. 640,837, dated January 9, 1900.

Application filed April 24, 1899. Serial No. 714,301. (No model.)

To all whom it may concern:

Be it known that I, HENRY ULLRICH, a citizen of the United States, residing at Chicago, in the county of Cook and State of Illinois, have invented certain new and useful Improvements in Water-Massage Apparatus, of which the following is a specification.

This invention relates to improvements in an apparatus to be used for therapeutically treating or administering to the human body or organization or portions thereof a massage treatment, and while it is more especially designed for the use of women in the treatment of diseases peculiar to the female sex, yet it may be employed by men; and it consists in certain peculiarities of the construction, novel arrangement, and operation of the various parts thereof, as will be hereinafter more fully set forth and specifically claimed.

The objects of my invention are, first, to provide an apparatus of the above-described character which shall be simple and inexpensive in construction and strong and durable; second, such an apparatus which shall be so constructed as to afford a continuous flow of air and water through a conduit, the force and pressure of air and water being regulated to the desired degree and its course directed to the proper portion of the body of the patient or person using the apparatus, and, third, to provide an apparatus of the character described which may be operated by the patient or user or by an assistant.

Another object is to afford a means for thermal or other kind of bath which may be taken with or without massage treatment.

In order to enable others skilled in the art to which my invention pertains to make and use the same, I will now proceed to describe it, referring to the accompanying drawings, in which—

Figure 1 is a central vertical sectional view of my apparatus, showing the parts in position ready for use. Fig. 2 is a plan sectional view taken on line 2 2 of Fig. 1. Fig. 3 is a detached view of the power or water wheel. Fig. 4 is a perspective view of the guiding tube or conduit detached. Fig. 5 is a plan view of the apparatus, showing a modification in its construction, and Fig. 6 is a vertical sectional view, partly in elevation, showing

another modification in the construction of the apparatus.

Similar letters refer to like parts throughout the different views of the drawings. 55

A represents the tub or receptacle for the patient or user and which may be made of any suitable size, form, and material, but preferably of sheet metal and cylindrical in form, as shown in the drawings. The upper portion of the tub or vessel A is open, but may be closed by means of a cover *a*, of rubber or other suitable material, which cover may be provided in its center with an opening to fit around the neck of the patient or user. 60 65

The lower portion of the tub or vessel A is provided with a floor A', on which may rest a chair *a'* or other suitable support for the user. As shown in Figs. 1 and 6 of the drawings, the floor A' of the tub or vessel is located some distance from the base B, on which the lower end of the tub or vessel rests, and thus forms a compartment *b*, through which the conduit C passes and in which may be located burners D of the ordinary or any preferred construction, and which burners may be supplied with fuel through a pipe *d*, leading from a source of fuel-supply. (Not shown.) 70 75

The upper portion of the vessel or tub A is provided with an opening *c*, which communicates with a pipe or conduit E, which extends to the lower portion of the tub or vessel and has an opening *c'* for communication with the pipe or conduit C, which is formed with a curve, as shown in Figs. 1 and 6 of the drawings, and has its upper end communicating with the tub or vessel. Journaled within the upper portion of the pipe or conduit C is a power or water wheel F, which comprises a series of spiral blades *f*, similar to those used on a propeller for boats. Mounted on the shaft *f'* of the wheel F is a gear *f*², which meshes with the gear *g*, located on a shaft journaled transversely in the pipe C, and which has on its outer end a gear *g'* to engage the gear *g*², which is journaled on the upper portion of the pipe C and is provided with a crank-handle *g*³ to be used for operating the wheel to force water through the conduit and vessel. As shown in Fig. 1 of the drawings, the upper end of the pipe C extends a slight distance into the vessel or tub A and may be 80 85 90 95 100

provided with projections h to engage openings h' in the guiding tube or pipe H, which may be made of canvas or other suitable material and has its inner or free end provided with a band h^2 , to one end of which are secured straps h^3 , whose other ends may be secured to the opposite end of the band h^2 by means of buckles h^4 or otherwise. Extending from the lower portion of the band h^2 is a strap h^5 , which may be secured to one of the straps h^3 by means of a buckle h^4 or otherwise.

In Fig. 5 of the drawings I have shown a modification in the construction of my apparatus which consists in placing the pipe or conduit C so that a portion thereof will be located to one side of the tub or vessel and will have its ends communicating directly with the vessel instead of through the instrumentality of the pipe or conduit E, as shown in Figs. 1 and 6 of the drawings. The wheel F may be driven by means of a belt i , applied to a pulley i' , journaled on the pipe C and geared to the shaft of the wheel.

In Fig. 6 of the drawings I have shown still another modification, which consists in providing the seat or support a^2 with a crankshaft l , on which is mounted a pulley m , around which passes a belt n , which also passes around the pulley n' on a shaft journaled in the pipe or conduit C and geared to the shaft of the power or water wheel.

By employing the construction illustrated in Fig. 6 of the drawings and above described it is evident that the water may be forced through the pipe or conduit C by the user placing his feet on the pedals l' of the crank, and thereby turning the same, which operation will cause the power or water wheel to rotate.

The operation of my apparatus is simple, as follows: A sufficient quantity of water may be placed within the vessel or tub A, so as to fill it to a point about level with the upper part of the supply portion of the pipe or con-

duit. The guiding-tube H, which may be secured to said portion of the pipe or conduit in any desired manner, may then be fastened to that portion of the body which it is desired to treat or massage by means of the straps h^3 h^5 , so as to hold the band h^2 close to the body. By operating the power or water wheel, which may be done by hand or foot power or by means of an electric or other suitable motor, the water and air will be forced through the conduit C with the desired force and against the portion of the body under treatment, the guide-tube H being located so that a portion thereof will lie a slight distance above the surface of the water in the vessel, thus allowing the air and water to intermingle.

The guiding pipe or tube H being made of material more or less flexible, it is evident that the volume of water forced through the conduit C may be directed or guided in its course. It is also apparent that by using the burners D the water within the vessel may be heated to any desired degree of temperature.

Having thus fully described my invention, what I claim as new, and desire to secure by Letters Patent, is—

1. The combination with a tub or vessel, of a conduit communicating therewith, a guiding-tube secured to the outlet portion of said conduit and having means to fasten it to the body of the person, a wheel located in the conduit, and means to drive said wheel, substantially as described.

2. The combination with a tub or vessel, of a conduit communicating therewith, means for circulating the water through the conduit and vessel, a guiding-tube secured to the outlet portion of said conduit, said tube having the band h^2 , provided with straps h^3 , and the strap h^5 , substantially as described.

HENRY ULLRICH.

Witnesses:

CHAS. C. TILLMAN,
A. GUSTAFSON.