



(12) **EUROPEAN PATENT APPLICATION**

(43) Date of publication:  
**10.06.2009 Bulletin 2009/24**

(51) Int Cl.:  
**A63G 9/00 (2006.01)**

(21) Application number: **08170543.6**

(22) Date of filing: **03.12.2008**

(84) Designated Contracting States:  
**AT BE BG CH CY CZ DE DK EE ES FI FR GB GR HR HU IE IS IT LI LT LU LV MC MT NL NO PL PT RO SE SI SK TR**  
 Designated Extension States:  
**AL BA MK RS**

(71) Applicant: **Lappset Group Oy**  
**96101 Rovaniemi (FI)**

(72) Inventor: **Linna, Saara**  
**90570, Rovaniemi (FI)**

(30) Priority: **04.12.2007 FI 20070937**

(74) Representative: **Brax, Matti Juhani**  
**Berggren Oy Ab,**  
**P.O. Box 16**  
**00101 Helsinki (FI)**

(54) **Family swing**

(57) A swing seat comprises a first seat portion (201, 303, 703, 1403, 1503), a first hanging point and a second hanging point. The first hanging point is at a distance from said second hanging point in a longitudinal direction (204) of the swing seat. Thus the swinging direction (205, 206) is perpendicular to said longitudinal direction (204). The swing seat comprises a second seat portion (202,

301, 401). Both the first (201, 303, 703, 1403, 1503) and the second (202, 301, 401) seat portion are formed to offer a sitting position for a player, with a front direction of a player sitting in the sitting position being parallel with the swinging direction (205, 206). The second seat portion (202, 301, 401) is displaced from said first seat portion (201, 303, 703, 1403, 1503) in the longitudinal direction (204) of the swing seat.

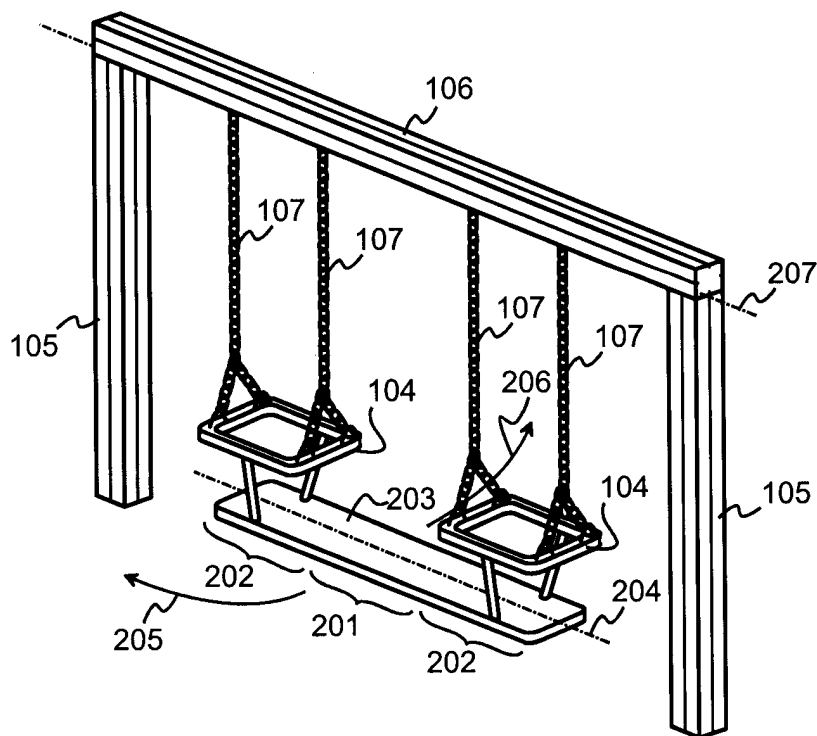

**Fig. 2**

## Description

### TECHNICAL FIELD

**[0001]** The invention concerns the technology of mechanical playground appliances. Especially the invention concerns seat structures for swings that enable a number of persons to swing together.

### BACKGROUND OF THE INVENTION

**[0002]** Swinging is one of the most traditional playground games. The required equipment is simple, it is easy to make the swing relatively safe and mechanically reliable, and the excitement generated by the dynamic movement and the feeling of weightlessness appeal to young and old players alike.

**[0003]** For the purposes of the following description a playground is understood to be a place equipped for activities that aim at cognitive, motoric and social development and education through an attractive and amusing way. An amusement park is not a playground, because it only aims at producing experiences of amusement and excitement without said educational function. In practice an amusement park is always built for occasional visits, manned with personnel, and subject to charge. A playground is nearly always unmanned and freely accessible for regular visits by players. As a consequence, there is a remarkable difference between equipment meant for use in amusement parks and equipment meant for use on playgrounds. At amusement parks the rides are typically so wild that careful security measures under the constant supervision of trained personnel must be applied to avoid serious injury or death. Playground equipment is built for inherent security, enabling even very small children to play and explore relatively independently.

**[0004]** Alternatively a playground may be defined to be a place equipped with playthings that obey the appropriate standards, which in Europe means a standard known as EN 1176 for equipment and another known as EN 1177 for materials. Other standardisation domains have their own, comparable standards about playground equipment.

**[0005]** Fig. 1 illustrates schematically a known playground swing. Shown on the right in the drawing is a swing with an ordinary seat 101. For the safety of very small children it is common to use a safety seat 102. Safety seats come in numerous different shapes and designs but they typically comprise at least a lower part 103 for the child to sit on and a ring part 104 supported above the lower part 103 to keep the child from falling sideways from the sitting position. A support frame, typically comprising one or more vertical support beams 105 and a horizontal support beam 106, is used to hang the swing seats freely so that swinging back and forth becomes possible. Pliable supports, such as cords or chains 107, or in some case rigid poles, are used to hang the swing

seats 101 and 102 from the horizontal support beam. Hinged joints (not shown) are typically used at the upper ends of said pliable supports, and are necessary especially if rigid poles are used. To enhance the stability of the swing seat, the lower ends of the cords or chains 107 may have two or more branches (not shown) attached to different locations (like front edge - rear edge) of the seat.

**[0006]** Prior art documents that illustrate various known features of playground swings are for example GB 2 195 550 A and US 3,663,016.

**[0007]** Known playground swings have the inherent problem that their mechanical structure does not offer enough motivation or even possibility to make swinging an activity for the whole family with small children, otherwise than allowing the standing adult to give more momentum by pushing the swinging child from back. Another problem of swings with safety seats is that despite of all efforts put into ensuring the small player's safety it is possible that the child somehow manages to fall out of the safety seat or to otherwise hurt him- or herself during the swinging movement.

### SUMMARY OF THE INVENTION

**[0008]** An objective of the invention is to provide a playground swing that motivates and enables smaller and larger players to enjoy swinging with shared amusement and joy. Another objective of the invention is to enhance the safety of small children during swinging. Yet another objective of the invention is to mitigate and avoid problems and drawbacks typical to prior art playground swings.

**[0009]** The objectives of the invention are achieved by providing a combination seat for a swing, on which combination seat at least two players can sit and swing together.

**[0010]** A swing seat according to the invention comprises a first seat portion, a first hanging point and a second hanging point. The first hanging point is located at a distance from said second hanging point in a longitudinal direction of the swing seat, thus defining a swinging direction that is perpendicular to said longitudinal direction of the swing seat. The swing seat is characterized in that:

- the swing seat comprises a second seat portion,
- both the first and the second seat portion are formed to offer a sitting position for a player, with a front direction of a player sitting in the sitting position being parallel with the swinging direction, and
- said second seat portion is displaced from said first seat portion in the longitudinal direction of the swing seat.

**[0011]** A playground swing according to the invention comprises a swing seat with a first seat portion, a support frame, a first vertical support connecting a first hanging point of the swing seat to the support frame, and a second

vertical support connecting a second hanging point of the swing seat to the support frame. The first vertical support is located at a distance from said second vertical support in a longitudinal direction of the swing seat, thus defining a swinging direction that is perpendicular to said longitudinal direction of the swing seat. The playground swing is characterized in that:

- the swing seat comprises a second seat portion,
- both the first and the second seat portion are formed to offer a sitting position for a player, with a front direction of a player sitting in the sitting position being parallel with the swinging direction, and
- said second seat portion is displaced from said first seat portion in the longitudinal direction of the swing seat.

**[0012]** A combining part for a playground swing according to the invention is characterised in that for turning a playground swing with at least a first individual swing seat into a family swing the combining part comprises:

- a first end, and
- in said first end mechanical attachment means for attaching to a side of said first individual swing seat, and is further characterized in that the combining part is adapted to offer a sitting position for a player, with a front direction of a player sitting in the sitting position being parallel with a swinging direction of said first individual swing seat.

**[0013]** According to the present invention, a combination seat can be provided, which comprises sitting places or seat portions for at least two players. The combination seat may comprise for example at least one safety seat and at least one ordinary seat, or it may comprise a number of ordinary seats in a row.

**[0014]** The general term "safety seat" means a swing seat or seat portion that comprises a lower part and a ring part or other support means supported above the lower part to keep a child sitting on the lower part from falling sideways from the sitting position. The general term "ordinary seat" means a swing seat or seat portion that has a sitting part dimensioned so that a player may sit on it and swing regardless of whether the player is of the size of a child or of the size of an adult. The combination seat also comprises hanging points for allowing it to hang from a support structure above it, suspended by pliable supports, such as cords or chains, or rigid poles with hinged joints allowing a swinging movement. Responsible manufacturers of swings ensure that the seats and the swings as a whole conform with part 2 of the standard EN 1176, or with the appropriate other standard concerning playground swings applicable under different legislations.

**[0015]** A larger player, such as an adult, may sit or otherwise place him- or herself onto the ordinary swing seat, while a smaller player, such as a small child, is

placed into the safety seat. Each seat portion is formed to offer a sitting position for a player, with a front direction of a player sitting in the sitting position being parallel with the back-and-forth swinging direction. The smaller and larger player may then enjoy the thrill and excitement of swinging together, facing e.g. the same direction or opposite directions. The larger player remains constantly very close to the smaller player during the swinging movement, so that he or she may control the actions of the smaller player and ensure safety even in sudden surprising situations.

**[0016]** The combination seat may be a single mechanical entity manufactured especially for this purpose. Alternatively it is possible to produce a combination seat by attaching a safety seat and an ordinary seat together, or by attaching two swing seats (safety seats and/or ordinary seats) together with a combining part, which itself constitutes at least one seat portion in the combined structure.

**[0017]** The exemplary embodiments of the invention presented in this patent application are not to be interpreted to pose limitations to the applicability of the appended claims. The verb "to comprise" is used in this patent application as an open limitation that does not exclude the existence of also unrecited features. The features recited in depending claims are mutually freely combinable unless otherwise explicitly stated.

**[0018]** The novel features which are considered as characteristic of the invention are set forth in particular in the appended claims. The invention itself, however, both as to its construction and its method of operation, together with additional objects and advantages thereof, will be best understood from the following description of specific embodiments when read in connection with the accompanying drawings.

#### BRIEF DESCRIPTION OF DRAWINGS

##### **[0019]**

- Fig. 1 illustrates a prior art playground swing,
- fig. 2 illustrates a playground swing according to an embodiment of the invention,
- fig. 3 illustrates a swing seat and a combining part according to an embodiment of the invention,
- fig. 4 illustrates a swing seat and a combining part according to another embodiment of the invention,
- fig. 5 illustrates a swing seat and a combining part according to another embodiment of the invention,
- fig. 6 illustrates a swing seat and a combining part according to another embodiment of the invention,
- fig. 7 illustrates a swing seat and a combining part according to another embodiment of the invention,
- fig. 8 illustrates a swing seat according to another

- embodiment of the invention,  
 fig. 9 illustrates a swing seat according to another  
 embodiment of the invention,  
 fig. 10 illustrates a swing seat according to another  
 embodiment of the invention,  
 fig. 11 illustrates a swing seat according to another  
 embodiment of the invention,  
 fig. 12 illustrates a swing seat according to another  
 embodiment of the invention,  
 fig. 13 illustrates a swing seat having three safety  
 seats,  
 fig. 14 illustrates a swing seat according to another  
 embodiment of the invention,  
 fig. 15 illustrates a swing seat according to another  
 embodiment of the invention,  
 fig. 16 illustrates a swing seat according to another  
 embodiment of the invention, and  
 fig. 17 illustrates a swing seat according to another  
 embodiment of the invention.

#### DETAILED DESCRIPTION OF THE INVENTION AND ITS ADVANTAGEOUS EMBODIMENTS

**[0020]** Fig. 2 illustrates a playground swing according to an embodiment of the invention. This swing can also be called a family swing, because it accommodates at least one adult or large player together with two small children. The swing seat is a combination seat, and can be conceptually divided into an ordinary seat portion 201 in the middle and a safety seat portion 202 at each end of the ordinary seat portion 201. A first mechanical part of the combination seat is a lower part 203, which in this exemplary embodiment has a plank-like elongated form which defines the longitudinal direction 204 of the swing seat. Said longitudinal direction is horizontal and perpendicular against the principal swinging direction, which is illustrated with arrows 205 and 206. Supported above each end of the lower part 203 is a ring part 104, so that in each case the ring part and the portion of the lower part 203 directly below it together constitute a safety seat portion 202. The middle portion of the lower part 203, which is not directly below any of the ring parts 104, constitutes the ordinary seat portion 201.

**[0021]** A safety seat portion 202 is formed to offer a sitting position for a player, with the front direction of the player facing the direction of either arrow 205 or arrow 206. This is accomplished typically by making the ring part 104 wider sideways (i.e. in the longitudinal direction 204 of the swing seat), and by placing the supports that join the lower part and the ring part so that the player's legs naturally come pointing obliquely forward in the sitting position. An ordinary seat portion 201 offers more versatility, but it too is formed to offer for a player the most natural sitting position so that the front direction of the player is parallel with the swinging direction. Being offered a plank-like bench a human being most naturally sits on it with his legs and whole front direction directed into one direction perpendicular to the longitudinal direc-

tion of the bench. The sitting position is also partly defined by the chains or other vertical supports at the ends of the ordinary seat portion 201, because the player most naturally grabs one vertical support on each side with his or her hands.

**[0022]** Vertical supports, which in fig. 2 are pliable and appear in the form of chains 107, attach to hanging points in the swing seat and connect the swing seat to the horizontal support beam 106 of a support frame. In place of the chains 107 one could use cords or other known pliable support means, or even rigid poles if their upper ends would be connected to the support frame with hinged joints. As in known playground swings, it is advantageous to use hinged joints at the upper ends even if the support means are pliable, like the chains 107 of fig. 2. Likewise it is in many cases advantageous to make the lower ends of the pliable supports branch and attach to a pair of adjacent locations to increase stability. From the viewpoint of the swinging movement the adjacent locations to which the branches go constitute a single hanging point, because it is the mutual displacement of hanging points in the longitudinal direction of the swing seat that defines the principal swinging direction.

**[0023]** The exact form and structure of the support means are not of importance to the present invention, as long as the support means enable swinging the swing seat in the principal swinging direction, i.e. direction of arrows 205 and 206, around an axis of rotation 207 that is conceptually located at or very close to the horizontal support beam 106. Small children sitting in a safety seat do not necessarily need any chains or other vertical supports on both sides, so in the structure of fig. 2 the rightmost and leftmost chains could be left out. For a person sitting on an ordinary seat it is advantageous to offer some vertical support on both sides, for which reason the two middle chains in fig. 2 should be there unless there are handrests, handles or the like (not shown) extending upwards from the lower part 203 on those sides of the middle portion with no chain.

**[0024]** It is advantageous, but not necessary, that all seat portions in swing seats according to embodiments of the invention are separated from each other by hanging points located between them, and there are hanging points also at the ends of the swing seat. Thus each of the first, second and third seat portions is located between hanging points so that there is one hanging point on each side of each seat portion. A support (typically pliable, e.g. chain) attached to a hanging point offers a gripping place for each player, and helps to keep the players from sliding onto each other's seat portions especially if there are ordinary seat portions side by side in the swing seat. Placing a hanging point between seat portions also helps in making the structure sturdy enough and mechanically stable.

**[0025]** In order to conform with the standard EN 1176, part 2, the structure shown in fig. 2 must have certain characteristics. A natural requirement is that the material strength of all components must be sufficient to withstand

normal use for swinging. The minimum ground clearance between the seat and ground is defined so that it must be 350 millimetres, except for tyre seats for which it is 400 millimetres. The seat of fig. 2 is not a tyre seat, so the former number is applicable. In impact testing the seat shall not give rise to peak values of acceleration greater than 50g and average surface compression shall not exceed 90N/m. Although fig. 2 only shows the combination seat alone in the support frame, in principle it is possible to use it together with other swing seats in the same frame, as long as the minimum space between seats is calculated according to the standard, taking the beam height into account.

**[0026]** Also it should be noted that older versions of the standard used to forbid placing separate safety seats and separate ordinary seats together in the same bay of the support frame. The purpose of this limitation was to protect small children using a safety seat from impacts caused by a larger player swinging in a nearby ordinary seat. The standard obviously does not take into account novelty products such as the combination seat, but since the combination seat of fig. 2 includes safety seats, it would be reasonable to assume that if a separate seat is additionally used in the same bay, according to the older versions of the standard it should be a safety seat. However, since the combined weight of players using a combination seat like that in fig. 2 will be considerable compared to a small child alone in a separate safety seat, to be on the safe side it is recommendable to use the combination seat alone in its bay.

**[0027]** Fig. 3 illustrates a way of using a combining part according to an embodiment of the invention to produce a swing seat according to an embodiment of the invention. The two seat portions at the extremities of the swing seat are constituted of individual swing seats that could also be used as such like in prior art swings. The structure of fig. 3 comprises two safety seat portions 301 and 302, which can be made of known safety seats by providing suitable attachments, and a combining part 303 fixedly attached to both safety seats so that it constitutes a kind of a flat bridge between them. The attachment is made with fasteners 304, which can be any type of suitable mechanical fasteners. The combining part 303 forms an ordinary swing seat portion for an adult or larger child who can thus swing together with one or two smaller children. Depending on the length of the combining part 303 also e.g. two middle-sized children could sit on it side by side.

**[0028]** In fig. 3, as well as in other embodiments illustrated in the drawings, the seat portions that together constitute the combination seat are dimensioned so that the sitting height of all seats is essentially the same, i.e. the supporting surfaces on which the players are expected to sit are all essentially on the same level. This is not a binding requirement of the invention; for example in the embodiment of fig. 3 it could be possible to make the middle player sit considerably higher or considerably lower than the players sitting in the safety seat portions just

by selecting the attaching height on which the combining part is attached to the safety seats, and by designing the combining part to have the desired upwards-bulging or downwards-bending shape. Basically the invention does not limit the selection of sitting heights of any of the seat portions that constitute the combination seat. However, reasons like safety, structural simplicity or ergonomics in use may lead it to being advantageous to have all players sit on essentially the same level, or to have the small children in the safety seat portions sit only slightly higher than the other players sitting on ordinary seat portions.

**[0029]** Fig. 4 illustrates another way of producing a swing seat according to an embodiment of the invention. The combining part 303 is similar to that used in fig. 3, but this time it is used to join two ordinary seats 401 and 402 to form a combination seat that comprises three ordinary seat portions and no safety seats. If the spacing between seats is the same, it is possible to use an exactly similar combining part 303 in the embodiments of both figs. 3 and 4. Alternatively, since there are differently spaced swings depending on the height of the support frame, it is possible to produce a number of differently dimensioned combining parts according to the invention, from which a suitably dimensioned one can be selected for each particular installation. The combining part 303 could also have a telescopic structure that allows it to be lengthened and shortened according to need.

**[0030]** Fig. 5 illustrates using a combining part 303 to produce a combination seat so that a safety seat portion 301 and an ordinary seat portion 402 are attached together.

**[0031]** A combining part according to an embodiment of the invention is not necessarily a plank-like piece, neither does it necessarily constitute an ordinary seat portion in the combined structure. Fig. 6 illustrates an embodiment of the invention in which a combining part 603 comprises a lower part 601 and a ring part 602 (or other support means) supported above the lower part to keep a child sitting on the lower part from falling sideways from the sitting position. Thus the combining part 603 constitutes a safety seat portion according to the standard EN 1176, part 2, in the combination seat thus formed. Any or both of the ordinary seat portions 401 and 402 illustrated in fig. 6 could also be safety seats.

**[0032]** In order to produce one of the combinations explained above the combining part comprises a first end having mechanical attachment means for attaching to a side of an individual swing seat. The combining part is adapted to offer a sitting position for a player, with a front direction of a player sitting in the sitting position being parallel with a swinging direction of said individual swing seat. The combining part comprises also a second end having mechanical attachment means for attaching to a side of a second individual swing seat. In order for this to work, the second individual swing seat must be displaced from said first individual swing seat in a direction perpendicular to said swinging direction.

**[0033]** The attachment between the combining part

and the swing seats at its ends is shown in figs. 3 to 6 to be fixed and rigid. The attachment could also be an easily detachable attachment based on e.g. butterfly nuts, snap-on shapes, locking hooks, interlocking finger joints or the like, so that the combining part could be sold separately to families who wanted to carry it along and transform an ordinary swing with two parallel seats into a family swing according to the invention.

**[0034]** Even if the combining part is fixedly attached, the joints joining it to the swing seats on its sides do not need to be rigid. Fig. 7 illustrates an embodiment of the invention in which a combining part 703 is attached between a safety seat portion 302 and an ordinary seat portion 401 with pliable supports, such as chains 704. Other kinds of non-rigid supports could also be used, including but not being limited to springs, hinges, cords and necks made of flexible material (possibly integrally with the combining part).

**[0035]** A combination seat according to the invention is not necessarily made by using existing swing seats as components. Figs. 8 to 13 and 16 illustrate various integrally made swing seats, most of which can be used as family swings. In fig. 8 there are two safety seat portions 202 at the ends and an ordinary seat portion 201 in the middle. The structure is thus the same as illustrated earlier in fig. 2. In the embodiment of fig. 9 the roles are reversed, so that the combination seat has two ordinary seat portions 201 at the ends and a safety seat portion 202 in the middle. In fig. 10 the combination seat consists of three ordinary seat portions 201 in a row. In the embodiment of fig. 11 there are two safety seat portions 202 side by side and one ordinary seat portion 201 at one end of the combination. In the embodiment of fig. 12 there are two ordinary seat portions 201 side by side and one safety seat portion 202 at one end of the combination. Putting three safety seat portions 202 in a row like in fig. 13 (or putting just two safety seat portions in a row to constitute a "twin swing") is possible, but it does not solve the original problems that were at the starting point of the invention.

**[0036]** Figs. 14 to 16 illustrate embodiments of the invention in which the family swing has only two seat portions. In fig. 14 there are a safety seat portion 301, to the side of which an additional, plank-like part 1403 has been attached with mechanical fasteners 304 to constitute an ordinary seat portion. In fig. 15 there are an ordinary seat portion 401, to the side of which an additional, plank-like part 1503 has been fastened with pliable supports, such as chains 704. The plank-like part 1503 thus constitutes an ordinary seat portion. Fig. 16 illustrates an integrally manufactured seat component with a safety seat portion 202 and an ordinary seat portion 201 displaced from each other in the longitudinal direction of the combination seat thus formed, which longitudinal direction is perpendicular to the swinging direction like in all embodiments described in the previous drawings. Three-chain embodiments like those in figs. 14 to 16 naturally require a different way of attaching vertical supports to

**[0037]** The definition used above for an ordinary seat does not limit the ordinary seat portion to plank-like forms. Fig. 17 illustrates a combination seat according to an embodiment of the invention, in which the ordinary seat portion 201 is a tyre seat attached with cords between two safety seat portions 202. Fig. 17 is also an example of having the sitting heights of the different seat portions differently selected in the combined structure.

**[0038]** Changes to the exemplary embodiments illustrated above are possible without departing from the scope of protection defined in the claims. For example, even if only one kind of a support frame has been illustrated in fig. 2, a playground swing according to the invention may have many other kinds of support frames, like such where each end of the horizontal support beam rests on the top of a vertical A-frame, or such that do not have any horizontal support beam but only two individually standing supports, each one defining one or more attachment points for the pliable supports of the swing seat. As was pointed out above, the number of chains or other pliable supports is not necessarily exactly four for three-player swing seats or three for two-player swing seats. The safety seat portions may have the lower part and the ring part manufactured integrally in one piece, or they can be assembled from a number of parts.

## Claims

1. A swing seat for a playground swing, comprising:
  - a first seat portion (201, 303, 703, 1403, 1503),
  - a first hanging point and
  - a second hanging point;

wherein the first hanging point is located at a distance from said second hanging point in a longitudinal direction (204) of the swing seat, thus defining a swinging direction (205, 206) that is perpendicular to said longitudinal direction (204) of the swing seat;

**characterized in that:**

  - the swing seat comprises a second seat portion (202, 301, 401),
  - both the first (201, 303, 703, 1403, 1503) and the second (202, 301, 401) seat portion are formed to offer a sitting position for a player, with a front direction of a player sitting in the sitting position being parallel with the swinging direction (205, 206), and
  - said second seat portion (202, 301, 401) is displaced from said first seat portion (201, 303, 703, 1403, 1503) in the longitudinal direction (204) of the swing seat.
2. A swing seat according to claim 1, **characterized in that** exactly one of the first (201, 303, 703, 1403, 1503) and second (202, 301, 401) seat portions is a

safety seat portion that comprises a lower part (203) and a ring part (104) supported above said lower part (203).

3. A swing seat according to claim 2, **characterized in that** said lower part (203) has an extending end that extends beyond said second seat portion (202, 301) in the longitudinal direction (204) of the swing seat, and the extending end of said lower part (203) constitutes said first seat portion (201, 303, 703, 1403, 1503).
4. A swing seat according to claim 3, **characterized in that** the swing seat is one integrally manufactured piece, and said lower part (203) is continuous all the way from the safety seat portion (202) to said first seat portion (201).
5. A swing seat according to claim 3, **characterized in that** the extending end of said lower part is fixedly attached to the second seat portion (201) with rigid mechanical fasteners (304).
6. A swing seat according to claim 3, **characterized in that** the extending end of said lower part is fixedly attached to the second seat portion (201) with pliable supports (704).
7. A swing seat according to claim 2, **characterized in that:**
  - the swing seat comprises a third seat portion (302, 402) formed to offer a sitting position for a player, with a front direction of a player sitting in the sitting position being parallel with the swinging direction (205, 206), and
  - said third seat portion (302, 402) is displaced from said first (201, 303, 703) and second (202, 301, 401) seat portions in the longitudinal direction (204) of the swing seat.
8. A swing seat according to claim 7, **characterized in that** the third seat portion (302) is a safety seat portion.
9. A playground swing, comprising:
  - a swing seat with a first seat portion (201, 303, 703, 1403, 1503),
  - a support frame (105, 106),
  - a first vertical support (107) connecting a first hanging point of the swing seat to the support frame, and
  - a second vertical support (107) connecting a second hanging point of the swing seat to the support frame;

wherein the first vertical support (107) is located at

a distance from said second vertical support (107) in a longitudinal direction (204) of the swing seat, thus defining a swinging direction (205, 206) that is perpendicular to said longitudinal direction (204) of the swing seat;

**characterized in that**

- the swing seat comprises a second seat portion (202, 301, 401),
  - both the first (201, 303, 703, 1403, 1503) and the second (202, 301, 401) seat portion are formed to offer a sitting position for a player, with a front direction of a player sitting in the sitting position being parallel with the swinging direction (205, 206), and
  - said second seat portion (202, 301, 401) is displaced from said first seat portion (201, 303, 703, 1403, 1503) in the longitudinal direction (204) of the swing seat.
10. A playground swing according to claim 9, **characterized in that** the swing seat comprises a third seat portion (302, 402) formed to offer a sitting position for a player, with a front direction of a player sitting in the sitting position being parallel with the swinging direction (205, 206).
  11. A playground swing according to claim 10, **characterized in that:**
    - the playground swing comprises four vertical supports (107), each connecting one hanging point of the swing seat to the support frame, and each hanging point being located at a distance from other hanging points in a longitudinal direction (204) of the swing seat, and
    - the first (201, 303, 703), second (202, 301, 401) and third (302, 402) seat portions are located between hanging points so that there is one hanging point on each side of each seat portion.
  12. A playground swing according to claim 11, **characterized in that:**
    - the two seat portions (301, 302, 401, 402) at the extremities of the swing seat are constituted of individual swing seats each having two vertical supports connecting it to the support frame and
    - the middle seat portion is constituted of a combining part (303, 603, 703) that is mechanically attached between said two seat portions at the extremities of the swing seat.
  13. A combining part (303, 603, 703, 1503) for a playground swing, **characterized in that** for turning a playground swing with at least a first individual swing seat (301, 401), into a family swing the combining

part comprises:

- a first end, and
- in said first end mechanical attachment means (304, 704) for attaching to a side of said first individual swing seat (301, 401):

and further **characterized in that** the combining part (303, 603, 703, 1503) is adapted to offer a sitting position for a player, with a front direction of a player sitting in the sitting position being parallel with a swinging direction (205, 206) of said first individual swing seat (301, 401).

14. A combining part according to claim 13, **characterized in that** the combining part (303, 603, 703) comprises a second end and in said second end mechanical attachment means for attaching to a side of a second individual swing seat (302, 402) displaced from said first individual swing seat (301, 401) in a direction perpendicular to said swinging direction.
15. A combining part according to claim 14, **characterized in that** the combining part (303, 703) has a plank-like form that constitutes an ordinary swing seat portion.
16. A combining part according to claim 14, **characterized in that** the combining part (603) has a lower part (601) and a ring part (602) supported above said lower part, the combining part (603) thus constituting a safety seat portion.

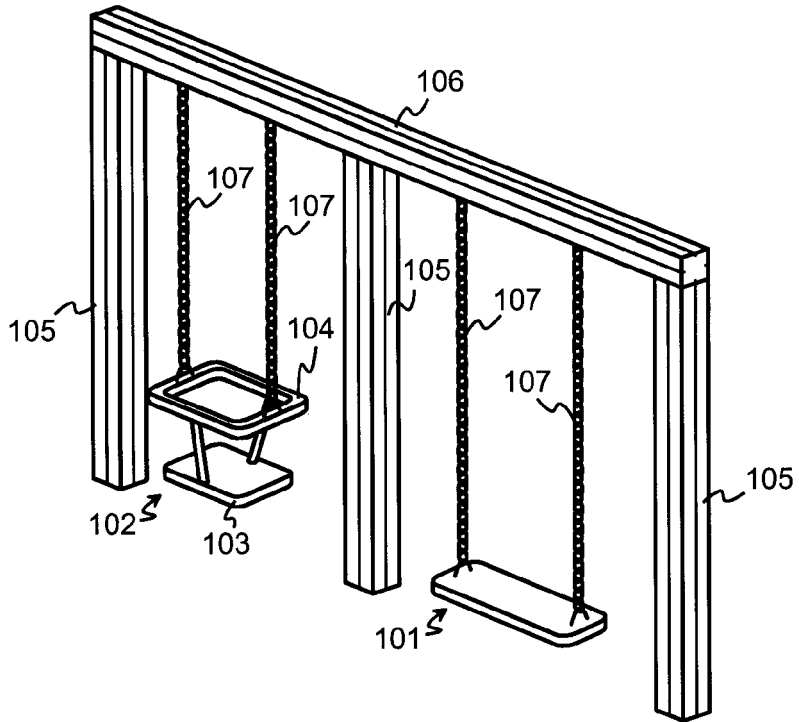

**Fig. 1**  
PRIOR ART

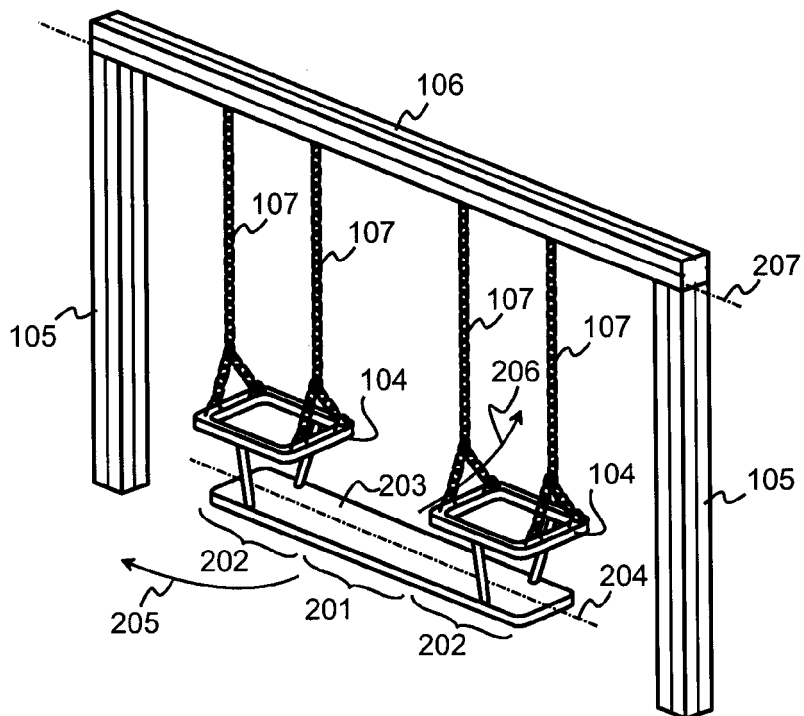

**Fig. 2**

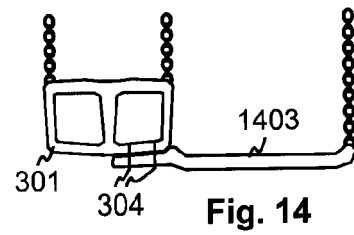
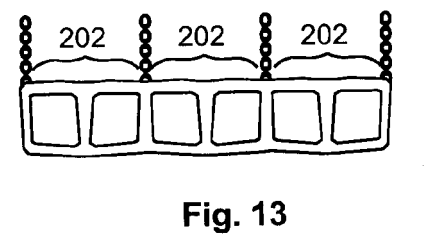
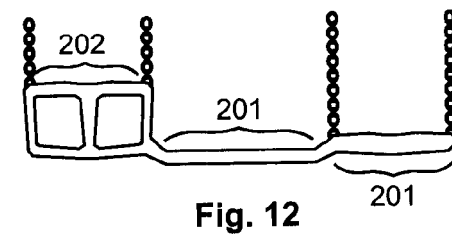
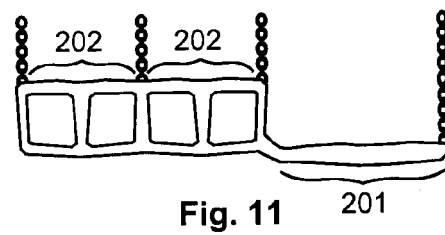
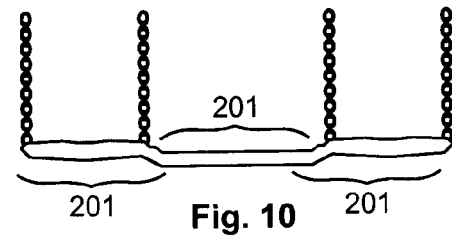
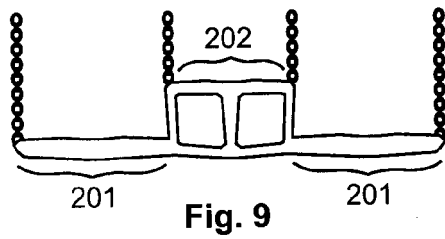
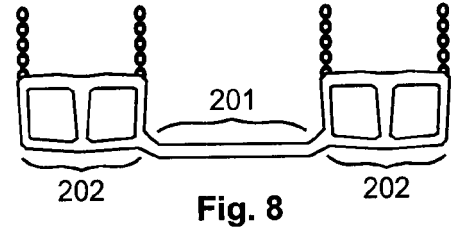
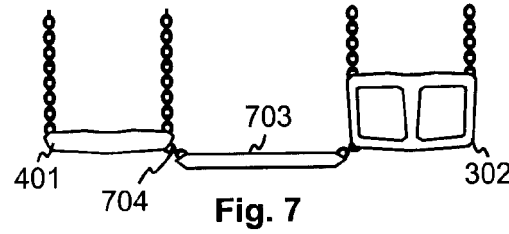
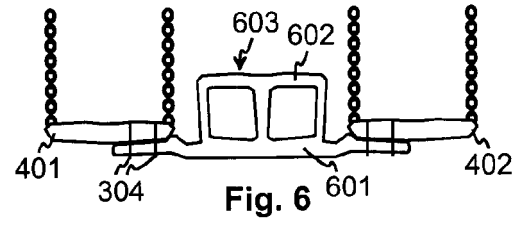
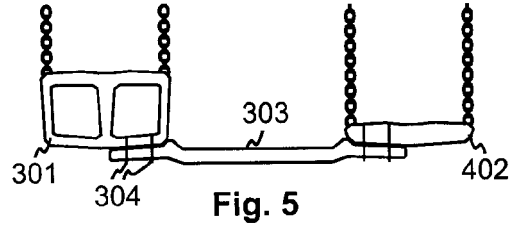
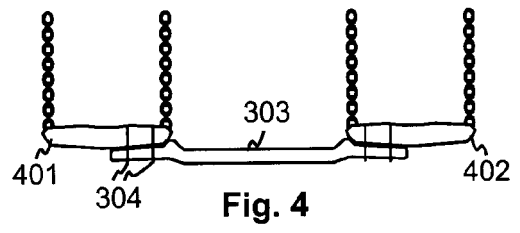
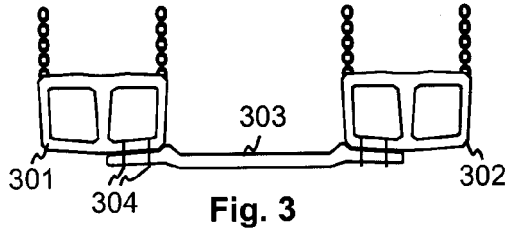

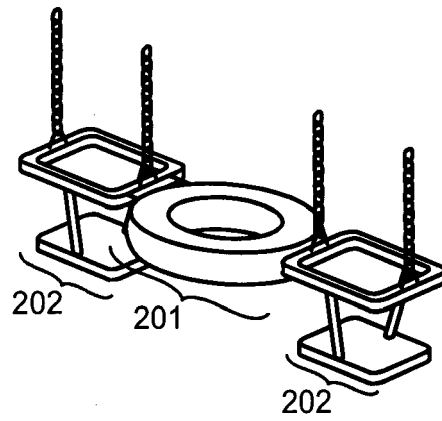
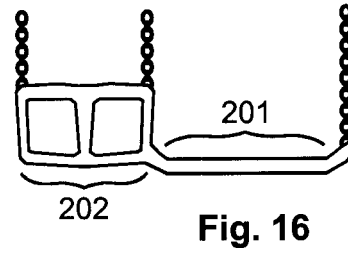
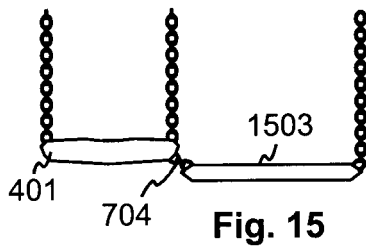

Fig. 17



EUROPEAN SEARCH REPORT

Application Number  
EP 08 17 0543

DOCUMENTS CONSIDERED TO BE RELEVANT			
Category	Citation of document with indication, where appropriate, of relevant passages	Relevant to claim	CLASSIFICATION OF THE APPLICATION (IPC)
X	US 1 460 843 A (BROWN JEREMIAH E) 3 July 1923 (1923-07-03)	1,9-11	INV. A63G9/00
Y	* the whole document *	2-7,16	
X	US 2 539 869 A (SICKLESTEEL GEORGE D) 30 January 1951 (1951-01-30)	1,9	
Y	* the whole document *	3,4	
Y	GB 2 331 022 A (PARKER MICHAEL JOHN [GB]) 12 May 1999 (1999-05-12)	2-4,7,16	
X	FR 440 339 A (M.FERNAND CAUËT) 2 May 1912 (1912-05-02)	13	
Y	* figures *	5,6	
A	US 3 615 119 A (IRWIN ROY L) 26 October 1971 (1971-10-26)	1,9,13	
			TECHNICAL FIELDS SEARCHED (IPC)
			A63G A47D
The present search report has been drawn up for all claims			
Place of search		Date of completion of the search	Examiner
Munich		2 March 2009	Turmo, Robert
CATEGORY OF CITED DOCUMENTS			
X : particularly relevant if taken alone		T : theory or principle underlying the invention	
Y : particularly relevant if combined with another document of the same category		E : earlier patent document, but published on, or after the filing date	
A : technological background		D : document cited in the application	
O : non-written disclosure		L : document cited for other reasons	
P : intermediate document		& : member of the same patent family, corresponding document	

2  
EPO FORM 1503 03.82 (P04C01)

**ANNEX TO THE EUROPEAN SEARCH REPORT  
ON EUROPEAN PATENT APPLICATION NO.**

EP 08 17 0543

This annex lists the patent family members relating to the patent documents cited in the above-mentioned European search report. The members are as contained in the European Patent Office EDP file on  
The European Patent Office is in no way liable for these particulars which are merely given for the purpose of information.

02-03-2009

Patent document cited in search report	Publication date	Patent family member(s)	Publication date
US 1460843	A	03-07-1923	NONE
US 2539869	A	30-01-1951	NONE
GB 2331022	A	12-05-1999	NONE
FR 440339	A		NONE
US 3615119	A	26-10-1971	NONE

EPO FORM P0459

For more details about this annex : see Official Journal of the European Patent Office, No. 12/82

**REFERENCES CITED IN THE DESCRIPTION**

*This list of references cited by the applicant is for the reader's convenience only. It does not form part of the European patent document. Even though great care has been taken in compiling the references, errors or omissions cannot be excluded and the EPO disclaims all liability in this regard.*

**Patent documents cited in the description**

- GB 2195550 A [0006]
- US 3663016 A [0006]