

Nov. 17, 1953

E. J. QUINBY ET AL  
TOUCH-RESPONSIVE KEYBOARD

2,659,533

Filed Jan. 27, 1951

2 Sheets-Sheet 1

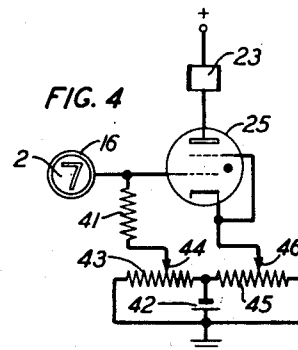
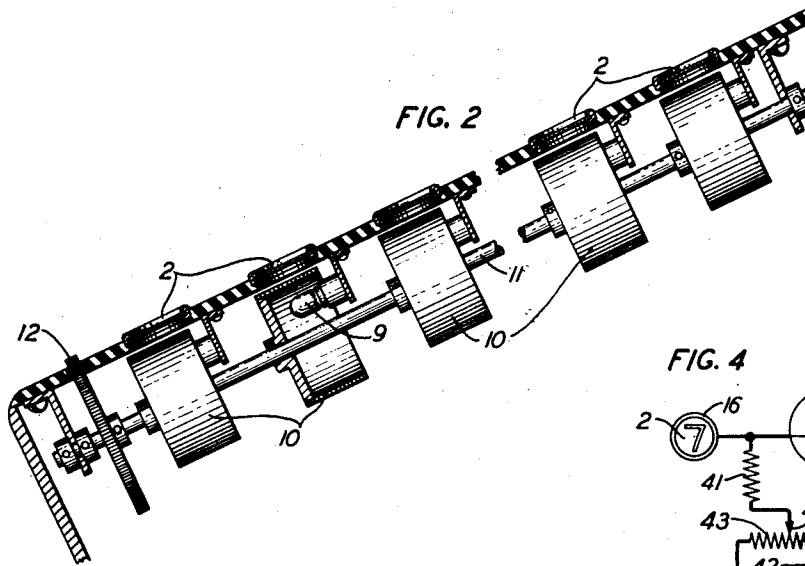
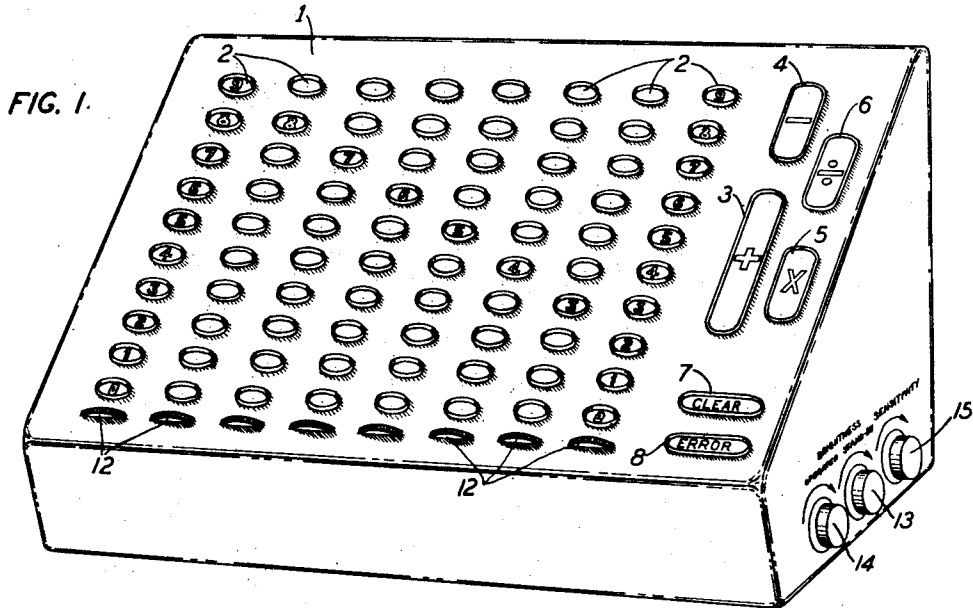

INVENTORS: EDWIN J. QUINBY  
WALTER S. OLIWA

BY

*George H. Lorch*

ATTORNEY

Nov. 17, 1953

E. J. QUINBY ET AL

2,659,533

TOUCH-RESPONSIVE KEYBOARD

Filed Jan. 27, 1951

2 Sheets-Sheet 2

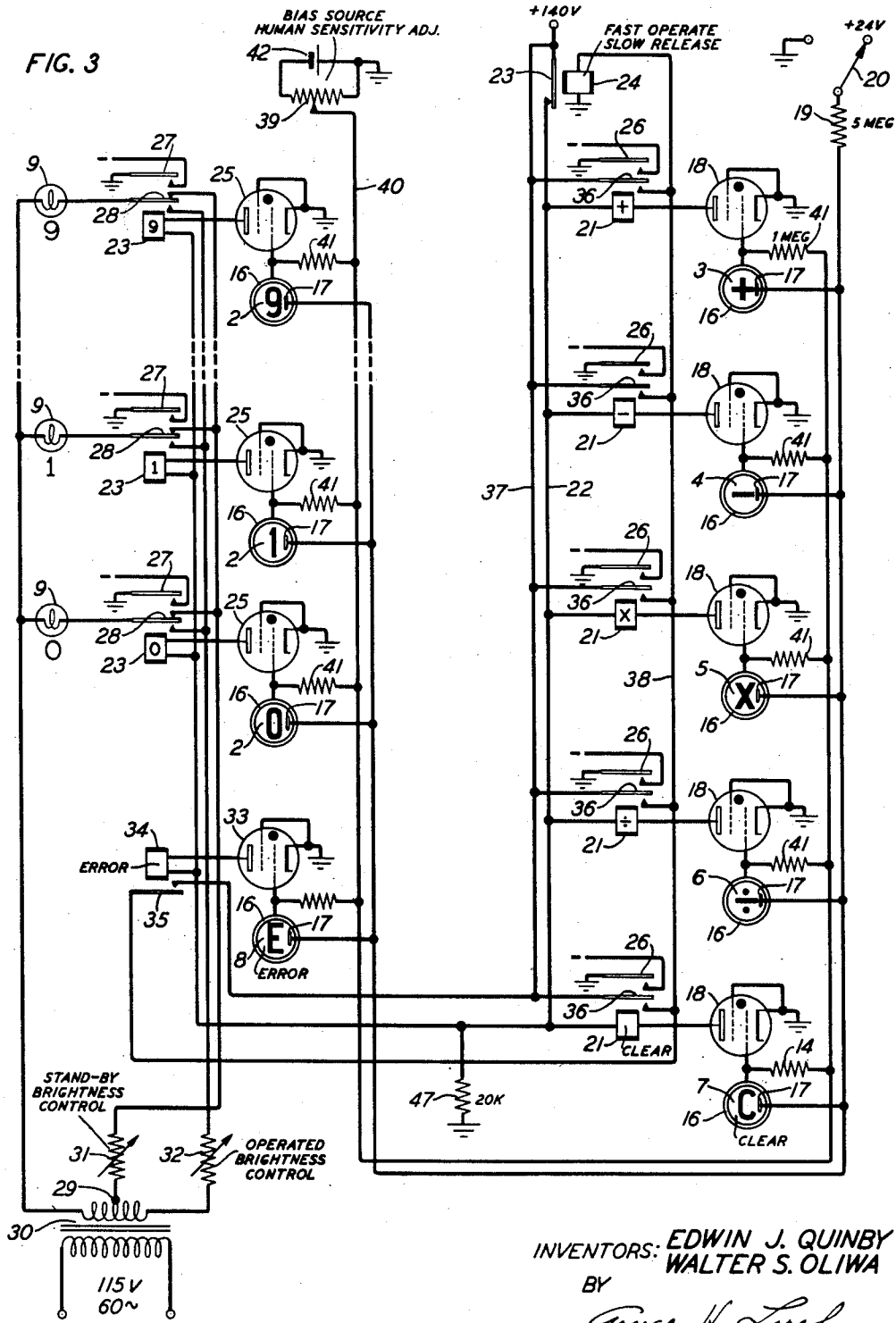

INVENTORS: EDWIN J. QUINBY  
WALTER S. OLIWA  
BY  
*George H. Lorch*  
ATTORNEY

# UNITED STATES PATENT OFFICE

2,659,533

## TOUCH-RESPONSIVE KEYBOARD

Edwin J. Quinby, New York, N. Y., and Walter S. Oliwa, Orange, N. J., assignors to Monroe Calculating Machine Company, Orange, N. J., a corporation of Delaware

Application January 27, 1951, Serial No. 208,216

8 Claims. (Cl. 235—145)

1

This invention relates to touch responsive key-boards such as are applicable to desk machines of the type including calculating machines, typewriters, elevator controls, and other key-operated equipment, either directly or remotely controlled.

It is an object of our invention to provide a touch responsive keyboard for calculating machines, typewriters, and the like, wherein there is no need to do more than touch the different motionless key-representing areas on a flat surface in order to control and operate the machine.

Another object is to provide control mechanism for a desk machine which is operable in accordance with the selective touching of motionless key-representing zones on a flat surface.

Still another object is to provide electronic equipment responsive to signals derived from a touch-controlled keyboard having stationary key-simulating spots arrayed on a flat surface.

Still another object is to provide translucent key-simulating areas on a substantially flat keyboard and means for varying the intensity of back lighting of such areas. With the accomplishment of this object we are enabled to give greater brilliance to any area which has been touched and thus to indicate a "set-up" of selecting keys before touching an operate key.

Another object is to provide means for varying the color characteristics of the back lighting as applied to motionless keys on a keyboard, or key-simulating panel.

The foregoing and other objects and advantages of our invention will be brought out in more detail in the description to follow. This description is accompanied by drawings in which:

Fig. 1 shows in perspective a conventional keyboard of the type with which this invention is concerned;

Fig. 2 shows a cross sectional elevation view of one strip of motionless keys in association with which there is provided a means for varying the color effects of back lighting of the key areas;

Fig. 3 shows a preferred circuit arrangement whereby responses to the touching of key areas on the keyboard are obtained and made useful in the control of a desk machine; and

Fig. 4 shows a modification of the circuit arrangement of Fig. 3.

The basic idea of a touch responsive keyboard is one wherein the human finger enters into a circuit arrangement when touching one of the key-simulating areas of the keyboard. The electric current which is thus caused to flow through the circuit is very minute and when carried through the human body cannot be felt, and is

2

perfectly harmless. It is, however, capable of controlling an electronic element, such as a Thyatron tube, and thus to trigger the same, causing it to operate a relay for performing any desired function. The key-representing areas of our touch responsive keyboard are each inclusive of one or two embedded conductive terminals. In one form of our apparatus, each key-simulating area is provided with only a single circuit terminal. The control grid of a Thyatron tube is connected to this terminal and is normally biased by a resistive connection to a negative potential source terminal for normally holding the grid more negative than the cathode. Then, by touching the key, the grid potential is brought to a triggering point so that the tube fires. In other forms of our equipment each key-representing area is inclusive of two embedded circuit terminals so that when it is touched the human finger alone bridges these two terminals and completes the circuit. This form of apparatus has been found to be much more sensitive than the one first described. It lends itself also to sensitivity control which we provide for compensation purposes where the ohmic resistance of the human skin varies with different individuals and with climatic conditions.

Referring now to Fig. 1, we show therein a conventional calculating machine keyboard 1 having digital rows of keys 2 which are labeled 0 to 9 inclusive. In a calculating machine particularly, it is also necessary to provide operating keys, such as an add key 3, a subtract key 4, a multiplication key 5, and a division key 6. A clear key 7 is provided for clearing the machine after performing any desired computation. An error key 8 is used to restore any erroneous set-up on the keyboard before touching any of the operate keys.

Referring to Fig. 2, the cross-sectional view therein represents a portion of one digital strip of motionless keys 2. Underlying them are mounted individual lamp bulbs 9. Surrounding each of the lamp bulbs is a cylindrical member 10 of translucent material, preferably for use as a color filter. Each of these cylinders is mounted for rotation on a shaft 11. Different groups of such members having a common shaft 11 are provided for the different digital orders of the keys in the computing machine so the shaft 11 is aligned and parallel with the digital key strips.

We also provide a knurled adjusting disk 12, one perimeter portion of which is exposed above the plane of the keyboard so that the color filtering cylinders may be rotated as a digital order group to bring any desired one of several possible

color selections between the lamps 9 and the translucent keys 2. The variation in color may be within any desired range in the visible spectrum. The advantage of having a common control for the color effects with respect to each digital order of the keys is that if it is desired to separate two adjacent columns of keys by an indication of the decimal point location, these two columns can be distinguishably colored.

We have found it to be of advantage to provide normally dim lighting of all the keys of the keyboard until any of them are touched; then, as part of the touch-responsive action, the light intensity is automatically increased under the keys that have been touched. We also provide means for adjustable control of the light intensity levels both under stand-by conditions and after the keys have been touched. Thus rheostats are included in the lighting circuits for our touch-responsive keyboard so that the two levels of brilliance may be controlled independently to meet varying conditions of incident lighting and to satisfy the demands of the individual operator. For this purpose, a control knob 13 on the side of the machine is used to adjust the initial brightness for stand-by lighting conditions, and another control knob 14 is used to adjust the full brilliance of those keys that are touched.

The sensitivity adjustment which was mentioned above preferably utilizes a control knob 15. The circuit arrangements which are controlled by these knobs 13, 14 and 15 will be set forth in the ensuing description of Fig. 3.

In the circuit diagram of Fig. 3 we show some of the key positions 2 of a single digital order in a conventional computing machine. We also indicate several operating keys 3 to 3 inclusive as in Fig. 1. Each of these keys is constituted as one or two exposed conductor terminals embedded in a key-representing portion of an insulated plate or table 1. The latter is preferably composed of translucent plastic.

In the embodiment of Fig. 3, each of the keys 2 to 8 inclusive comprises an annular metal terminal 16 and another metal terminal 17. The size and shape of terminal 17 is not critical. In a preferred form, the character designations may be of metal supported by the insulating material within the circular area of each key. Each metallic character must itself be a circuit terminal 17 in that case and be exposed to be touched at the same time as the ring 16. The terminal 16 is connected to the first grid of a gaseous discharge tube 18 while terminal 17 is connected to a bus line leading through resistor 19 and thence to a manually controlled switch 23 having two positions. In one of these positions, connection may be made from ground through the resistor 19 to all of the key terminals 17. In the other position of the switch 20 it is arranged to supply a positive voltage of, say, 24 volts D. C., to each of the terminals 17. The voltage of this source is not critical, but may, if desired, be as high as 100 volts.

Each of the gaseous discharge tubes 18, 25 and 33 is preferably of the tetrode type. That is to say, it has an anode, a cathode and two grids, the first grid being a control grid and the second grid being a shield grid in connection with the cathode.

Each of the anodes in the tubes 18 is individually connected through the winding of a relay 21 and thence to a bus line 22 leading through contacts 23 of a circuit opening relay 24. This

relay is designed for fast-operate-and-slow release action. A D. C. potential of, say, 140 volts is supplied through bus 22 to each of the windings of relays 21 and thence to the anodes of the respective gaseous tubes 18, except when relay 24 is operated to open its contacts 23. The cathodes of tubes 18, 25 and 33 are grounded, as is the negative terminal of the 140 volt source.

The bus 22 is extended to the windings of relays 23 and 34 as well as relays 21. The keys 2 control gaseous tubes 25 individually. When any of these tubes is triggered the relay 23 or 34 which is in series therewith operates.

There is a relay and gaseous tube circuit corresponding to each of the selecting keys 2 and also corresponding to each of the operate keys 3-8 inclusive. Relays 21 have different control functions to be performed in the operation of a machine. That is to say, they cause a calculating machine, for example, to be electrically controlled the same as though its conventional keyboard were to be manipulated. Accordingly, each of these relays has circuit closing contacts 26 for applying ground potential to some one or another of the various control circuits by which a computing machine may be electromagnetically operated.

Since the keys 2 have a selecting function to be performed prior to the "operate" function of the keys 3-7 inclusive, it will be understood that circuit closures made by contacts 27 of the operated relays 23 will be used to carry out any of the normal selecting functions of a calculating machine keyboard. Thus, the grounded relay contacts 27 when closed against their respective front contacts will serve to carry out these key-selecting functions, and to operate any electromagnetic devices that may be provided in the calculator.

Operatively associated with each of the relays 23 is one of the indicating lamps 9 that were referred to in the description of Fig. 2. In order to vary the intensity of the lighting in these lamps beneath the key spot areas, transfer contacts 28 on relays 23 are used. Each of these transfer contacts, when resting against its associated back contact, causes a potential to be fed to the connected lamp 9 from an intermediate tap 29 on the secondary winding of a transformer 30. The primary winding of this transformer is supplied from any suitable alternating current source, say 115 volts and 60 cycles. This tap 29 is connected to the said back contacts of relays 23 through a rheostat 31 which is adjustable by means of the control knob 13, as shown in Fig. 1. The front contacts associated with the movable contacts 28 on relays 23 are all connected through another rheostat 32 to an outer terminal on the secondary winding of transformer 30. Thus, the full voltage across this secondary winding may be supplied through the rheostat 32 to the lamps 9 whenever an associated relay 23 is operated. The return circuit common to all of the lamps 9 is connected to the other outer terminal on the secondary of transformer 30.

Operatively associated with the error key terminals 8 is a gaseous tube 33, the connections for which are similar to those of the other tubes. The anode of tube 33 has a connection through the winding of a relay 34 to the bus line 22 and thence through the circuit-breaking contacts 23 on relay 24 to the positive D. C. source (140 v.). Since the error key has no function to perform

other than to restore any erroneously touched keys 2, we have not shown this key as having any functional control circuit leading to the calculating machine proper. In operation, the error key, when touched, will perform its service as follows:

By bridging the two terminals in key 8 the first grid of tube 33 is driven positive, or at least is supplied with ground potential which is sufficient to trigger the tube 33, its cathode being grounded. Therefore, tube 33 operates as a switch to complete a circuit from ground through the winding of relay 34 and thence through the circuit-breaking contacts 23 of relay 24 to the +140 v. terminal of the power supply. Relay 34, upon operating, closes its contacts 35 and supplies an operating potential to one terminal on the winding of relay 24, the other terminal of which is grounded. Operation of relay 24 therefore follows in sequence to the operation of relay 34 and opens the circuit of the latter. At this point, de-ionization of tube 33 takes place and relay 34 releases, opens its contacts 35 and causes relay 24 to be released. Since this is subsequent to the de-ionization of tube 33, the entire system is restored to normal. The correction of any error which was incident to the improper touching of keys 2 also takes place due to the open circuit condition at contacts 23 of relay 24 whence current is no longer supplied to the bus 22. Therefore, any triggered tubes 25 which may have been fired by the keys 2 will also be extinguished.

As a safeguard against the possibility that some one or more of the Thyatron tubes may not be completely deionized by opening their common anode potential supply line 22 and again closing it when relay 24 releases, it is perhaps desirable to connect a bleeder resistor 47 between the line 22 and ground. This resistor could have a value of, say, 20,000 ohms if desired, and would serve to quickly lower the voltage of the line while relay 24 is operated so as to be far below the ignition voltage until contacts 23 of relay 24 are again closed.

The mode of operation of the error key 8 and its associated gaseous tube 33 and relay 34 is typical of the operate keys 3-7 inclusive when any of the latter are touched. These keys, as has already been explained, serve to control the conventional electromagnetic equipment of a calculating machine. It is necessary, however, when any of the conventional operations are performed to restore the keys of the keyboard. In this case, there is no mechanical operation to be performed but the lamps 9 must be reduced from their full brightness to their stand-by dimness. So, each of the relays 21 is provided with a movable contact 36 by which a circuit may be closed through the winding of relay 24, thus to remove (by circuit-opening contacts 23) the voltage that was supplied through bus 22 to any of the operated relays, including the selected relay 21 and as many of the relays 23 as may have been operated.

All of the relay contacts 36 are connected in the same manner and in parallel between the 140 volt bus line 37 and the common conductor 38 leading to the winding of relay 24. Relay 24 therefore responds equally well and in the same manner to the prior operation of any of the relays 21 or 34. In other words, after any of these relay operations, all of the fired gaseous tubes are extinguished, the positive voltage having been removed from their anodes.

We have found that there is a need in a device of this type for adjusting the normal bias on the

grids of the gaseous tubes to meet different climatic conditions as well as those of the variation in the ohmic resistance of the human flesh or skin when electrically bridging the terminals of the keys. We therefore supply a sensitivity adjustment in the form of a rheostat 39, the movable contact of which is connected to a bus line 40 and thence through separate grid resistors 41 to each of the No. 1 grids in the gaseous tubes 18, 25 and 33. The terminals of rheostat 39 are connected, one of them to ground and the other to the negative terminal of a grid biasing source 42. The positive terminal of this source is also grounded. It will be seen that from this arrangement the normal bias applied to the control grids of the gaseous tubes may be adjusted to any suitable value between ground potential and the negative potential of source 42. Thus, variations of the human sensitivity adjustment may be made readily, using the control knob 15 for this adjustment. It will be seen also that this adjustment is supplemental to and cooperative with the adjustment of bias on the insulated key terminals 17 as obtained by transfer of switch contact 20 from a ground connection to a +24 volt connection, or vice versa.

The circuit arrangement shown in Fig. 4 represents a modification of the invention. The touch-responsive keys 2 are such that each one has but a single electric circuit terminal which is connected to the control grid of a gaseous discharge tube 25 to be triggered.

The conductivity to ground through the human body is relied upon for driving the control grid in tube 25 sufficiently positive to cause the tube to be fired. In order to produce this effect dependably a two-fold biasing adjustment is desirable.

The cathode of tube 25 in this embodiment is normally maintained at a potential which is suitably adjusted between two values the positive limit of which is ground potential and the negative limit of which is the negative voltage of the biasing source 42. The movable tap on rheostat 45 serves this purpose.

The control grid of tube 25 is also maintained at some potential which is negative with respect to the cathode but which is sufficiently close to the threshold of the firing potential so that the tube 25 can be rendered controllable upon touching the key 2. The necessary adjustment is readily made by means of a rheostat 43 having a movable tap 44. This tap is connected through a grid resistor 41 to the control grid of tube 25 and also to the metallic terminal 16 of key 2.

When the taps 44 and 46 are properly adjusted on their respective rheostats 43 and 45 it has been found that the circuit arrangement of Fig. 4 provides an operating component for the touch-responsive keyboard which is not only dependable, but also economical to manufacture. This embodiment also has the advantage that there is no need for a second terminal in each key, and therefore the entire area within a ring-like terminal (to be touched) is made available for back lighting and for displaying a designating character.

Other modifications of the invention may also be made by those skilled in the art but without departing from the spirit and scope of the invention itself. Furthermore, it will be apparent that our improved touch-responsive keyboard is capable of adaptation to most of the requirements of conventional keyboards and may serve to selectively control and operate any of a wide

range of utilization devices and different types thereof.

We claim:

1. A keyset comprising a translucent table of insulating material, conductor terminals exposed on the front side of said table and placed according to keys of a conventional keyset, gaseous discharge tubes each fired by a finger touch on a respective one of said terminals, relays operated, each on firing of said tube lamps each arranged and adapted to illuminate a different small area surrounding one of said conductor terminals, a "stand-by voltage" source for lighting said lamps dimly, an "indicating voltage" source for lighting selected ones of said lamps with additional brilliance in response to the operation of corresponding ones of said relays, and adjustable rheostats in the circuits of said lamps whereby the intensities of illumination are regulable both under "stand-by" and "indicating" conditions.

2. In a keyboard of the class described, an insulating table having exposed contacts mounted thereon in a key-simulating array, a plurality of gaseous discharge tubes for selective control of utilization devices, each tube having electrodes for space path conduction and a control electrode to produce such conduction, an electrical connection between each said control electrode and a corresponding contact in said array, operating and biasing potential sources suitably connected to the electrodes of each of said tubes for maintenance of the same in one of two stable states, a relay connected to each tube and energized when the latter is in a conducting state and control circuits for selective application of ground potential to desired ones of said control electrodes, each of said control circuits being closeable through the flesh of an operator when touching one of said contacts.

3. In a touch responsive keyboard, the combination of a plurality of conductor terminals arranged as keys, a gaseous discharge tube for each terminal having an anode and a grid means for normally maintaining the grids of said tubes at a potential adapted to cut off the tube, each said grid being connected to a said terminal to effect firing of its tube on contact of a finger with the terminal, a relay connected to the anode of each tube and operated on firing of the latter, means to illuminate each said terminal dimly, means controlled by each relay to increase the brilliance of the illumination of the associated terminal on operation thereof, and utilization means controlled by the operation of said relays.

4. In a touch responsive keyboard, the combination of a plurality of conductor terminal pairs arranged as keys, each pair being adapted for bridging by a finger, a plurality of gaseous discharge tubes normally biased beyond cutoff, but each fired on bridging of the associated terminals, means for so biasing said tubes, said means being by-passed by the bridged terminals a relay in circuit with each tube and operated on firing of the latter, means for normally illuminating each terminal pair dimly, means controlled by each relay for increasing the brilliance of the illumination on its terminals, and utilization means controlled by each relay.

5. In a touch responsive keyboard, the com-

ination of a plurality of conductor terminal pairs arranged as keys, each pair being adapted for bridging by a finger, a plurality of gaseous discharge tubes normally biased beyond cutoff, but each fired on bridging of the associated terminals, means for so biasing said tubes, said means being by-passed by the bridged terminals means for adjusting the bias on the tubes to compensate for differences in conductivity of human fingers, a relay in circuit with each tube and operated on firing of the latter, means for normally illuminating each terminal pair dimly, means controlled by each relay for increasing the brilliance of the illumination on its terminals, and utilization means controlled by each relay.

6. The combination according to claim 3 and including rheostat means for adjusting the bias on the tubes to compensate for differences in conductivity of the human body.

7. The combination according to claim 6 wherein the means for illuminating the terminals dimly and the means for increasing the brilliance of the illumination include a lamp for each terminal, a first circuit common to all of the lamps and effective to illuminate each lamp dimly when the associated relay is de-energized, a second circuit common to all of the lamps and effective to illuminate each lamp more brightly when the associated relay is energized and an adjustable rheostat in each said circuit to control the brilliance of the lamps under both conditions.

8. The combination according to claim 5 wherein the means for illuminating the terminals dimly and the means for increasing the brilliance of the illumination include a lamp for each terminal, a first circuit common to all of the lamps and effective to illuminate each lamp dimly when the associated relay is de-energized, a second circuit common to all of the lamps and effective to illuminate each lamp more brightly when the associated relay is energized and an adjustable rheostat in each said circuit to control the brilliance of the lamps under both conditions.

EDWIN J. QUINBY.  
WALTER S. OLIWA.

References Cited in the file of this patent  
UNITED STATES PATENTS

Number	Name	Date
1,084,667	Tallmadge	Jan. 20, 1914
1,311,384	Drew	July 29, 1919
2,047,665	Beggs	July 14, 1936
2,186,325	Dome	Jan. 9, 1940
2,188,159	Rockwood	Jan. 23, 1940
2,202,197	Ewertz	May 28, 1940
2,342,753	Pearson et al.	Feb. 29, 1944
2,357,371	Wolfner	Sept. 5, 1944
2,331,757	Jones	Aug. 7, 1945
2,431,429	Sepavich	Nov. 25, 1947
2,432,527	Lang	Dec. 16, 1947
2,446,719	Ray	Aug. 11, 1948
2,476,257	Hoff	July 12, 1949
2,482,943	Sepavich	Sept. 27, 1949
2,525,769	Bruns	Oct. 17, 1950
2,528,394	Sharpless et al.	Oct. 31, 1950
FOREIGN PATENTS		
Number	Country	Date
426,279	Great Britain	Apr. 1, 1935
483,437	Germany	Oct. 4, 1929