

(No Model.)

F. W. McARDLE.
MOLDER OR FORMER.

No. 523,228.

Patented July 17, 1894.

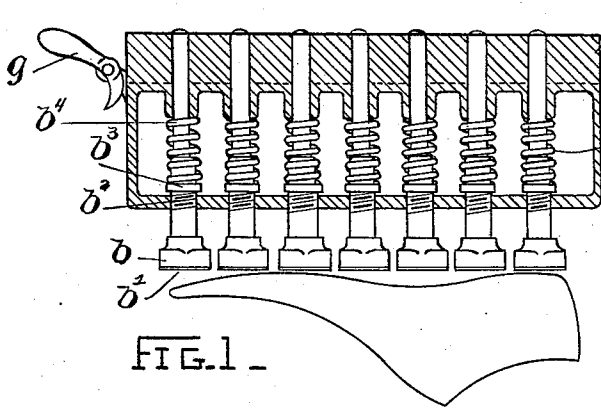

FIG. 1.

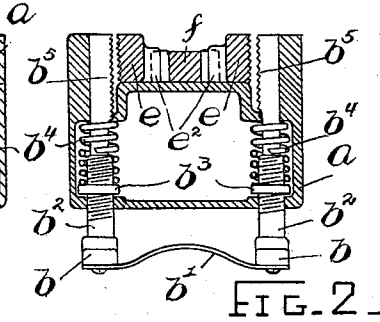

FIG. 2.

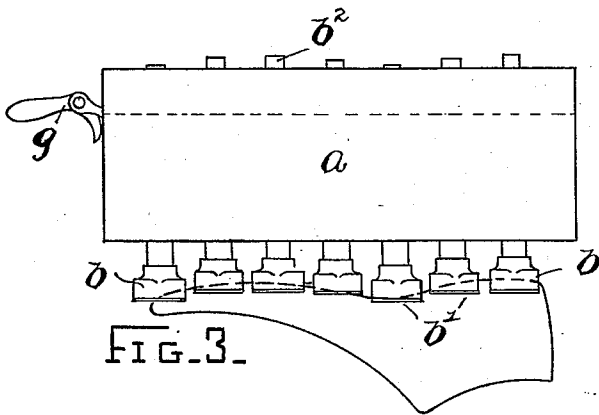

FIG. 3.

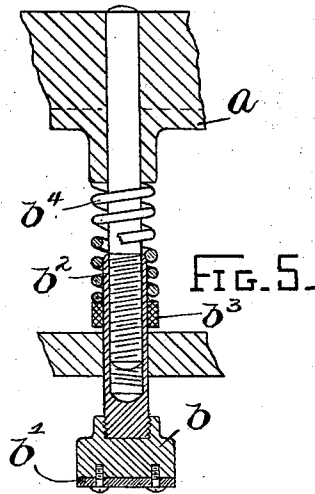

FIG. 5.

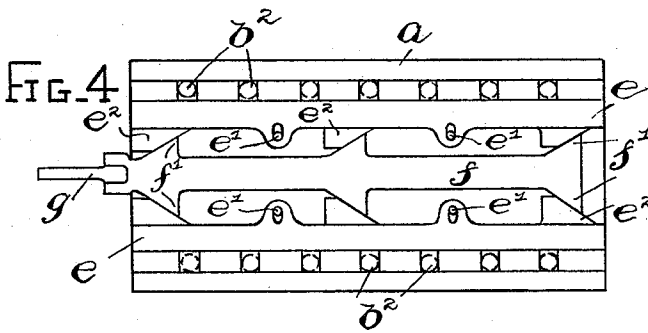

FIG. 4.

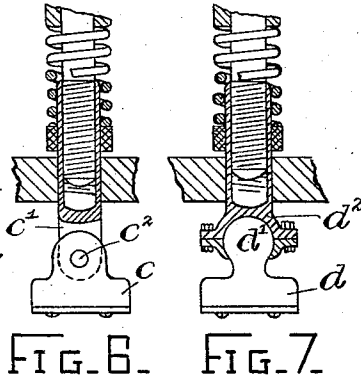

FIG. 6.

FIG. 7.

WITNESSES:

Barker Davis,
H. A. Hall.

INVENTOR:

F. W. McArdle
by
Wright, Brown & Crossley,
Attys.

UNITED STATES PATENT OFFICE.

FRED W. McARDLE, OF BOSTON, MASSACHUSETTS, ASSIGNOR OF TWO-THIRDS TO EDWARD C. JUDD, OF SAME PLACE, AND ABNER C. PAUL, OF LYNN, MASSACHUSETTS.

MOLDER OR FORMER.

SPECIFICATION forming part of Letters Patent No. 523,228, dated July 17, 1894.

Application filed October 30, 1893. Serial No. 489,535. (No model.)

To all whom it may concern:

Be it known that I, FRED W. McARDLE, of Boston, in the county of Suffolk and State of Massachusetts, have invented certain new and useful Improvements in Molders or Formers, of which the following is a specification.

This invention relates to an improved molder or former, which may be adapted to various uses, as, for instance, sole-laying in boot and shoe manufacture, shaping or blocking hats, and applying strips to the skeleton of a boat.

The object of the present invention is to provide a new and improved adjustable locking former or molder which is susceptible of being adjusted into varying positions and locked in this position to make it rigid for increase of pressure upon the object acted on.

To accomplish this object the invention consists in the features of construction and the combination or arrangement of devices hereinafter described and claimed, reference being made to the accompanying drawings, in which—

Figure 1 shows a device adapted for sole-laying. Fig. 2 shows a cross-section of the same. Fig. 3 shows a side elevation. Fig. 4 shows a top plan view. Fig. 5 shows a sectional detail, on an enlarged scale. Figs. 6 and 7 show similar views to Fig. 5 of modifications.

The same letters of reference indicate the same parts in all the figures.

Referring first to Figs. 1 to 7, the letter *a* designates a body or holder, with which the former-sections have a sliding engagement. The former-sections are arranged in a row extending lengthwise of the holder, and each comprises a pair of heads *b* at opposite sides of the holder and supporting a band *b'*, of metal or any other suitable material, and having shanks *b²* extending up through the box and having a sliding engagement therewith. Each shank is preferably composed of two parts, one screwing into the other, and carries a nut *b³* within the box, and a spiral spring *b⁴* bearing at one end against said nut and at the other against the box, and thus tending to press the shank downward. The head *b* may be fixedly connected with the shank by screwing it thereto, as shown in Fig. 5; or it may be pivotally connected therewith, as

shown in Fig. 6, where a head *c* has an ear, which engages a bifurcation *c'* of the shank and is jointed thereto by a pivot-pin *c²*; or, as shown in Fig. 7, a head *d*, formed with a ball *d'*, may be employed in connection with a shank having a socket *d²* to receive said ball, forming a ball-and-socket joint.

A sufficient number of former-sections of the above description are mounted in the holder *a*, and in their normal adjustment all the bands *b'* are in the same plane, as shown in Fig. 1. When the former is pressed upon the work, the sections yield and conform to the contour of the work, each being independently supported. I simultaneously lock all the sections in their different positions of adjustment so that after said sections have yielded and assumed the desired shape they are locked in this position for the purpose of increasing the pressure upon the object. To accomplish this object I provide the following means: Each shank *b²* has its inner side notched or serrated, as shown at *b⁵*, and a pair of correspondingly notched or serrated bars *e* are supported on the upper side of the box *a*, and by lateral movement may be caused to simultaneously engage all the shanks. They are confined by pins *e'*, fastened in the top of the box and engaging slots in the bars. Each bar is formed with inwardly-projecting inclined lugs *e²*, and a longitudinally-movable bar *f*, lying between the bars *e*, is formed with correspondingly-inclined lugs *f'*, engaging said lugs *e²*, whereby longitudinal movement of the said bar *f* produces lateral movement of the bars *e*. The said bar *f* is moved longitudinally by means of a lever *g*, pivoted to it and bearing against the end of the box *a*.

In each of the described constructions, there are a series of independent yieldingly-supported sections, which are adapted to conform flexible pieces or parts to molds or supports of various shapes.

In the construction shown in Figs. 1, 2, 3 and 4, the sections are adapted to be locked in the positions they assume when conformed to the mold or support, this being desirable when the pressure is to be continued for any considerable length of time, as while the flexible piece (for example, a shoe sole) is receiving permanent form by the conjoint action of

the sections and the support against which the flexible piece is pressed.

Having thus described my invention, what I claim as new, and desire to secure by Letters Patent, is—

1. A former or molder, consisting of a frame or holder, a series of yielding former sections adjustable to varying positions, and locking devices for locking the said yielding former sections in their adjusted position to render them rigid for increasing pressure upon the object acted on.

2. The combination in a former or molder, of a frame or holder, a series of yielding former sections adjustable to varying positions, and a locking device which simultaneously engages all of the yielding former sections to hold them rigid in their adjusted positions for increasing pressure upon the object acted on.

3. A molder or former, composed of a number of independent yieldingly-supported sections, and a movable locking-bar having means for engagement with all said sections.

4. A molder or former, composed of a number of independent yieldingly-supported sections, a laterally-movable locking-bar having means for engagement with all said sections, and means for moving said bar into engagement with the sections.

5. A molder or former, composed of a number of independent yieldingly-supported sections, a laterally-movable locking-bar having means for engagement with all said sections and having an incline, and a longitudinally-movable actuating-bar having a corresponding incline.

6. A molder or former, composed of a number of independent yieldingly-supported sections having shanks adapted to slide in a suitable holder or support and each having one side formed for engagement with locking

means, a laterally-movable locking-bar formed for engagement with said shanks, and means for actuating said bar.

7. A molder or former, consisting of a plurality of independent yieldingly supported mold-sections having shanks which slidingly engage a support or holder and are connected with said mold-sections by ball-and-socket joints, and locking devices which engage and hold the shanks in varying positions of adjustment.

8. A molder or former, consisting of a frame or holder, a plurality of independent yieldingly supported mold-sections having shanks slidable in the frame or holder and connected with said mold-sections by ball-and-socket joints, and locking devices which simultaneously engage all the shanks and hold them rigidly in position to increase pressure upon the object acted on.

9. A molder or former, consisting of a frame or holder, a plurality of yieldingspring-pressed former-sections having lengthwise extensible shanks, and locking devices for locking the former sections in varying positions of adjustment.

10. A molder or former, consisting of a frame or holder, two rows or sets of oppositely arranged independently yielding former sections adjustable to varying positions, flexible bands connecting the opposite former sections, and locking devices for holding the former sections rigid to increase the pressure upon the object acted on.

In testimony whereof I have signed my name to this specification, in the presence of two subscribing witnesses, this 25th day of October, A. D. 1893.

FRED W. McARDLE.

Witnesses:

C. F. BROWN,
F. PARKER DAVIS.