

1 577 949

- (21) Application No. 25042/76
- (22) Filed 17 Jun. 1976
- (23) Complete Specification Filed 24 May 1977
- (24) Complete Specification Published 29 Oct. 1980
- (51) INT. CL.<sup>3</sup> A45C 11/00
- (52) Index at Acceptance  
A4G 3
- (72) Inventor: HEDLEY SILMON BRYANT



(54) POT HOLDER

(71) We, MARDON, SON & HALL LIMITED, a British Company of Caxton House, Redcliffe Way, Bristol BS99 7JR do hereby declare the invention for which we pray a patent may be granted to us, and the method by which it is to be performed, to be particularly described in and by the following statement:-

This invention relates to a holder for a plant pot and more particularly to a disposable holder made from a foldable blank of stiff material, e.g. cartonboard or corrugated board. The invention also relates to the blank provided with its fold lines.

One object of the invention is to provide a pot holder which can be collapsed flat for storage or transmission to a customer and which, when erected to receive a plant in a pot, provides some protection for the plant from physical damage.

According to the invention there is provided a holder for a plant pot formed from a foldable blank of stiff material and comprising a collar which, in use, encircles the pot and a shield which extends from the collar and comprises a central panel flanked by wing panels and in use partly surrounds a plant in the pot.

By way of example the invention will now be described with reference to the accompanying drawings of which,

Figure 1 shows a flat blank for erection into a pot holder,

Figure 2 shows the blank in a folded collapsed condition, and

Figure 3 is a perspective view of the erected holder holding a pot shown in the outline in the chain line.

Referring to Figure 1, a blank of cartonboard is provided with fold lines shown in chain line. The blank is generally T-shaped having a shank A and a pair of opposing arms B. A cut 10 extends across the middle portion of the arms B of the T-shaped blank and generally at right angles to the shank A.

The blank comprises a series of panels 11-17 for forming a collar of which the middle panels 13-15 are shorter than the panels 11,12 and 16,17, and three further panels 18-20 for forming a shield which terminate at one end in the cut 10. Panel 19 has a push-in tab 21 to provide a finger hole.

The collar panels 12-16 taper in the direction away from the shield panels 18-20 so that in the erected holder the collar tapers downwards to hold a similarly tapered pot. The shield panels 18-20 are also tapered but in their case to provide a shield which diverges upwards away from the collar panels.

The flat blank of Figure 1 may be erected in the following manner. The blank is conveyed past a pair of overhead adhesive applicators which apply adhesives to the upper portions of the collar end panels 11,17 which lie above a theoretical extension of cut 10, the adhesive being applied to the reverse face of the blank to that shown in Figure 1.

Panels 11,12 are folded over to make reverse facial contact with panels 14/19 and 13/18 respectively, panel 11 becoming bonded by its adhesive panel 19. Panels 16,17 are then folded over to make reverse facial contact with panels 15/20 and panel 11 respectively, panel 17 becoming bonded by its adhesive to panel 11. The resulting folded and glued blank which now forms the holder in its collapsed flat condition, as shown in Figure 2, is ready for storage or for transmission to a customer.

When required for use, the customer exerts inward pressure on the opposing edges 22 of the collar of the collapsed holder, whereupon the foldably connected collar panels 11-17 open out to provide a collar or sleeve of hexagonal form whilst the shield panels 18-20 fold to provide a main shield of trough form which extends upwards from the collar.

5  
10  
15  
20  
25  
30  
35  
40  
45

50  
55  
60  
65  
70  
75  
80  
85  
90

As seen in Figure 3, a round pot 24 having a shouldered rim portion is dropped into the hexagonal collar of the holder so that the pot rim lies immediately adjacent the upper edge of the collar. The rear portion of the pot rim is pushed under the cut bottom edge 23 of the shield. The pot 24 is now held securely in the holder, being prevented from escape downwards by the taper of the collar and from escape upwards by the engagement of its rim under the bottom edge of the shield panels 18-20.

A plant (not shown) which extends upwards from the pot 24 is shielded from physical damage by the central shield panel 19 and its two wing panels 18,20 which partly surround it from the rear. In addition the upper portions of the collar panels 11,12,16,17 which overlap the lower portions of the main shield panels provide an auxiliary shield behind the main shield.

Instead of cartonboard the holder blank may be made from other forms of fibre-board or from a stiff plastics material.

Instead of adhesive the collar panels 11,17 may be secured in position by staples or the like.

#### WHAT WE CLAIM IS :-

1. A holder for a plant pot formed from a foldable blank of stiff material and comprising a collar which, in use, encircles the pot and a shield which extends from the collar and comprises a central panel flanked by wing panels and in use partly surrounds a plant in the pot.

2. A holder according to claim 1, wherein a lower portion of the shield is overlapped by an upward extension of a rear portion of the collar.

3. A holder according to claim 1 or 2 wherein the holder has been erected from a generally T-shaped blank provided with a cut which extends across the middle portion of the arms of the T and generally at right angles to the shank of the T to allow a front portion of the collar to be erected.

4. A holder according to any of claims 1 to 3 wherein the collar tapers downwards to hold a tapered pot.

5. A holder according to any preceding claim, wherein opposing edges of the shield diverge upwards.

6. A holder according to any one of claims 1 to 5, wherein the collar has a hexagonal form and the shield has a trough form.

7. A holder according to any preceding claim, wherein the holder has been automatically erected from a folded collapsed flat condition by inward pressure exerted on opposing edges of the collar.

8. A holder substantially as described herein with reference to Figures 1-3 of the accompanying drawings.

9. A blank for erection into a holder as defined in claim 1, which blank is cut and provided with fold lines substantially as shown in Figure 1 of the accompanying drawings.

B.D.FREEMAN,  
Chartered Patent Agents,  
Agent for the Applicants.

Printed for Her Majesty's Stationery Office,  
by Croydon Printing Company Limited, Croydon, Surrey, 1980.  
Published by The Patent Office, 25 Southampton Buildings,  
London, WC2A 1AY, from which copies may be obtained.

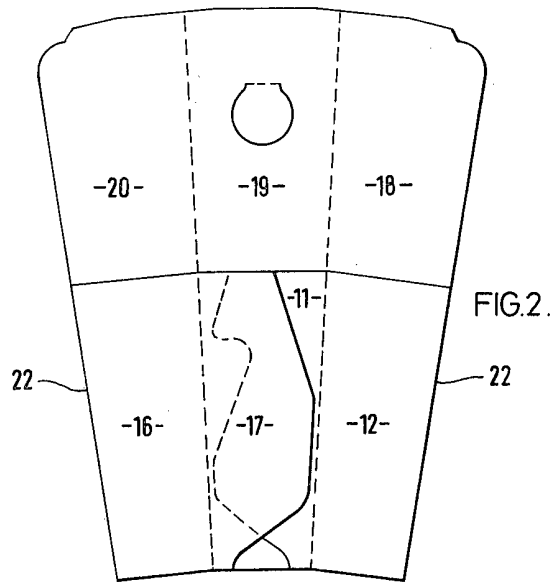
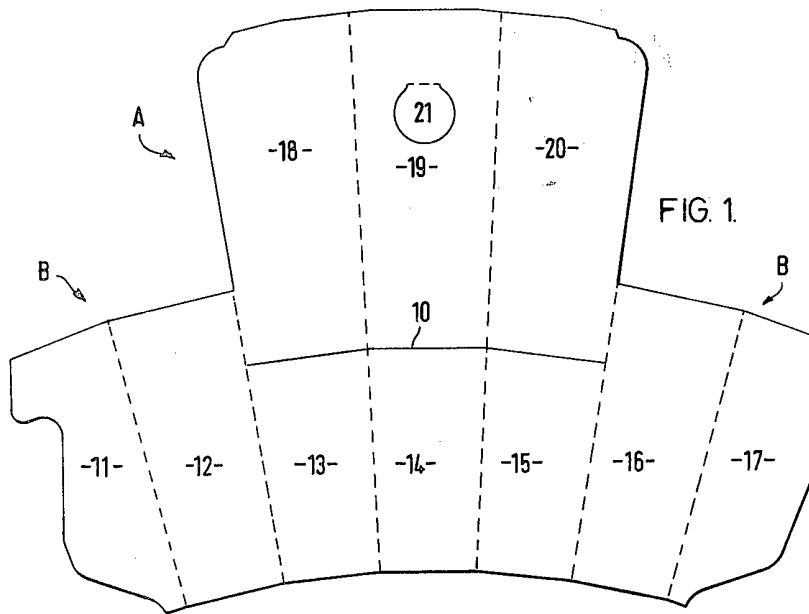

1577949

COMPLETE SPECIFICATION

2 SHEETS

*This drawing is a reproduction of  
the Original on a reduced scale*  
Sheet 2

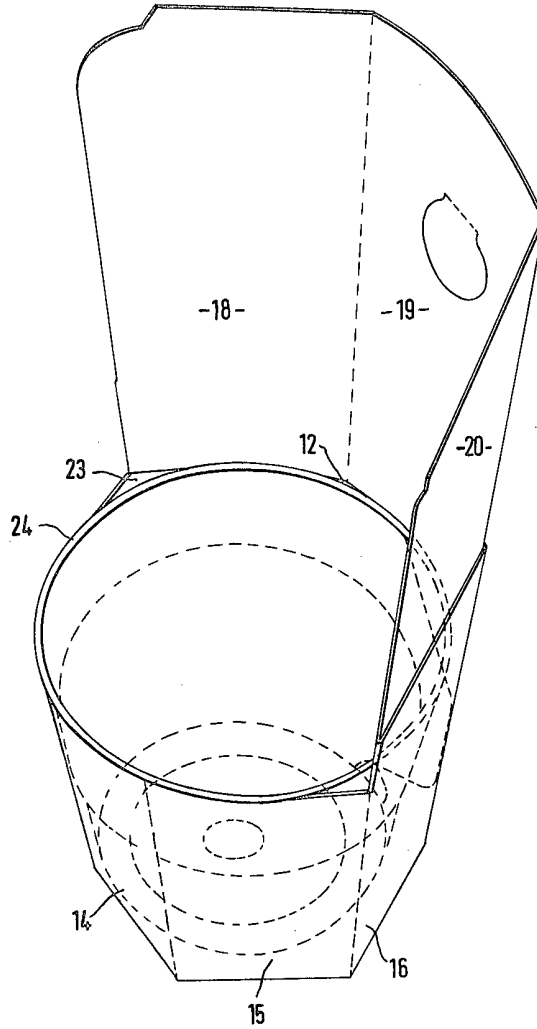

FIG. 3.