



- (51) International Patent Classification:
A01G 1/00 (2006.01) A01G 7/00 (2006.01)
- (21) International Application Number:
PCT/CA2017/000093
- (22) International Filing Date:
21 April 2017 (21.04.2017)
- (25) Filing Language: English
- (26) Publication Language: English
- (30) Priority Data:
2,927,970 22 April 2016 (22.04.2016) CA
- (71) Applicant: 9934294 CANADA INC [CA/CA]; 74, Des Ormes Street West, Saint-Philippe, Quebec J0L 2K0 (CA).
- (72) Inventor: DUMONT, Gilles; 74, Des Ormes Street West, St-Philippe de Laprairie, Quebec J0L 2K0 (CA).
- (74) Agent: FINCHAM, Eric; 1991 Perigny Blvd., Suite 104, Chambly, Quebec J3L 4C3 (CA).

- (81) Designated States (unless otherwise indicated, for every kind of national protection available): AE, AG, AL, AM, AO, AT, AU, AZ, BA, BB, BG, BH, BN, BR, BW, BY, BZ, CA, CH, CL, CN, CO, CR, CU, CZ, DE, DJ, DK, DM, DO, DZ, EC, EE, EG, ES, FI, GB, GD, GE, GH, GM, GT, HN, HR, HU, ID, IL, IN, IR, IS, JP, KE, KG, KH, KN, KP, KR, KW, KZ, LA, LC, LK, LR, LS, LU, LY, MA, MD, ME, MG, MK, MN, MW, MX, MY, MZ, NA, NG, NI, NO, NZ, OM, PA, PE, PG, PH, PL, PT, QA, RO, RS, RU, RW, SA, SC, SD, SE, SG, SK, SL, SM, ST, SV, SY, TH, TJ, TM, TN, TR, TT, TZ, UA, UG, US, UZ, VC, VN, ZA, ZM, ZW.
- (84) Designated States (unless otherwise indicated, for every kind of regional protection available): ARIPO (BW, GH, GM, KE, LR, LS, MW, MZ, NA, RW, SD, SL, ST, SZ, TZ, UG, ZM, ZW), Eurasian (AM, AZ, BY, KG, KZ, RU, TJ, TM), European (AL, AT, BE, BG, CH, CY, CZ, DE, DK, EE, ES, FI, FR, GB, GR, HR, HU, IE, IS, IT, LT, LU, LV, MC, MK, MT, NL, NO, PL, PT, RO, RS, SE, SI, SK, SM, TR), OAPI (BF, BJ, CF, CG, CI, CM, GA, GN, GQ, GW, KM, ML, MR, NE, SN, TD, TG).

(54) Title: HORTICULTURAL APPARATUS

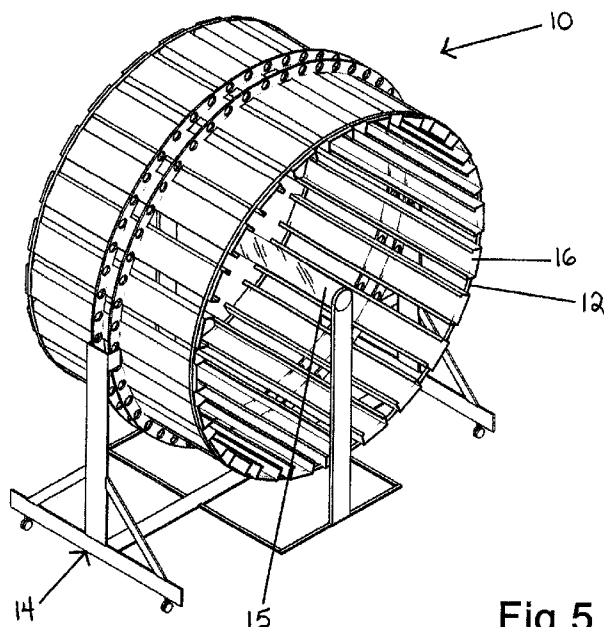

Fig.5

(57) Abstract: A growing apparatus which comprises a rotatable drum (12), a light source (15) situated interiorly of the rotatable drum, a plurality of plant receiving devices extending transversely of the drum and being located interiorly thereof, each of the plant receiving devices (16) including a tray having a plurality of plant receiving receptacles (32) formed therein, each of the plant receiving receptacles having a frustoconical configuration with a narrow end of the frustoconical configuration facing interiorly of the drum towards the light source.

WO 2017/181267 A1

Published:

- with international search report (Art. 21(3))
- before the expiration of the time limit for amending the claims and to be republished in the event of receipt of amendments (Rule 48.2(h))

HORTICULTURAL APPARATUS

FIELD OF THE INVENTION

The present invention relates to a horticultural apparatus and methods pertaining thereto.

BACKGROUND OF THE INVENTION

The use of many different horticultural methods has been practiced for centuries. The growing of plants of many different varieties has been recorded throughout history. In recent times, the practice of agriculture has changed from small family farms to huge plots of land being utilized to grow specific crops. The crop grown in any given area will depend upon the resources available including the type of soil, the weather associated with the particular area and the supply of water.

With the industrialization of agriculture, the industry has grown enormously with certain vegetables or plants growing in one area and shipped substantial distances to the end user. Thus, a vegetable which may be grown year round in South America can be shipped and sold in North America and Europe due to improved transportation resources. While this has greatly increased the variety of plants, vegetables and fruits available in many different countries, there are many people who are critical of this type of agriculture. The reasons include the fact that when a single crop grows on a given plot of land, micro nutrients in the soil are depleted. Also, people are critical of the fact that the transportation of plants to market can lead to substantial pollution and with global warming, this is an increasing problem.

More recently, the use of greenhouses and the like permits growth of normally out of season produces in cooler locales. While this is widely practiced today with certain fruits

and vegetables such as tomatoes and the like, there are many other plants which could be grown locally if there was an efficient way of doing so.

The field of indoor agriculture has been growing enormously as people have realized that this is a more efficient way of growing and can provide locally grown produce. While there are some plants for which this process may not be suitable (such as root vegetables), there is an increasing number of plants which can be grown in this manner.

As the field has developed, there have been proposals in the art for various types of apparatus which can function efficiently. One such apparatus utilizes a rotating drum having a centrally located light source.

SUMMARY OF THE INVENTION

It is an object of the present invention to provide an improved apparatus for the growth of plants.

It is a further object of the present invention to provide a horticultural apparatus which utilizes a rotating drum, the drum having an interior source of light, and a plurality of plant receiving devices mounted on the drum.

According to one aspect of the present invention, there is provided a growing apparatus comprising a rotatable drum, a light source situated interiorly of the rotatable drum, a plurality of plant receiving devices extending transversely of the drum and being located interiorly thereof, the plant receiving devices including a tray having a plurality of plant receiving receptacles formed therein, each of the plant receiving receptacles having a frustoconical configuration with a narrow end of the frustoconical configuration facing interiorly of the drum towards the light source.

Preferably, the apparatus is similar to the apparatus shown in International

Publication WO 2016/058084. In this publication, there is shown an apparatus comprising a rotating drum and which apparatus includes means for feeding the nutrients water to each individual plant according to the specific requirements of that plant. This is accomplished by measuring one or more properties of either the soil or the plant and then calculating the amount of nutrient and/or water needed. In doing this, one provides an extremely efficient arrangement in which there is no waste of resources while maximizing the growth of each plant.

In one embodiment of the present invention, the plants are growing in a tray having a plurality of receptacles formed therein. The tray may form part of a plant receiving device which extends transversely of the rotating drum. Each tray has a plurality of plant receiving receptacles formed therein. Each of the plant receiving receptacles is formed of a frustoconical configuration with the narrow end thereof facing the interior of the drum and the light source. Naturally, it will be understood that not all of the plant receiving receptacles may be of a frustoconical configuration as other configurations for some of the trays may be suitable for different types of plants.

The other end of the frustoconically shaped plant receiving receptacles may be covered with a suitable material. Thus, the trays may be sealed with a film made of cellophane or other suitable materials.

The trays may be designed of different sizes depending upon the plant to be grown. The trays may be refillable and re-used several times.

As previously mentioned, the apparatus may be provided with a system for feeding water and/or nutrients to the individual plants. By feeding the optimal amount to each plant, disposal of material is avoided. The optimal amount may be determined by measuring one

or more properties of the plant and/or the soil and using suitable algorithms, creating a “perfect” level for each plant.

The apparati are preferably stacked to minimize space. The stacked apparati may be movable in forward/reverse directions and lateral directions.

BRIEF DESCRIPTION OF THE DRAWINGS

Having thus generally described the invention, reference will be made to the accompanying drawings illustrating embodiments thereof, in which:

Figure 1 is a schematic top plan view illustrating movement of rows of apparati according to the present invention;

Figure 2 is a schematic top plan view illustrating lateral movement of the apparati;

Figure 3 is a schematic side view of a plurality of apparati interconnected according to an embodiment of the present invention;

Figure 4 is a schematic side view illustrating lateral movement of apparati according to the present invention;

Figure 5 is a perspective view of a single apparatus used in the present invention;

Figure 6 is a perspective view of a tray having plant receiving receptacles formed therein;

Figure 7 is a bottom view of the tray of Figure 6;

Figure 8 is an end view thereof;

Figure 9 is a perspective view illustrating placement of a portion of a tray;

Figure 10 is a view of the tray in position;

Figure 11 is a perspective view illustrating movement of a portion of the trays;

Figure 12 is a perspective view thereof;

Figure 13 is an exploded view thereof;

Figure 14 is a bottom perspective view of a tray having plant receiving receptacles formed therein; and

Figure 15 is a perspective view illustrating the tray of Figure 14 having a sealing film thereon.

DETAILED DESCRIPTION OF THE INVENTION

Referring to the drawings in greater detail and by reference characters thereto, there is illustrated in Figure 5 a horticultural apparatus which is generally designated by reference numeral 10.

Horticultural apparatus 10 is preferably like that shown in International Application PCT/CA2015/000538, the apparatus including a rotating drum 12 which is mounted on any suitable stand 14. Interiorly of rotating drum 12 are a plurality of transversely extending trays 16. The horticultural apparatus will also include a light source 15 as well as a means for supplying moisture and nutrients to plants within transversely extending trays 16.

The present invention can utilize such a horticultural apparatus which is conventionally used interiorly of a building, but stacked to have a plurality of such apparatus mounted on top of each other as illustrated in Figures 1 to 4. In such an arrangement, the apparati may be utilized in a manner so as to occupy the least space. However, the apparati are also movable in a direction as indicated by arrow 18 in Figure 1 and are further movable laterally as indicated by arrow 20 in Figure 2. Thus, the apparati may be left in position during the period of time during which growth is occurring. When it is time to harvest the plants, the apparati may be moved to provide better access to the plants. Thus, the apparati can be moved to a staging area wherein the plants are either directly harvested or

alternatively, according to an embodiment of the present invention, the trays are removed from the apparatus for further processing. New trays may then be inserted as will be discussed hereinbelow.

It will be understood that many different arrangements may be utilized. In one embodiment, the interior tube surrounding the light source may be connected to adjacent tubes. Suitable ventilation means may be utilized with an intake at one end and an outlet at the other end. They may be utilized for heating purposes or otherwise discarded.

According to one embodiment of the present invention, there are provided trays similar to that shown in Figure 6 et seq. Each tray 24 has a wall 26 from which there are provided side walls 28 and 30. Formed in wall 26 are a plurality of frustoconical plant receiving receptacles 32. At the smaller end of frustoconical plant receiving receptacles 32 there is provided an opening 34 through which the plant may grow. Opening 34 is relatively small and is just sufficient for a plant 36 to grow. This arrangement prevents the loss of the "soil" or other medium in which the plant grows. At its wider end, frustoconical plant receptacle 32 has a rear opening 38 which may be covered by a suitable material as will be discussed hereinbelow.

As shown in Figure 9 et seq, there may be provided an arrangement in which a base 42 has a bottom wall 44 and a pair of side walls 46. Openings 48 are provided in bottom wall 44. There are also provided trays 56 for receiving a plant growing medium or soil. Trays 56 may be formed to have a bottom of water permeable material or they are apertured. A cover 50 is provided and which has a plurality of relatively small apertures 52. Each tray 56 is designed to hook with a center member 54 such that the tray may be rotated upwardly for removal. Such arrangements permit the insertion and the removal of the

receptacles 56 in a simple and straight forward fashion.

In greater detail, center member 54 is provided with a pair of U-shaped springs 68 which are designed to exert pressure away from center member 54. An end wall 45 of base 42 has a pair of slots 70 formed therein. An end wall of tray 56 has a pair of tabs 72 extending outwardly therefrom. In this arrangement, an end of tray 56 can be inserted next to center member 54 such that springs 68 exert a biasing force on tray 56. The user can exert a force on tray 56 such that tabs 72 will engage within slots 70. To facilitate the placement of tray 56, a handle 74 may be provided.

A further embodiment of tray 58 is illustrated in Figures 14 and 15. Tray 58 is provided with cylindrical plant receiving receptacles 60. Reinforcing ribs 62 may be utilized since the receptacles are larger.

On its other side, a covering 64 may be provided, covering 64 having slits 66 formed therein to permit the insertion of seedlings and/or seeds as appropriate.

It will be understood that the above described embodiment is for purposes of illustration only and that changes and modifications may be made thereto without departing from the spirit and scope of the invention.

WE CLAIM:

1. A growing apparatus comprising:
 - a rotatable drum (12);
 - a light source (15) situated interiorly of said rotatable drum;
 - a plurality of plant receiving devices (16) extending transversely of said drum and being located interiorly thereof;
 - said plant receiving devices (16) including a tray (56) having a plurality of plant receiving receptacles (32) formed therein, each of said plant receiving receptacles (32) having a frustoconical configuration with a narrow end of said frustoconical configuration facing interiorly of said drum towards said light source.
2. The apparatus of Claim 1 wherein said plant receiving receptacles (32) contain a plant growing medium therein.
3. The apparatus of Claim 2 wherein said plant receiving receptacles include a sheet material (64) extending over a wider end of said plant receiving receptacles.
4. The apparatus of Claim 1 wherein said tray (56) is retained in said plant receiving devices hingedly at one end thereof such that said tray may be inserted and removed by lifting a remote end thereof.
5. The apparatus of Claim 1 wherein said plant receiving devices further include a cover (50) for said tray, said cover having a plurality of apertures (52) therein, and a base (42), said base being designed to receive said tray.
6. The apparatus of Claim 5 wherein said base includes an end wall (45).
7. The apparatus of Claim 6 wherein said plant receiving devices include a center member (54), said center member having a spring (68) mounted therein, said spring being

arranged to engage said tray and exert a biasing force thereon.

8. The apparatus of Claim 7 wherein said base end wall includes a pair of slots (70) formed therein and said tray includes a pair of tab members arranged to be insertable into said apertures of said base member.

9. An arrangement for growing plants, the arrangement including a plurality of apparati according to Claim 1, said apparati being stacked on top of one another and arranged in a plurality of rows.

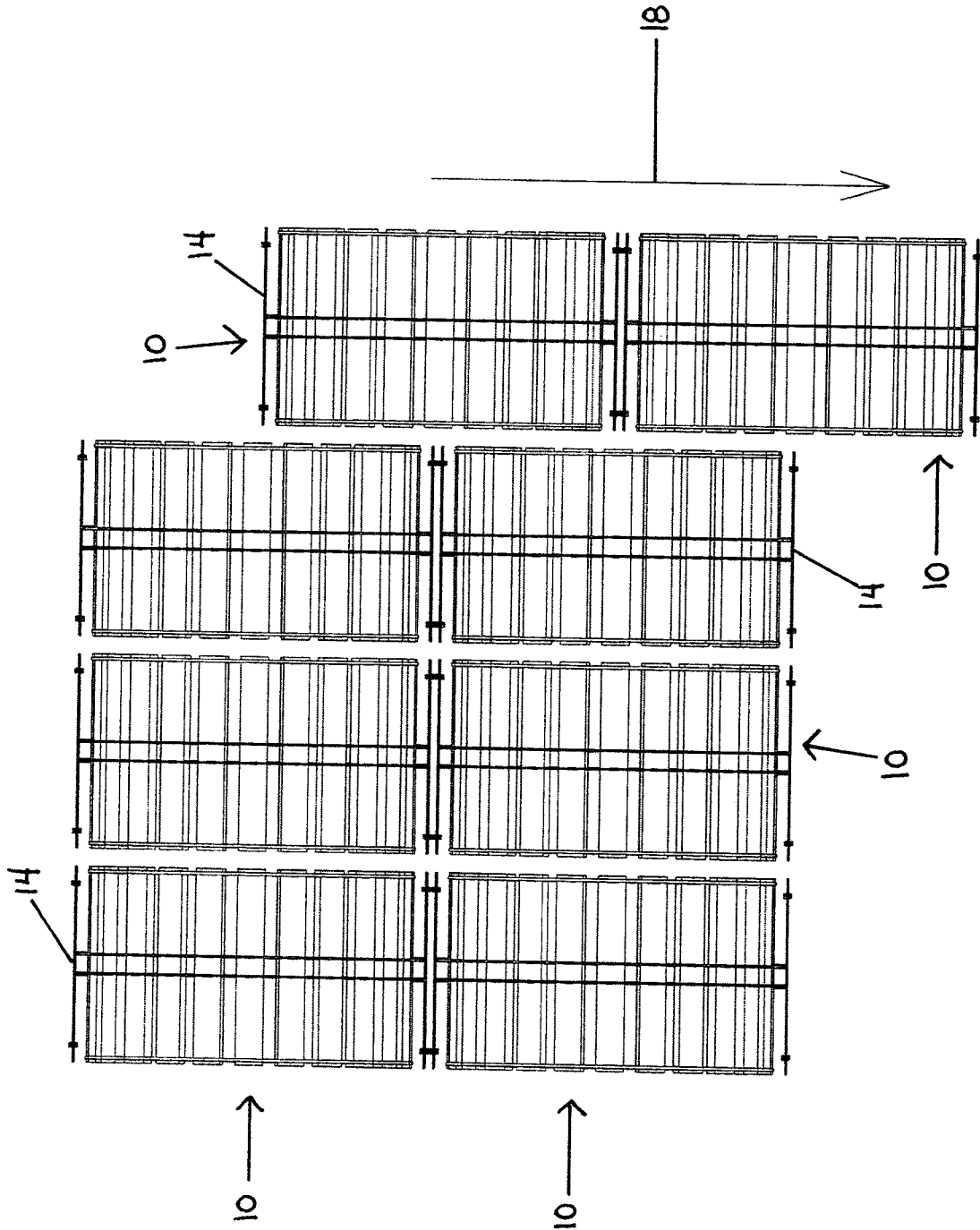
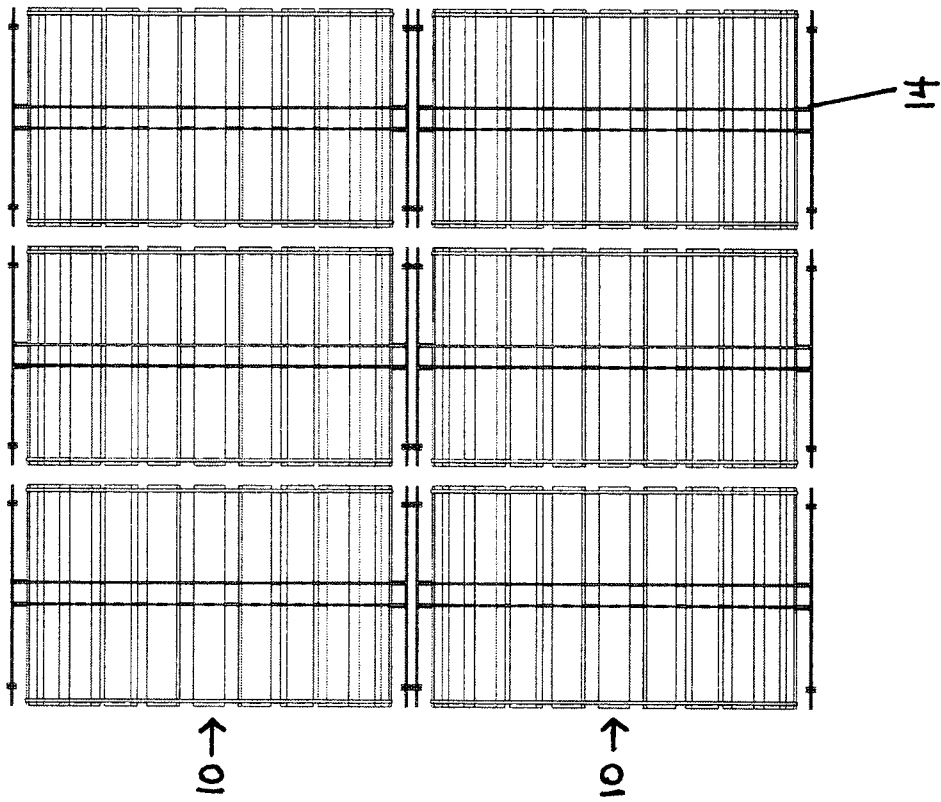
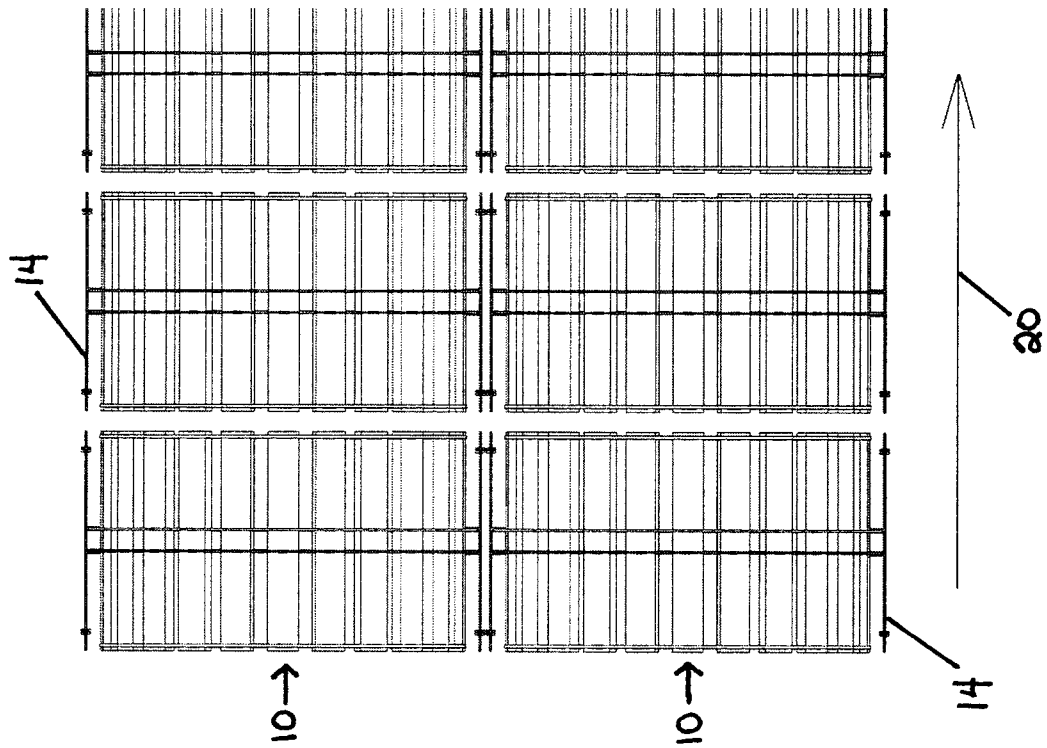
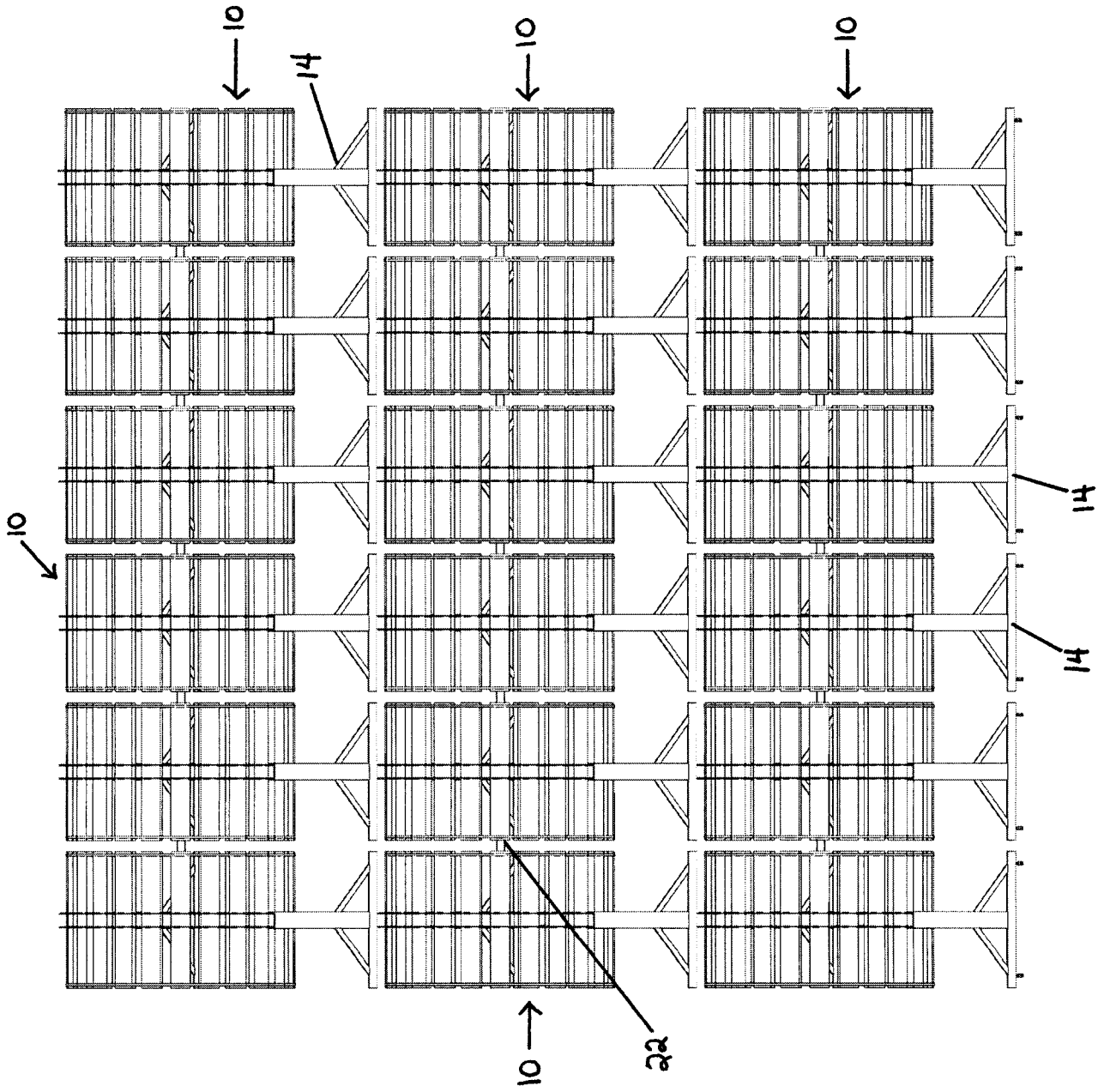

Fig.1



Fig

FIG



Fig

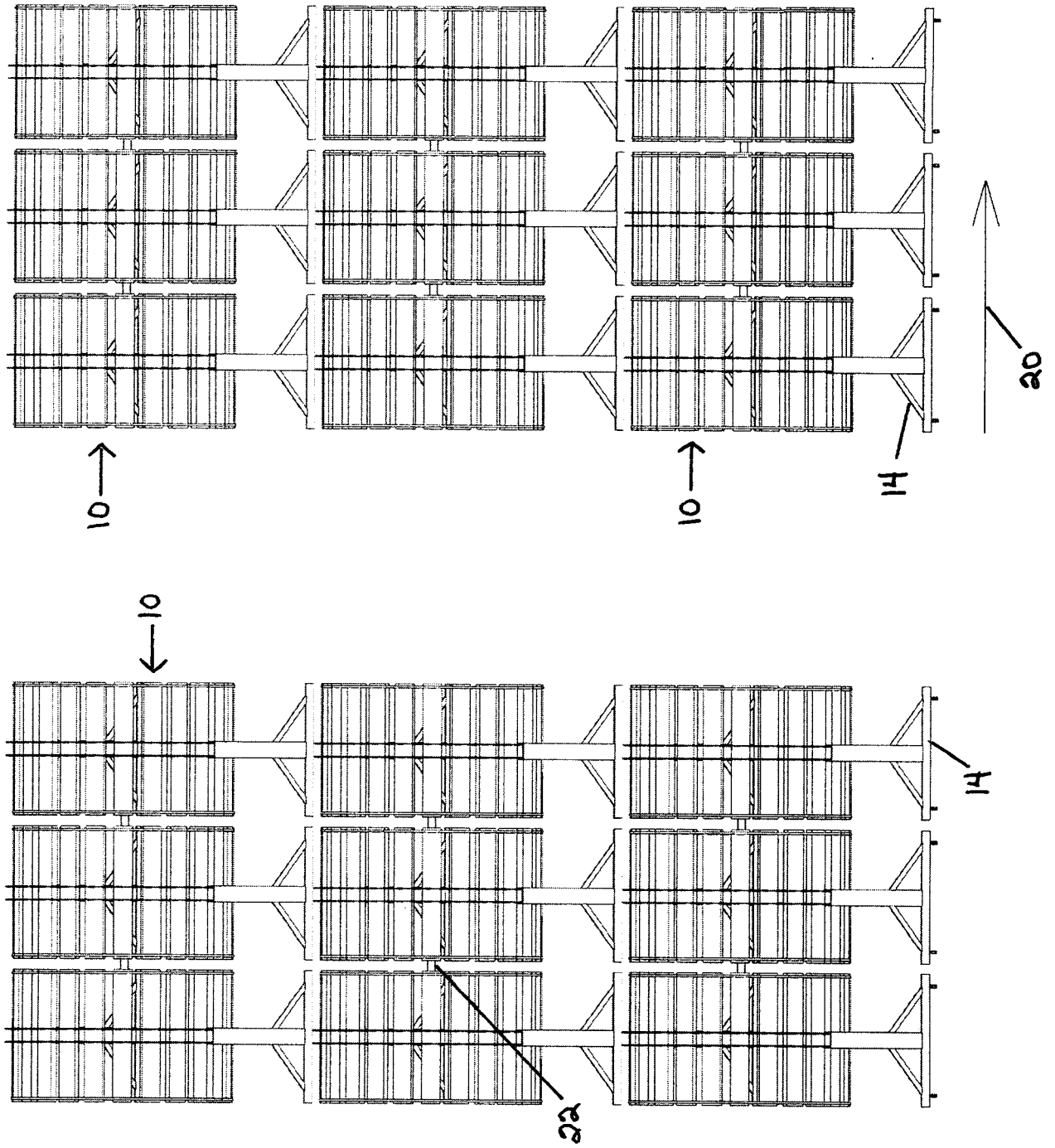

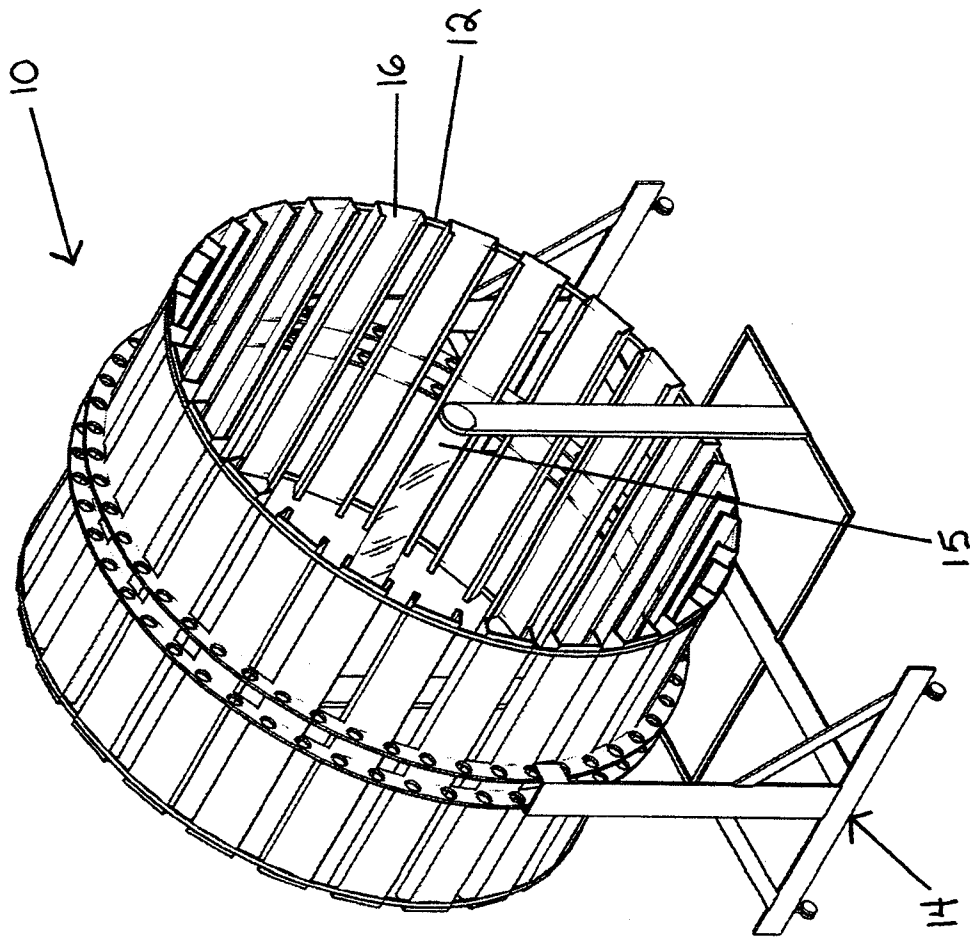

Fig. 5

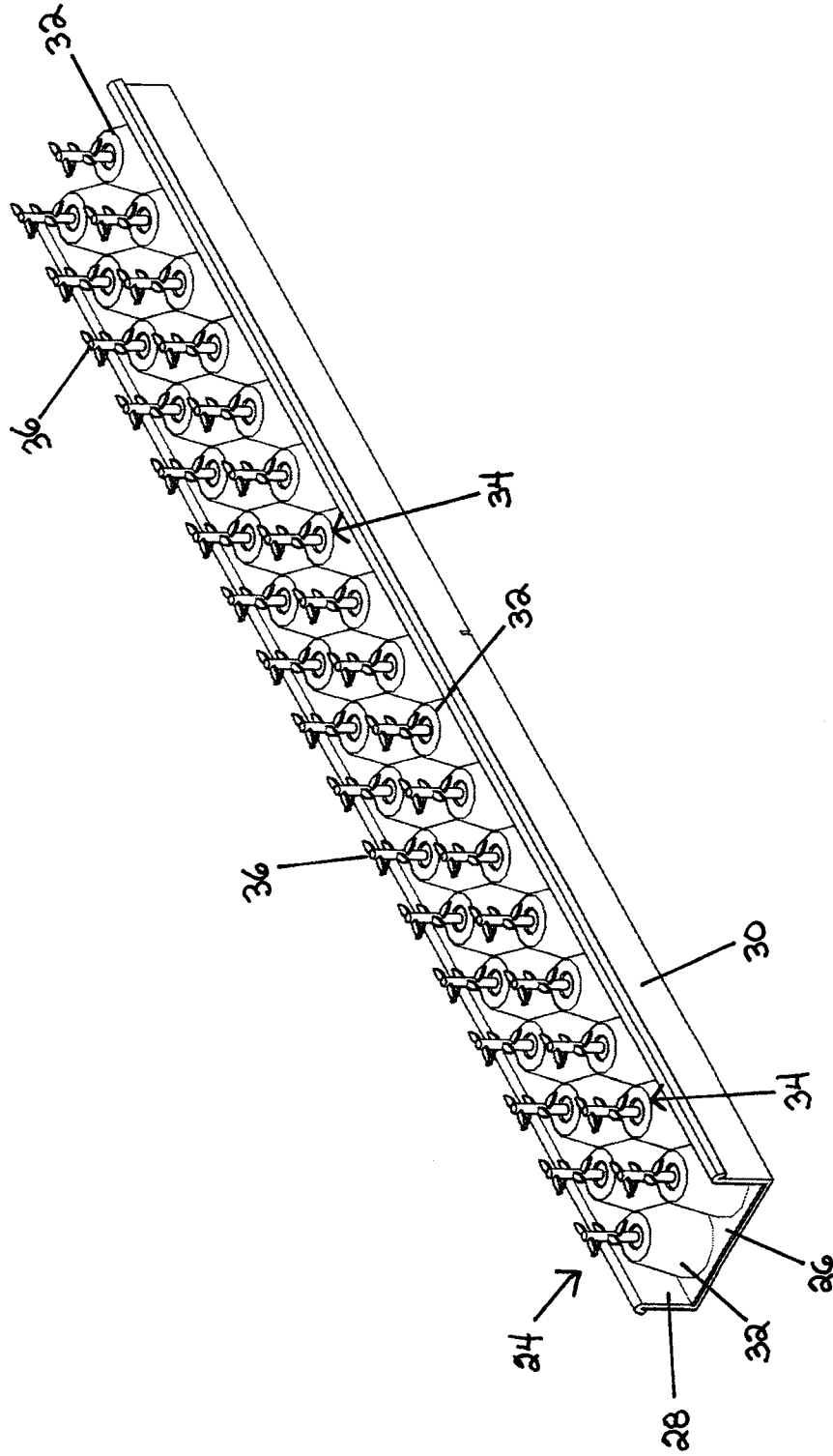

Fig.6

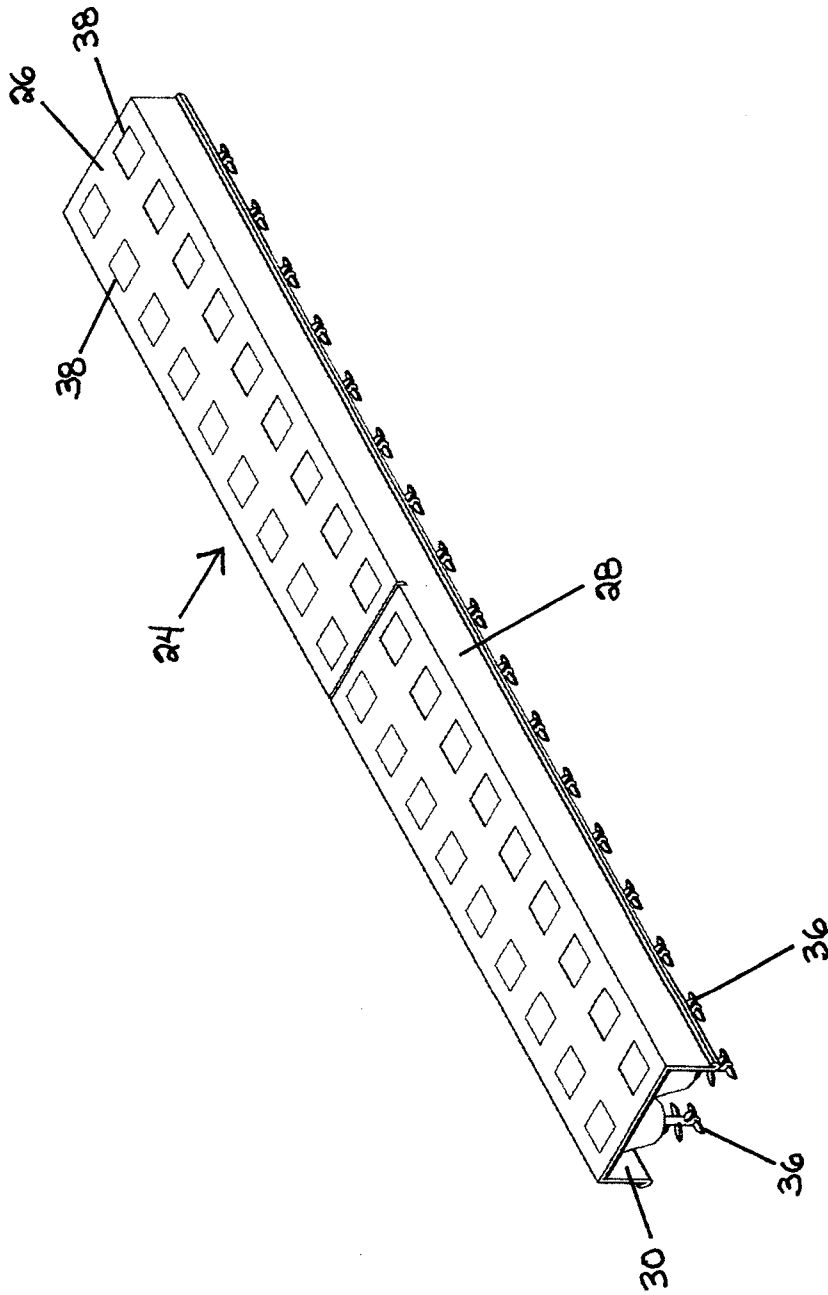

Fig.7

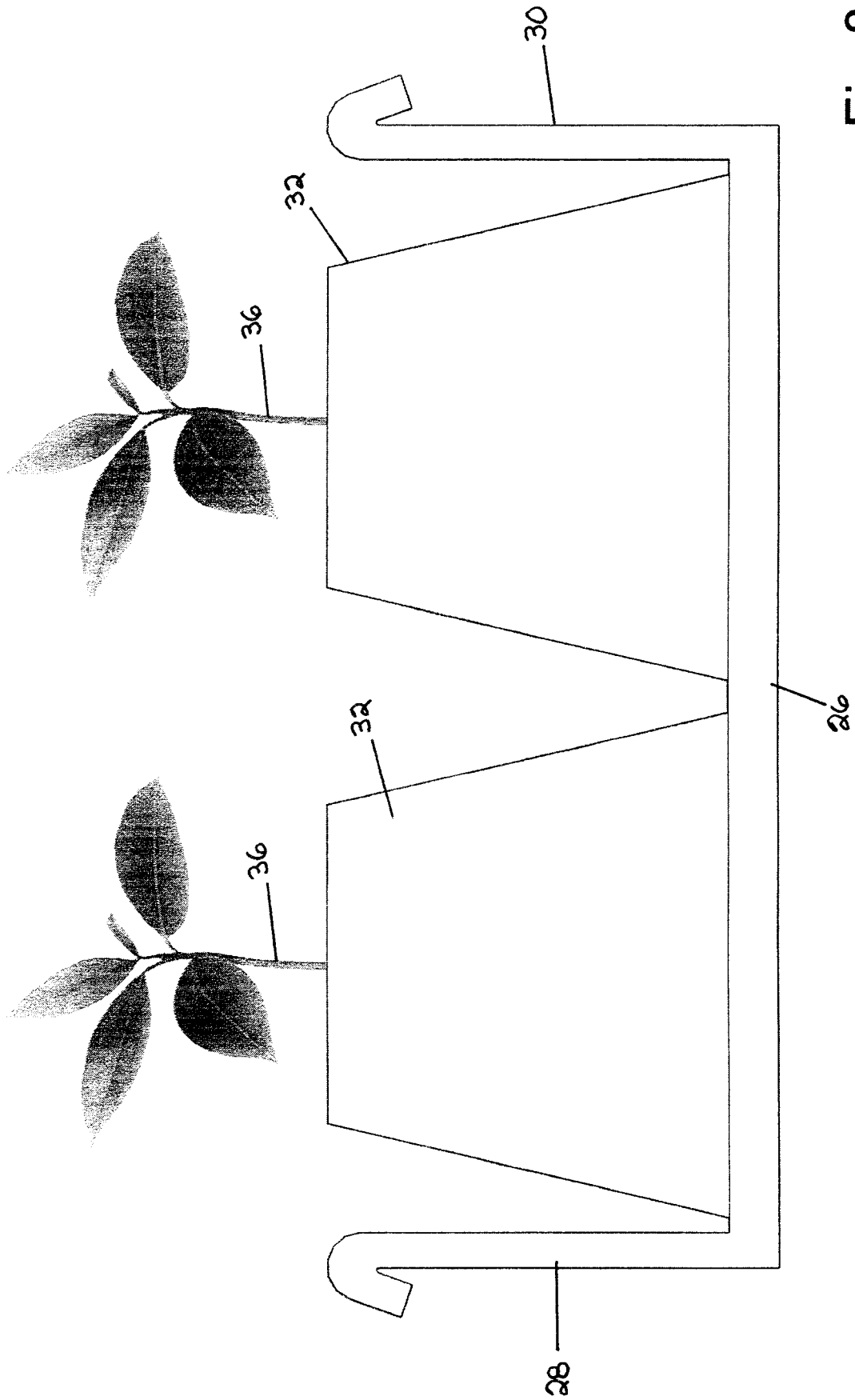

Fig.8

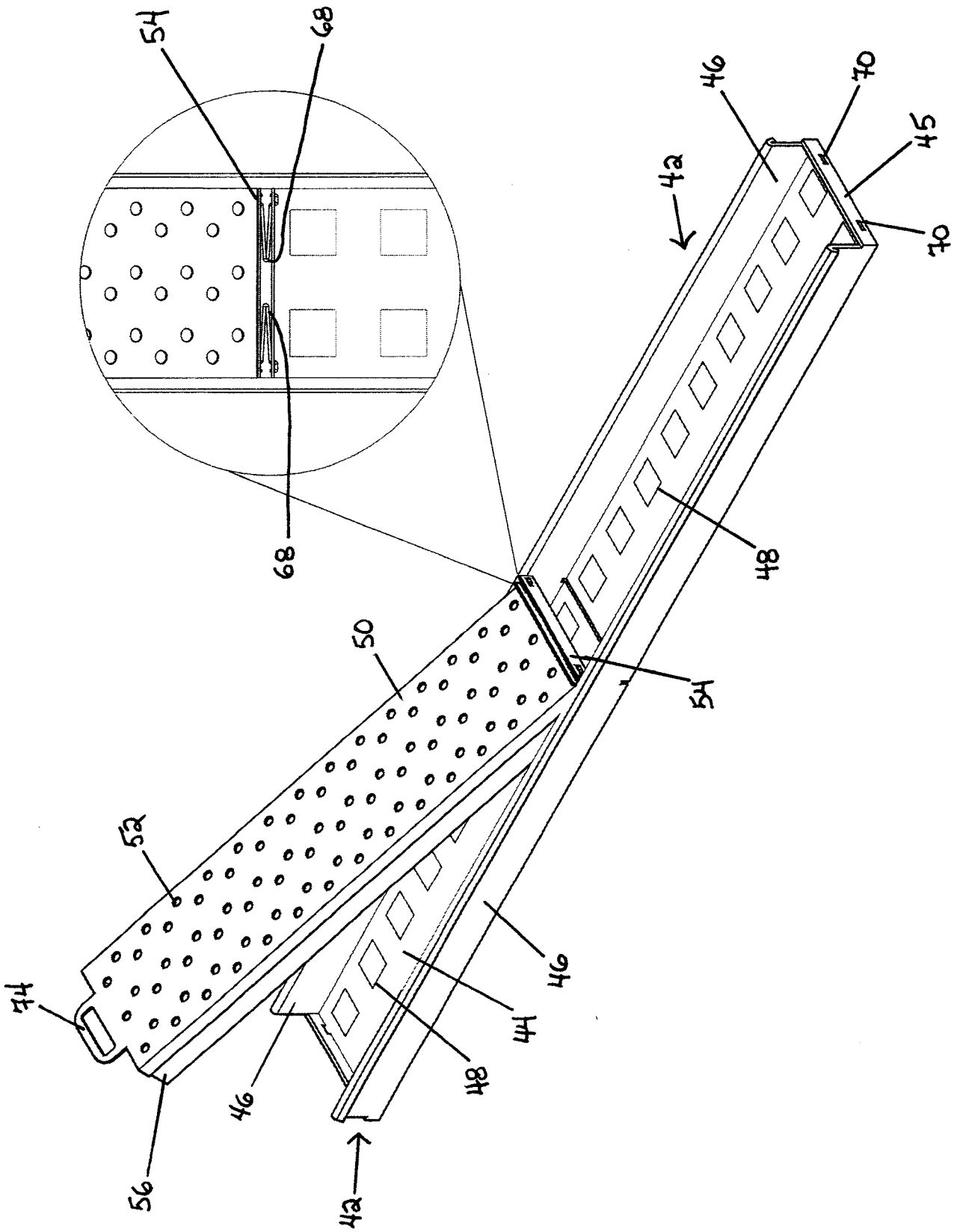

Fig.9

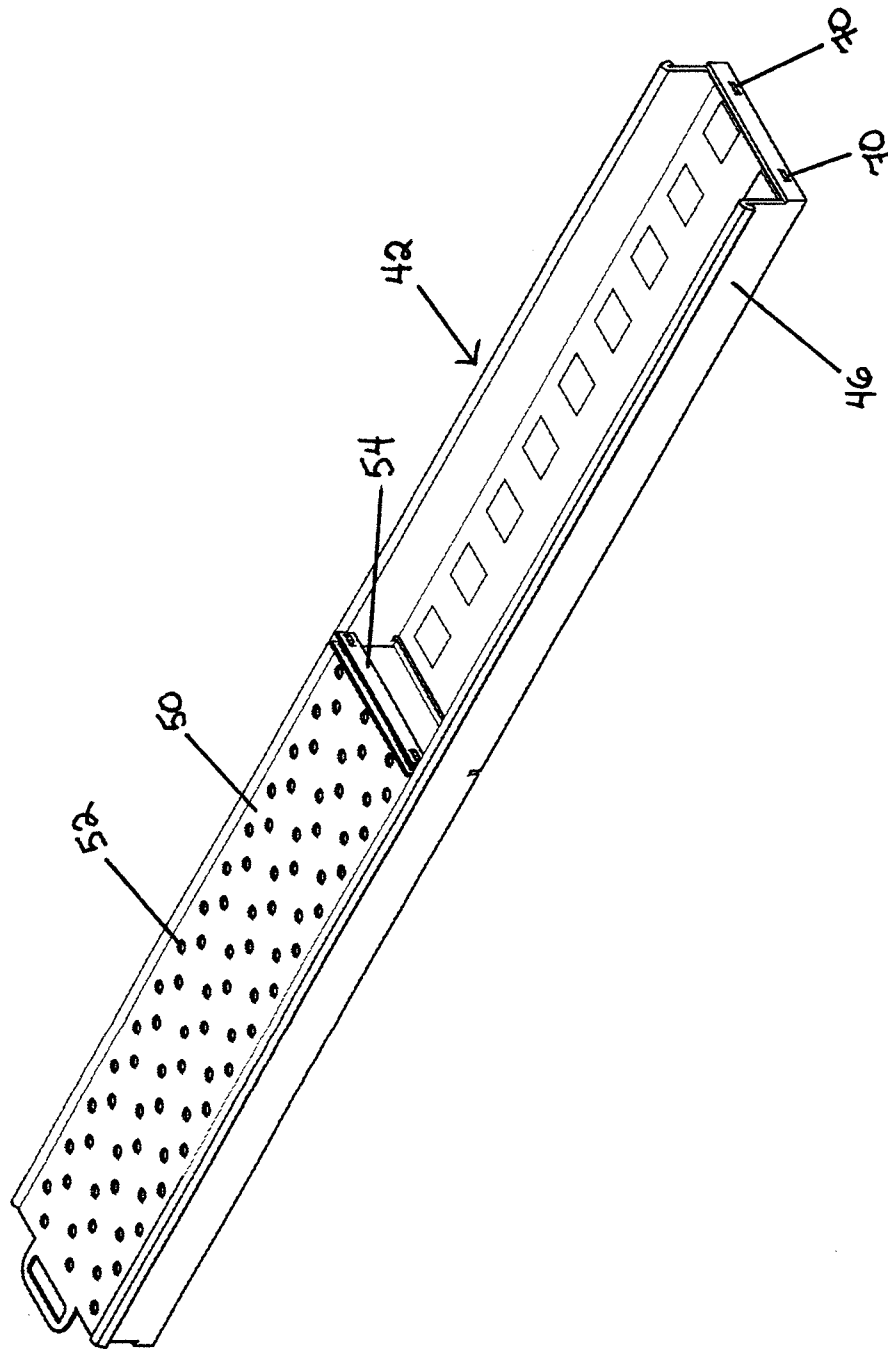

Fig.10

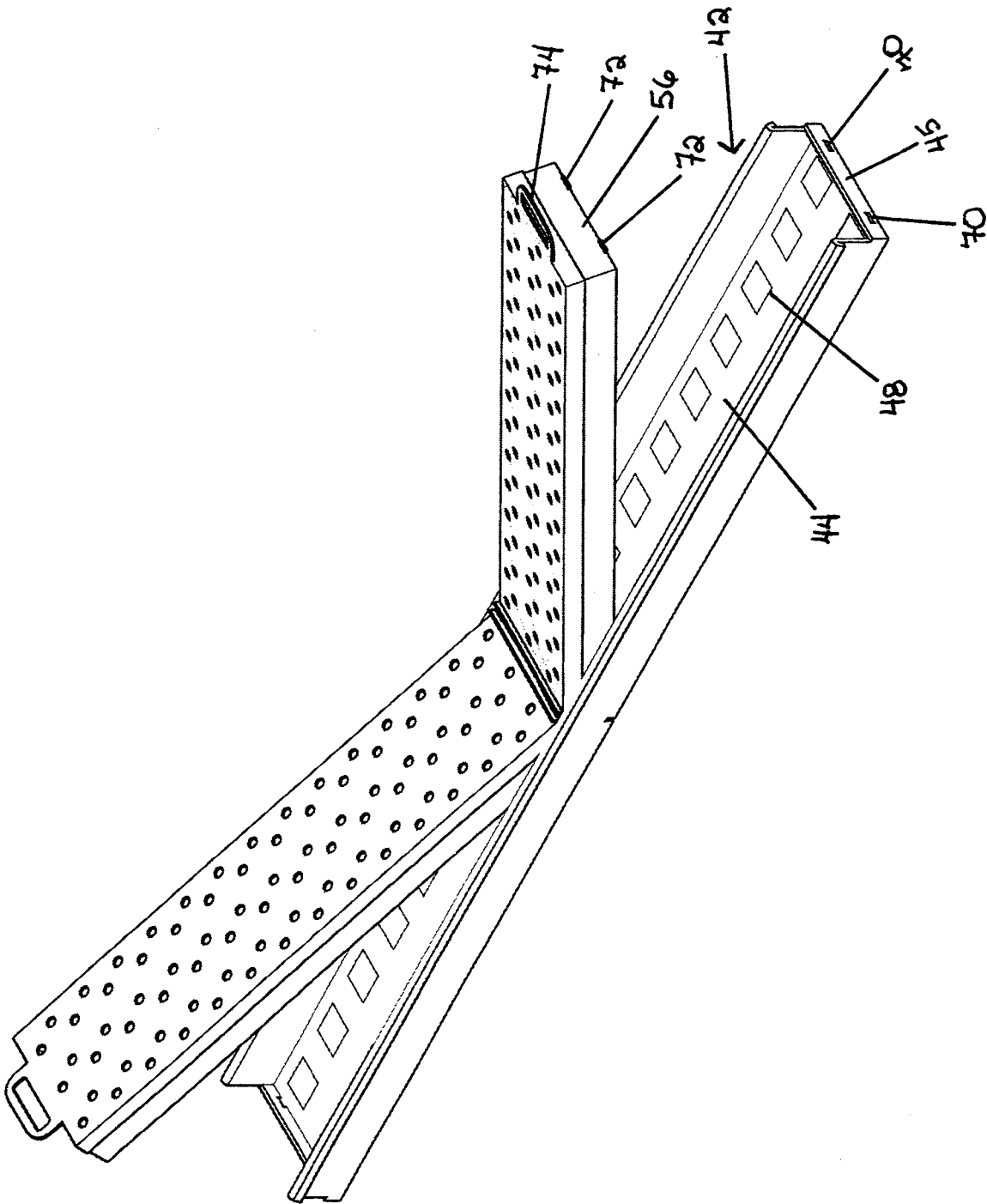

Fig.11

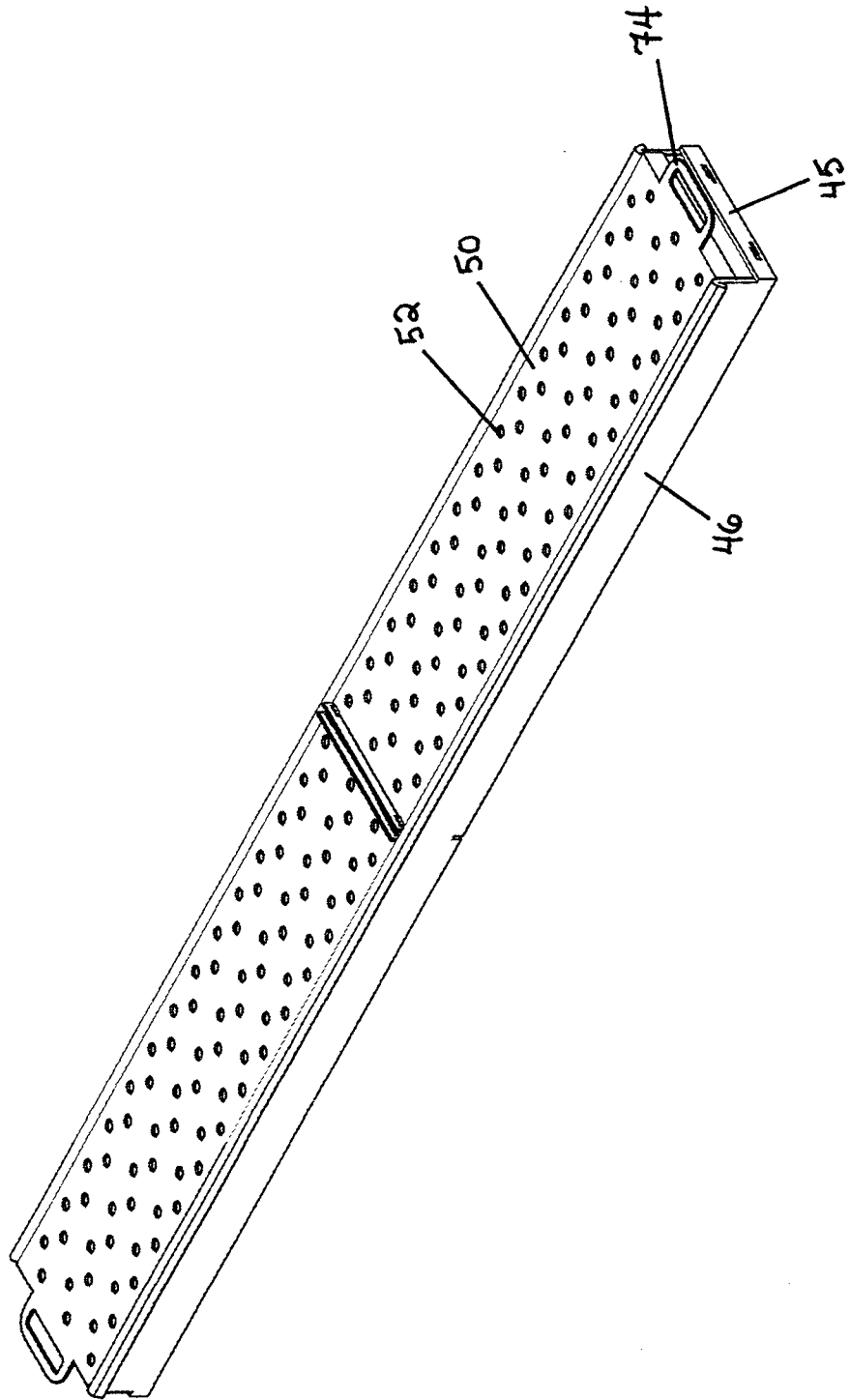
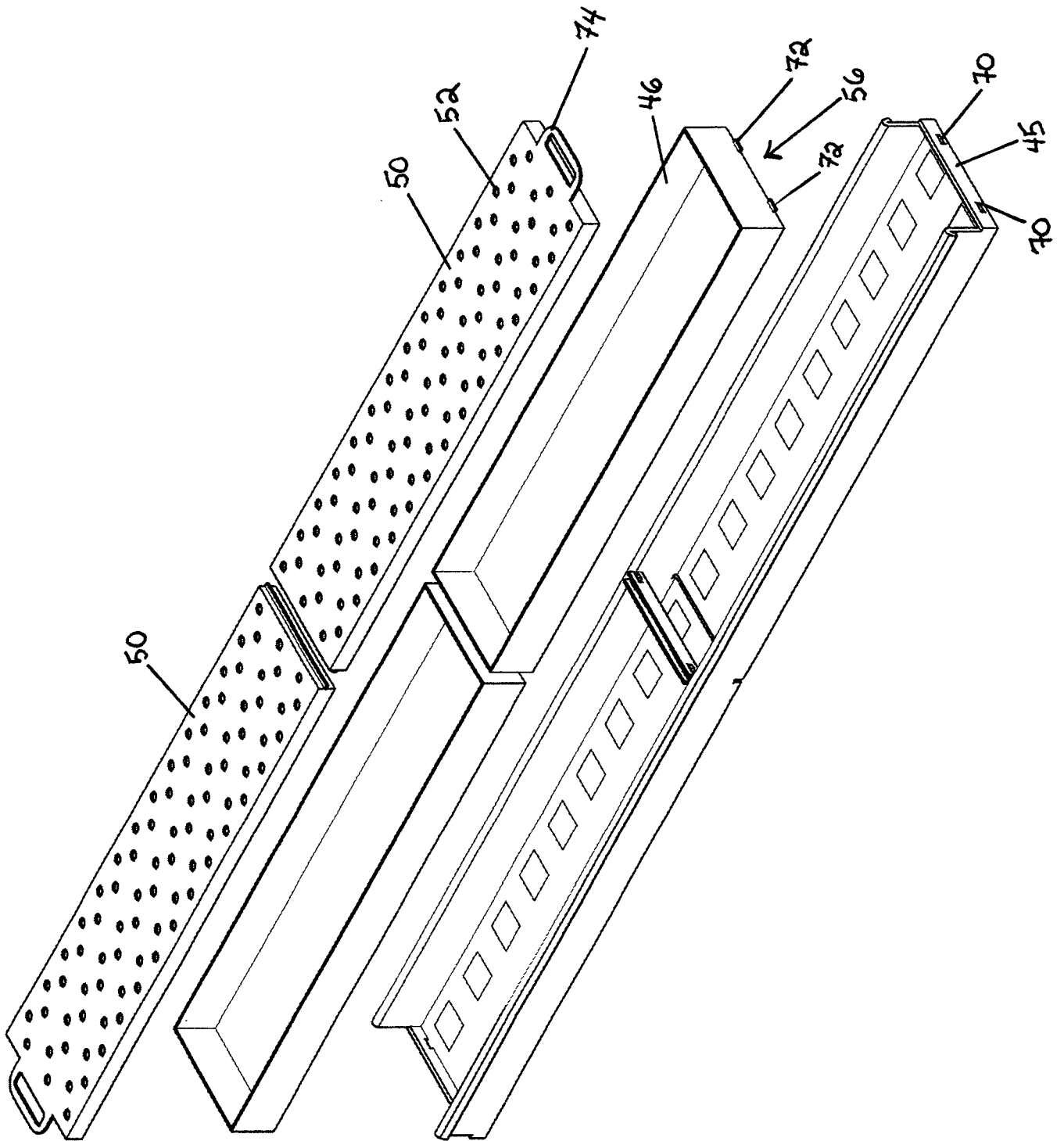

Fig.12

Fig. 13



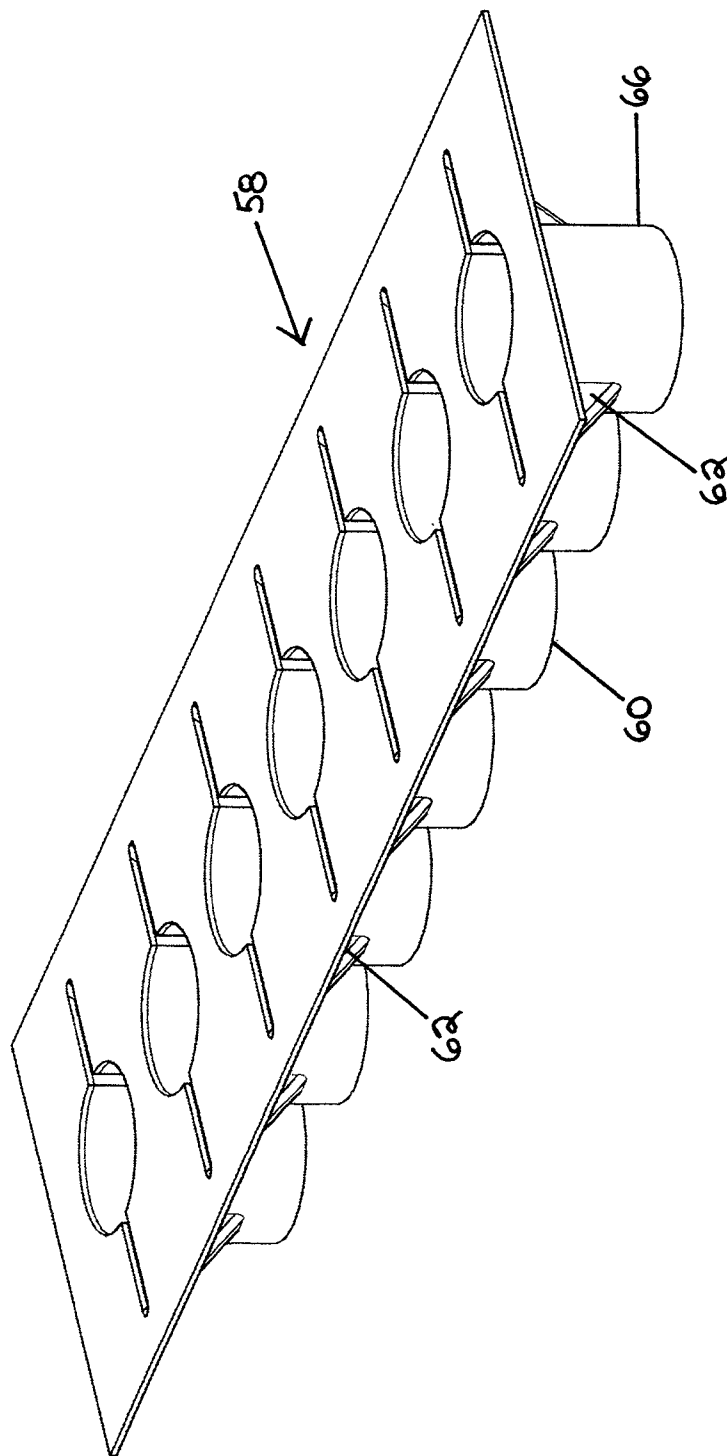

Fig.14

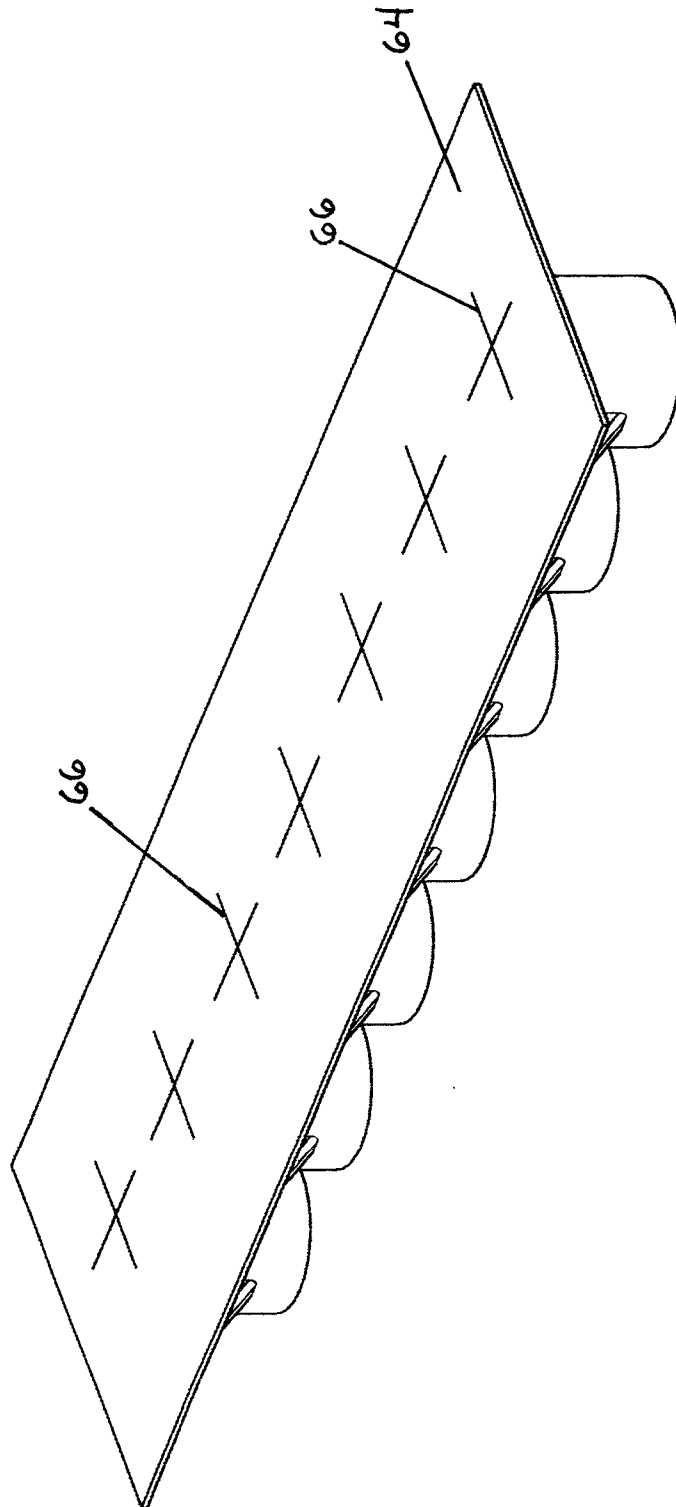

Fig.15

INTERNATIONAL SEARCH REPORT

International application No.

PCT/CA2017/000093

A. CLASSIFICATION OF SUBJECT MATTER
 IPC: **A01G 1/00** (2006.01), **A01G 7/00** (2006.01)

According to International Patent Classification (IPC) or to both national classification and IPC

B. FIELDS SEARCHED

Minimum documentation searched (classification system followed by classification symbols)

IPC: A01G, A01G 1/00 (2006.01), A01G 7/00 (2006.01), A01G 9/00 (2006.01), A01G 9/02 (2006.01), A01G 31/00 (2006.01), A01G 31/02 (2006.01), A01G 31/04 (2006.01), A01G 31/06 (2006.01)

Documentation searched other than minimum documentation to the extent that such documents are included in the fields searched

Electronic database(s) consulted during the international search (name of database(s) and, where practicable, search terms used)

Databases: Canadian Patent Database (CPD), Questel Orbit (Fampat), Google Patents, Google Search Engine

Keywords: grow, plant, vegetable, vegetation, drum, rotation, rotate, rotatable, light, receiving, receptacle, container, tray, opening, aperture, cone, conical, frustoconical, interior, internal, inside, hinge, cover, lid, base, support, spring, bias, slot, slit, tab, stack, row, column, modular

C. DOCUMENTS CONSIDERED TO BE RELEVANT

Category*	Citation of document, with indication, where appropriate, of the relevant passages	Relevant to claim No.
X Y	CA 2659658 A1 (BRUSATORE, N. G.) 23 September 2010 (23-09-2010) *Whole Document*	1 and 2 9
Y	US 7181886 B2 (BOURGOIN, E. et al.) 27 February 2007 (27-02-2007) *Whole Document*	9
A	CA 2460465 A1 (DUMONT, G.) 10 September 2004 (10-09-2004) *Whole Document*	
A	CA 2343254 A1 (MARCHILDON, T.) 30 July 2001 (30-07-2001) *Whole Document*	
A	CA 2401737 A1 (LEDUC, M. et al.) 16 December 2002 (16-12-2002) *Whole Document*	

Further documents are listed in the continuation of Box C.

See patent family annex.

* "A" "E" "L" "O" "P"	Special categories of cited documents: document defining the general state of the art which is not considered to be of particular relevance earlier application or patent but published on or after the international filing date document which may throw doubts on priority claim(s) or which is cited to establish the publication date of another citation or other special reason (as specified) document referring to an oral disclosure, use, exhibition or other means document published prior to the international filing date but later than the priority date claimed	"T" "X" "Y" "&"	later document published after the international filing date or priority date and not in conflict with the application but cited to understand the principle or theory underlying the invention document of particular relevance; the claimed invention cannot be considered novel or cannot be considered to involve an inventive step when the document is taken alone document of particular relevance; the claimed invention cannot be considered to involve an inventive step when the document is combined with one or more other such documents, such combination being obvious to a person skilled in the art document member of the same patent family
--------------------------------------	--	--------------------------	--

Date of the actual completion of the international search
27 July 2017 (27-07-2017)

Date of mailing of the international search report
18 August 2017 (18-08-2017)

Name and mailing address of the ISA/CA
 Canadian Intellectual Property Office
 Place du Portage I, C114 - 1st Floor, Box PCT
 50 Victoria Street
 Gatineau, Quebec K1A 0C9
 Facsimile No.: 819-953-2476

Authorized officer

Genevieve Scott (819) 639-7897

INTERNATIONAL SEARCH REPORT
Information on patent family members

International application No.
PCT/CA2017/000093

Patent Document Cited in Search Report	Publication Date	Patent Family Member(s)	Publication Date
CA2659658A1	23 September 2010 (23-09-2010)	US2010236147A1 US7818917B2 US2011061294A1 US7984586B2 WO2010110844A1	23 September 2010 (23-09-2010) 26 October 2010 (26-10-2010) 17 March 2011 (17-03-2011) 26 July 2011 (26-07-2011) 30 September 2010 (30-09-2010)
US7181886B2	27 February 2007 (27-02-2007)	US2005011119A1 CA2466644A1	20 January 2005 (20-01-2005) 12 November 2004 (12-11-2004)
CA2460465A1	10 September 2004 (10-09-2004)	CA2460465C CA2421389A1 CA2431523A1 US2005055878A1 US7401437B2	09 September 2008 (09-09-2008) 10 September 2004 (10-09-2004) 09 December 2004 (09-12-2004) 17 March 2005 (17-03-2005) 22 July 2008 (22-07-2008)
CA2343254A1	30 July 2001 (30-07-2001)	CA2343254C US2002144461A1 US6604321B2	26 March 2002 (26-03-2002) 10 October 2002 (10-10-2002) 12 August 2003 (12-08-2003)
CA2401737A1	16 December 2002 (16-12-2002)	CA2401737C CA2396317A1 US2004060491A1 US6840007B2	31 August 2004 (31-08-2004) 08 November 2002 (08-11-2002) 01 April 2004 (01-04-2004) 11 January 2005 (11-01-2005)