



US 20160155326A1

(19) **United States**
(12) **Patent Application Publication**
Ricci et al.

(10) **Pub. No.: US 2016/0155326 A1**
(43) **Pub. Date: Jun. 2, 2016**

(54) **RELAY AND EXCHANGE PROTOCOL IN AN
AUTOMATED ZONE-BASED VEHICULAR
TRAFFIC CONTROL ENVIRONMENT**

ation No. 61/891,217, filed on Oct. 15, 2013, provi-
sional application No. 61/904,205, filed on Nov. 14,
2013, provisional application No. 61/924,572, filed on
Jan. 7, 2014, provisional application No. 61/926,749,
filed on Jan. 13, 2014.

(71) Applicant: **AutoConnect Holdings LLC**, Wellesley,
MA (US)

(72) Inventors: **Christopher P. Ricci**, Saratoga, CA
(US); **Tadd F. Wilson**, Denver, CO (US)

(21) Appl. No.: **14/941,304**

(22) Filed: **Nov. 13, 2015**

Publication Classification

(51) **Int. Cl.**
G08G 1/01 (2006.01)
(52) **U.S. Cl.**
CPC **G08G 1/01** (2013.01)

Related U.S. Application Data

(63) Continuation of application No. 14/253,836, filed on
Apr. 15, 2014.

(60) Provisional application No. 61/811,981, filed on Apr.
15, 2013, provisional application No. 61/865,954,
filed on Aug. 14, 2013, provisional application No.
61/870,698, filed on Aug. 27, 2013, provisional appli-

(57) **ABSTRACT**

Methods and systems for a traffic control system provide
arrangements and processes for managing automated
vehicles. The traffic control system can register vehicles and
then control the operation of the vehicles through a section of
roadway. The automated control includes the communication
of directions and other messages that ensure the proper func-
tion of the vehicle while under the guidance of the traffic
control system

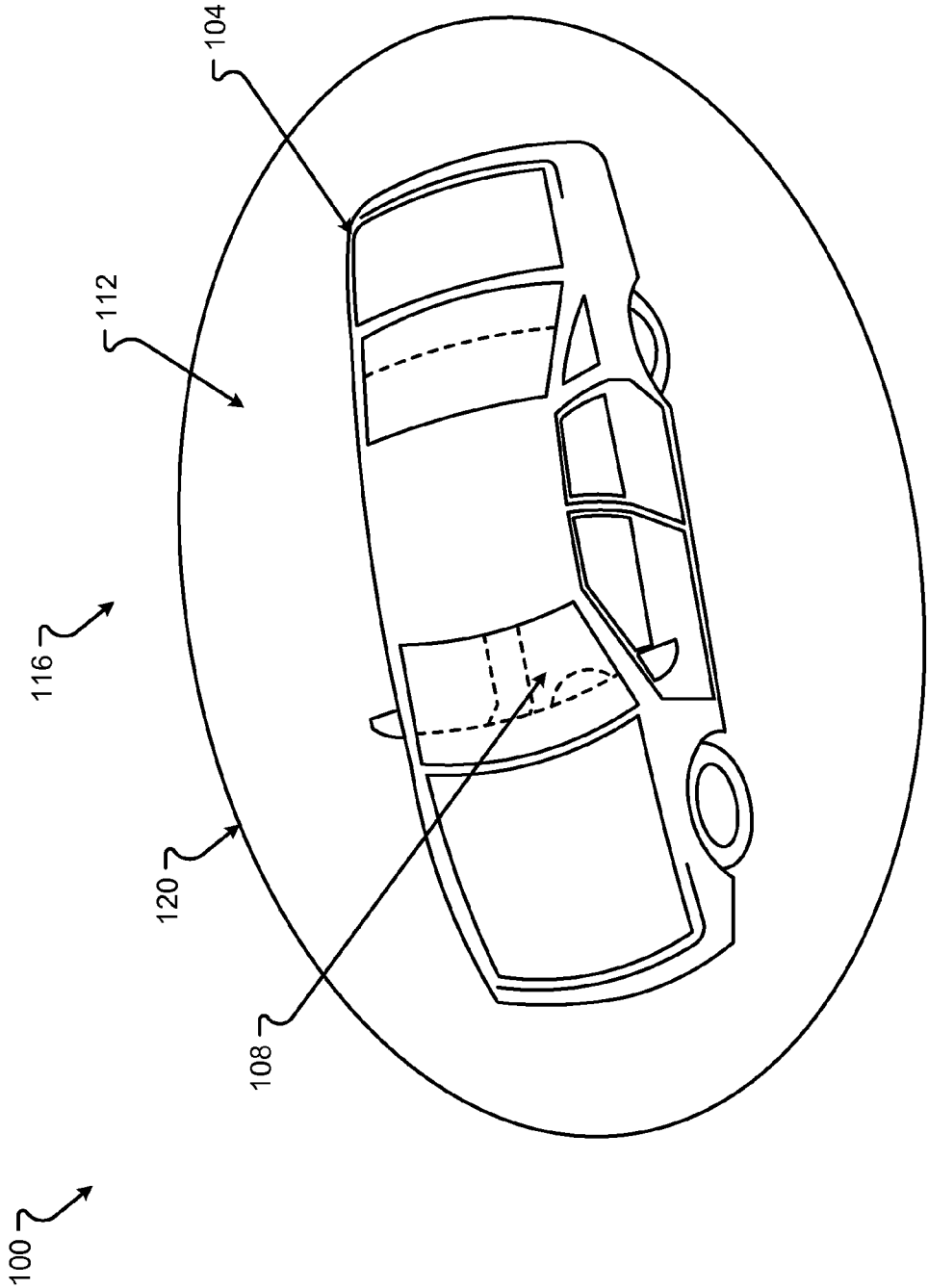

Fig. 1

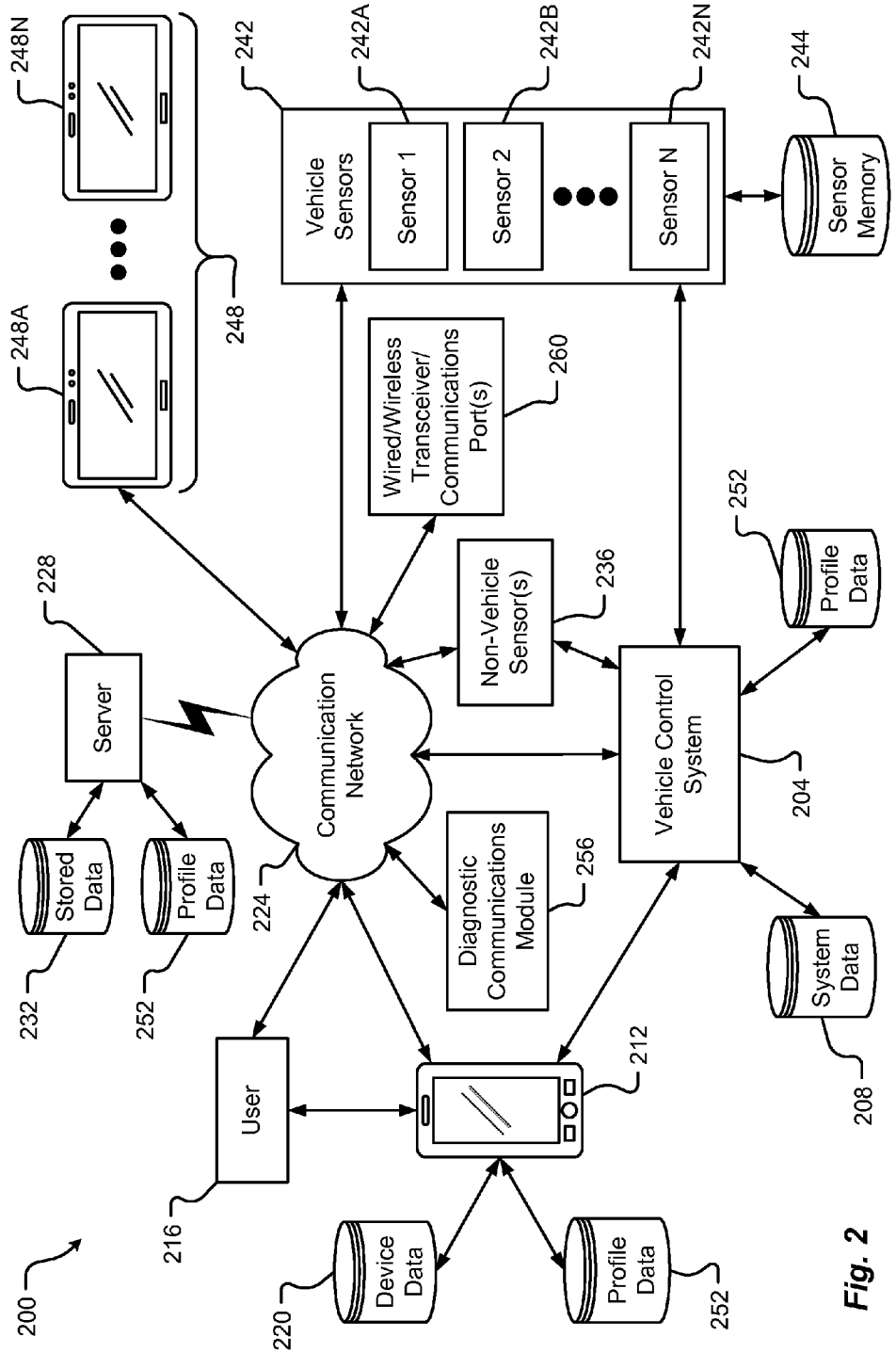

Fig. 2

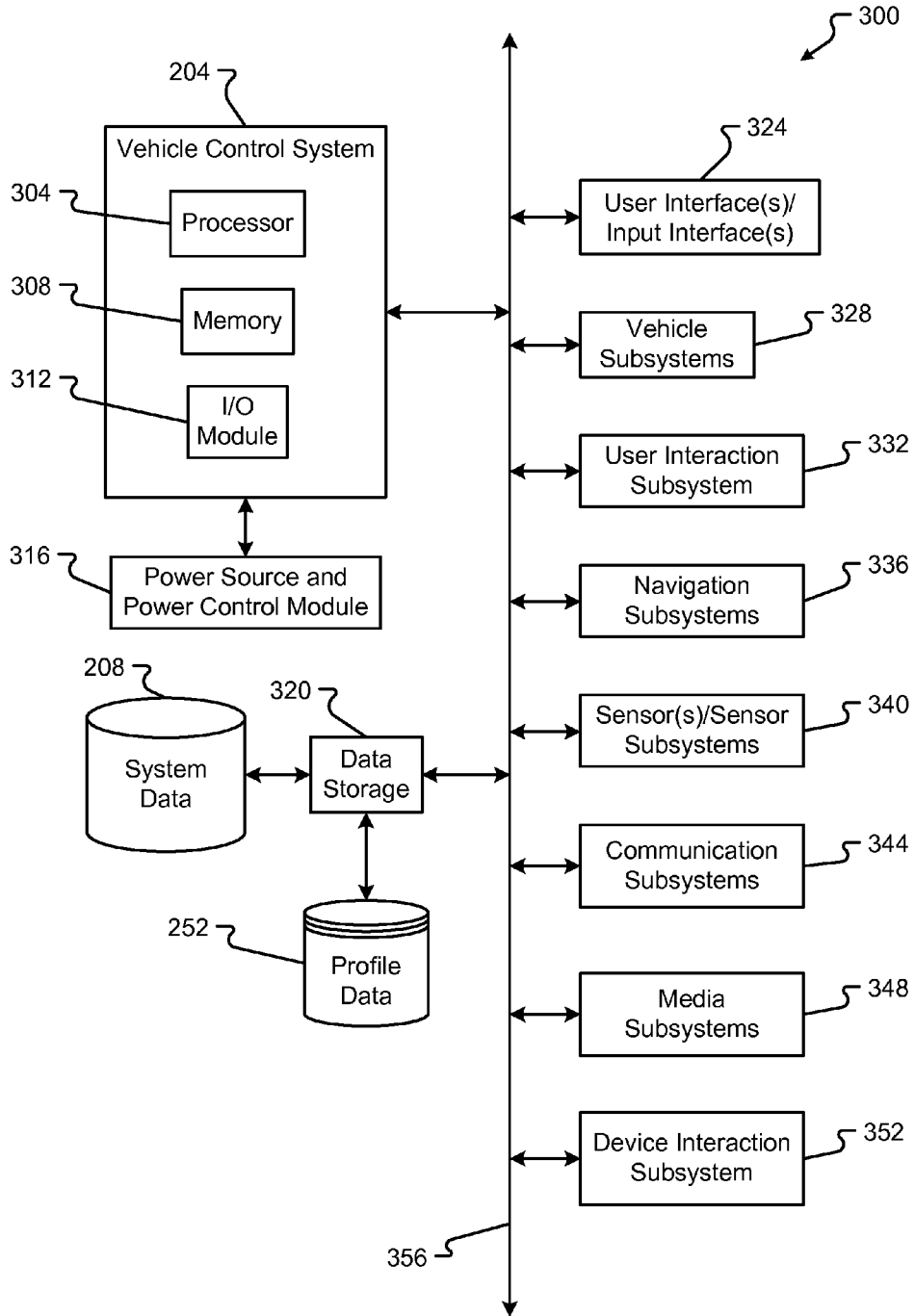

Fig. 3

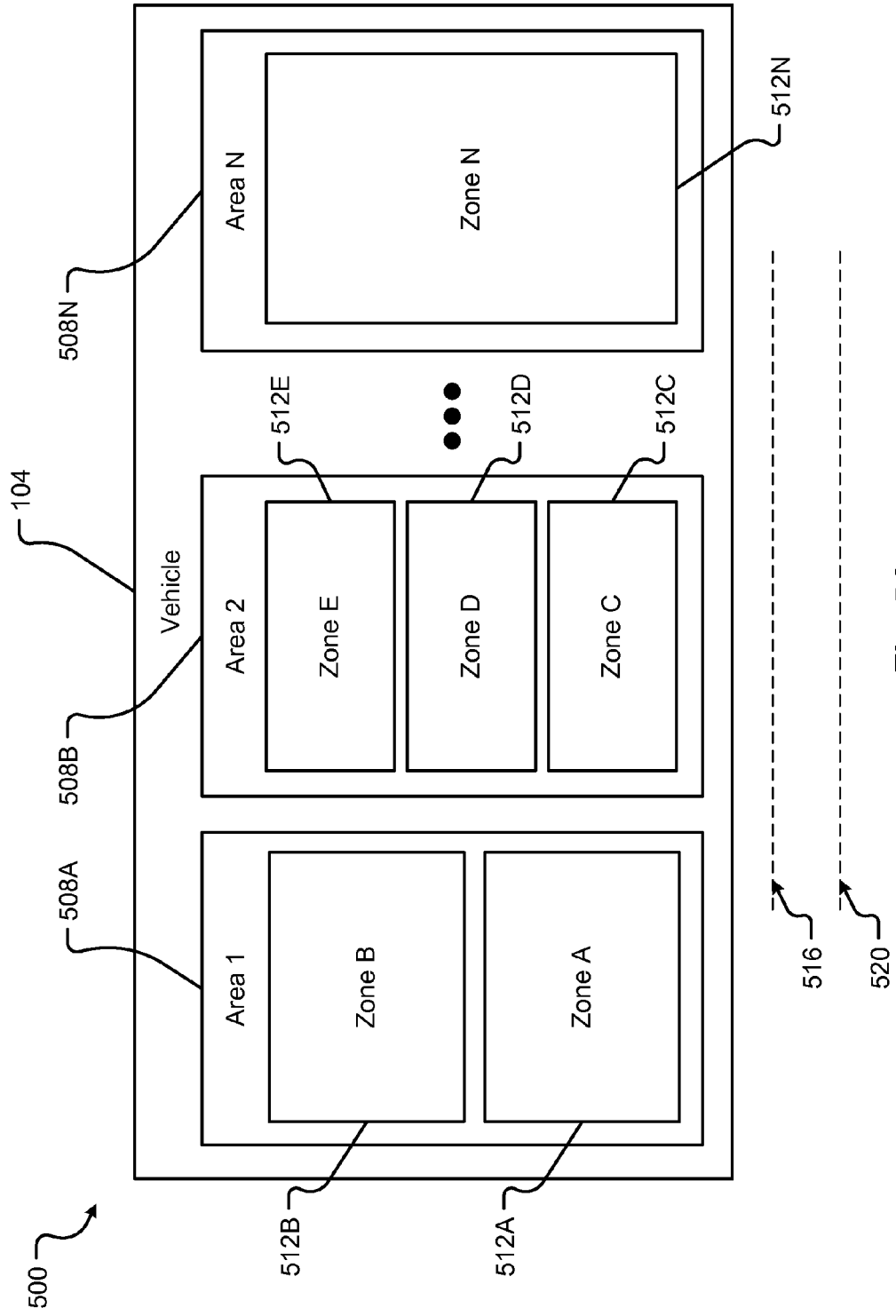
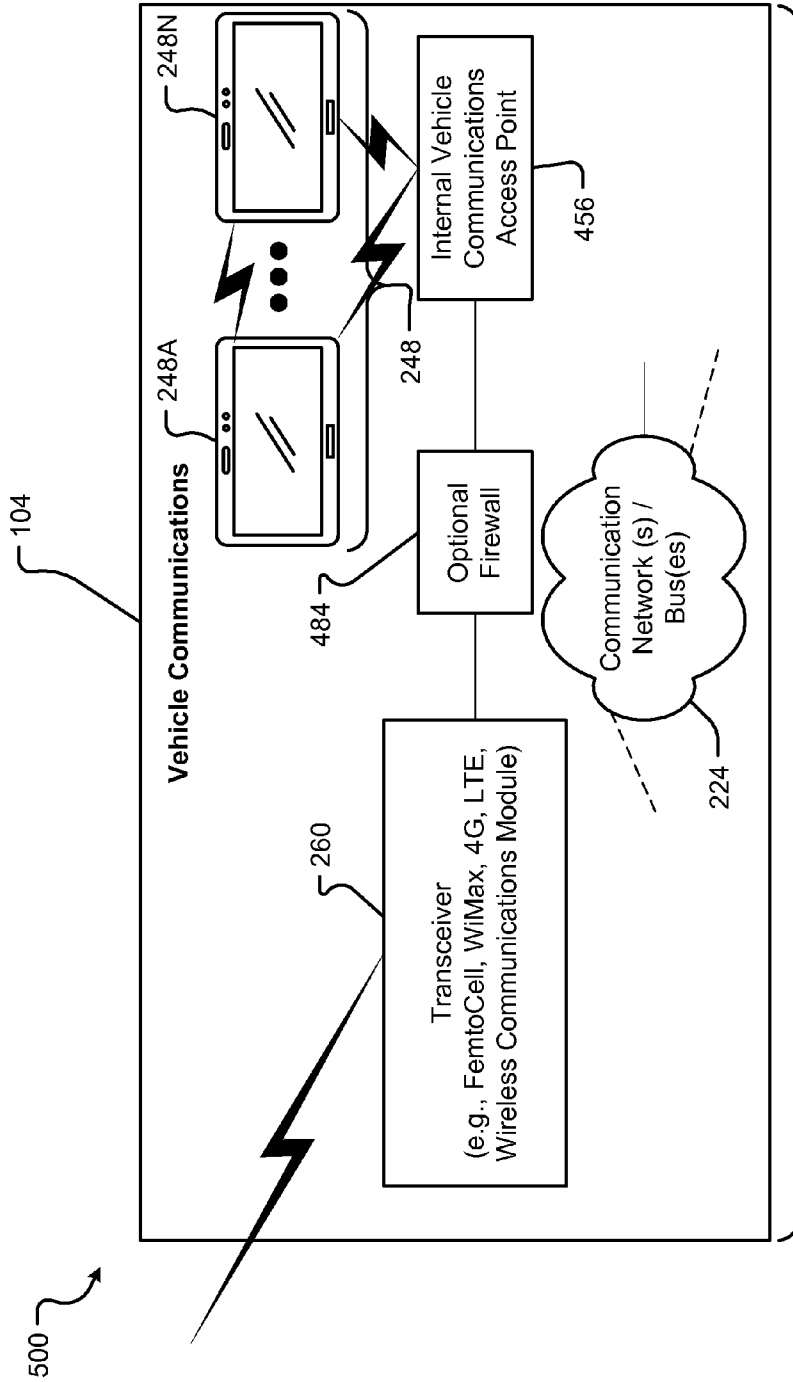

Fig. 5A



Internal Vehicle Communications between Vehicle and one or more devices, or between devices
One or more of: Bluetooth®, NFC, WiFi, Mobile Hotspot, Ethernet, 802.11(x), Point-to-Point, Point-to-Multiple Other Points, etc.

Fig. 5C

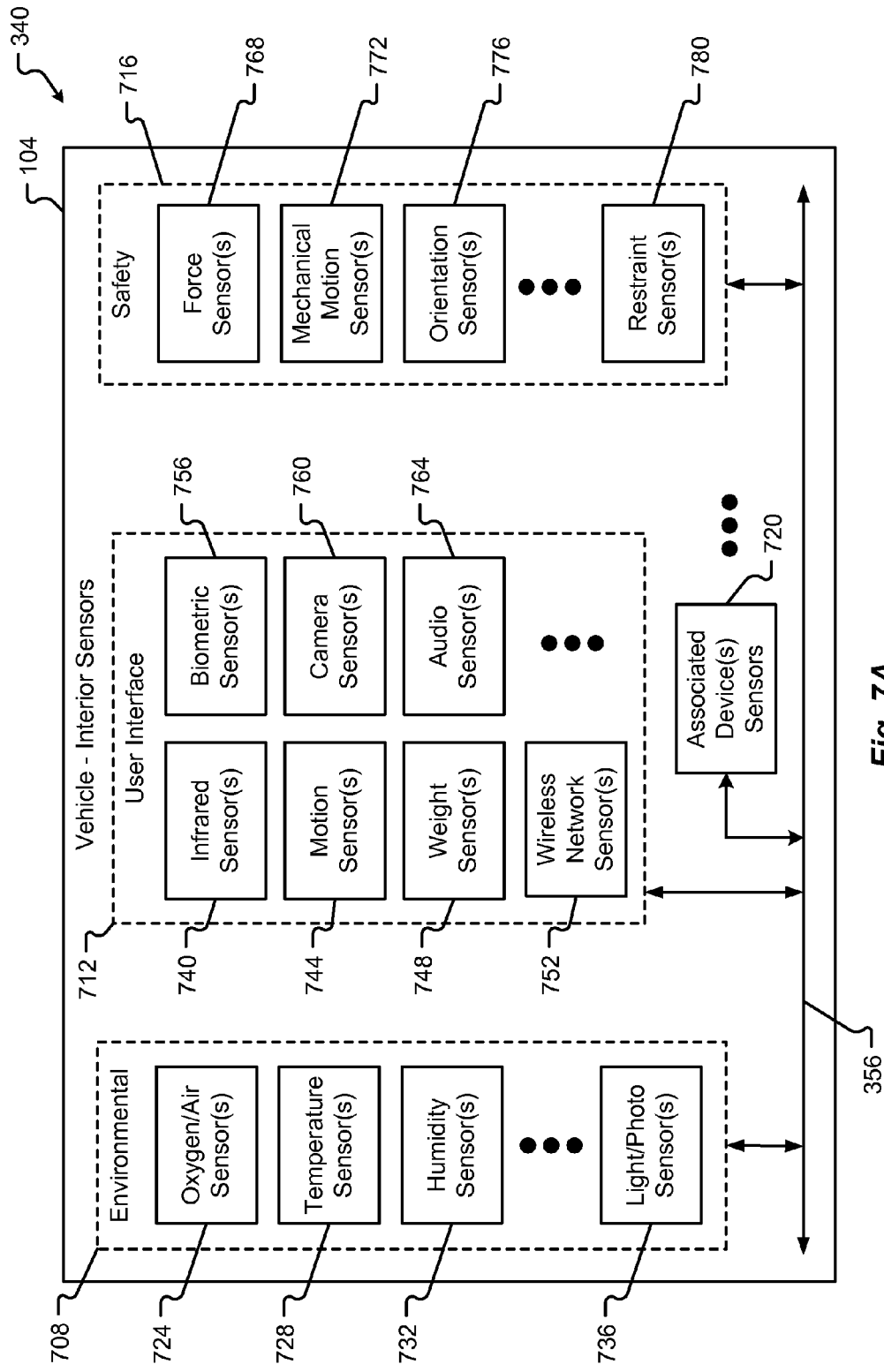

Fig. 7A

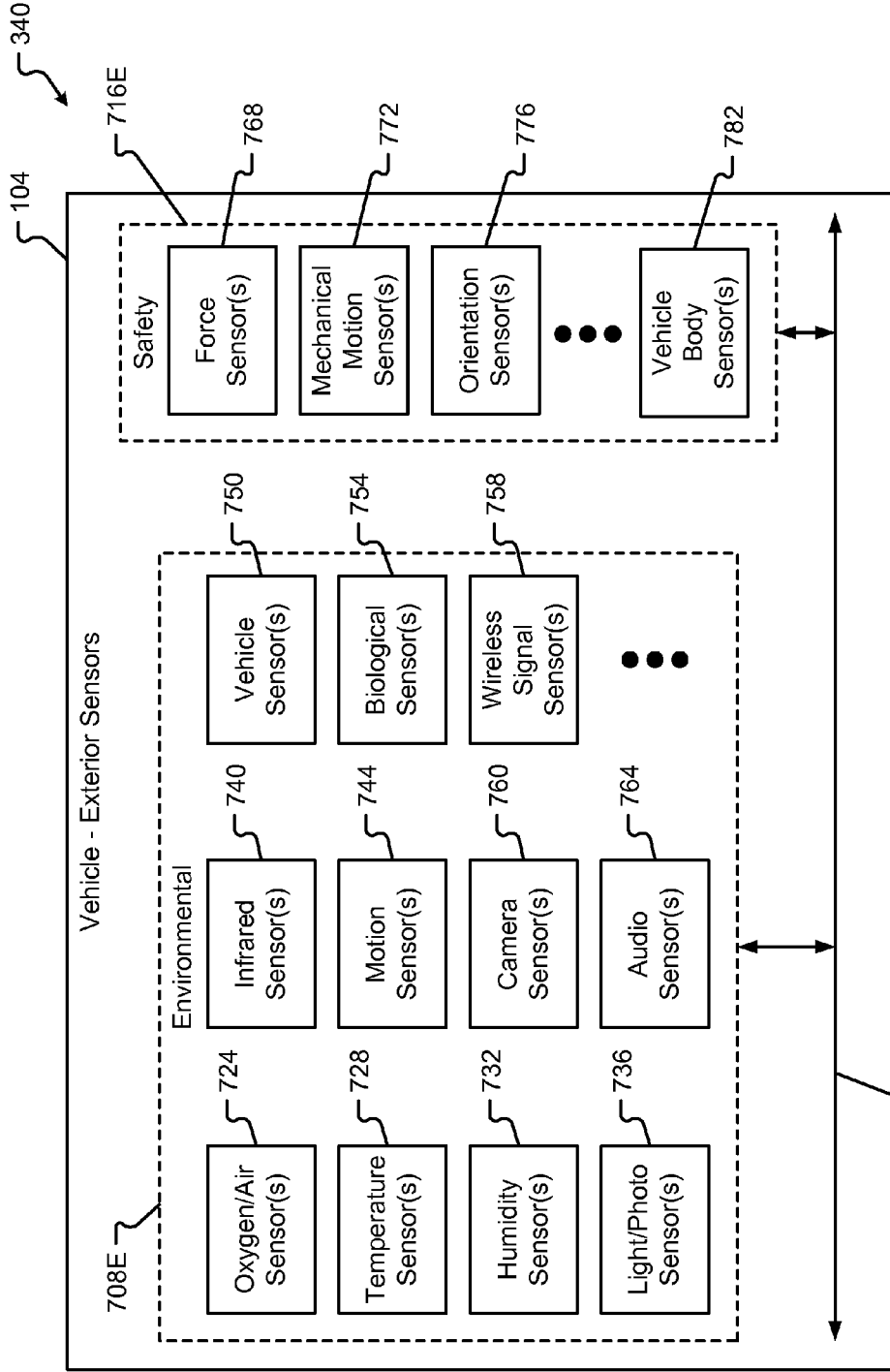

Fig. 7B

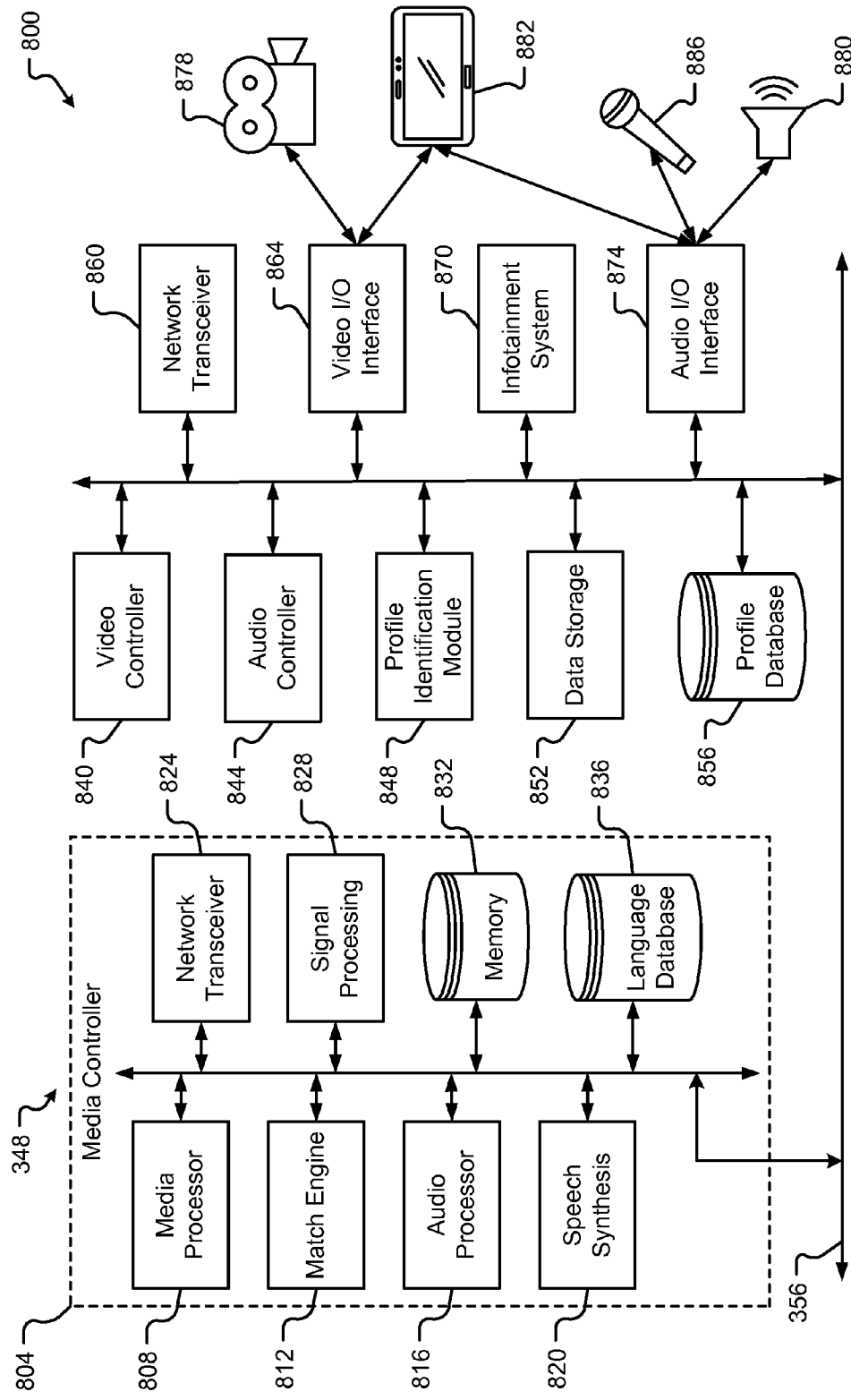

Fig. 8A

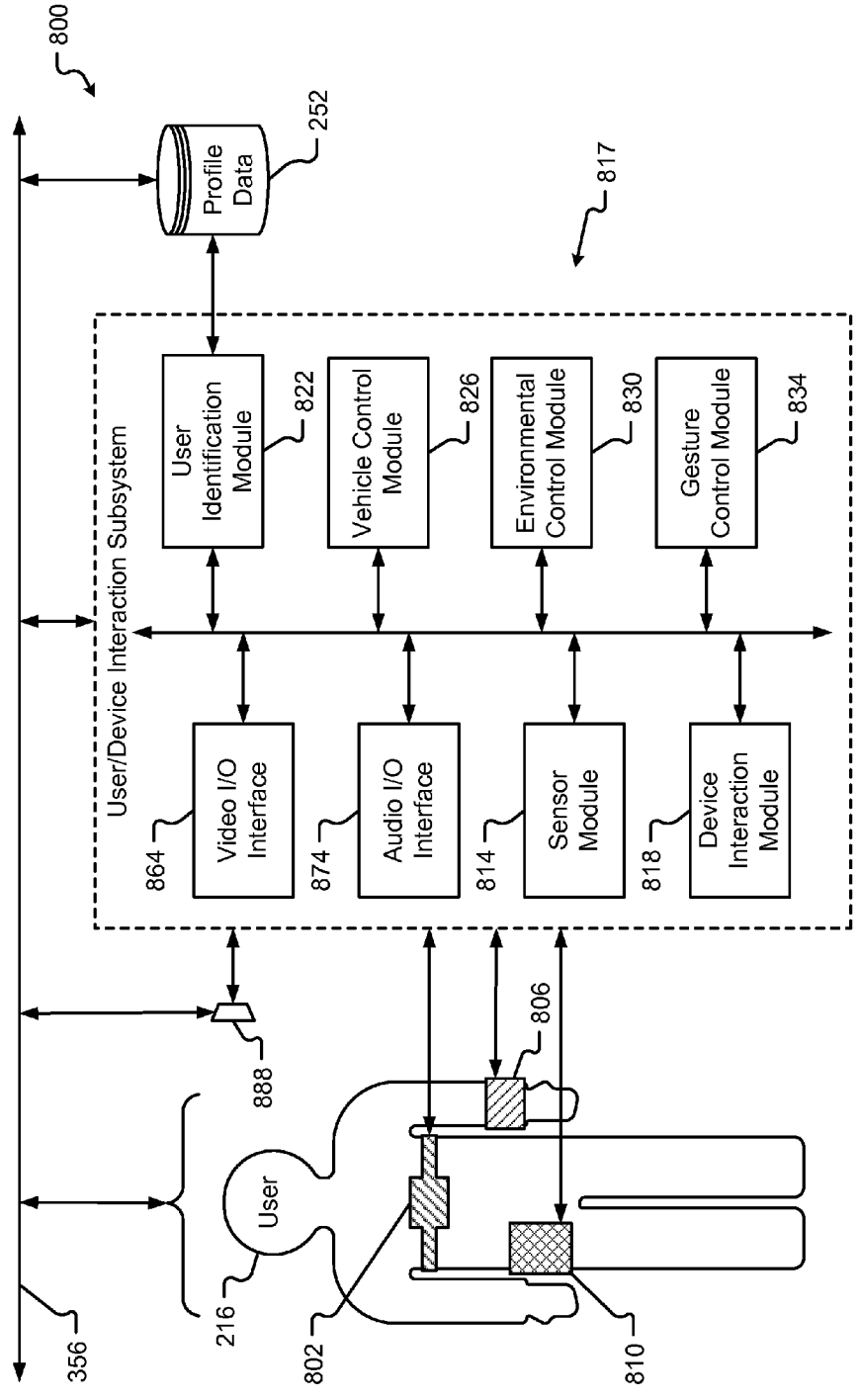

Fig. 8B

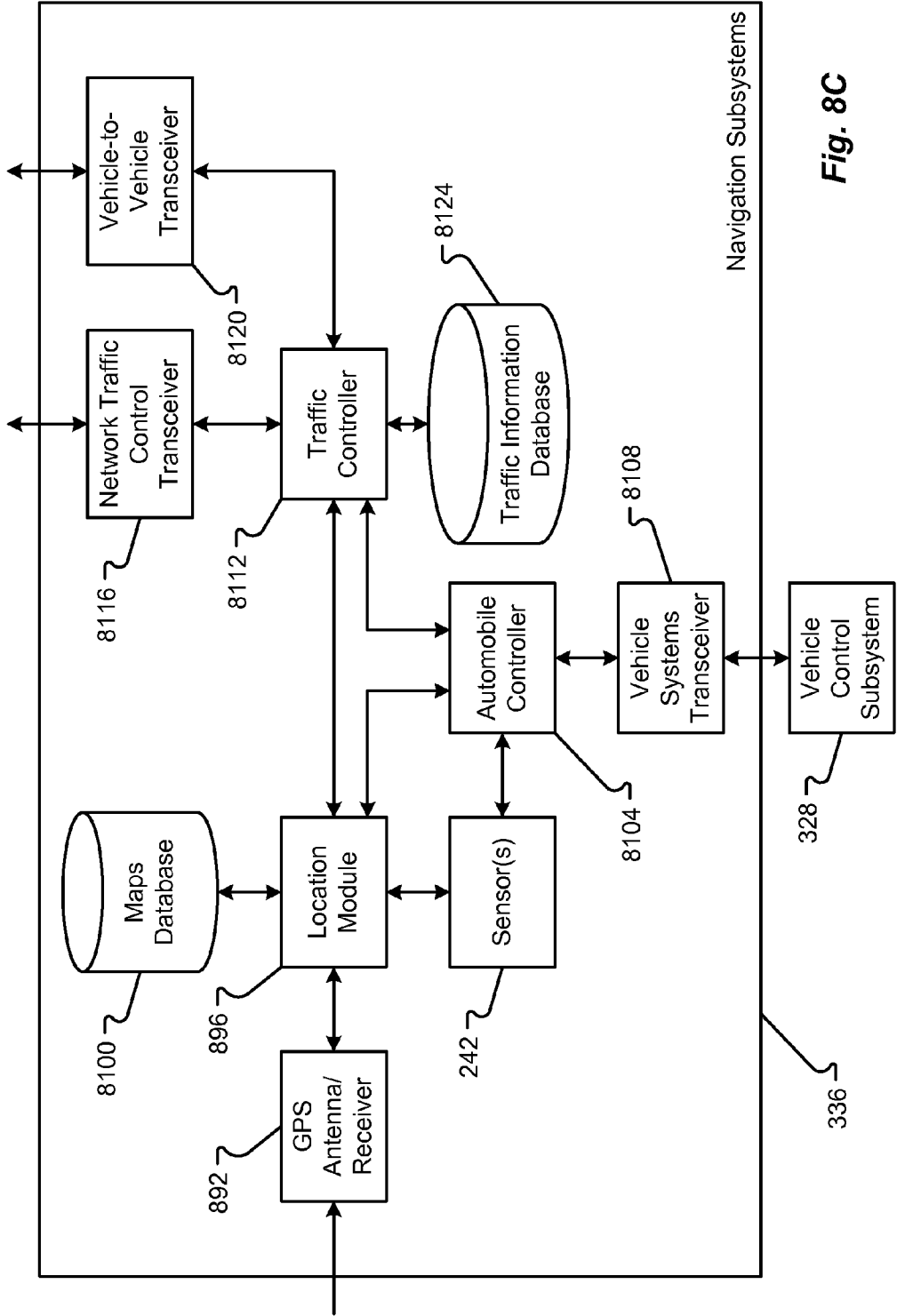

Fig. 8C

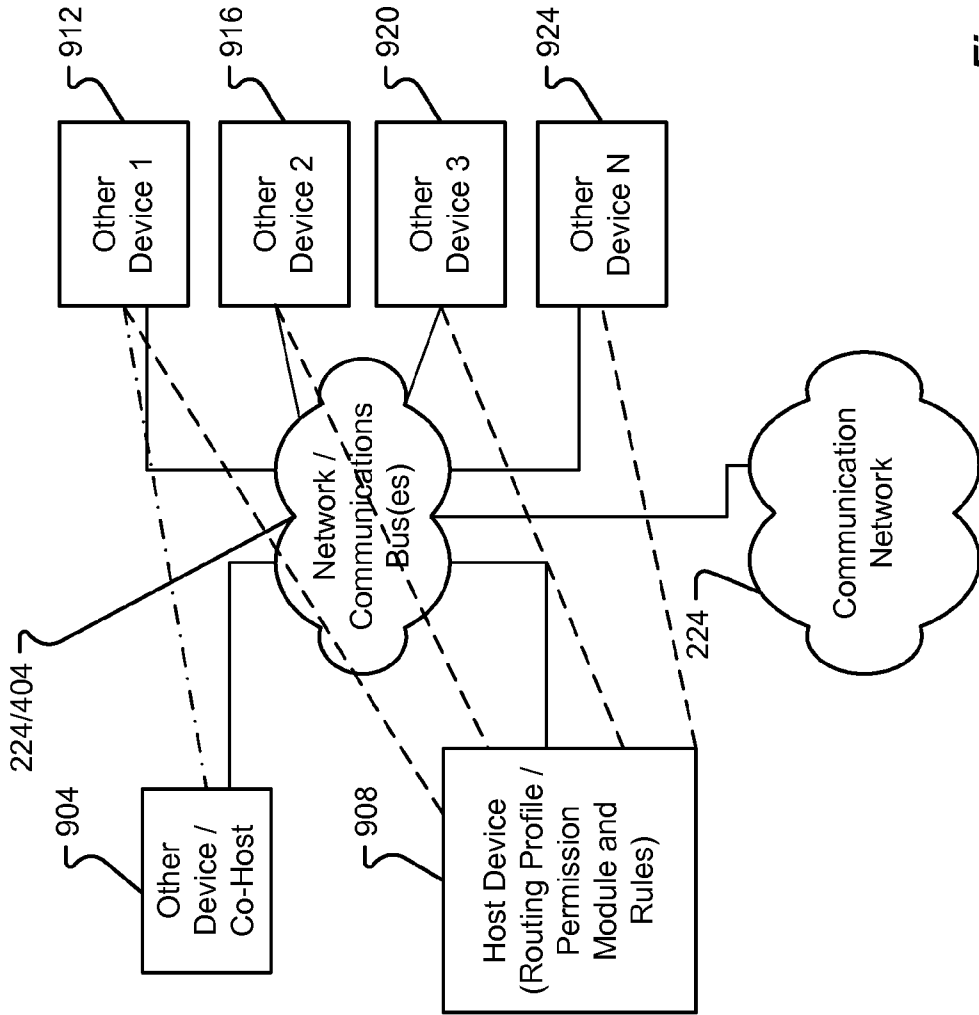

Fig. 9

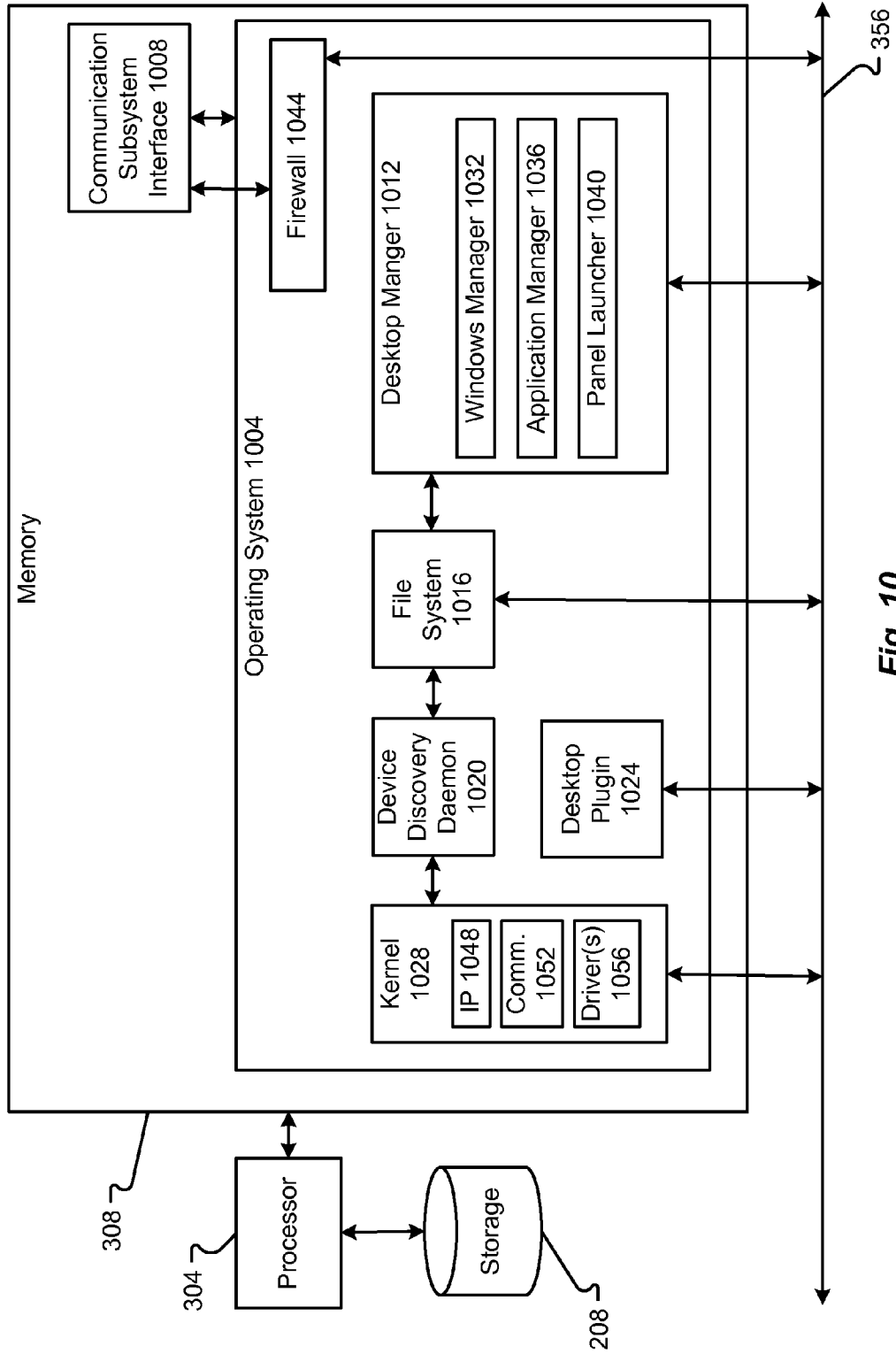
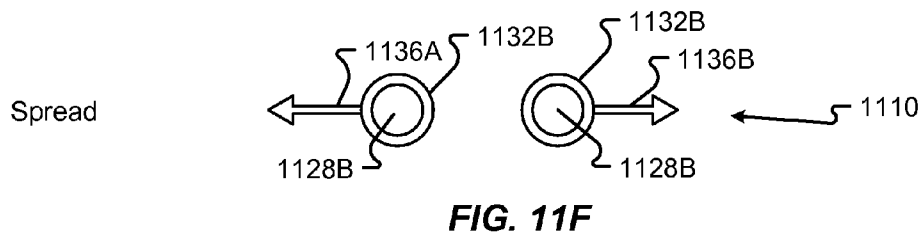
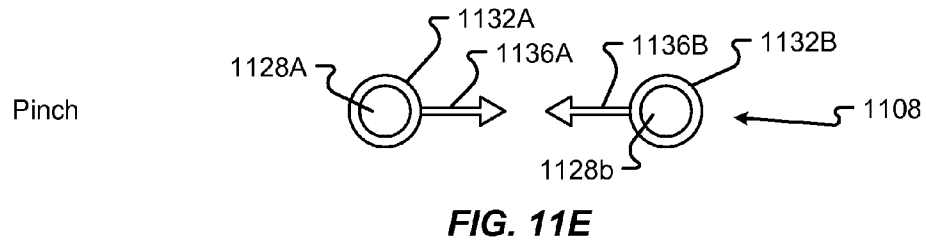
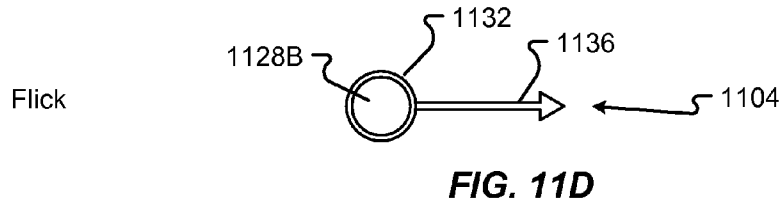
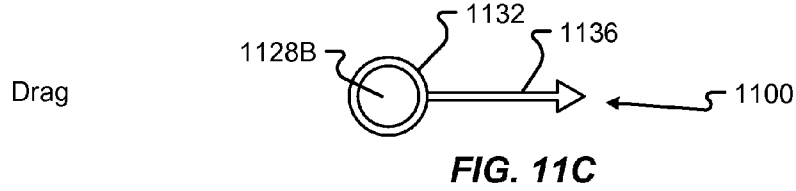
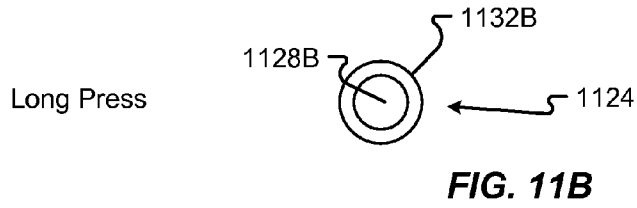
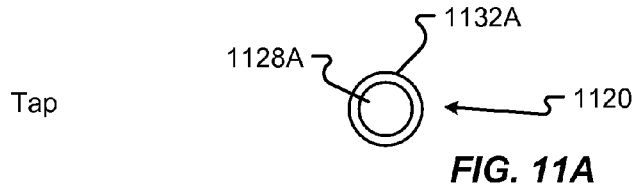

Fig. 10



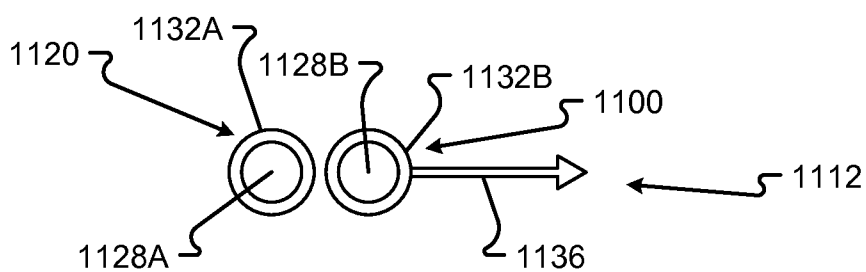

FIG. 11G

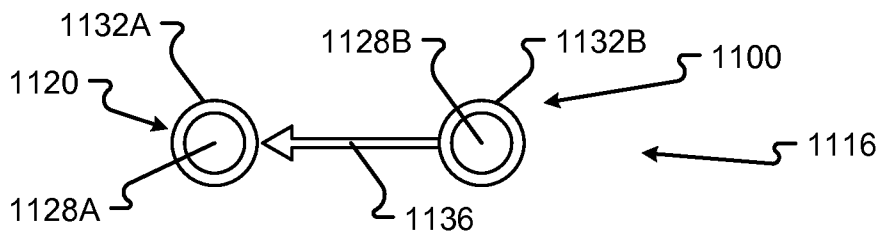

FIG. 11H

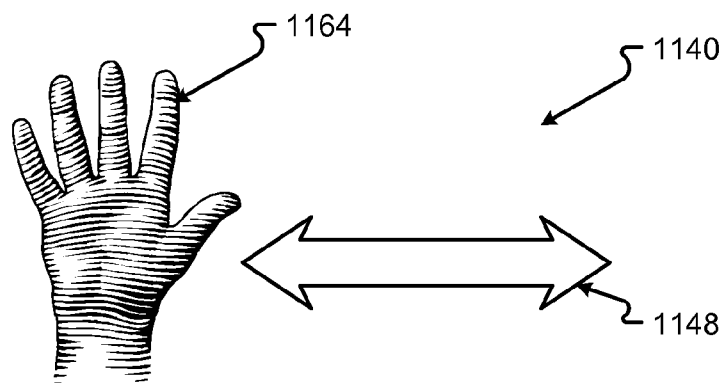

FIG. 11I

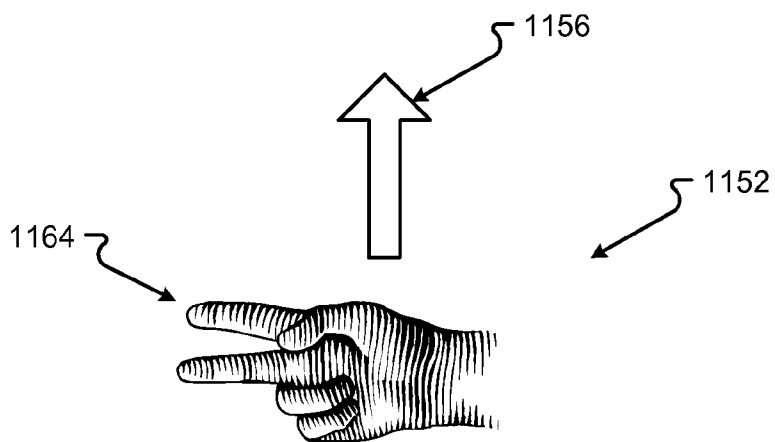

FIG. 11J

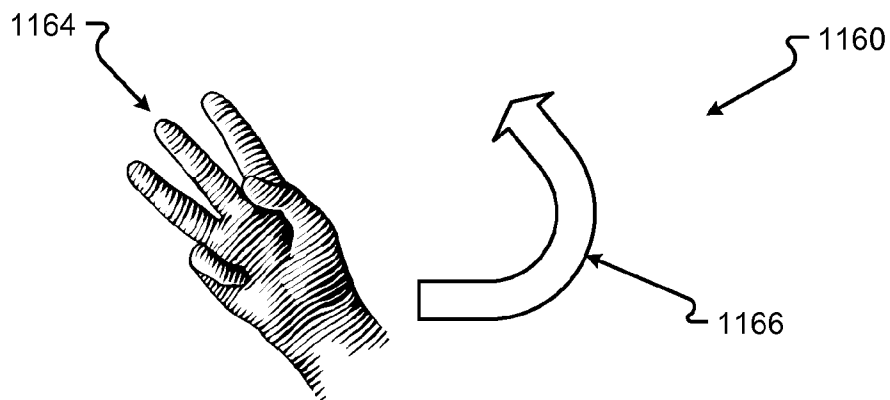

FIG. 11K

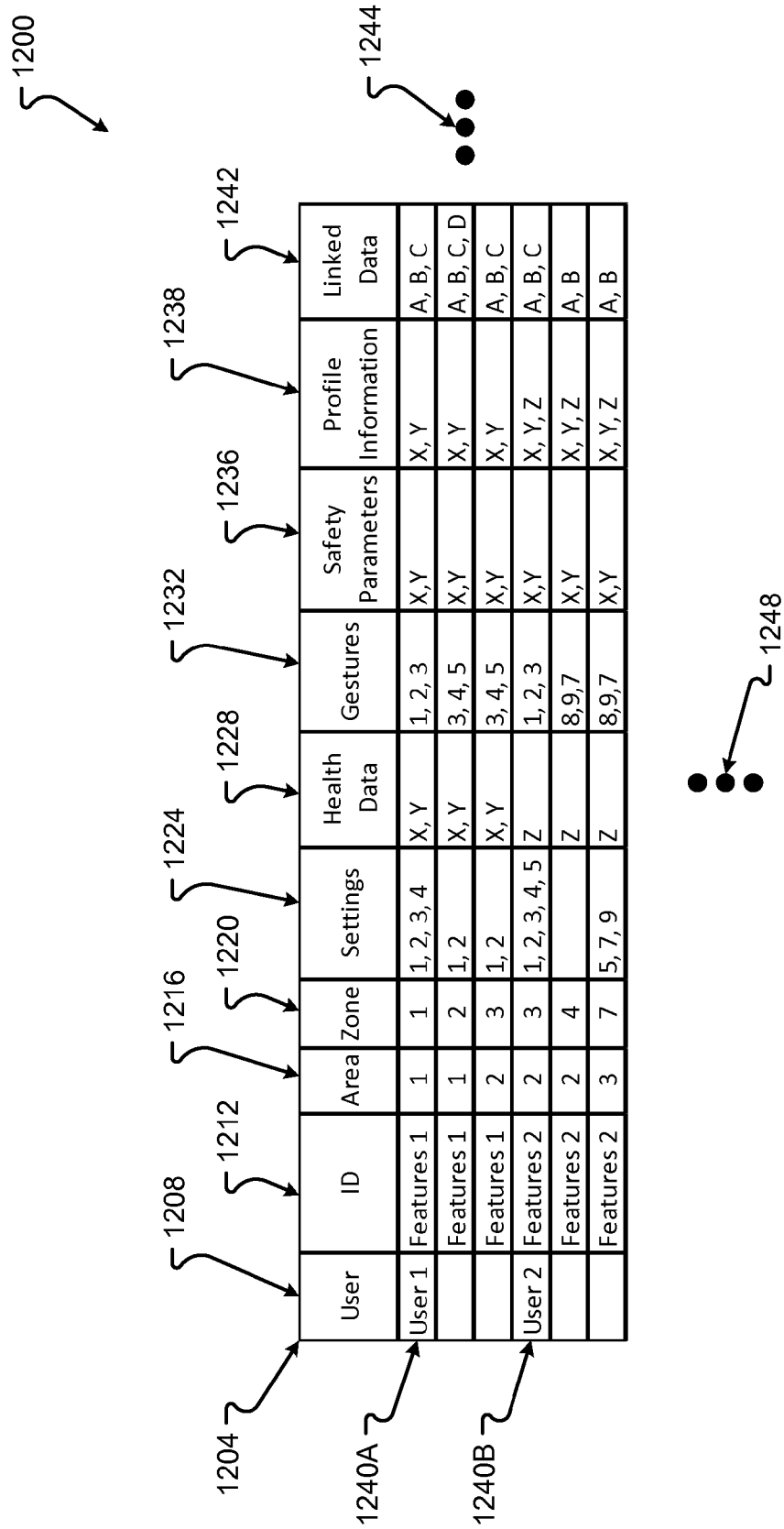

Fig. 12A

Device	User ID	Device ID	Area	Zone	Settings	Capabilities	Priority	Registration Data	Profile Information	Linked Data
Device 1	User 1	XYZ123	1	1	1, 2, 3	X, Y	A1	X11	X, Y	A, B, C
	User 2	XYZ123	1	2	1, 2, 3, 4	X, Y, Z	A2	X12	X, Y	A, C, D
	User 3	XYZ123	2	3	1, 2	X, Y, Z	B2	X13	X, Y	A, B, C
Device 2	User 1	ABC456	2	3	1, 2, 3, 4, 5	Z	A1	X21	X, Y, Z	A, B
	User 4	ABC456	2	4		Z			X, Y, Z	A, B
	User 6	ABC456	3	7	5, 7, 9	Z	C3	X22	X, Y, Z	A, B, C

Fig. 12B

Vehicle System	Component ID	Priority Type	Area	Zone	Settings	Health Status	Communication Type(s)	Profile Information	Linked Data
System 1	Component 1	C	1	1	1, 2	X, Y	W1, W2, W3	Y	A, B
	Component 2	NC	1	2	1	X, Y	W2, W3	X, Y	A, B, D
	Component 5	C	2	3	1, 2, 3	X	W1, W2		A, C
System 2	Component 3	C	2	3	1, 2, 3, 4	X, Y	W1	X, Y, Z	A, B
System 3	Component 7	NC	2	8	1, 3	X, Y, Z	W1, W2, W3, W4	X, Y, Z	A, B, C
	Component 8	NC	3	9	5, 8		W1, W2, W3	X	A, B

Fig. 12C

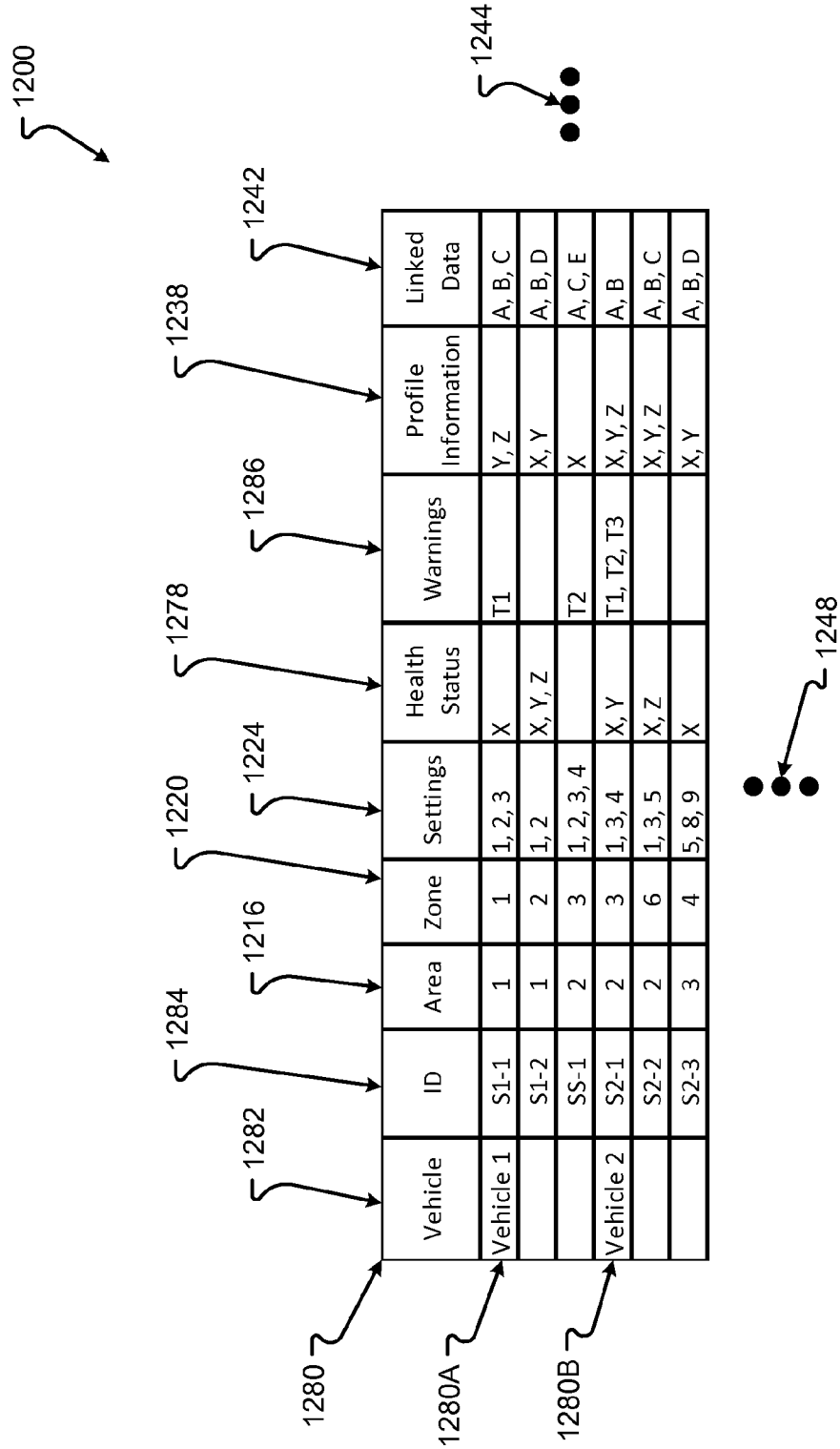

Fig. 12D

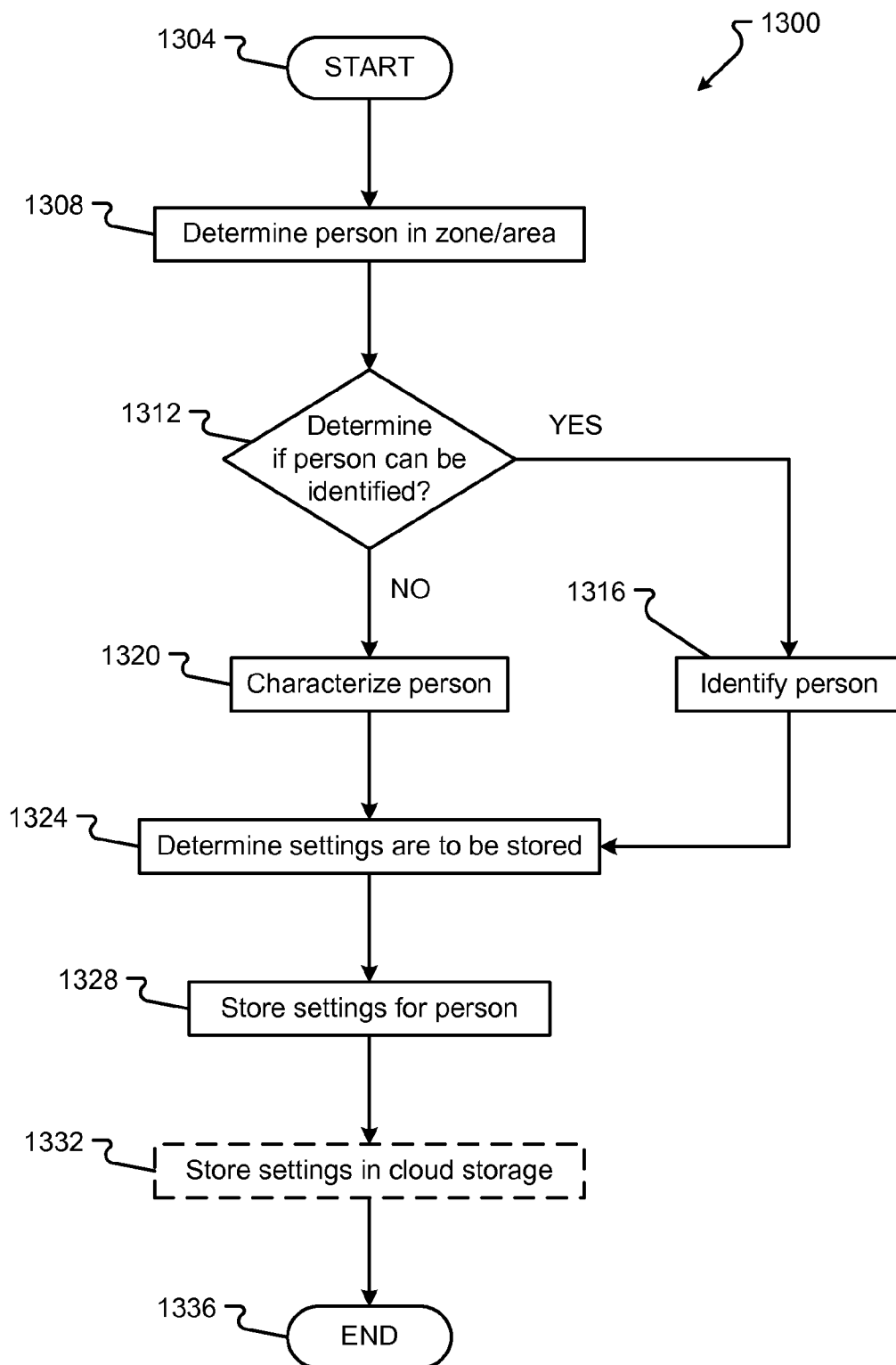

Fig. 13

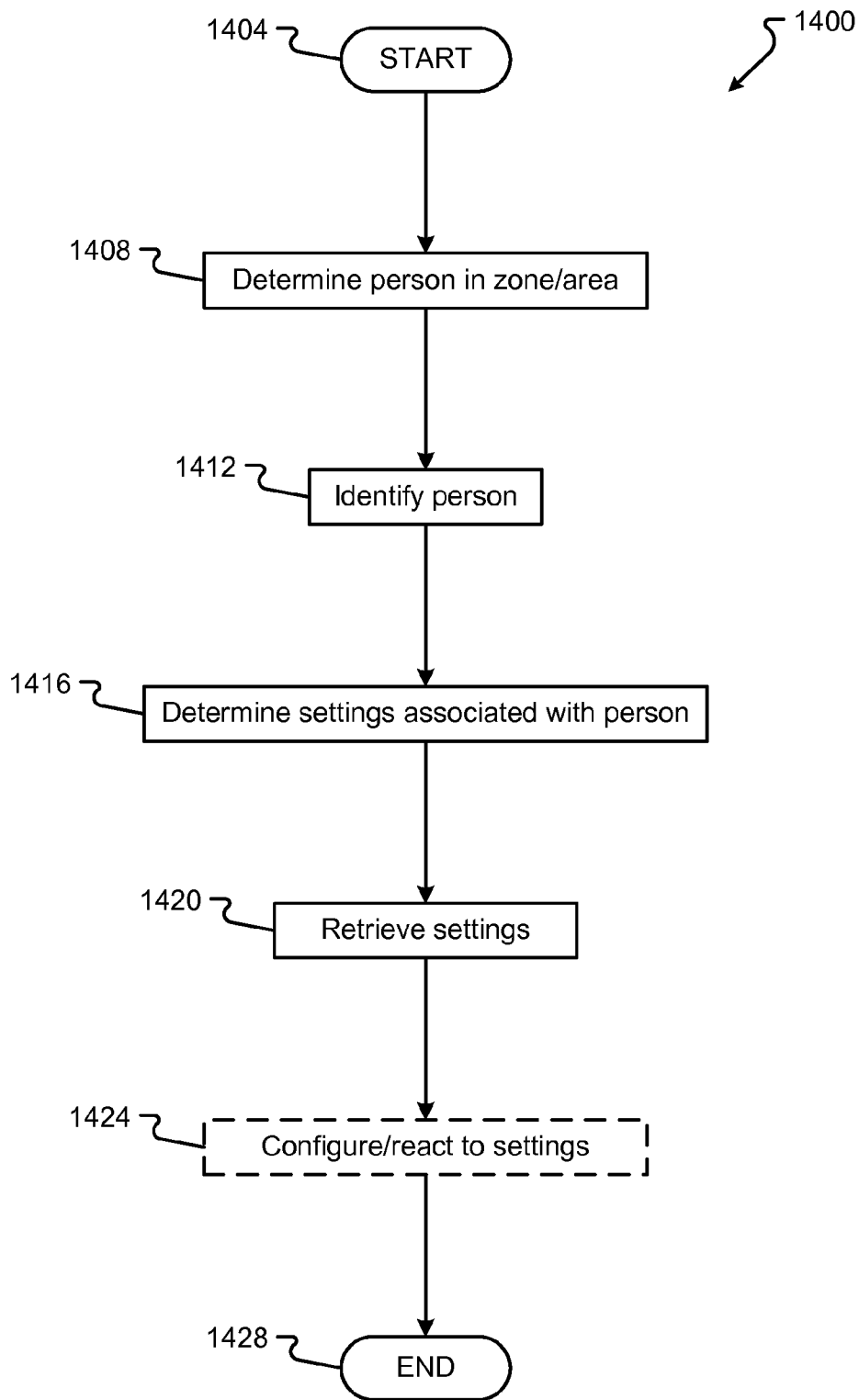

Fig. 14

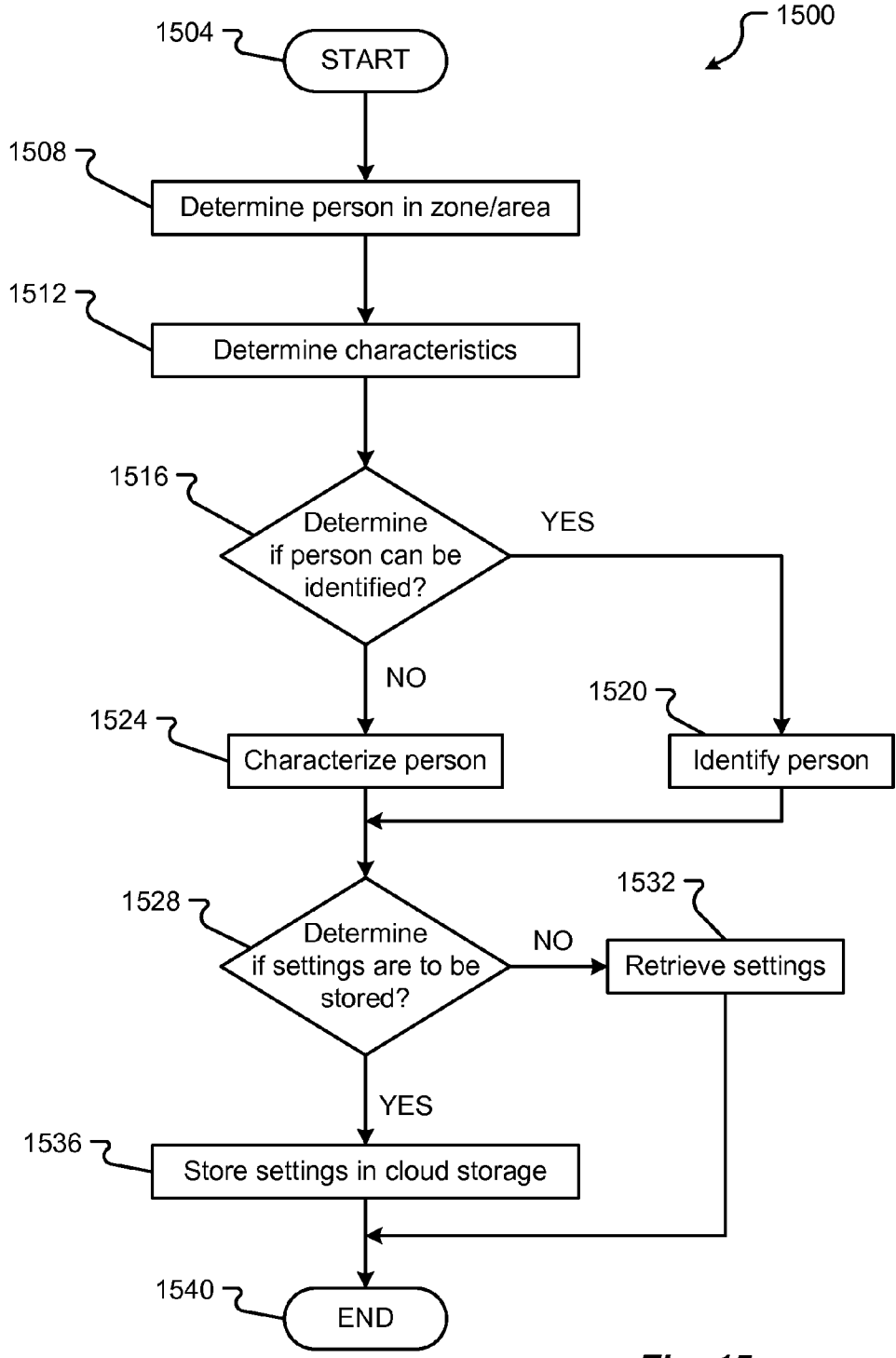

Fig. 15

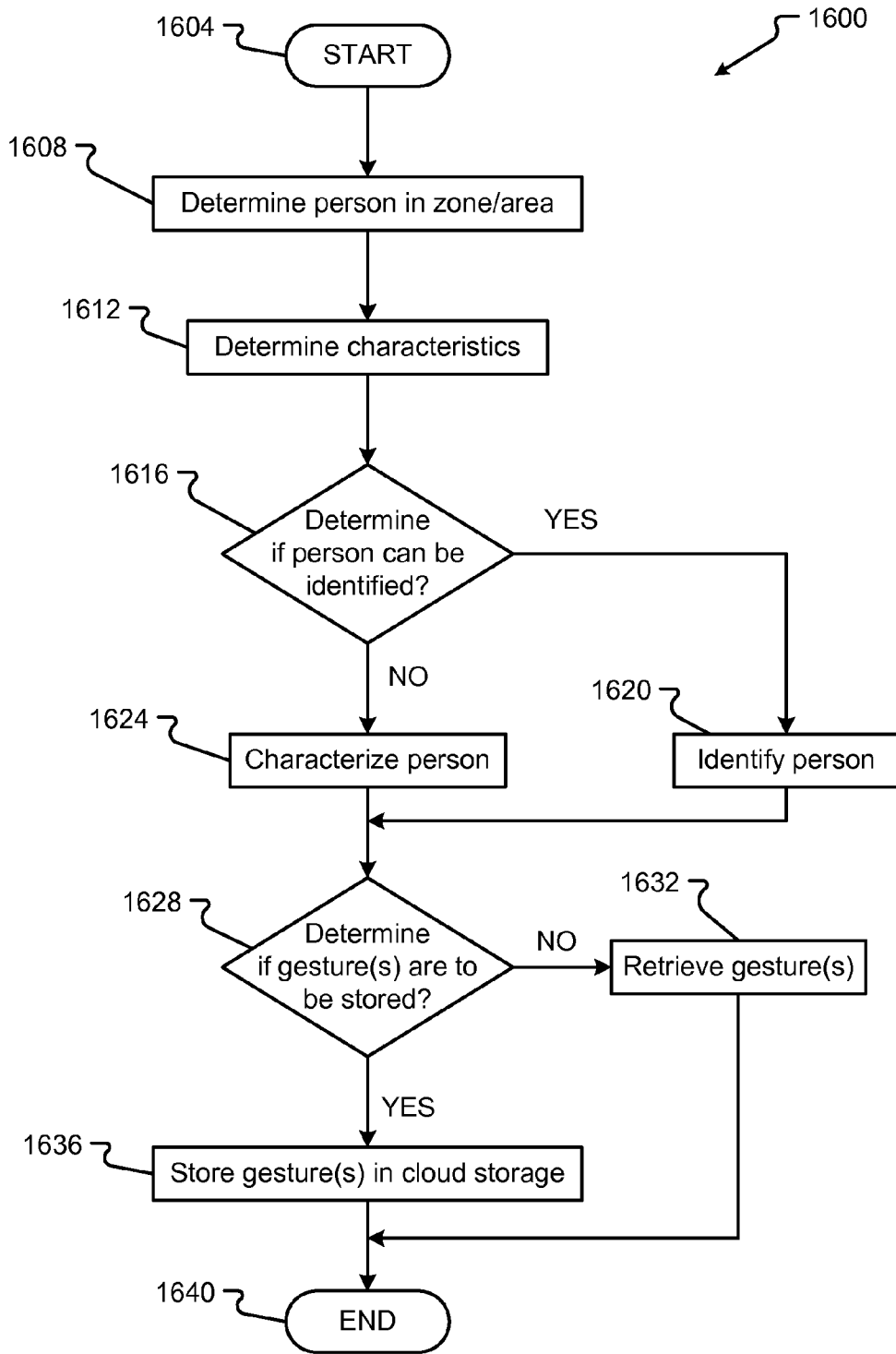

Fig. 16

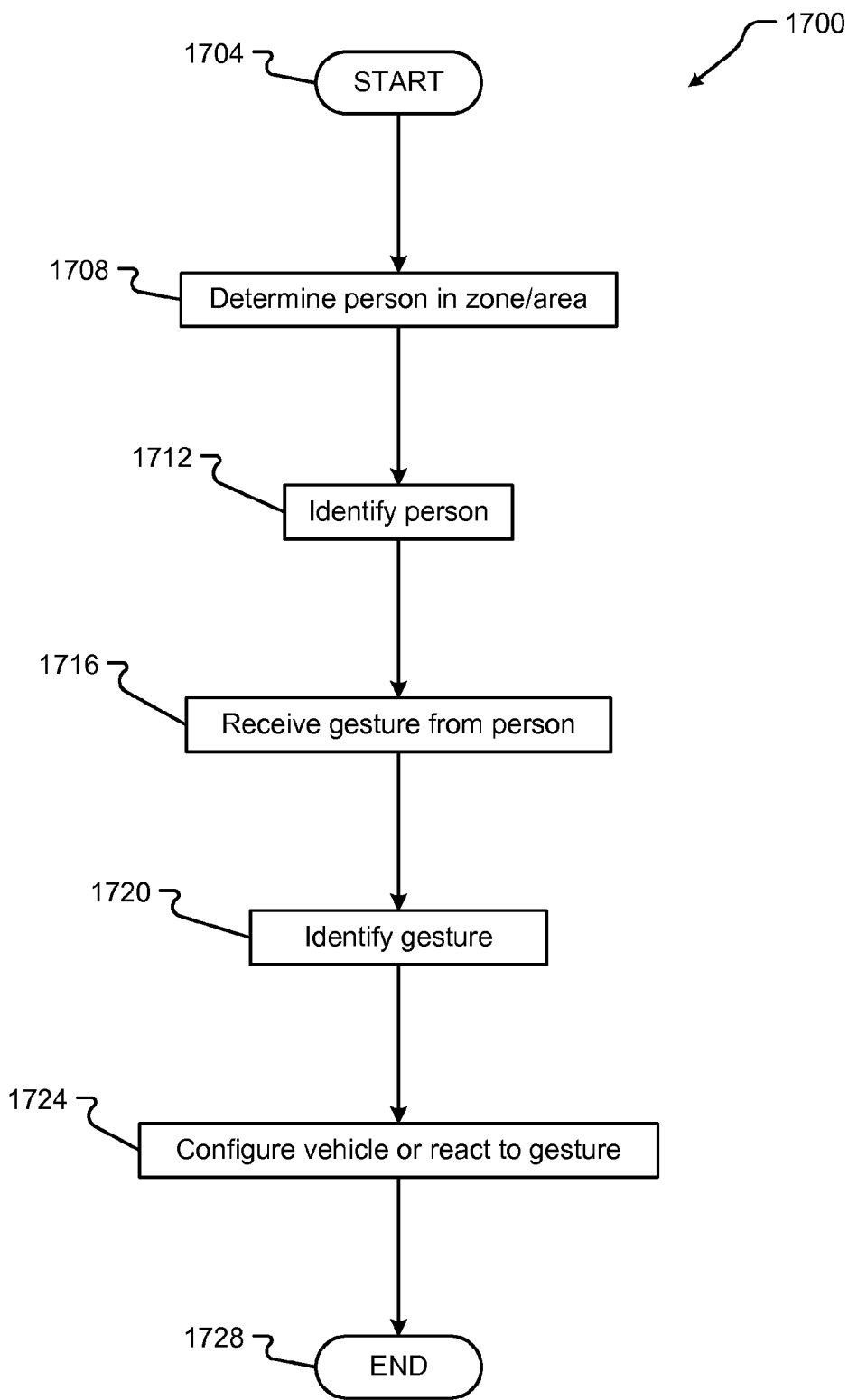

Fig. 17

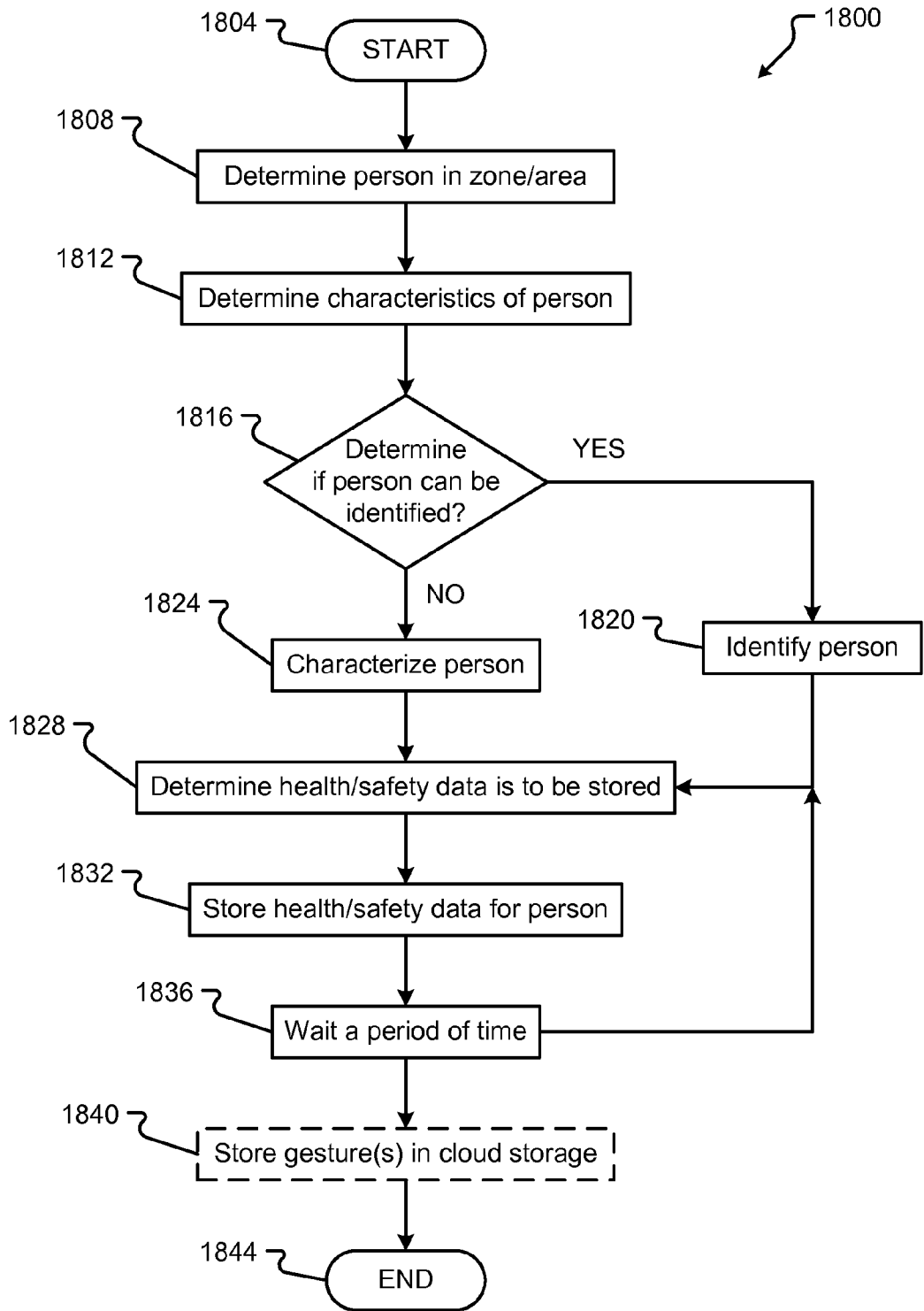

Fig. 18

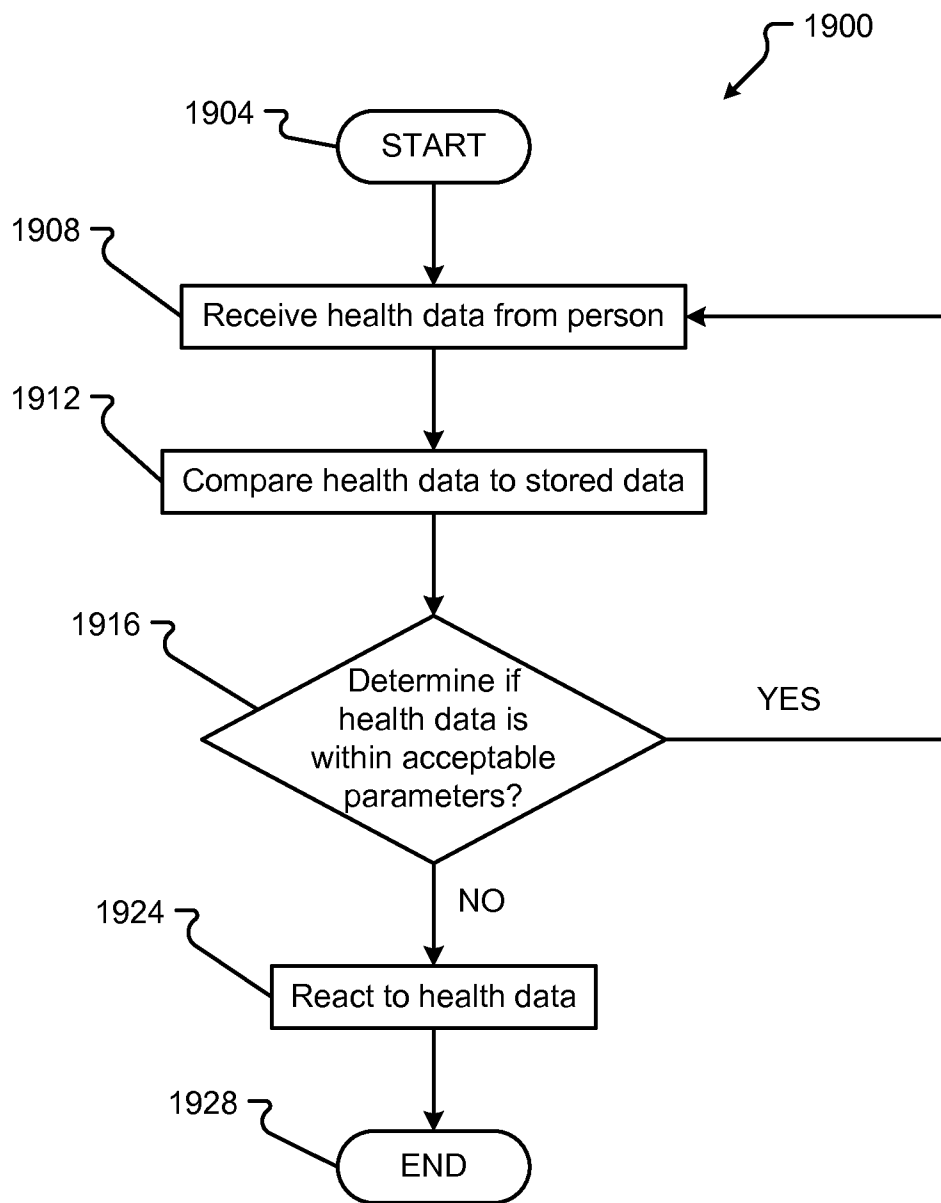

Fig. 19

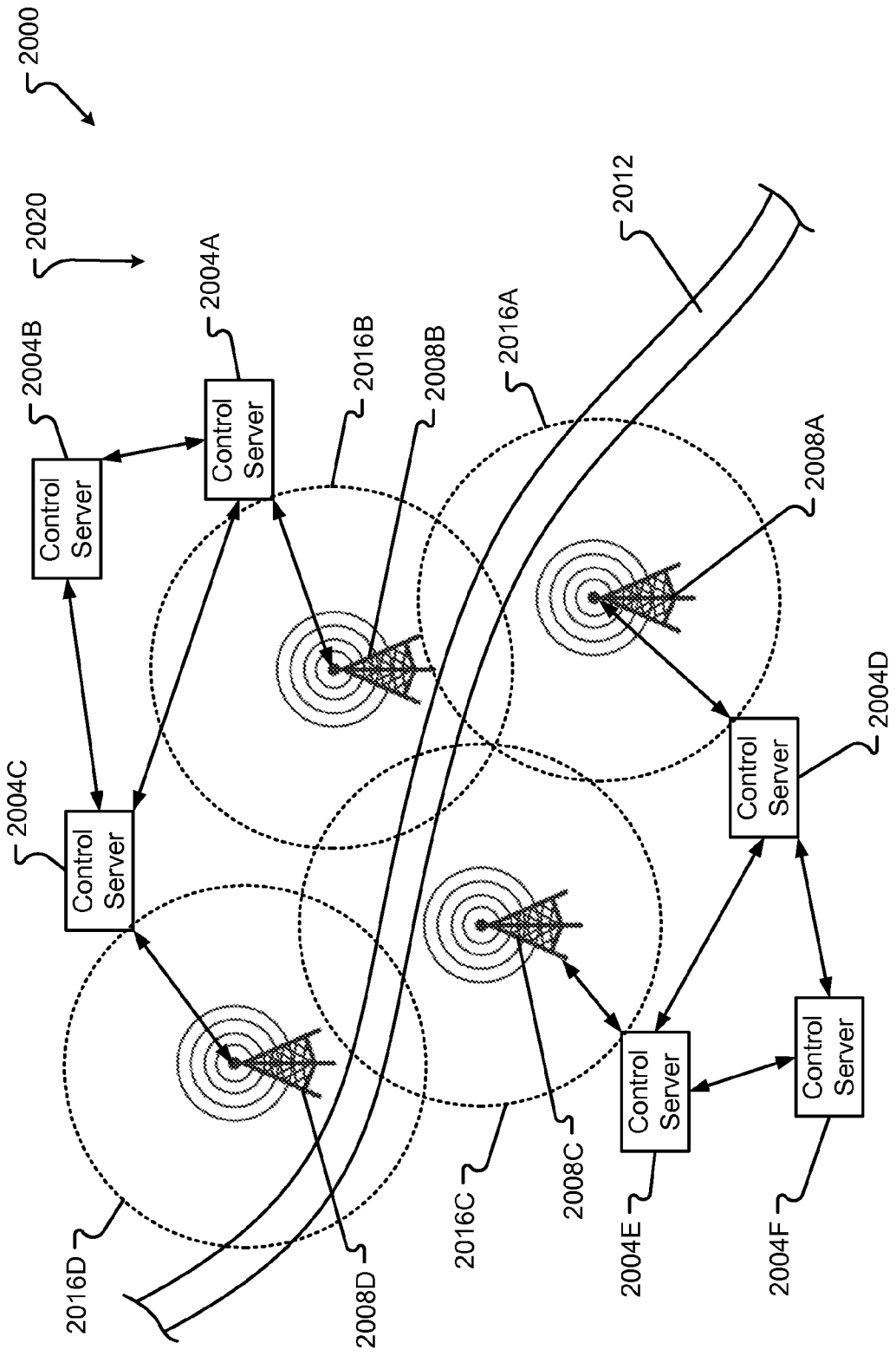

Fig. 20

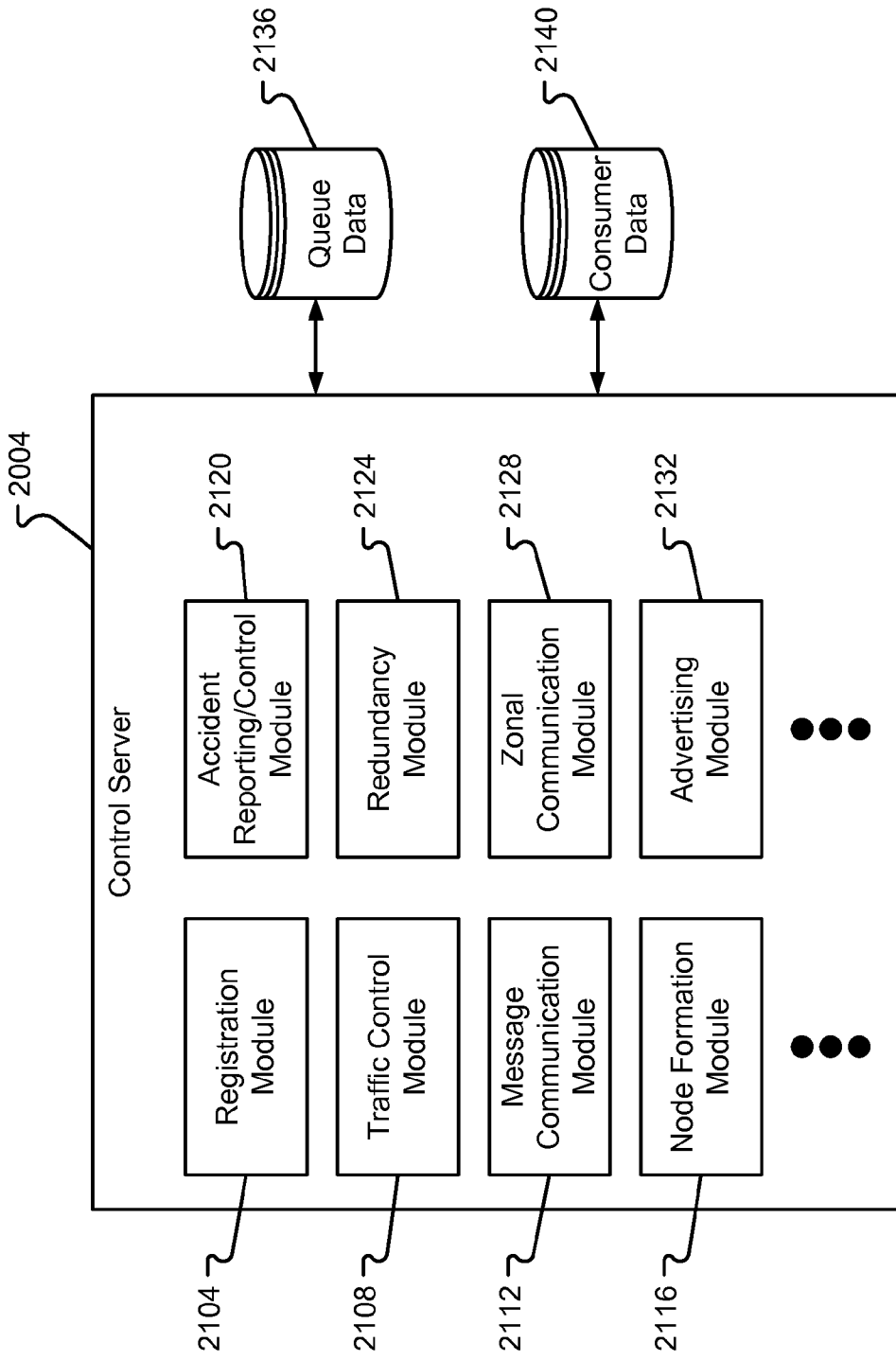

Fig. 21

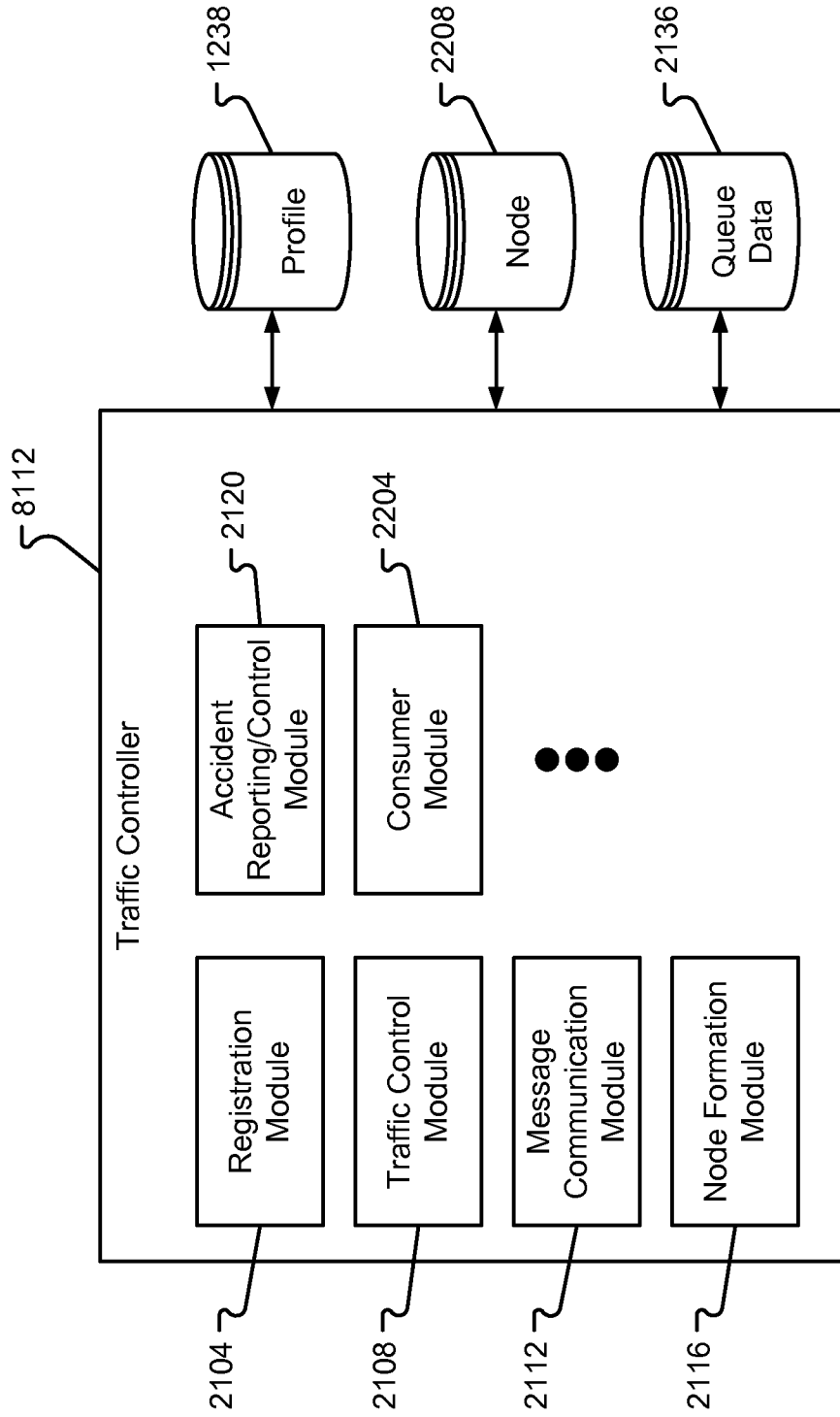

Fig. 22

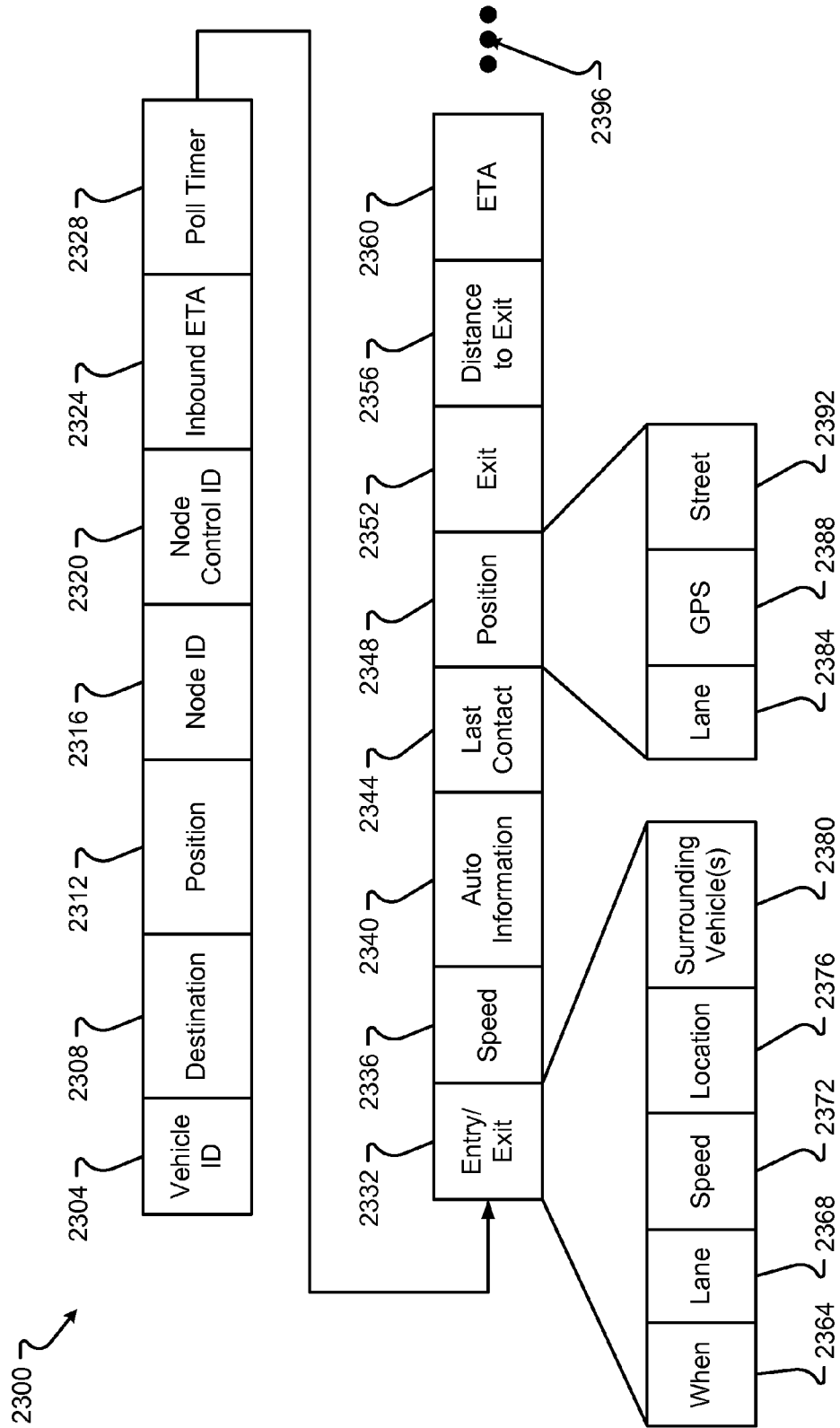

Fig. 23

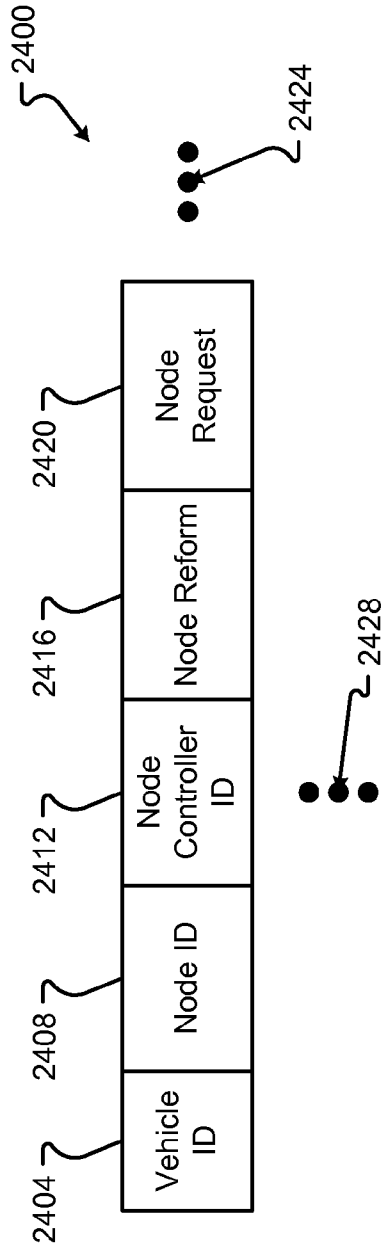

Fig. 24

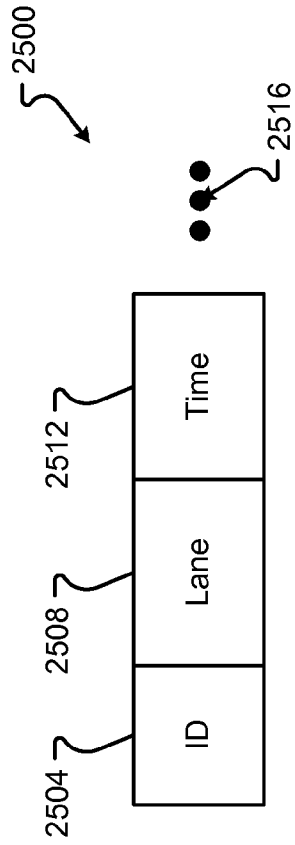

Fig. 25

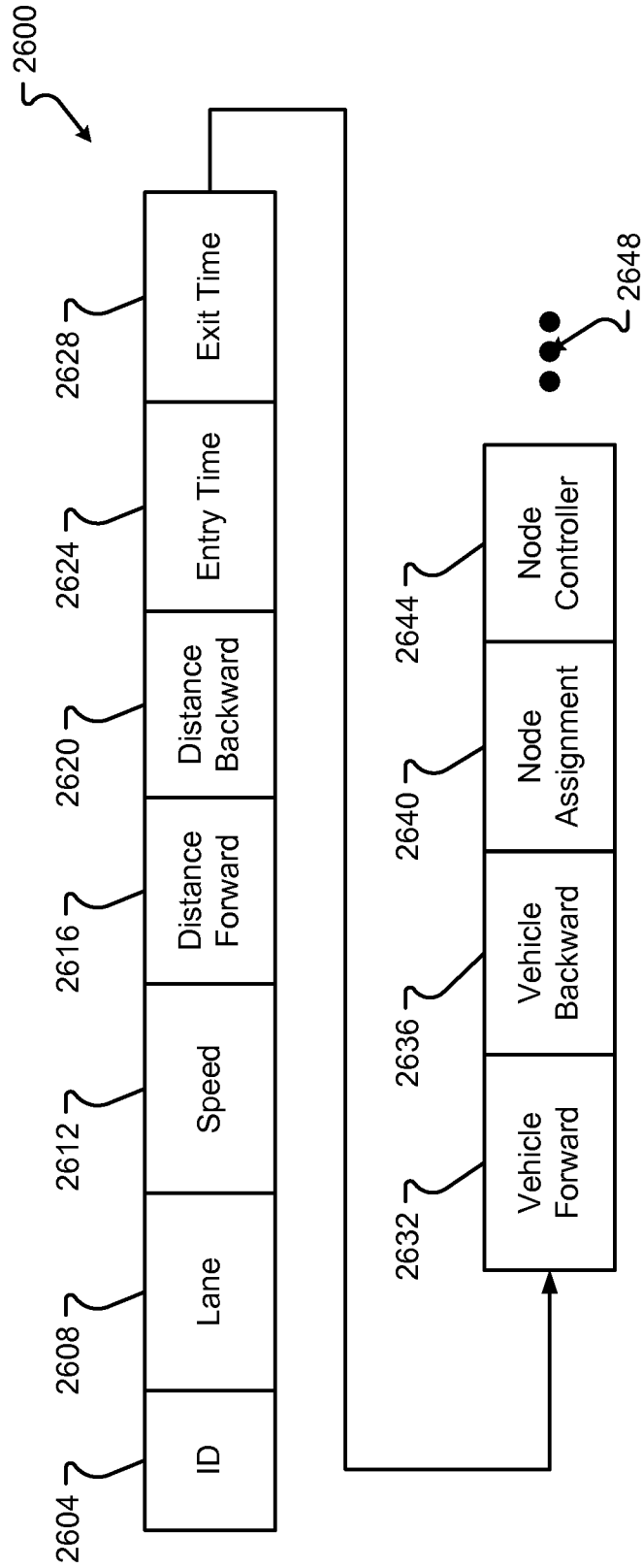

Fig. 26

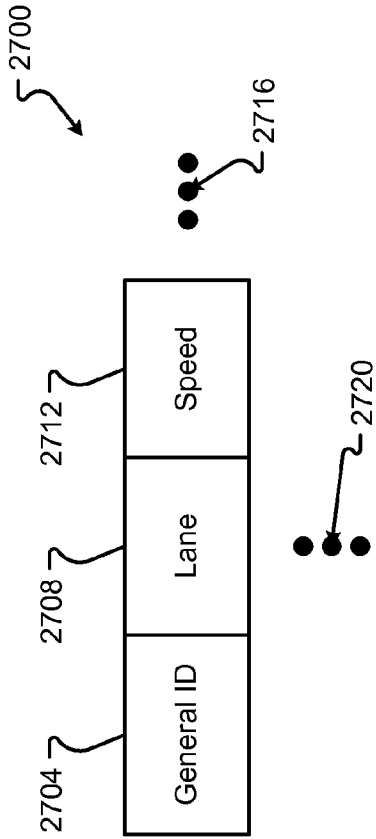

Fig. 27

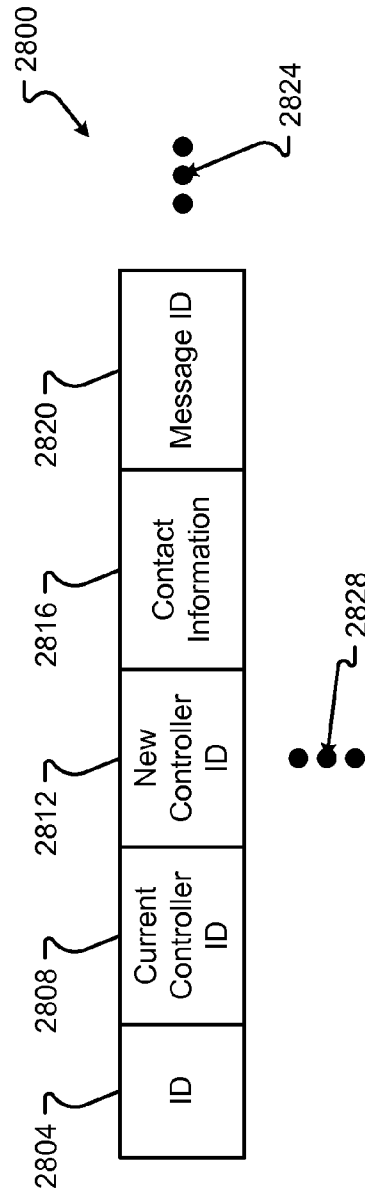

Fig. 28

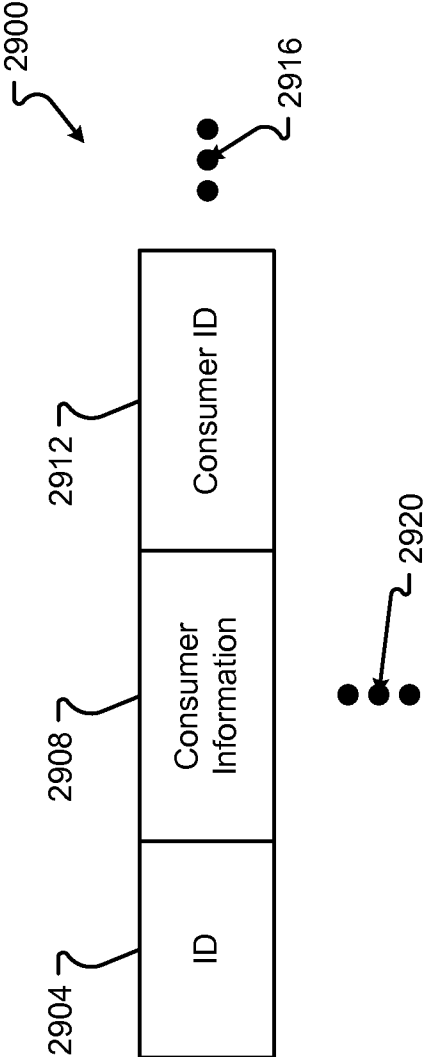

Fig. 29

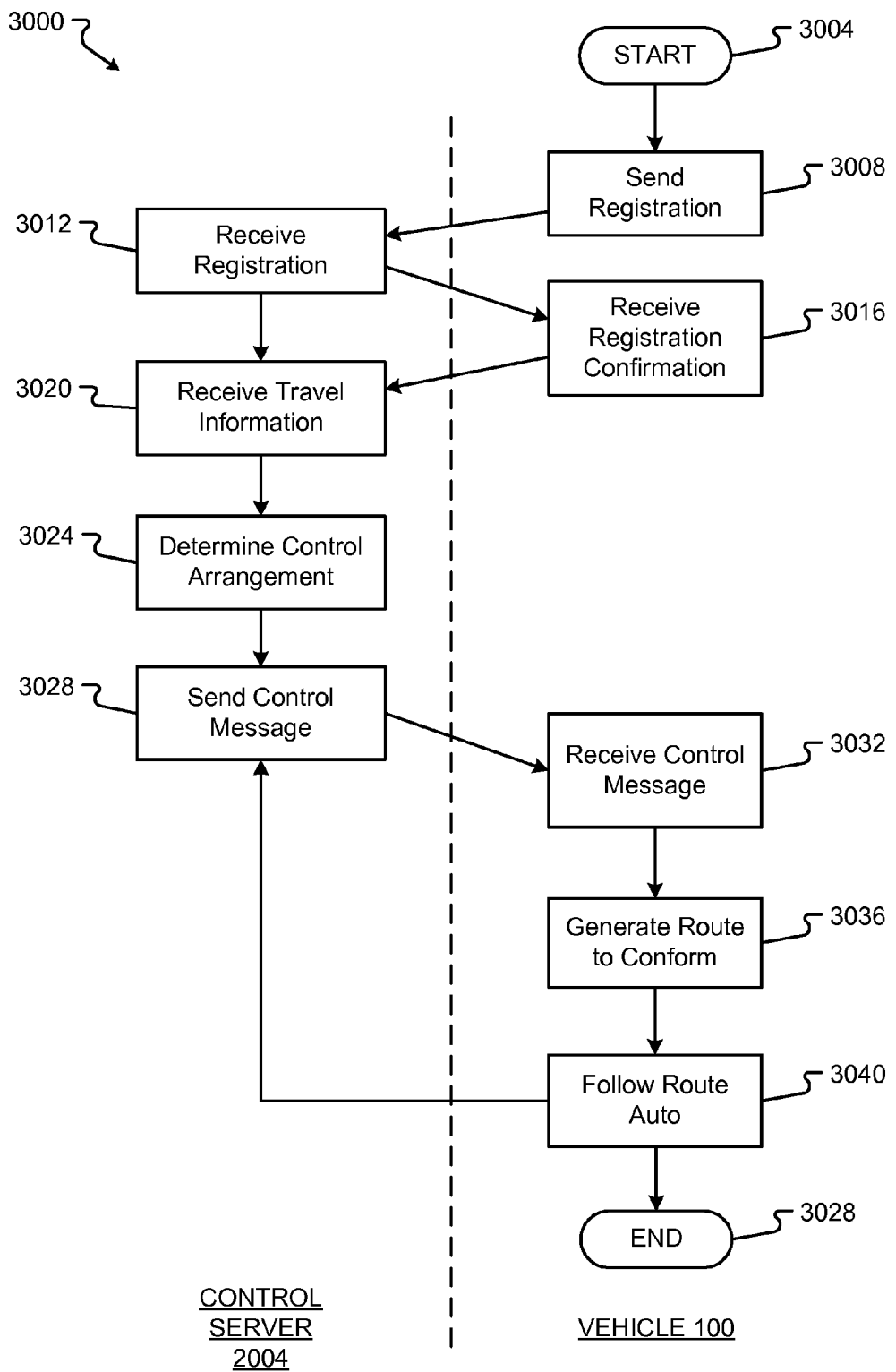

Fig. 30

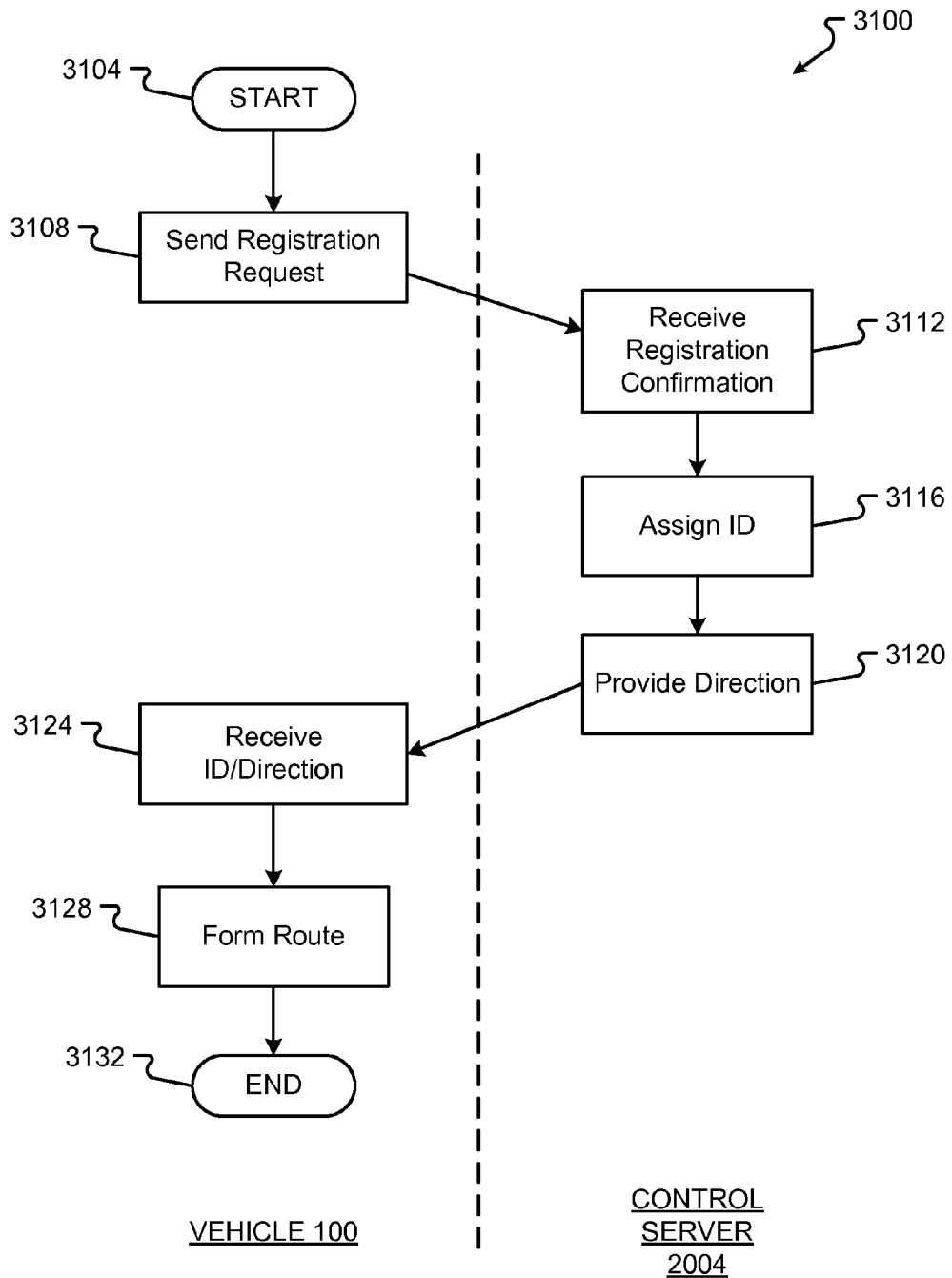

Fig. 31

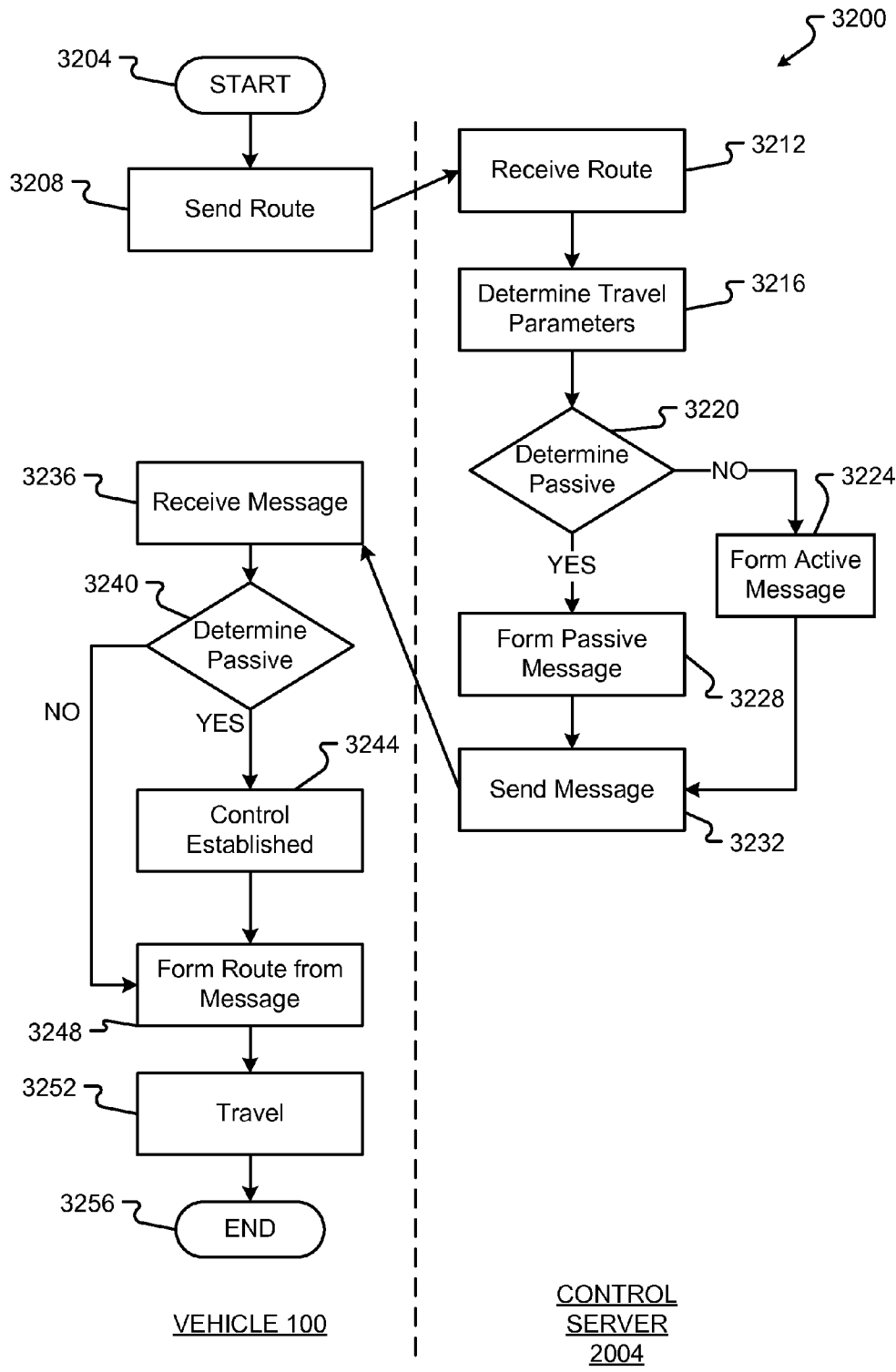

Fig. 32

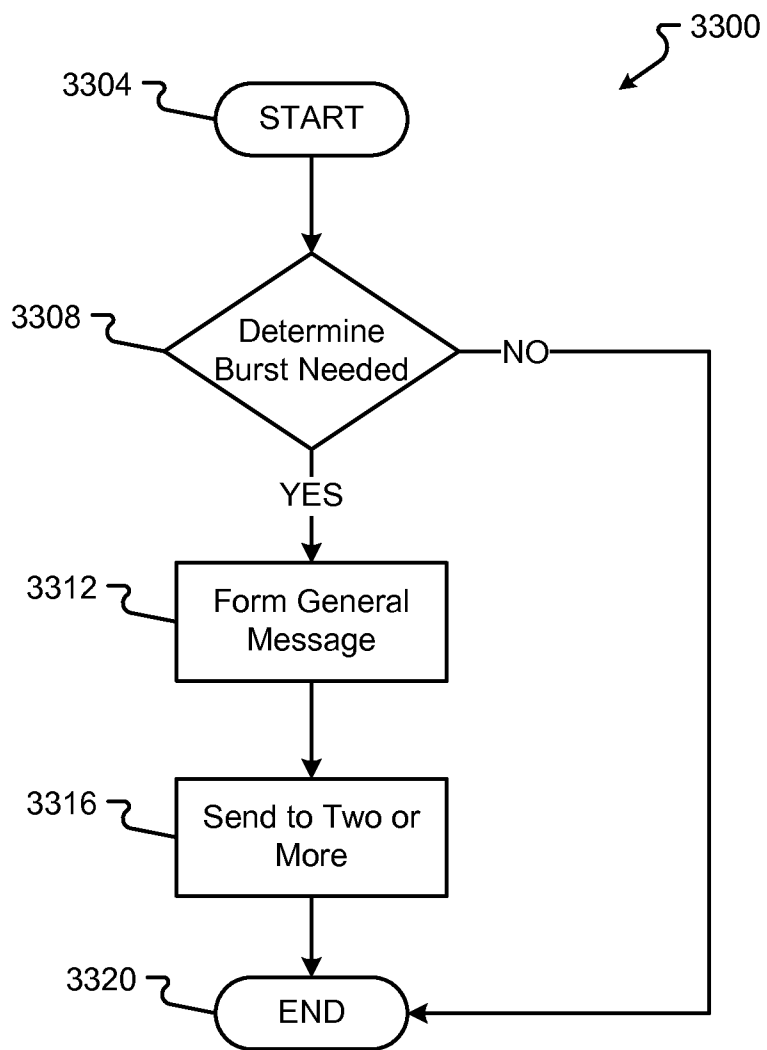

Fig. 33

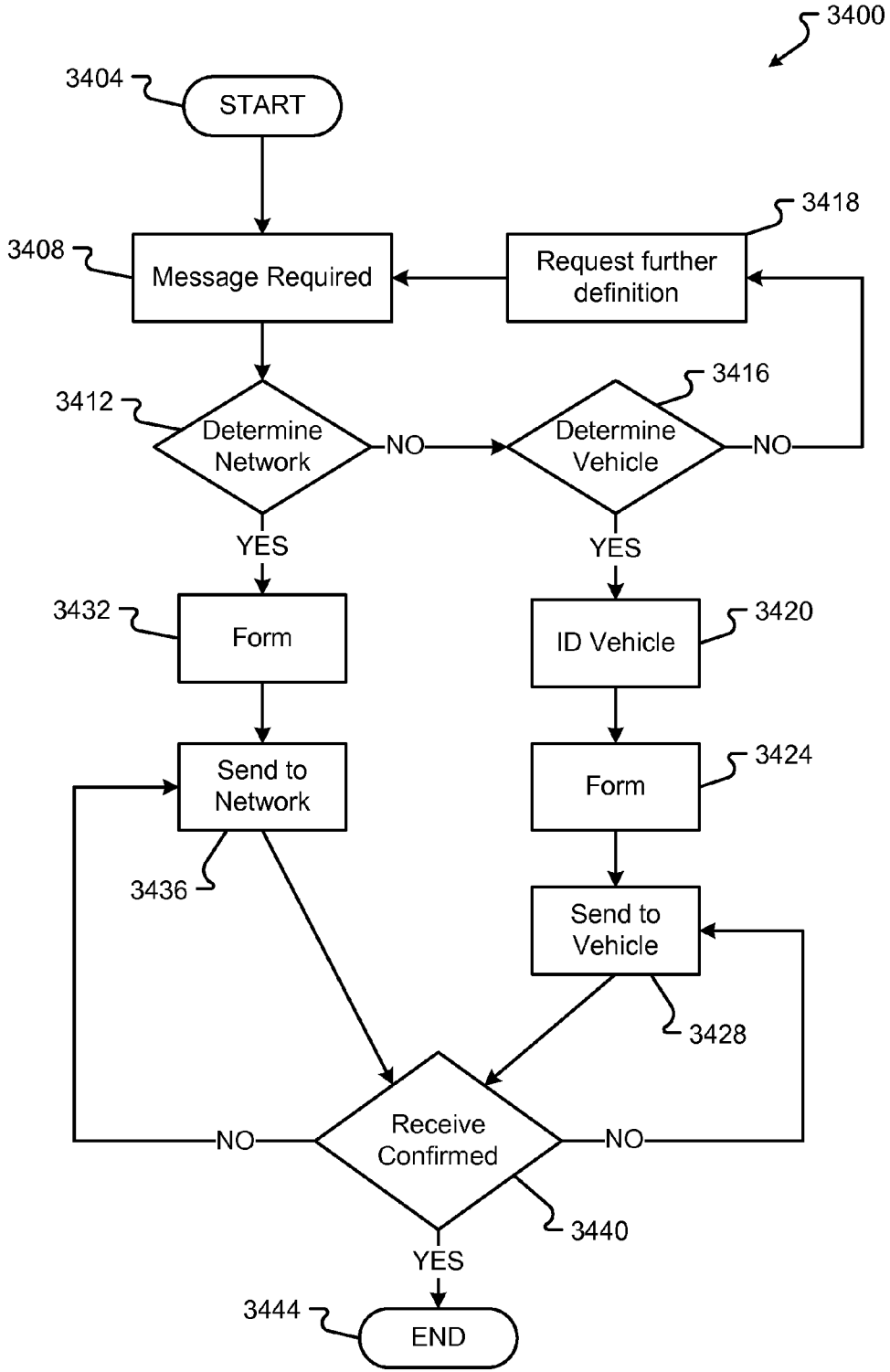

Fig. 34A

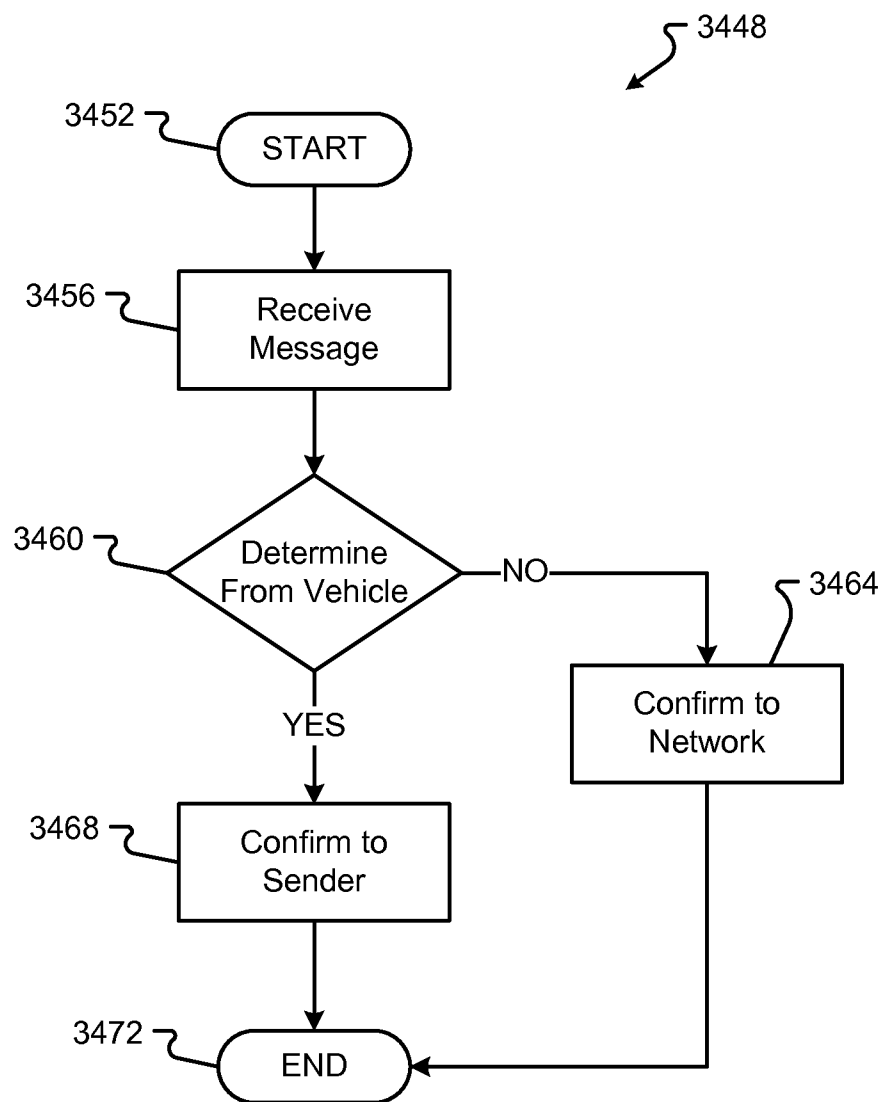

Fig. 34B

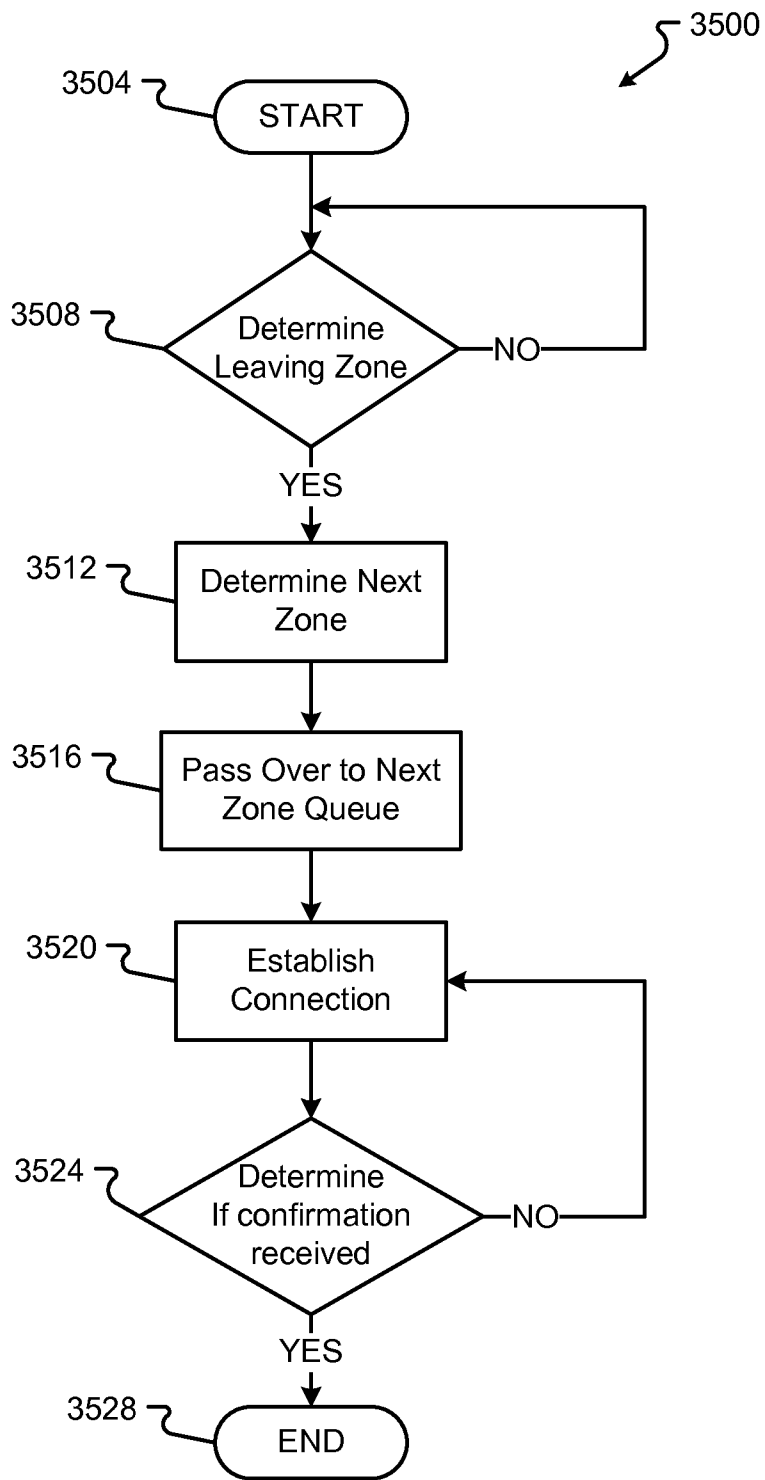

Fig. 35

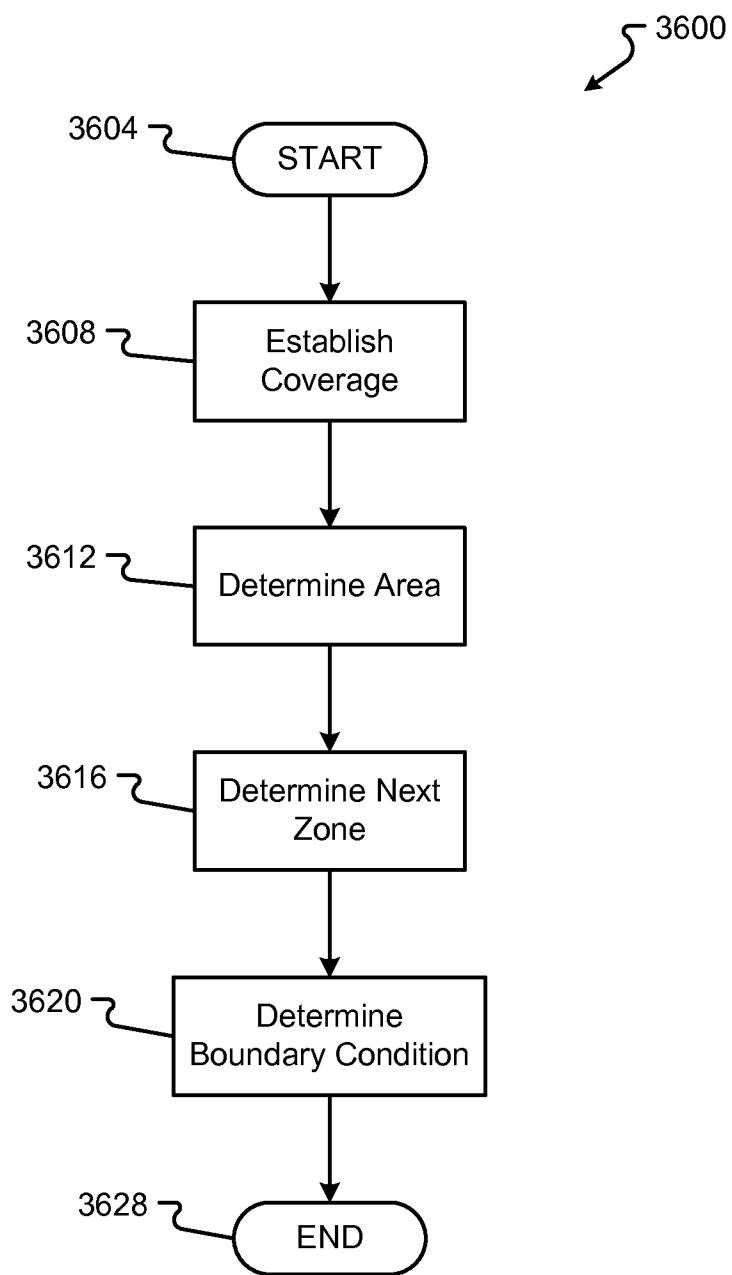

Fig. 36

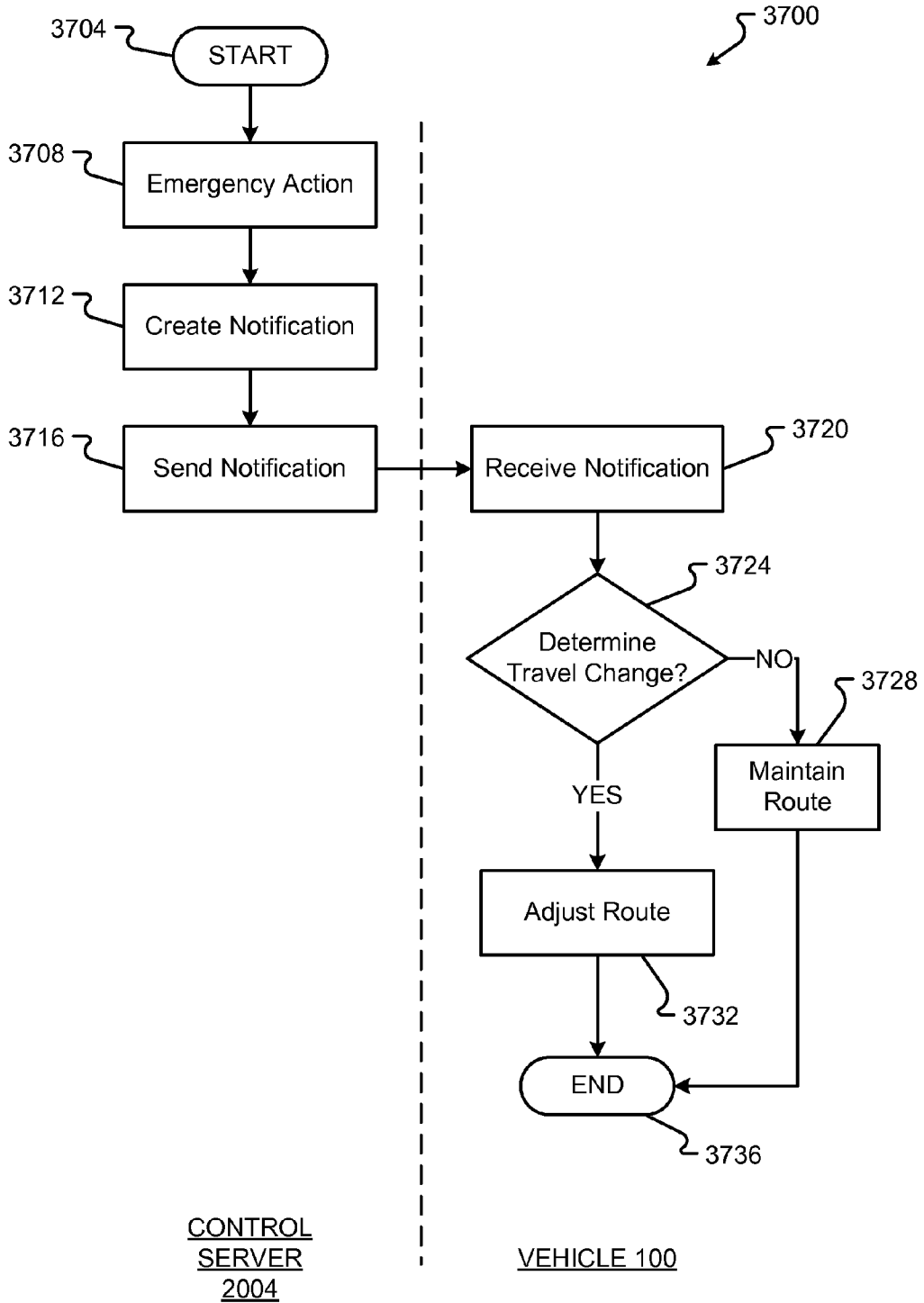

Fig. 37

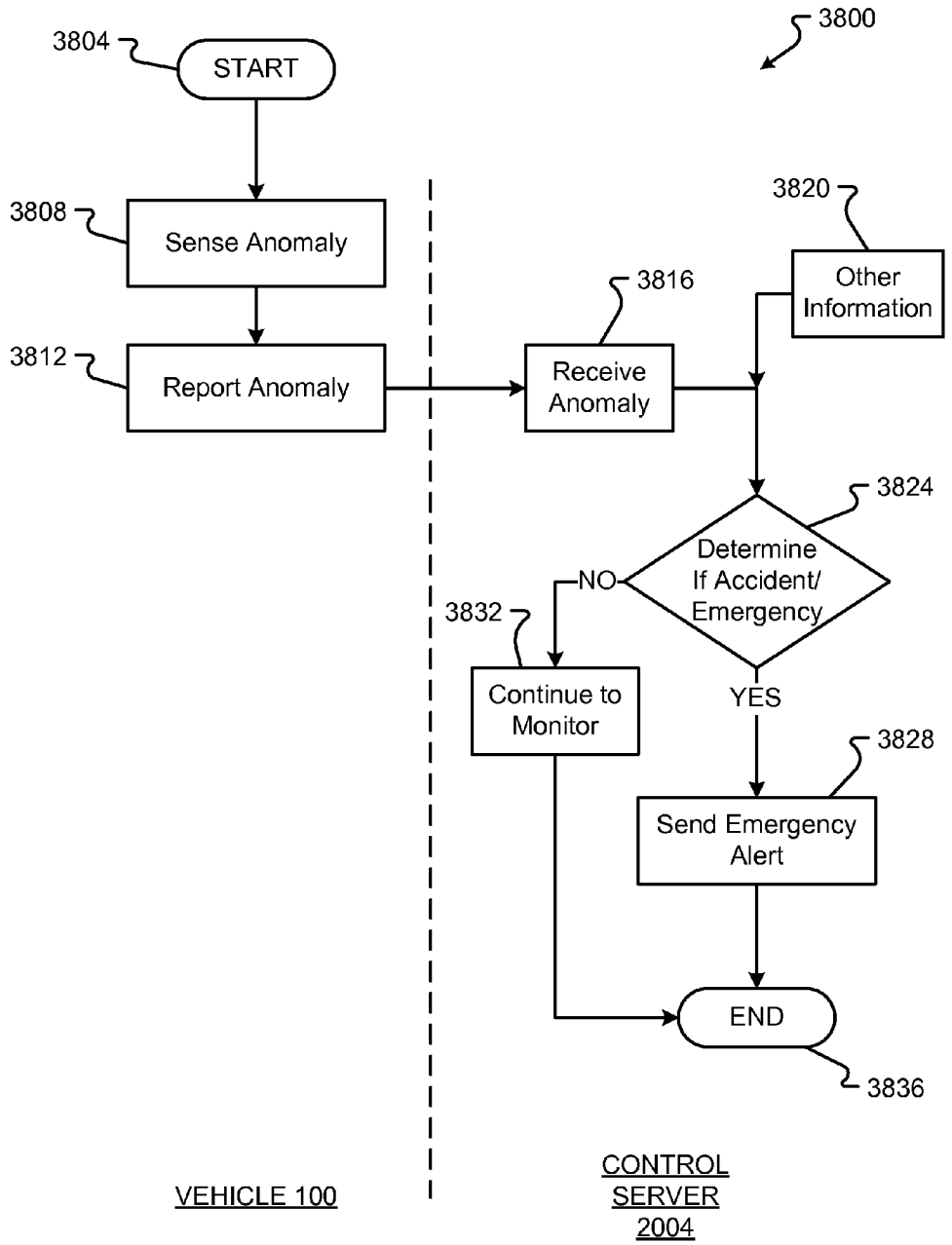

Fig. 38

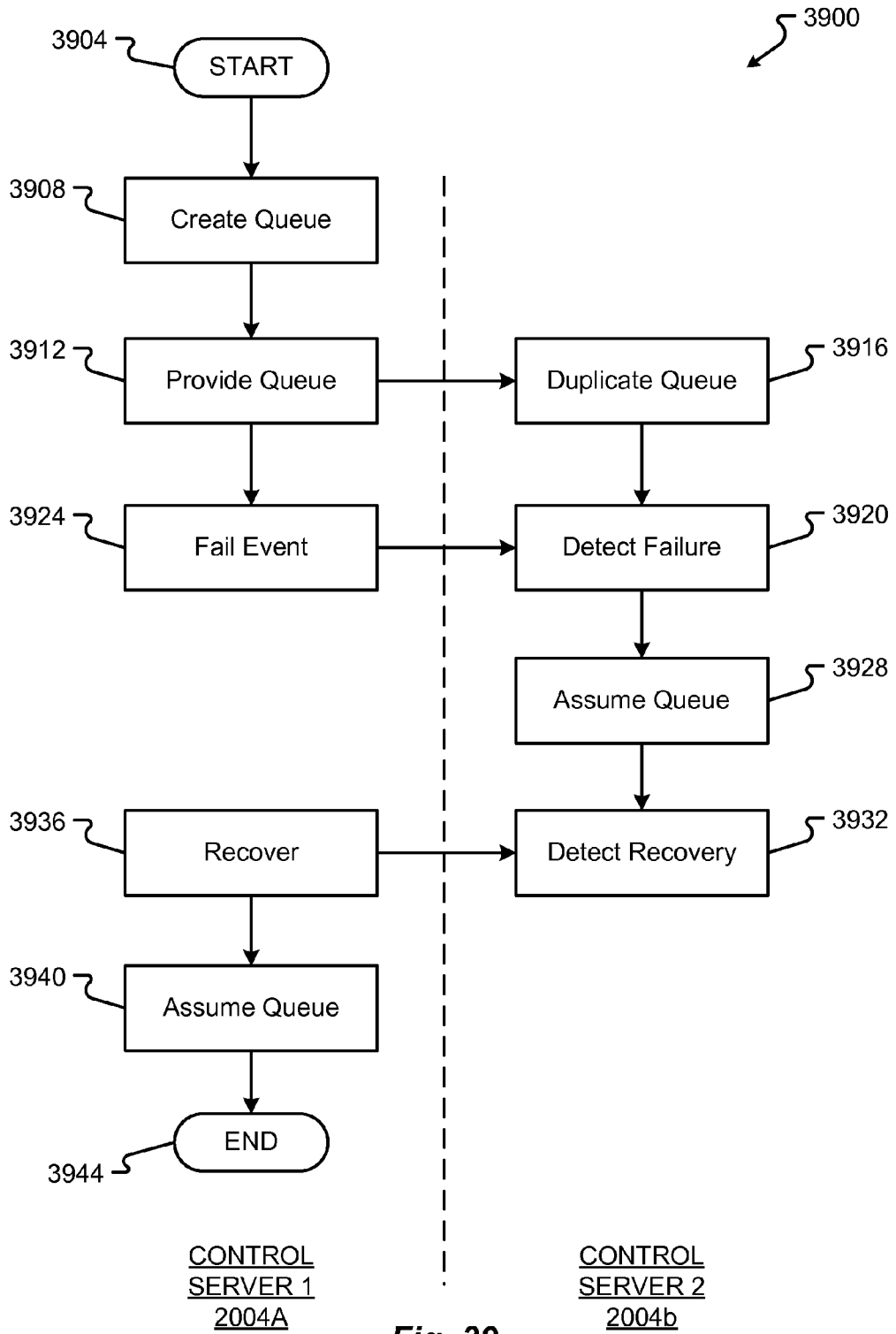

Fig. 39

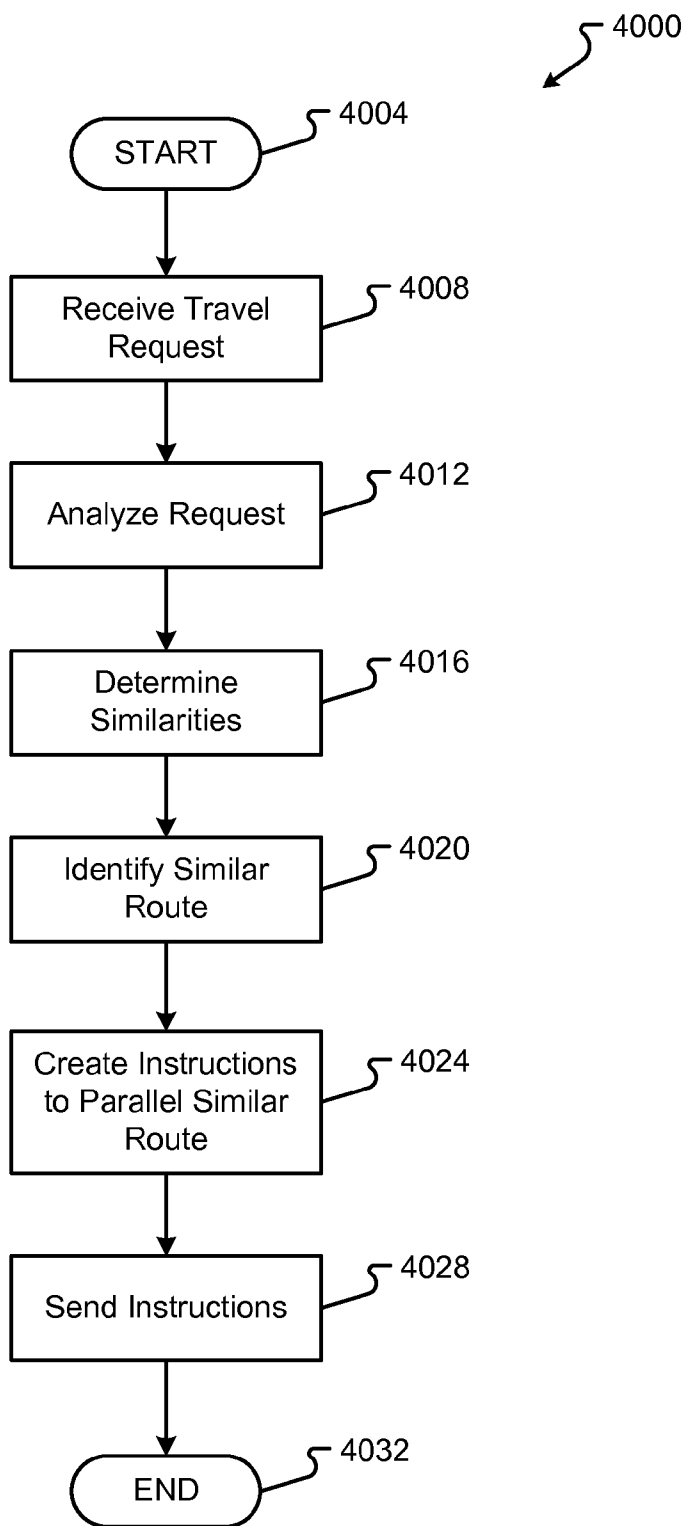

Fig. 40

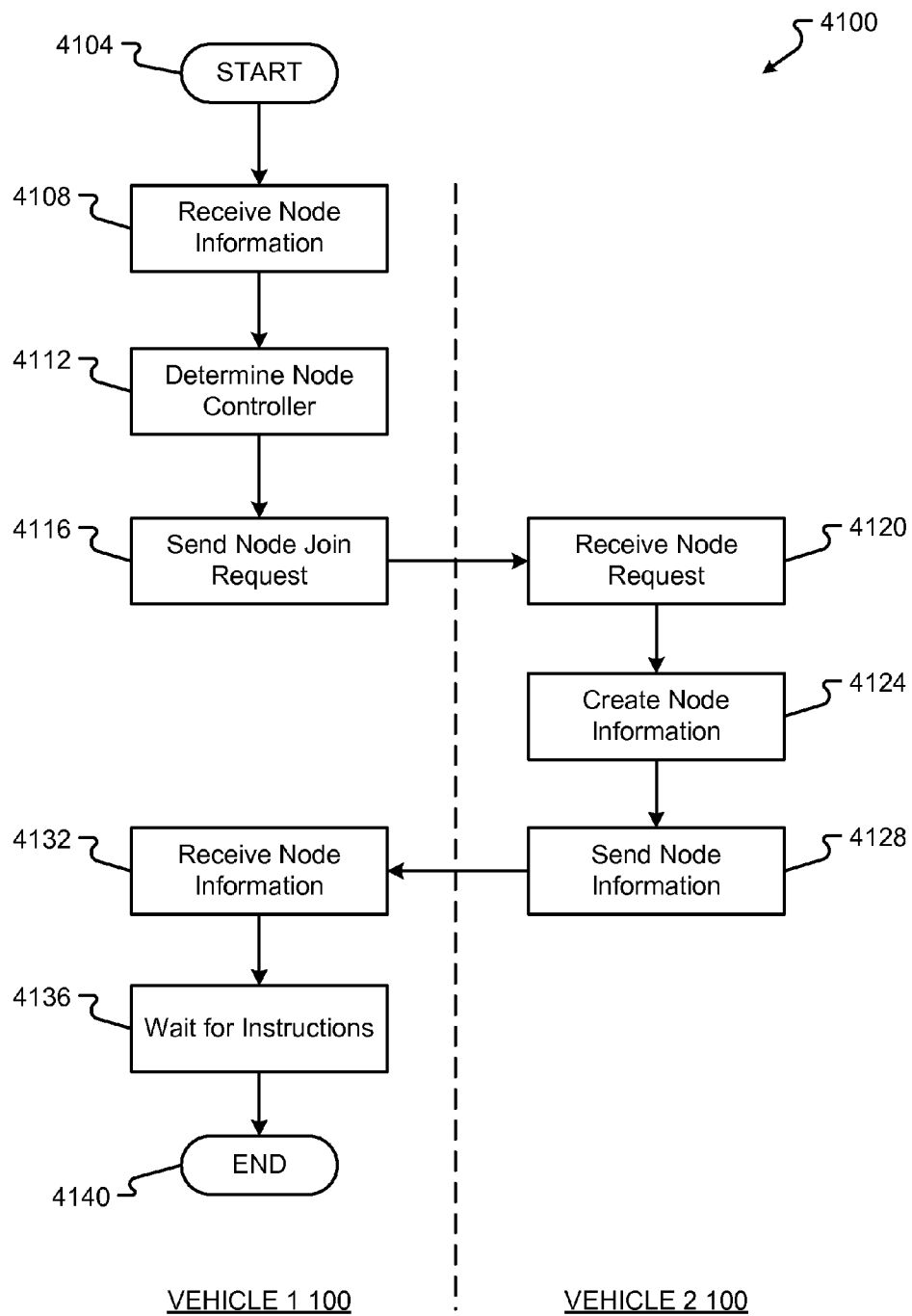

Fig. 41

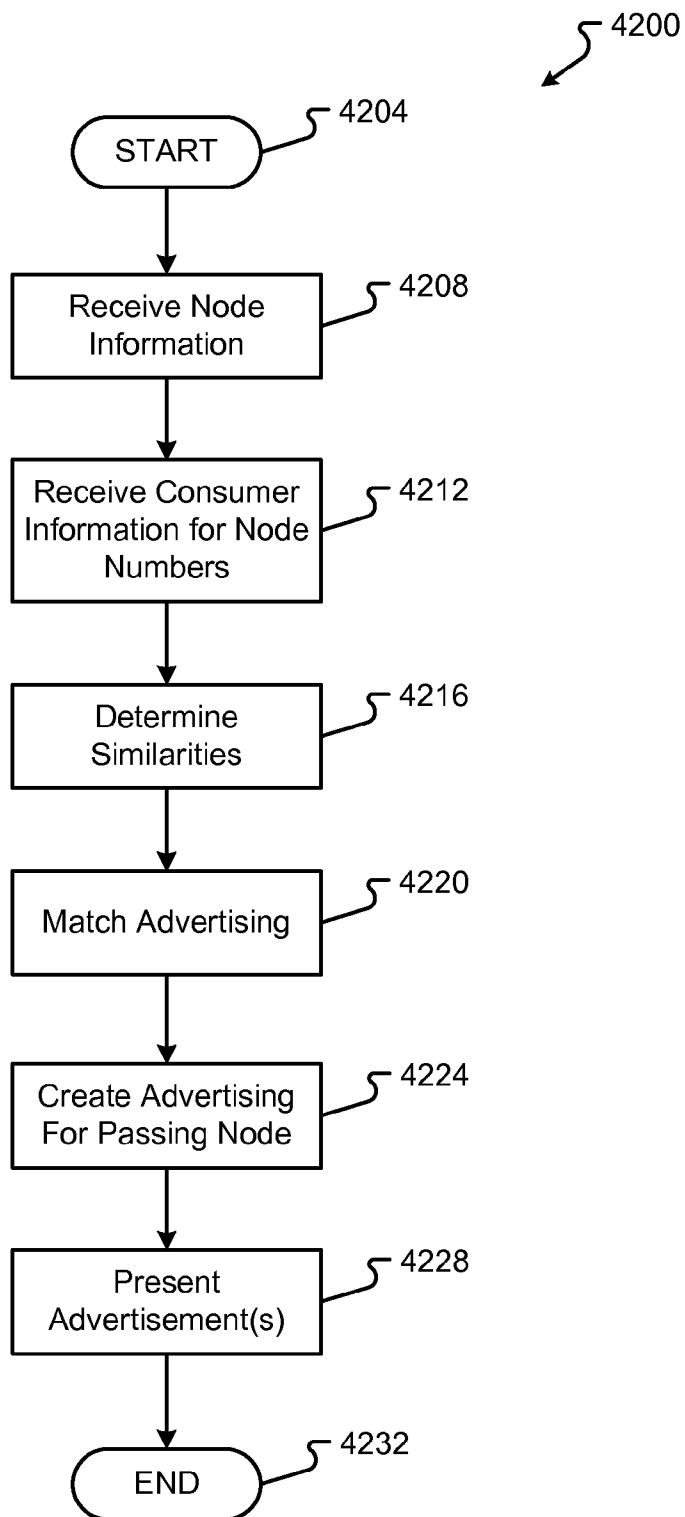

Fig. 42

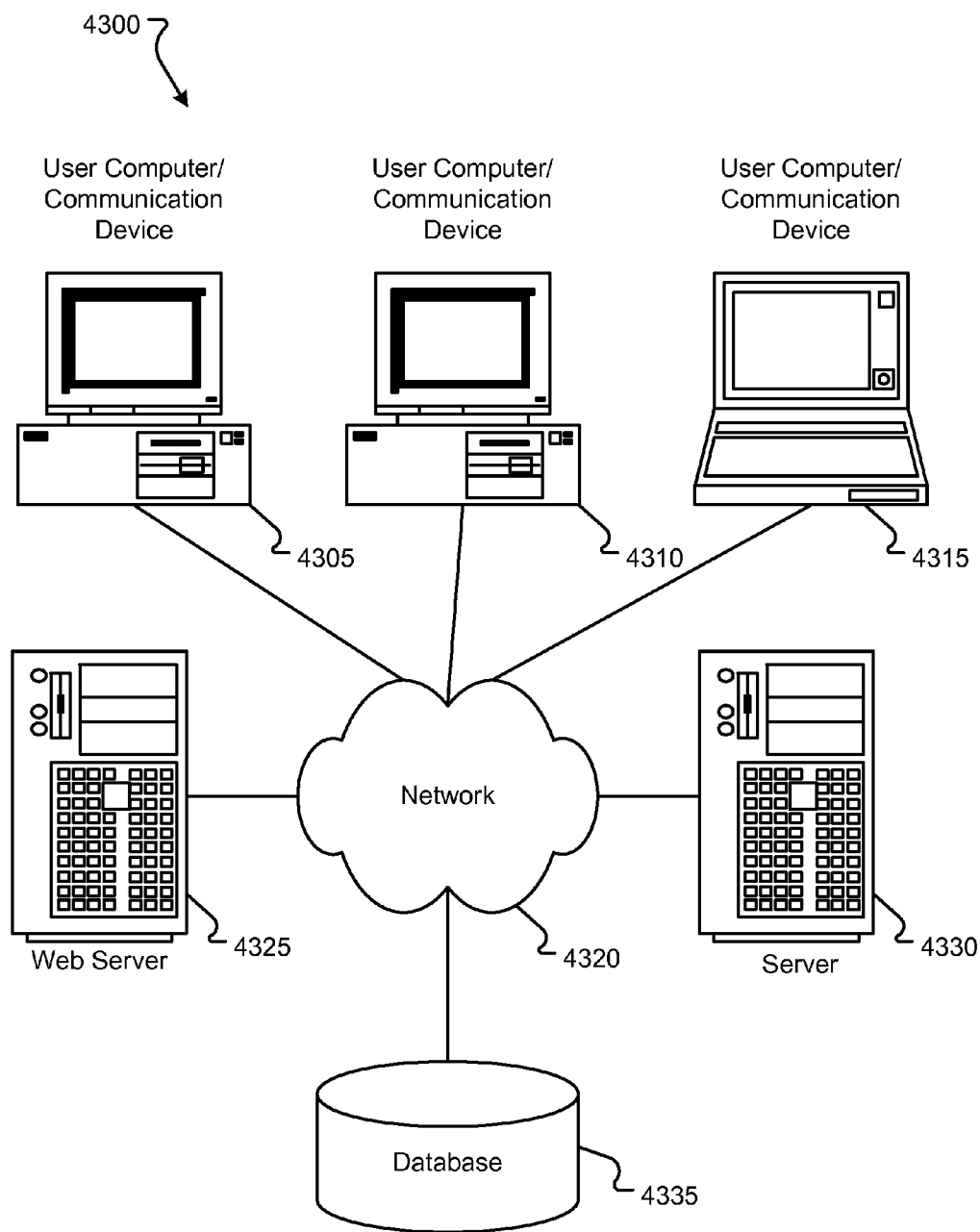

Fig. 43

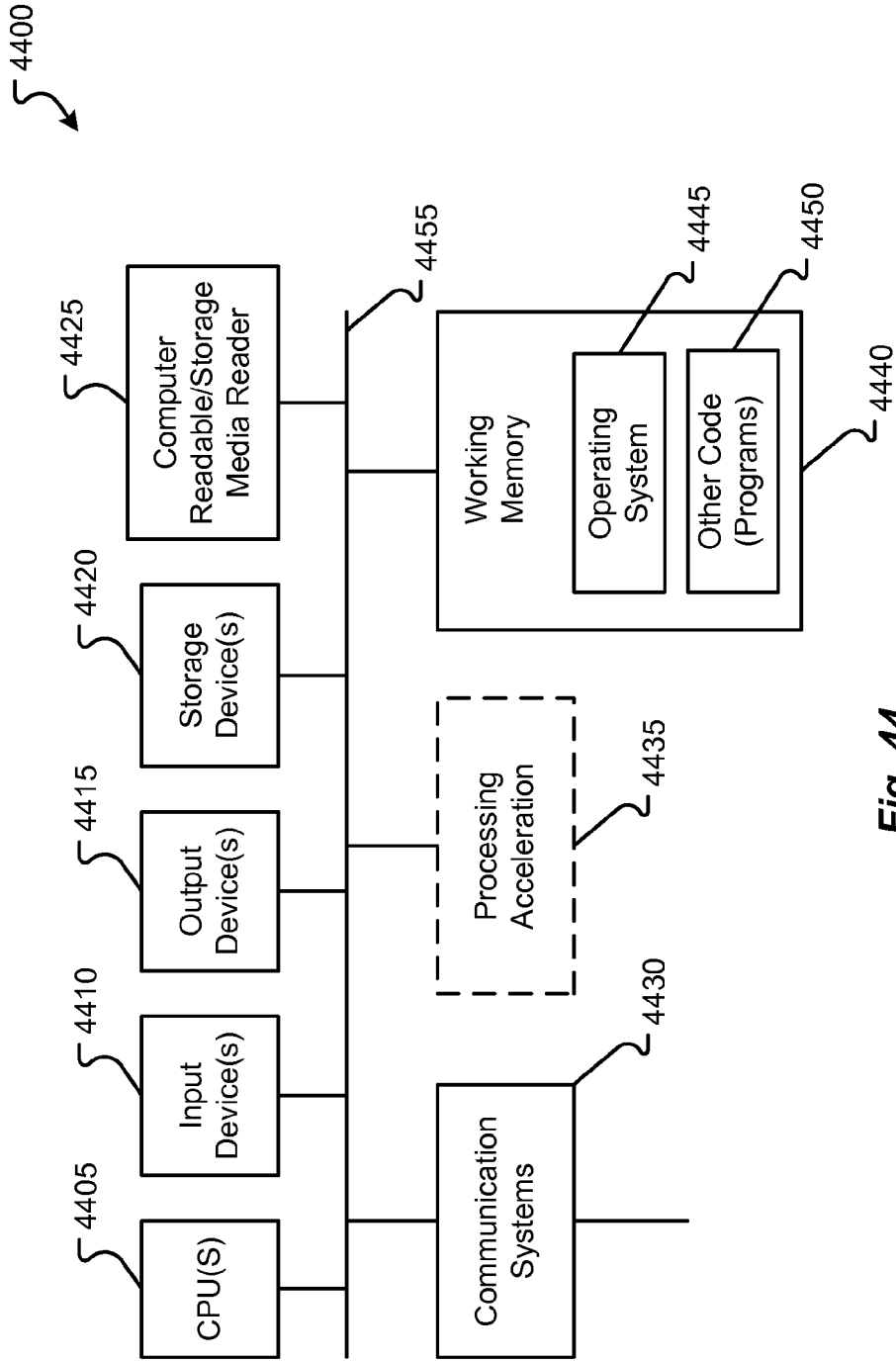

Fig. 44

**RELAY AND EXCHANGE PROTOCOL IN AN
AUTOMATED ZONE-BASED VEHICULAR
TRAFFIC CONTROL ENVIRONMENT**

CROSS REFERENCE TO RELATED
APPLICATIONS

[0001] The present application is a continuation of and claims priority to U.S. patent application Ser. No. 14/253,836, filed on Apr. 15, 2014, of the same title, which claims the benefits of and priority, under 35 U.S.C. §119(e), to U.S. Provisional Application Ser. Nos. 61/811,981, filed on Apr. 15, 2013, entitled “Functional Specification for a Next Generation Automobile”; 61/865,954, filed on Aug. 14, 2013, entitled “Gesture Control of Vehicle Features”; 61/870,698, filed on Aug. 27, 2013, entitled “Gesture Control and User Profiles Associated with Vehicle Features”; 61/891,217, filed on Oct. 15, 2013, entitled “Gesture Control and User Profiles Associated with Vehicle Features”; 61/904,205, filed on Nov. 14, 2013, entitled “Gesture Control and User Profiles Associated with Vehicle Features”; 61/924,572, filed on Jan. 7, 2014, entitled “Gesture Control and User Profiles Associated with Vehicle Features”; and 61/926,749, filed on Jan. 13, 2014, entitled “Method and System for Providing Infotainment in a Vehicle.” The entire disclosures of the applications listed above are hereby incorporated by reference, in their entirety, for all that they teach and for all purposes.

[0002] This application is also related to U.S. patent application Ser. No. 13/420,236, filed on Mar. 14, 2012, entitled, “Configurable Vehicle Console”; Ser. No. 13/420,240, filed on Mar. 14, 2012, entitled “Removable, Configurable Vehicle Console”; Ser. No. 13/462,593, filed on May 2, 2012, entitled “Configurable Dash Display”; Ser. No. 13/462,596, filed on May 2, 2012, entitled “Configurable Heads-Up Dash Display”; Ser. No. 13/679,459, filed on Nov. 16, 2012, entitled “Vehicle Comprising Multi-Operating System”; Ser. No. 13/679,234, filed on Nov. 16, 2012, entitled “Gesture Recognition for On-Board Display”; Ser. No. 13/679,412, filed on Nov. 16, 2012, entitled “Vehicle Application Store for Console”; Ser. No. 13/679,857, filed on Nov. 16, 2012, entitled “Sharing Applications/Media Between Car and Phone (Hydroid)”; Ser. No. 13/679,878, filed on Nov. 16, 2012, entitled “In-Cloud Connection for Car Multimedia”; Ser. No. 13/679,875, filed on Nov. 16, 2012, entitled “Music Streaming”; Ser. No. 13/679,676, filed on Nov. 16, 2012, entitled “Control of Device Features Based on Vehicle State”; Ser. No. 13/678,673, filed on Nov. 16, 2012, entitled “Insurance Tracking”; Ser. No. 13/678,691, filed on Nov. 16, 2012, entitled “Law Breaking/Behavior Sensor”; Ser. No. 13/678,699, filed on Nov. 16, 2012, entitled “Etiquette Suggestion”; Ser. No. 13/678,710, filed on Nov. 16, 2012, entitled “Parking Space Finder Based on Parking Meter Data”; Ser. No. 13/678,722, filed on Nov. 16, 2012, entitled “Parking Meter Expired Alert”; Ser. No. 13/678,726, filed on Nov. 16, 2012, entitled “Object Sensing (Pedestrian Avoidance/Accident Avoidance)”; Ser. No. 13/678,735, filed on Nov. 16, 2012, entitled “Proximity Warning Relative to Other Cars”; Ser. No. 13/678,745, filed on Nov. 16, 2012, entitled “Street Side Sensors”; Ser. No. 13/678,753, filed on Nov. 16, 2012, entitled “Car Location”; Ser. No. 13/679,441, filed on Nov. 16, 2012, entitled “Universal Bus in the Car”; Ser. No. 13/679,864, filed on Nov. 16, 2012, entitled “Mobile Hot Spot/Router/Application Share Site or Network”; Ser. No. 13/679,815, filed on Nov. 16, 2012, entitled “Universal Console Chassis for the Car”; Ser. No. 13/679,476, filed on Nov. 16, 2012, entitled “Vehicle

Middleware”; Ser. No. 13/679,306, filed on Nov. 16, 2012, entitled “Method and System for Vehicle Data Collection Regarding Traffic”; Ser. No. 13/679,369, filed on Nov. 16, 2012, entitled “Method and System for Vehicle Data Collection”; Ser. No. 13/679,680, filed on Nov. 16, 2012, entitled “Communications Based on Vehicle Diagnostics and Indications”; Ser. No. 13/679,443, filed on Nov. 16, 2012, entitled “Method and System for Maintaining and Reporting Vehicle Occupant Information”; Ser. No. 13/678,762, filed on Nov. 16, 2012, entitled “Behavioral Tracking and Vehicle Applications”; Ser. No. 13/679,292, filed on Nov. 16, 2012, entitled “Branding of Electrically Propelled Vehicles Via the Generation of Specific Operating Output”; Ser. No. 13/679,400, filed on Nov. 16, 2012, entitled “Vehicle Climate Control”; Ser. No. 13/840,240, filed on Mar. 15, 2013, entitled “Controller Area Network Bus”; Ser. No. 13/678,773, filed on Nov. 16, 2012, entitled “Location Information Exchange Between Vehicle and Device”; Ser. No. 13/679,887, filed on Nov. 16, 2012, entitled “In Car Communication Between Devices”; Ser. No. 13/679,842, filed on Nov. 16, 2012, entitled “Configurable Hardware Unit for Car Systems”; Ser. No. 13/679,204, filed on Nov. 16, 2012, entitled “Feature Recognition for Configuring a Vehicle Console and Associated Devices”; Ser. No. 13/679,350, filed on Nov. 16, 2012, entitled “Configurable Vehicle Console”; Ser. No. 13/679,358, filed on Nov. 16, 2012, entitled “Configurable Dash Display”; Ser. No. 13/679,363, filed on Nov. 16, 2012, entitled “Configurable Heads-Up Dash Display”; and Ser. No. 13/679,368, filed on Nov. 16, 2012, entitled “Removable, Configurable Vehicle Console”. The entire disclosures of the applications listed above are hereby incorporated by reference, in their entirety, for all that they teach and for all purposes.

BACKGROUND

[0003] Whether using private, commercial, or public transport, the movement of people and/or cargo has become a major industry. In today’s interconnected world, daily travel is essential to engaging in commerce. Commuting to and from work can account for a significant portion of a traveler’s day. As a result, vehicle manufacturers have begun to focus on making this commute, and other journeys, more enjoyable.

[0004] Currently, vehicle manufacturers attempt to entice travelers to use a specific conveyance based on any number of features. Most of these features focus on vehicle safety or efficiency. From the addition of safety-restraints, air-bags, and warning systems to more efficient engines, motors, and designs, the vehicle industry has worked to appease the supposed needs of the traveler. Recently, however, vehicle manufacturers have shifted their focus to user and passenger comfort as a primary concern. Making an individual more comfortable while traveling instills confidence and pleasure in using a given vehicle, increasing an individual’s preference for a given manufacturer and/or vehicle type.

[0005] One way to instill comfort in a vehicle is to create an environment within the vehicle similar to that of an individual’s home. Integrating features in a vehicle that are associated with comfort found in an individual’s home can ease a traveler’s transition from home to vehicle. Several manufacturers have added comfort features in vehicles, such as, the following: leather seats, adaptive and/or personal climate control systems, music and media players, ergonomic controls, and, in some cases, Internet connectivity. However, because these

manufacturers have added features to a conveyance, they have built comfort around a vehicle and failed to build a vehicle around comfort.

SUMMARY

[0006] There is a need for a vehicle ecosystem, which can integrate both physical and mental comforts, while seamlessly communicating with current electronic devices to result in a totally intuitive and immersive user experience. These and other needs are addressed by the various aspects, embodiments, and/or configurations of the present disclosure. Also, while the disclosure is presented in terms of exemplary and optional embodiments, it should be appreciated that individual aspects of the disclosure can be separately claimed.

[0007] Embodiments include a method for controlling a vehicle, comprising: a control server, including a processor and associated with a traffic control system, receiving a registration of a vehicle; the control server receiving travel information from the vehicle; the control server determining a control arrangement for the vehicle; and the control server sending a control message to control the vehicle in the traffic control system.

[0008] Aspects of the above method include wherein the vehicle automatically, without driver input, follows instructions in the control message.

[0009] Aspects of the above method include wherein the travel information includes a current location and a destination.

[0010] Aspects of the above method include wherein the control information includes a speed and a position within traffic to which the vehicle must adhere.

[0011] Aspects of the above method include wherein the vehicle generates a route based on the control arrangement.

[0012] Aspects of the above method include wherein the vehicle follows the route automatically without driver input.

[0013] Aspects of the above method include wherein the control server sends a second control message to change a behavior of the vehicle.

[0014] Aspects of the above method include wherein the second message is instructs the vehicle to exit from a roadway.

[0015] Aspects of the above method include wherein the control message includes a lane designation.

[0016] Aspects of the above method include wherein a second vehicle receives a second the control message, wherein the second control message is different from the control message sent to the vehicle.

[0017] Embodiments include a control server associated with a traffic control system comprising: a processor operable to execute one or more modules, the modules comprising: a registration module operable to: receive a registration of a vehicle; a traffic control module operable to: receive travel information from the vehicle; determine a control arrangement for the vehicle; and send a control message to control the vehicle in the traffic control system.

[0018] Aspects of the above control server include wherein the vehicle generates a route based on the control arrangement, and wherein the vehicle follows the route automatically without driver input.

[0019] Aspects of the above control server include wherein the control server sends a second control message to change a behavior of the vehicle, and wherein the second message is instructs the vehicle to exit from a roadway.

[0020] Aspects of the above control server include wherein the control information includes one or more of a lane, a speed, and a position within traffic to which the vehicle must adhere.

[0021] Aspects of the above control server include wherein the travel information includes a current location and a destination.

[0022] Embodiments include a non-transitory computer readable medium stored on a storage medium and having instructions that when executed by a processor cause the processor to perform a method, the instructions comprising: instructions to receive a registration of a vehicle; instructions to receive travel information from the vehicle; instructions to determine a control arrangement for the vehicle; and instructions to send a control message to control the vehicle in the traffic control system.

[0023] Aspects of the above computer readable medium include wherein the vehicle generates a route based on the control arrangement, and wherein the vehicle follows the route automatically without driver input.

[0024] Aspects of the above computer readable medium include wherein the control server sends a second control message to change a behavior of the vehicle, and wherein the second message is instructs the vehicle to exit from a roadway.

[0025] Aspects of the above computer readable medium include wherein the control information includes one or more of a lane, a speed, and a position within traffic to which the vehicle must adhere.

[0026] Aspects of the above computer readable medium include wherein the travel information includes a current location and a destination.

[0027] Embodiments include a method for controlling a vehicle, comprising: a control server, including a processor and associated with a traffic control system, receiving a registration request sent from a vehicle; the control server assigning an identifier to the vehicle; the control server registering the vehicle with the traffic control system; and the control server providing directions to the vehicle to which to form a route.

[0028] Aspects of the above method include wherein the identifier and the directions are sent to the vehicle.

[0029] Aspects of the above method include wherein the registration request includes travel information associated with the vehicle.

[0030] Aspects of the above method include wherein the travel information includes a present location and a destination.

[0031] Aspects of the above method include wherein the identifier is dynamically assigned when the vehicle enters the traffic control system.

[0032] Aspects of the above method include wherein the vehicle generates a route based on the directions.

[0033] Aspects of the above method include wherein the vehicle follows the route automatically without driver input.

[0034] Aspects of the above method include wherein the directions include a speed, a lane, and a position within traffic to which the vehicle must adhere.

[0035] Aspects of the above method include wherein the control server maintains the vehicle as an item in a queue until the vehicle leaves the traffic control system.

[0036] Aspects of the above method include wherein each item in the queue represents a different vehicle in the traffic control system.

[0037] Embodiments include a control server comprising: a processor operable to execute one or more modules, the modules comprising: a registration module operable to: receive a registration request sent from a vehicle; assign an identifier to the vehicle; register the vehicle with the traffic control system; and a traffic control module operable to: provide directions to the vehicle to which to form a route.

[0038] Aspects of the above control server include wherein the identifier is dynamically assigned when the vehicle enters the traffic control system, wherein the identifier and the directions are sent to the vehicle, and wherein the directions include a speed, a lane, and a position within traffic to which the vehicle must adhere.

[0039] Aspects of the above control server include wherein the registration request includes travel information associated with the vehicle, wherein the travel information includes a present location and a destination.

[0040] Aspects of the above control server include and wherein the vehicle follows the route automatically without driver input.

[0041] Aspects of the above control server include wherein the control server maintains the vehicle as an item in a queue until the vehicle leaves the traffic control system, wherein each item in the queue represents a different vehicle in the traffic control system.

[0042] Embodiments include a non-transitory computer readable medium stored on a storage medium and having instructions that when executed by a processor cause the processor to perform a method, the instructions comprising: instructions to receive a registration request sent from a vehicle; instructions to assign an identifier to the vehicle; instructions to register the vehicle with the traffic control system; and instructions to provide directions to the vehicle to which to form a route.

[0043] Aspects of the above computer readable medium include wherein the identifier is dynamically assigned when the vehicle enters the traffic control system, wherein the identifier and the directions are sent to the vehicle, and wherein the directions include a speed, a lane, and a position within traffic to which the vehicle must adhere.

[0044] Aspects of the above computer readable medium include wherein the registration request includes travel information associated with the vehicle, wherein the travel information includes a present location and a destination.

[0045] Aspects of the above computer readable medium include wherein the vehicle generates a route based on the directions, and wherein the vehicle follows the route automatically without driver input.

[0046] Aspects of the above computer readable medium include wherein the control server maintains the vehicle as an item in a queue until the vehicle leaves the traffic control system, wherein each item in the queue represents a different vehicle in the traffic control system.

[0047] Embodiments include a method for providing navigation information for a control server, comprising: a first control server, including a processor, determining that a vehicle in a traffic control system is leaving a first zone; the first control server determining a second zone to which a vehicle is entering; and the first control server passing the vehicle to the second zone.

[0048] Aspects of the above method include wherein a second control server receives the vehicle into the second zone.

[0049] Aspects of the above method include wherein the first control server maintains the vehicle as an item in a first.

[0050] Aspects of the above method include wherein, when the first control server passes the vehicle to the second zone, the second control server accepts the vehicle as an item in a second queue administered by the second control server.

[0051] Aspects of the above method further comprises: the second control server establishing communication with the vehicle; and the second control determining if the vehicle has confirmed that communication has been established.

[0052] Aspects of the above method further comprises, if the vehicle has not confirmed that communication has been established, the second control server re-establishing communication with the vehicle.

[0053] Aspects of the above method include wherein each zone is defined by an extents.

[0054] Aspects of the above method include wherein the extents are associated with a range of an antennae associated with the zone and in communication with the vehicle.

[0055] Aspects of the above method include wherein the extents are defined by two or more physical locations along a roadway.

[0056] Aspects of the above method include wherein the first control server passes the vehicle to the second zone when a boundary condition is met that defines when to pass control of the vehicle.

[0057] Embodiments include a control server comprising: a processor operable to execute one or more modules, the modules comprising: a traffic control module operable to determine that a vehicle in a traffic control system is leaving a first zone; a zonal communication module operable to: determine a second zone to which a vehicle is entering; and pass the vehicle to the second zone.

[0058] Aspects of the above control server include wherein the first control server maintains the vehicle as an item in a first, and wherein, when the first control server passes the vehicle to the second zone, the second control server accepts the vehicle as an item in a second queue administered by the second control server.

[0059] Aspects of the above control server include wherein a second traffic control module, associated with the second control server, is further operable to: establish communication with the vehicle; and determine if the vehicle has confirmed that communication has been established.

[0060] Aspects of the above control server include wherein the second traffic control module is further operable to, if the vehicle has not confirmed that communication has been established, re-establish communication with the vehicle.

[0061] Aspects of the above control server include wherein each zone is defined by an extents, wherein the extents are defined by one of a range of an antennae associated with the zone and in communication with the vehicle or by two or more physical locations along a roadway.

[0062] Embodiments include a non-transitory computer readable medium stored on a storage medium and having instructions that when executed by a processor cause the processor to perform a method, the instructions comprising: instructions to determine that a vehicle in a traffic control system is leaving a first zone; instructions to determine a second zone to which a vehicle is entering; and instructions to pass the vehicle to the second zone.

[0063] Aspects of the above computer readable medium include wherein the first control server maintains the vehicle as an item in a first, and wherein, when the first control server passes the vehicle to the second zone, the second control

server accepts the vehicle as an item in a second queue administered by the second control server.

[0064] Aspects of the above computer readable medium further comprises: instructions to establish communication with the vehicle; and instructions to determine if the vehicle has confirmed that communication has been established.

[0065] Aspects of the above computer readable medium further comprises, if the vehicle has not confirmed that communication has been established, instructions to re-establish communication with the vehicle.

[0066] Aspects of the above computer readable medium include wherein each zone is defined by an extents, wherein the extents are defined by one of a range of an antennae associated with the zone and in communication with the vehicle or by two or more physical locations along a roadway.

[0067] Embodiments include a method for providing navigation information for a control server, comprising: a control server, including a processor, receiving two or more travel requests, wherein each travel request is from a different vehicle; the control server analyzing the two or more travel requests; the control server determining a similarity between at least two or the travel requests; the control server determining a similar route for the vehicles associated with the at least two or similar travel requests; and the control server creating instructions to consolidate the vehicles, with the similar routes, into spatial proximity while traveling in the traffic control system.

[0068] Aspects of the above method further comprises the control server sending the instructions to the vehicles with the similar routes.

[0069] Aspects of the above method include wherein the similarity is common destination.

[0070] Aspects of the above method further comprises the control server comparing one portion of a first travel request with a second portion of a second travel request.

[0071] Aspects of the above method include wherein the first travel request is associated with a first vehicle and the second travel request is associated with a second vehicle.

[0072] Aspects of the above method include wherein a similarity exists if the first portion and the second portion compare.

[0073] Aspects of the above method include wherein the instructions cause the vehicles to travel in a common position while on the roadway.

[0074] Aspects of the above method include wherein the common position is in a same lane.

[0075] Aspects of the above method include wherein the vehicles are next to each other.

[0076] Aspects of the above method include wherein the consolidation is accomplished based on the distance the vehicles need to travel.

[0077] Embodiments include a control server comprising: a processor operable to execute one or more modules, the modules comprising: a traffic control module operable to: receive two or more travel requests, wherein each travel request is from a different vehicle; analyze the two or more travel requests; determine a similarity between at least two or the travel requests; determine a similar route for the vehicles associated with the at least two or similar travel requests; and create instructions to consolidate the vehicles, with the similar routes, into spatial proximity while traveling in the traffic control system.

[0078] Aspects of the above control server include wherein the traffic control module is further operable to compare one portion of a first travel request with a second portion of a second travel request.

[0079] Aspects of the above control server include wherein the first travel request is associated with a first vehicle and the second travel request is associated with a second vehicle, wherein a similarity exists if the first portion and the second portion compare, and wherein the similarity is common destination.

[0080] Aspects of the above control server include wherein the instructions cause the vehicles to travel in a common position while on the roadway, and wherein the common position is in a same lane, and next to each other.

[0081] Aspects of the above control server include wherein the consolidation is accomplished based on the distance the vehicles need to travel.

[0082] Embodiments include a non-transitory computer readable medium stored on a storage medium and having instructions that when executed by a processor cause the processor to perform a method, the instructions comprising: instructions to receive two or more travel requests, wherein each travel request is from a different vehicle; instructions to analyze the two or more travel requests; instructions to determine a similarity between at least two or the travel requests; instructions to determine a similar route for the vehicles associated with the at least two or similar travel requests; and instructions to create instructions to consolidate the vehicles, with the similar routes, into spatial proximity while traveling in the traffic control system.

[0083] Aspects of the above computer readable medium further comprises instructions to compare one portion of a first travel request with a second portion of a second travel request.

[0084] Aspects of the above computer readable medium include wherein the first travel request is associated with a first vehicle and the second travel request is associated with a second vehicle, wherein a similarity exists if the first portion and the second portion compare, and wherein the similarity is common destination.

[0085] Aspects of the above computer readable medium include wherein the instructions cause the vehicles to travel in a common position while on the roadway, and wherein the common position is in a same lane, and next to each other.

[0086] Aspects of the above computer readable medium include wherein the consolidation is accomplished based on the distance the vehicles need to travel.

[0087] Embodiments include methods, systems, devices, computer readable medium, computing systems, and/or means for providing navigation information for a control server, comprising: a control server, including a processor and associated with a traffic control system, receiving route information from a vehicle; the control server determining the travel parameters for the route information; the control server forming a passive message for the vehicle to be controlled in the traffic control system; and the control server sending the passive message to the vehicle.

[0088] Aspects of the above further comprises the control server determining if passive control is appropriate.

[0089] Aspects of the above include wherein the travel parameters include a capability of the vehicle.

[0090] Aspects of the above include wherein the capability of the vehicle determines if passive control is appropriate.

- [0091] Aspects of the above include wherein the passive message includes less information than an active message.
- [0092] Aspects of the above include wherein the passive message only includes a position and a speed.
- [0093] Aspects of the above include wherein the vehicle creates other travel directions based on the position and speed received in the passive message.
- [0094] Aspects of the above include wherein the vehicle establishes control when receiving the passive message.
- [0095] Aspects of the above include wherein the passive message is a default message sent to a vehicle.
- [0096] Aspects of the above include wherein the vehicle forms a route from the passive message.
- [0097] Embodiments include methods, systems, devices, computer readable medium, computing systems, and/or means for providing navigation information for a control server, comprising: a vehicle control system, including a processor and associated with a traffic control system, receiving route information from a vehicle; the vehicle control system determining the travel parameters for the route information; the vehicle control system forming an active message for the vehicle to be controlled in the traffic control system; and the vehicle control system sending the active message to the vehicle.
- [0098] Aspects of the above further comprises the control server determining if passive control is appropriate.
- [0099] Aspects of the above include wherein the travel parameters include a capability of the vehicle.
- [0100] Aspects of the above include wherein the capability of the vehicle determines if passive control is appropriate.
- [0101] Aspects of the above include wherein the active message includes more information than a passive message.
- [0102] Aspects of the above include wherein the active message includes a position, a speed, and at least one other parameter.
- [0103] Aspects of the above include wherein the vehicle creates other travel directions based on the position, speed, and the at least one other parameter received in the active message.
- [0104] Aspects of the above include wherein the vehicle does not establish control when receiving the active message.
- [0105] Aspects of the above include wherein the active message is a default message sent to a vehicle.
- [0106] Aspects of the above include wherein the vehicle forms a route from the active message.
- [0107] Embodiments include methods, systems, devices, computer readable medium, computing systems, and/or means for providing navigation information for a control server, comprising: a vehicle control system, including a processor and registered with a traffic control system, determining that a message is required; the vehicle control system determining if the message is meant for the traffic control system; if the message is meant for the traffic control system, the vehicle control system forming a message having an address for a control server in the traffic control system; and the vehicle control system sending the message to the traffic control system.
- [0108] Aspects of the above further comprises, if the message is not meant for the traffic control system, the vehicle control system determining if the message is meant for another vehicle.
- [0109] Aspects of the above further comprises: if the message is meant for another vehicle, the vehicle control system forming the message having an address for a second vehicle in the traffic control system; and the vehicle control system sending the message to the second vehicle.
- [0110] Aspects of the above further comprises, if the message is meant for another vehicle, the vehicle control system requesting further definition of the message.
- [0111] Aspects of the above include wherein the address for a second vehicle is a vehicle identifier.
- [0112] Aspects of the above further comprises determining if a confirmation is received.
- [0113] Aspects of the above further comprises, if a confirmation is not received, resending the message.
- [0114] Aspects of the above further comprises the vehicle control system receiving a message.
- [0115] Aspects of the above further comprises the vehicle control system determining if the message is from another vehicle.
- [0116] Aspects of the above further comprises: if the message is from another vehicle, the vehicle control system sending a confirmation to the other vehicle; and if the message is not from another vehicle, the vehicle control system sending a confirmation to the control server.
- [0117] Embodiments include methods, systems, devices, computer readable medium, computing systems, and/or means for providing navigation information for a control server, comprising: a control server, including a processor and associated with a traffic control system, receiving information about an anomaly in the traffic control system; the control server determining if the anomaly is an accident or emergency on a roadway; and if the anomaly is an accident or emergency on a roadway, the control server sending an emergency alert to a vehicle in the traffic control system.
- [0118] Aspects of the above include wherein the emergency alert includes directions to avoid the accident or emergency.
- [0119] Aspects of the above include wherein the emergency alert is a burst message.
- [0120] Aspects of the above include wherein the vehicle determines if the emergency alert requires a travel change.
- [0121] Aspects of the above include wherein if the emergency alert requires a travel change, the vehicle adjust a route of travel.
- [0122] Aspects of the above include wherein the accident or emergency blocks a portion of the roadway.
- [0123] Aspects of the above include wherein a second vehicle sends the anomaly to the control server.
- [0124] Aspects of the above include wherein the second vehicle detects the anomaly based on a deviation from a planned route of travel.
- [0125] Aspects of the above include wherein the deviation is a sudden change in direction.
- [0126] Aspects of the above include wherein the deviation is a sudden deceleration.
- [0127] Embodiments include methods, systems, devices, computer readable medium, computing systems, and/or means for providing navigation information for a first or second control server, comprising: the first control server, including a processor and associated with a traffic control system, creating a queue to maintain as an item vehicle information for a vehicle being controlled by the traffic control system; the control server providing the queue to a second control server; the control suffering a fail event, wherein, in response to the fail event, the queue is assumed by the second control server.

[0128] Aspects of the above include wherein the second control server duplicates the queue.

[0129] Aspects of the above include wherein the second control server administers the duplicate queue as an inactive queue in a queues database.

[0130] Aspects of the above include wherein, upon the fail event, the duplicate queue becomes an active queue for the second control server.

[0131] Aspects of the above include wherein, after the duplicate queue becomes an active queue, the second control server establishes communication with the vehicle.

[0132] Aspects of the above include wherein the second control server detects the fail event.

[0133] Aspects of the above include wherein the second control server detects a recovery of the first control server.

[0134] Aspects of the above include wherein, upon a recovery event, the first control server re-assumes the queue.

[0135] Aspects of the above include wherein, after the queue is re-assumed, the first control server re-establishes communication with the vehicle.

[0136] Aspects of the above include wherein the fail event is one of a power failure or a hardware failure.

[0137] Embodiments include methods, systems, devices, computer readable medium, computing systems, and/or means for providing navigation information for a control server, comprising: a control server, including a processor and associated with a traffic control system, establishing a coverage area for the traffic control system; the control server determining a first portion of the coverage area that is associated with a first zone; the control server determining a second portion of the coverage area that is associated with a second zone; and the control server determining a boundary between the first and second zones.

[0138] Aspects of the above include wherein the first and second zones overlap.

[0139] Aspects of the above include wherein the first zone is associated with a first range of a first antennae and the second zone is associated with a second range of a second antennae.

[0140] Aspects of the above include wherein the boundary is delineated by a physical marker or street.

[0141] Aspects of the above further comprises the control server establishing boundary conditions.

[0142] Aspects of the above include wherein the boundary conditions define when a vehicle passes from the first zone to the second zone.

[0143] Aspects of the above include wherein when a vehicle passes from the first zone to the second zone, a hand-off from the first zone to the second zone is performed.

[0144] Aspects of the above include wherein the boundary conditions also include communication conditions between two or more control servers associated with the first and second zones.

[0145] Aspects of the above further comprises determining the extents of the first and second zones.

[0146] Aspects of the above include wherein a summation of all the zones equals the coverage area of the traffic control system.

[0147] Embodiments include methods, systems, devices, computer readable medium, computing systems, and/or means for providing navigation information for a control server, comprising: a vehicle control system, including a processor and associated with a traffic control system, receiving information; the vehicle control system analyzing the infor-

mation; the vehicle control system determining if a burst message is required based on the analysis; the vehicle control system forming the burst message; the vehicle control system sending, substantially simultaneously, the burst message to two or more vehicles.

[0148] Aspects of the above include wherein the burst message includes an identifier.

[0149] Aspects of the above include wherein the identifier applies to at least one of the two or more vehicles.

[0150] Aspects of the above include wherein at least one of the two or more vehicles recognizes the identifier as applying to the vehicle.

[0151] Aspects of the above include wherein the identifier is a general identifier.

[0152] Aspects of the above include wherein the burst message is broadcast to the two or more vehicles.

[0153] Aspects of the above include wherein the burst message is sent directly to a first vehicle and directly to a second vehicle.

[0154] Aspects of the above include wherein burst message is a general message that applies to at least one of the two or more vehicles.

[0155] Aspects of the above include wherein the information is information about an emergency or accident.

[0156] Aspects of the above include wherein the burst message directs at least on vehicle to avoid the emergency or accident.

[0157] Embodiments include methods, systems, devices, computer readable medium, computing systems, and/or means for providing navigation information for a control server of a traffic control system, comprising: a vehicle control system, including a processor, receiving first node information; the vehicle control system determining a node controller from the first node information; and the vehicle control system sending a node join request to the node controller of a node to join the node as a member.

[0158] Aspects of the above further comprises the vehicle control system receiving second node information in response to the node join request.

[0159] Aspects of the above further comprises the vehicle control system waiting instructions from the node controller as part of the node.

[0160] Aspects of the above include wherein the node controller is a second vehicle control system associated with a second vehicle.

[0161] Aspects of the above include wherein the first node information is provided by the control server associated with the traffic control system.

[0162] Aspects of the above include wherein the node controller receives the node join request.

[0163] Aspects of the above include wherein the node controller creates the second node information.

[0164] Aspects of the above include wherein the node controller sends the second node information.

[0165] Aspects of the above include wherein the node controller receives direction for the node from the control server.

[0166] Aspects of the above include wherein the node controller sends the received direction to members of the node.

[0167] Embodiments include methods, systems, devices, computer readable medium, computing systems, and/or means for providing navigation information for a control server, comprising: a control server, including a processor and associated with a traffic control system, receiving node information, from a node controller, about two or more mem-

bers of a node associated with the node information; the control server receiving consumer information for the two or more members of the node based on member information in the node information; the control server determining a similarity in the consumer information; and the control server matching advertising to the similarity.

[0168] Aspects of the above include wherein the similarity is associated with a common preferred product.

[0169] Aspects of the above include wherein the advertising is directed to the common preferred product.

[0170] Aspects of the above include wherein the consumer information is associated with two or more user profiles associated with the two or more members.

[0171] Aspects of the above include wherein the control server creates advertising to present to the node.

[0172] Aspects of the above include wherein the control server presents the advertising to the members of the node.

[0173] Aspects of the above include wherein the advertising is presented on an electronic billboard as the node passes the billboard.

[0174] Aspects of the above include wherein the advertising is presented on a user interface in two or more vehicles associated with the members of the node.

[0175] Aspects of the above include wherein the control server sends the advertising to the two or more vehicles to present on the user interface.

[0176] Aspects of the above include wherein the two or more members of the node are in spatial proximity to each other.

[0177] The present disclosure can provide a number of advantages depending on the particular aspect, embodiment, and/or configuration. The traffic control system includes processes for controlling automated vehicles that allows for denser traffic and safer travel. Without the problems associated with human drivers, the roadways governed by the traffic control system can move vehicles more efficiently and quicker. These and other advantages will be apparent from the disclosure.

[0178] The phrases “at least one,” “one or more,” and “and/or” are open-ended expressions that are both conjunctive and disjunctive in operation. For example, each of the expressions “at least one of A, B and C,” “at least one of A, B, or C,” “one or more of A, B, and C,” “one or more of A, B, or C” and “A, B, and/or C” means A alone, B alone, C alone, A and B together, A and C together, B and C together, or A, B and C together.

[0179] The term “a” or “an” entity refers to one or more of that entity. As such, the terms “a” (or “an”), “one or more,” and “at least one” can be used interchangeably herein. It is also to be noted that the terms “comprising,” “including,” and “having” can be used interchangeably.

[0180] The term “automatic” and variations thereof, as used herein, refer to any process or operation done without material human input when the process or operation is performed. However, a process or operation can be automatic, even though performance of the process or operation uses material or immaterial human input, if the input is received before the performance of the process or operation. Human input is deemed to be material if such input influences how the process or operation will be performed. Human input that consents to the performance of the process or operation is not deemed to be “material.”

[0181] The term “automotive navigation system” can refer to a satellite navigation system designed for use in vehicles. It

typically uses a GPS navigation device to acquire position data to locate the user on a road in the unit’s map database. Using the road database, the unit can give directions to other locations along roads also in its database. Dead reckoning using distance data from sensors attached to the drivetrain, a gyroscope and an accelerometer can be used for greater reliability, as GPS signal loss and/or multipath can occur due to urban canyons or tunnels.

[0182] The term “bus” and variations thereof, as used herein, can refer to a subsystem that transfers information and/or data between various components. A bus generally refers to the collection communication hardware interface, interconnects, bus architecture, standard, and/or protocol defining the communication scheme for a communication system and/or communication network. A bus may also refer to a part of a communication hardware that interfaces the communication hardware with the interconnects that connect to other components of the corresponding communication network. The bus may be for a wired network, such as a physical bus, or wireless network, such as part of an antenna or hardware that couples the communication hardware with the antenna. A bus architecture supports a defined format in which information and/or data is arranged when sent and received through a communication network. A protocol may define the format and rules of communication of a bus architecture.

[0183] The terms “communication device,” “smartphone,” and “mobile device,” and variations thereof, as used herein, can be used interchangeably and may include any type of device capable of communicating with one or more of another device and/or across a communications network, via a communications protocol, and the like. Exemplary communication devices may include but are not limited to smartphones, handheld computers, laptops, netbooks, notebook computers, subnotebooks, tablet computers, scanners, portable gaming devices, phones, pagers, GPS modules, portable music players, and other Internet-enabled and/or network-connected devices.

[0184] A “communication modality” can refer to any protocol- or standard defined or specific communication session or interaction, such as Voice-Over-Internet-Protocol (“VoIP”), cellular communications (e.g., IS-95, 1G, 2G, 3G, 3.5G, 4G, 4G/LTE-Advanced standards, 3GPP, WIMAX™, GSM, CDMA, CDMA2000, EDGE, 1xEVDO, iDEN, GPRS, HSPDA, TDMA, UMA, UMTS, ITU-R, and 5G), Bluetooth™, text or instant messaging (e.g., AIM, Blauk, eBuddy, Gadu-Gadu, IBM Lotus Sametime, ICQ, iMessage, IMVU, Lync, MXit, Paltalk, Skype, Tencent QQ, Windows Live Messenger™ or MSN Messenger™, Wireclub, Xfire, and Yahoo! Messenger™), email, Twitter (e.g., tweeting), Digital Service Protocol (DSP), and the like.

[0185] The term “communication system” or “communication network” and variations thereof, as used herein, can refer to a collection of communication components capable of one or more of transmission, relay, interconnect, control, or otherwise manipulate information or data from at least one transmitter to at least one receiver. As such, the communication may include a range of systems supporting point-to-point or broadcasting of the information or data. A communication system may refer to the collection individual communication hardware as well as the interconnects associated with and connecting the individual communication hardware. Communication hardware may refer to dedicated communication hardware or may refer a processor coupled with a communi-

cation means (i.e., an antenna) and running software capable of using the communication means to send and/or receive a signal within the communication system. Interconnect refers some type of wired or wireless communication link that connects various components, such as communication hardware, within a communication system. A communication network may refer to a specific setup of a communication system with the collection of individual communication hardware and interconnects having some definable network topography. A communication network may include wired and/or wireless network having a pre-set to an ad hoc network structure.

[0186] The term “computer-readable medium,” as used herein refers to any tangible storage and/or transmission medium that participates in providing instructions to a processor for execution. Such a medium may take many forms, including but not limited to, non-volatile media, volatile media, and transmission media. Non-volatile media includes, for example, non-volatile random access memory (NVRAM), or magnetic or optical disks. Volatile media includes dynamic memory, such as main memory. Common forms of computer-readable media include, for example, a floppy disk, a flexible disk, hard disk, magnetic tape, or any other magnetic medium, magneto-optical medium, a compact disc read only memory (CD-ROM), any other optical medium, punch cards, paper tape, any other physical medium with patterns of holes, a random access memory (RAM), a programmable read only memory (PROM), and erasable programmable read only memory EPROM, a FLASH-EPROM, a solid state medium like a memory card, any other memory chip or cartridge, a carrier wave as described hereinafter, or any other medium from which a computer can read. A digital file attachment to an e-mail or other self-contained information archive or set of archives is considered a distribution medium equivalent to a tangible storage medium. When the computer-readable media is configured as a database, it is to be understood that the database may be any type of database, such as relational, hierarchical, object-oriented, and/or the like. Accordingly, the disclosure is considered to include a tangible storage medium or distribution medium and prior art-recognized equivalents and successor media, in which the software implementations of the present disclosure are stored. It should be noted that any computer readable medium that is not a signal transmission may be considered non-transitory.

[0187] The terms dash and dashboard and variations thereof, as used herein, may be used interchangeably and can be any panel and/or area of a vehicle disposed adjacent to an operator, user, and/or passenger. Dashboards may include, but are not limited to, one or more control panel(s), instrument housing(s), head unit(s), indicator(s), gauge(s), meter (s), light(s), audio equipment, computer(s), screen(s), display (s), HUD unit(s), and graphical user interface(s).

[0188] The term “module” as used herein refers to any known or later developed hardware, software, firmware, artificial intelligence, fuzzy logic, or combination of hardware and software that is capable of performing the functionality associated with that element.

[0189] The term “desktop” refers to a metaphor used to portray systems. A desktop is generally considered a “surface” that may include pictures, called icons, widgets, folders, etc. that can activate and/or show applications, windows, cabinets, files, folders, documents, and other graphical items. The icons are generally selectable to initiate a task through

user interface interaction to allow a user to execute applications and/or conduct other operations.

[0190] The term “display” refers to a portion of a physical screen used to display the output of a computer to a user.

[0191] The term “displayed image” refers to an image produced on the display. A typical displayed image is a window or desktop. The displayed image may occupy all or a portion of the display.

[0192] The term “display orientation” refers to the way in which a rectangular display is oriented for viewing. The two most common types of display orientations are portrait and landscape. In landscape mode, the display is oriented such that the width of the display is greater than the height of the display (such as a 4:3 ratio, which is 4 units wide and 3 units tall, or a 16:9 ratio, which is 16 units wide and 9 units tall). Stated differently, the longer dimension of the display is oriented substantially horizontal in landscape mode while the shorter dimension of the display is oriented substantially vertical. In the portrait mode, by contrast, the display is oriented such that the width of the display is less than the height of the display. Stated differently, the shorter dimension of the display is oriented substantially horizontal in the portrait mode while the longer dimension of the display is oriented substantially vertical. A multi-screen display can have one composite display that encompasses all the screens. The composite display can have different display characteristics based on the various orientations of the device.

[0193] The term “electronic address” can refer to any contactable address, including a telephone number, instant message handle, e-mail address, Uniform Resource Locator (“URL”), Global Universal Identifier (“GUID”), Universal Resource Identifier (“URI”), Address of Record (“AOR”), electronic alias in a database, etc., combinations thereof.

[0194] The term “gesture” refers to a user action that expresses an intended idea, action, meaning, result, and/or outcome. The user action can include manipulating a device (e.g., opening or closing a device, changing a device orientation, moving a trackball or wheel, etc.), movement of a body part in relation to the device, movement of an implement or tool in relation to the device, audio inputs, etc. A gesture may be made on a device (such as on the screen) or with the device to interact with the device.

[0195] The term “gesture capture” refers to a sense or otherwise a detection of an instance and/or type of user gesture. The gesture capture can be received by sensors in three-dimensional space. Further, the gesture capture can occur in one or more areas of a screen, for example, on a touch-sensitive display or a gesture capture region. A gesture region can be on the display, where it may be referred to as a touch sensitive display, or off the display, where it may be referred to as a gesture capture area.

[0196] The terms “infotainment” and “infotainment system” may be used interchangeably and can refer to the hardware/software products, data, content, information, and/or systems, which can be built into or added to vehicles to enhance driver and/or passenger experience. Infotainment may provide media and/or multimedia content. An example is information-based media content or programming that also includes entertainment content.

[0197] A “multi-screen application” refers to an application that is capable of producing one or more windows that may simultaneously occupy one or more screens. A multi-screen application commonly can operate in single-screen mode in which one or more windows of the application are

displayed only on one screen or in multi-screen mode in which one or more windows are displayed simultaneously on multiple screens.

[0198] A “single-screen application” refers to an application that is capable of producing one or more windows that may occupy only a single screen at a time.

[0199] The terms “online community,” “e-community,” or “virtual community” can mean a group of people that interact via a computer network, for social, professional, educational, and/or other purposes. The interaction can use a variety of media formats, including wikis, blogs, chat rooms, Internet forums, instant messaging, email, and other forms of electronic media. Many media formats may be used in social software separately and/or in combination, including text-based chat rooms and forums that use voice, video text or avatars.

[0200] The term “satellite positioning system receiver” can refer to a wireless receiver or transceiver to receive and/or send location signals from and/or to a satellite positioning system (SPS), such as the Global Positioning System (“GPS”) (US), GLONASS (Russia), Galileo positioning system (EU), Compass navigation system (China), and Regional Navigational Satellite System (India).

[0201] The term “social network service” may include a service provider that builds online communities of people, who share interests and/or activities, or who are interested in exploring the interests and/or activities of others. Social network services can be network-based and may provide a variety of ways for users to interact, such as e-mail and instant messaging services.

[0202] The term “social network” can refer to a network-based social network.

[0203] The term “screen,” “touch screen,” “touchscreen,” or “touch-sensitive display” refers to a physical structure that enables the user to interact with the computer by touching areas on the screen and provides information to a user through a display. The touch screen may sense user contact in a number of different ways, such as by a change in an electrical parameter (e.g., resistance or capacitance), acoustic wave variations, infrared radiation proximity detection, light variation detection, and the like. In a resistive touch screen, for example, normally separated conductive and resistive metallic layers in the screen pass an electrical current. When a user touches the screen, the two layers make contact in the contacted location, whereby a change in electrical field is noted and the coordinates of the contacted location calculated. In a capacitive touch screen, a capacitive layer stores electrical charge, which is discharged to the user upon contact with the touch screen, causing a decrease in the charge of the capacitive layer. The decrease is measured, and the contacted location coordinates determined. In a surface acoustic wave touch screen, an acoustic wave is transmitted through the screen, and the acoustic wave is disturbed by user contact. A receiving transducer detects the user contact instance and determines the contacted location coordinates.

[0204] The term “window” refers to a, typically rectangular, displayed image on at least part of a display that contains or provides content different from the rest of the screen. The window may obscure the desktop. The dimensions and orientation of the window may be configurable either by another module or by a user. When the window is expanded, the window can occupy substantially all of the display space on a screen or screens.

[0205] The terms “determine,” “calculate,” and “compute,” and variations thereof, as used herein, are used interchangeably and include any type of methodology, process, mathematical operation, or technique.

[0206] It shall be understood that the term “means,” as used herein, shall be given its broadest possible interpretation in accordance with 35 U.S.C., Section 112, Paragraph 6 or other applicable law. Accordingly, a claim incorporating the term “means” shall cover all structures, materials, or acts set forth herein, and all of the equivalents thereof. Further, the structures, materials or acts and the equivalents thereof shall include all those described in the summary of the invention, brief description of the drawings, detailed description, abstract, and claims themselves.

[0207] The terms “vehicle,” “car,” “automobile,” and variations thereof may be used interchangeably herein and can refer to a device or structure for transporting animate and/or inanimate or tangible objects (e.g., persons and/or things), such as a self-propelled conveyance. A vehicle as used herein can include any conveyance or model of a conveyance, where the conveyance was originally designed for the purpose of moving one or more tangible objects, such as people, animals, cargo, and the like. The term “vehicle” does not require that a conveyance moves or is capable of movement. Typical vehicles may include but are in no way limited to cars, trucks, motorcycles, busses, automobiles, trains, railed conveyances, boats, ships, marine conveyances, submarine conveyances, airplanes, space craft, flying machines, human-powered conveyances, and the like.

[0208] The term “profile,” as used herein, can refer to any data structure, data store, and/or database that includes one or more items of information associated with a vehicle, a vehicle system, a device (e.g., a mobile device, laptop, mobile phone, etc.), or a person.

[0209] The term “in communication with,” as used herein, refers to any coupling, connection, or interaction using electrical signals to exchange information or data, using any system, hardware, software, protocol, or format, regardless of whether the exchange occurs wirelessly or over a wired connection.

[0210] The preceding is a simplified summary of the disclosure to provide an understanding of some aspects of the disclosure. This summary is neither an extensive nor exhaustive overview of the disclosure and its various aspects, embodiments, and/or configurations. It is intended neither to identify key or critical elements of the disclosure nor to delineate the scope of the disclosure but to present selected concepts of the disclosure in a simplified form as an introduction to the more detailed description presented below. As will be appreciated, other aspects, embodiments, and/or configurations of the disclosure are possible utilizing, alone or in combination, one or more of the features set forth above or described in detail below.

BRIEF DESCRIPTION OF THE DRAWINGS

[0211] FIG. 1 depicts an embodiment of a vehicle operating environment;

[0212] FIG. 2 is a block diagram of an embodiment of a vehicle system;

[0213] FIG. 3 is a block diagram of an embodiment of a vehicle control system environment;

[0214] FIG. 4 is a block diagram of an embodiment of a vehicle communications subsystem;

- [0215] FIG. 5A is a first block diagram of an embodiment of a vehicle interior environment separated into areas and/or zones;
- [0216] FIG. 5B is a second block diagram of an embodiment of a vehicle interior environment separated into areas and/or zones;
- [0217] FIG. 5C is a third block diagram of an embodiment of a vehicle interior environment separated into areas and/or zones;
- [0218] FIG. 6A depicts an embodiment of a sensor configuration for a vehicle;
- [0219] FIG. 6B depicts an embodiment of a sensor configuration for a zone of a vehicle;
- [0220] FIG. 7A is a block diagram of an embodiment of interior sensors for a vehicle;
- [0221] FIG. 7B is a block diagram of an embodiment of exterior sensors for a vehicle;
- [0222] FIG. 8A is a block diagram of an embodiment of a media subsystem for a vehicle;
- [0223] FIG. 8B is a block diagram of an embodiment of a user and device interaction subsystem for a vehicle;
- [0224] FIG. 8C is a block diagram of an embodiment of a Navigation subsystem for a vehicle;
- [0225] FIG. 9 is a block diagram of an embodiment of a communications subsystem for a vehicle;
- [0226] FIG. 10 is a block diagram of an embodiment of a software architecture for the vehicle control system;
- [0227] FIG. 11A is a graphical representation of an embodiment of a gesture that a user may perform to provide input to a vehicle control system;
- [0228] FIG. 11B is a graphical representation of an embodiment of a gesture that a user may perform to provide input to a vehicle control system;
- [0229] FIG. 11C is a graphical representation of an embodiment of a gesture that a user may perform to provide input to a vehicle control system;
- [0230] FIG. 11D is a graphical representation of an embodiment of a gesture that a user may perform to provide input to a vehicle control system;
- [0231] FIG. 11E is a graphical representation of an embodiment of a gesture that a user may perform to provide input to a vehicle control system;
- [0232] FIG. 11F is a graphical representation of an embodiment of a gesture that a user may perform to provide input to a vehicle control system;
- [0233] FIG. 11G is a graphical representation of an embodiment of a gesture that a user may perform to provide input to a vehicle control system;
- [0234] FIG. 11H is a graphical representation of an embodiment of a gesture that a user may perform to provide input to a vehicle control system;
- [0235] FIG. 11I is a graphical representation of an embodiment of a gesture that a user may perform to provide input to a vehicle control system;
- [0236] FIG. 11J is a graphical representation of an embodiment of a gesture that a user may perform to provide input to a vehicle control system;
- [0237] FIG. 11K is a graphical representation of an embodiment of a gesture that a user may perform to provide input to a vehicle control system;
- [0238] FIG. 12A is a diagram of an embodiment of a data structure for storing information about a user of a vehicle;
- [0239] FIG. 12B is a diagram of an embodiment of a data structure for storing information about a device associated with or in a vehicle;
- [0240] FIG. 12C is a diagram of an embodiment of a data structure for storing information about a system of a vehicle;
- [0241] FIG. 12D is a diagram of an embodiment of a data structure for storing information about a vehicle;
- [0242] FIG. 13 is a flow or process diagram of a method for storing one or more settings associated with a user;
- [0243] FIG. 14 is a flow or process diagram of a method for establishing one or more settings associated with a user;
- [0244] FIG. 15 is a flow or process diagram of a method for storing one or more settings associated with a user;
- [0245] FIG. 16 is a flow or process diagram of a method for storing one or more gestures associated with a user;
- [0246] FIG. 17 is a flow or process diagram of a method for reacting to a gesture performed by a user;
- [0247] FIG. 18 is a flow or process diagram of a method for storing health data associated with a user;
- [0248] FIG. 19 is a flow or process diagram of a method for reacting to a gesture performed by a user;
- [0249] FIG. 20 is a block diagram of an embodiment of a traffic control system;
- [0250] FIG. 21 is a block diagram of an embodiment of a control server;
- [0251] FIG. 22 is a block diagram of an embodiment of a traffic controller;
- [0252] FIG. 23 is a diagram of an embodiment of a data structure for storing, retrieving, or communicating data within the traffic control system;
- [0253] FIG. 24 is another diagram of an embodiment of a data structure for storing, retrieving, or communicating data within the traffic control system;
- [0254] FIG. 25 is another diagram of an embodiment of a data structure for storing, retrieving, or communicating data within the traffic control system;
- [0255] FIG. 26 is another diagram of an embodiment of a data structure for storing, retrieving, or communicating data within the traffic control system;
- [0256] FIG. 27 is another diagram of an embodiment of a data structure for storing, retrieving, or communicating data within the traffic control system;
- [0257] FIG. 28 is another diagram of an embodiment of a data structure for storing, retrieving, or communicating data within the traffic control system;
- [0258] FIG. 29 is another diagram of an embodiment of a data structure for storing, retrieving, or communicating data within the traffic control system;
- [0259] FIG. 30 is a flow or process diagram of a method for controlling traffic in a traffic control system;
- [0260] FIG. 31 is a flow or process diagram of a method for registering a vehicle in a traffic control system;
- [0261] FIG. 32 is a flow or process diagram of a method for sending active and passive messages in a traffic control system;
- [0262] FIG. 33 is a flow or process diagram of a method for sending a burst message in a traffic control system;
- [0263] FIG. 34A is a flow or process diagram of a method for sending a message in a traffic control system;
- [0264] FIG. 34B is a flow or process diagram of a method for receiving a message in a traffic control system;
- [0265] FIG. 35 is a flow or process diagram of a method for conducting a zone handoff in a traffic control system;

[0266] FIG. 36 is a flow or process diagram of a method for creating zones in a traffic control system;

[0267] FIG. 37 is a flow or process diagram of a method for responding to an emergency in a traffic control system;

[0268] FIG. 38 is a flow or process diagram of a method for responding to an emergency in a traffic control system;

[0269] FIG. 39 is a flow or process diagram of a method for conducting a failover in a traffic control system;

[0270] FIG. 40 is a flow or process diagram of a method for consolidating traffic in a traffic control system;

[0271] FIG. 41 is a flow or process diagram of a method for creating nodes in a traffic control system;

[0272] FIG. 42 is a flow or process diagram of a method for advertising to nodes in a traffic control system;

[0273] FIG. 43 is a block diagram of an embodiment of a computing system environment;

[0274] FIG. 44 is a block diagram of an embodiment of a computing system.

[0275] In the appended figures, similar components and/or features may have the same reference label. Further, various components of the same type may be distinguished by following the reference label by a letter that distinguishes among the similar components. If only the first reference label is used in the specification, the description is applicable to any one of the similar components having the same first reference label irrespective of the second reference letter or label.

DETAILED DESCRIPTION

[0276] Presented herein are embodiments of systems, devices, processes, data structures, user interfaces, etc. The embodiments may relate to an automobile and/or an automobile environment. The automobile environment can include systems associated with the automobile and devices or other systems in communication with the automobile and/or automobile systems. Furthermore, the systems can relate to communications systems and/or devices and may be capable of communicating with other devices and/or to an individual or group of individuals. Further, the systems can receive user input in unique ways. The overall design and functionality of the systems provide for an enhanced user experience making the automobile more useful and more efficient. As described herein, the automobile systems may be electrical, mechanical, electro-mechanical, software-based, and/or combinations thereof.

[0277] A vehicle environment 100 that may contain a vehicle ecosystem is shown in FIG. 1. The vehicle environment 100 can contain areas associated with a vehicle or conveyance 104. The vehicle 104 is shown as a car but can be any type of conveyance. The environment 100 can include at least three zones. A first zone 108 may be inside a vehicle 104. The zone 108 includes any interior space, trunk space, engine compartment, or other associated space within or associated with the vehicle 104. The interior zone 108 can be defined by one or more techniques, for example, geo-fencing.

[0278] A second zone 112 may be delineated by line 120. The zone 112 is created by a range of one or more sensors associated with the vehicle 104. Thus, the area 112 is exemplary of the range of those sensors and what can be detected by those sensors associated with the vehicle 104. Although sensor range is shown as a fixed and continuous oval, the sensor range may be dynamic and/or discontinuous. For example, a ranging sensor (e.g., radar, lidar, ladar, etc.) may provide a variable range depending on output power, signal characteristics, or environmental conditions (e.g., rain, fog,

clear, etc.). The rest of the environment includes all space beyond the range of the sensors and is represented by space 116. Thus, the environment 100 may have an area 116 that includes all areas beyond the sensor range 112. The area 116 may include locations of travel that the vehicle 104 may proceed to in the future.

[0279] An embodiment of a vehicle system 200 is shown in FIG. 2. The vehicle system 200 may comprise hardware and/or software that conduct various operations for or with the vehicle 104. The operations can include, but are not limited to, providing information to the user 216, receiving input from the user 216, and controlling the functions or operation of the vehicle 104, etc. The vehicle system 200 can include a vehicle control system 204. The vehicle control system 204 can be any type of computing system operable to conduct the operations as described herein. An example of a vehicle control system may be as described in conjunction with FIG. 3.

[0280] The vehicle control system 204 may interact with a memory or storage system 208 that stores system data. System data 208 may be any type of data needed for the vehicle control system 204 to control effectively the vehicle 104. The system data 208 can represent any type of database or other storage system. Thus, the system data 208 can be a flat file data system, an object-oriented data system, or some other data system that may interface with the vehicle control system 204.

[0281] The vehicle control system 204 may communicate with a device or user interface 212, 248. The user interface 212, 248 may be operable to receive user input either through touch input, on one or more user interface buttons, via voice command, via one or more image sensors, or through a graphical user interface that may include a gesture capture region, as described in conjunction with the other figures provided herein. Further, the symbol 212, 248 can represent a device that is located or associated with the vehicle 104. The device 212, 248 can be a mobile device, including, but not limited to, a mobile telephone, a mobile computer, or other type of computing system or device that is either permanently located in or temporarily associated with, but not necessarily connected to, the vehicle 104. Thus, the vehicle control system 204 can interface with the device 212, 248 and leverage the device's computing capability to provide one or more of the features or functions as described herein.

[0282] The device or user interface 212, 248 can receive input or provide information to a user 216. The user 216 may thus interact with the vehicle control system 204 through the interface or device 212, 248. Further, the device 212, 248 may include or have access to device data 220 and/or profile data 252. The device data 220 can be any type of data that is used in conjunction with the device 212, 248 including, but not limited to, multimedia data, preferences data, device identification information, or other types of data. The profile data 252 can be any type of data associated with at least one user 216 including, but in no way limited to, bioinformatics, medical information, driving history, personal information (e.g., home physical address, business physical address, contact addresses, likes, dislikes, hobbies, size, weight, occupation, business contacts—including physical and/or electronic addresses, personal contacts—including physical and/or electronic addresses, family members, and personal information related thereto, etc.), other user characteristics, advertising information, user settings and feature preferences, travel information, associated vehicle preferences, communication preferences, historical information (e.g., including historical,

current, and/or future travel destinations), Internet browsing history, or other types of data. In any event, the data may be stored as device data **220** and/or profile data **252** in a storage system similar to that described in conjunction with FIGS. **12A** through **12D**.

[0283] As an example, the profile data **252** may include one or more user profiles. User profiles may be generated based on data gathered from one or more of vehicle preferences (e.g., seat settings, HVAC settings, dash configurations, and the like), recorded settings, geographic location information (e.g., provided by a satellite positioning system (e.g., GPS), Wi-Fi hotspot, cell tower data, etc.), mobile device information (such as mobile device electronic addresses, Internet browsing history and content, application store selections, user settings and enabled and disabled features, and the like), private information (such as user information from a social network, user presence information, user business account, and the like), secure data, biometric information, audio information from on board microphones, video information from on board cameras, Internet browsing history and browsed content using an on board computer and/or the local area network enabled by the vehicle **104**, geographic location information (e.g., a vendor storefront, roadway name, city name, etc.), and the like.

[0284] The profile data **252** may include one or more user accounts. User accounts may include access and permissions to one or more settings and/or feature preferences associated with the vehicle **104**, communications, infotainment, content, etc. In one example, a user account may allow access to certain settings for a particular user, while another user account may deny access to the settings for another user, and vice versa. The access controlled by the user account may be based on at least one of a user account priority, role, permission, age, family status, a group priority (e.g., the user account priority of one or more users, etc.), a group age (e.g., the average age of users in the group, a minimum age of the users in the group, a maximum age of the users in the group, and/or combinations thereof, etc.).

[0285] For example, a user **216** may be allowed to purchase applications (e.g., software, etc.) for the vehicle **104** and/or a device associated with the vehicle **104** based on information associated with the user account. This user account information may include a preferred payment method, permissions, and/or other account information. As provided herein, the user account information may be part of the user profile and/or other data stored in the profile data **252**.

[0286] As another example, an adult user (e.g., a user with an age of 18 years old and/or over, etc.) may be located in an area of a vehicle **104**, such as a rear passenger area. Continuing this example a child user (e.g., a user with an age of 17 years old and/or less, etc.) may be located in the same, or close, area. In this example, the user account information in the profile data **252** associated with both the adult user and the child user may be used by the vehicle **104** in determining whether content is appropriate for the area given the age of the child user. For instance, a graphic movie containing violence (e.g., a movie associated with a mature rating, such as a Motion Picture Association of America (MPAA) rating of "R," "NC-17," etc.) may be suitable to present to a display device associated with the adult user but may not be acceptable to present to the display device if a 12-year old child user may see and/or hear the content of the movie.

[0287] The vehicle control system **204** may also communicate with or through a communication network **224**. The

communication network **224** can represent any type of wireless and/or wired communication system that may be included within the vehicle **104** or operable to communicate outside the vehicle **104**. Thus, the communication network **224** can include a local area communication capability and a wide area communication capability. For example, the communication network **224** can include a Bluetooth® wireless system, an 802.11x (e.g., 802.11G/802.11N/802.11AC, or the like, wireless system), a CAN bus, an Ethernet network within the vehicle **104**, or other types of communication networks that may function with or be associated with the vehicle **104**. Further, the communication network **224** can also include wide area communication capabilities, including one or more of, but not limited to, a cellular communication capability, satellite telephone communication capability, a wireless wide area network communication capability, or other types of communication capabilities that allow for the vehicle control system **204** to communicate outside the vehicle **104**.

[0288] The vehicle control system **204** may communicate through the communication network **224** to a server **228** that may be located in a facility that is not within physical proximity to the vehicle **104**. Thus, the server **228** may represent a cloud computing system or cloud storage that allows the vehicle control system **204** to either gain access to further computing capabilities or to storage at a location outside of the vehicle **104**. The server **228** can include a computer processor and memory and be similar to any computing system as understood to one skilled in the art.

[0289] Further, the server **228** may be associated with stored data **232**. The stored data **232** may be stored in any system or by any method, as described in conjunction with system data **208**, device data **220**, and/or profile data **252**. The stored data **232** can include information that may be associated with one or more users **216** or associated with one or more vehicles **104**. The stored data **232**, being stored in a cloud or in a distant facility, may be exchanged among vehicles **104** or may be used by a user **216** in different locations or with different vehicles **104**. Additionally or alternatively, the server may be associated with profile data **252** as provided herein. It is anticipated that the profile data **252** may be accessed across the communication network **224** by one or more components of the system **200**. Similar to the stored data **232**, the profile data **252**, being stored in a cloud or in a distant facility, may be exchanged among vehicles **104** or may be used by a user **216** in different locations or with different vehicles **104**.

[0290] The vehicle control system **204** may also communicate with one or more sensors **236**, **242**, which are either associated with the vehicle **104** or communicate with the vehicle **104**. Vehicle sensors **242** may include one or more sensors for providing information to the vehicle control system **204** that determine or provide information about the environment **100** in which the vehicle **104** is operating. Embodiments of these sensors may be as described in conjunction with FIGS. **6A-7B**. Non-vehicle sensor **236** can be any type of sensor that is not currently associated with the vehicle **104**. For example, non-vehicle sensor **236** can be sensors in a traffic system operated by a third party that provides data to the vehicle control system **204**. Further, the non-vehicle sensor(s) **236** can be other types of sensors which provide information about the distant environment **116** or other information about the vehicle **104** or the environment **100**. These non-vehicle sensors **236** may be operated by third

parties but provide information to the vehicle control system **204**. Examples of information provided by the sensors **236** and that may be used by the vehicle control system **204** may include weather tracking data, traffic data, user health tracking data, vehicle maintenance data, or other types of data, which may provide environmental or other data to the vehicle control system **204**. The vehicle control system **204** may also perform signal processing of signals received from one or more sensors **236**, **242**. Such signal processing may include estimation of a measured parameter from a single sensor, such as multiple measurements of a range state parameter from the vehicle **104** to an obstacle, and/or the estimation, blending, or fusion of a measured state parameter from multiple sensors such as multiple radar sensors or a combination of a lidar/lidar range sensor and a radar sensor. Signal processing of such sensor signal measurements may comprise stochastic signal processing, adaptive signal processing, and/or other signal processing techniques known to those skilled in the art.

[0291] The various sensors **236**, **242** may include one or more sensor memory **244**. Embodiments of the sensor memory **244** may be configured to store data collected by the sensors **236**, **242**. For example, a temperature sensor may collect temperature data associated with a vehicle **104**, user **216**, and/or environment, over time. The temperature data may be collected incrementally, in response to a condition, or at specific time periods. In this example, as the temperature data is collected, it may be stored in the sensor memory **244**. In some cases, the data may be stored along with an identification of the sensor and a collection time associated with the data. Among other things, this stored data may include multiple data points and may be used to track changes in sensor measurements over time. As can be appreciated, the sensor memory **244** can represent any type of database or other storage system.

[0292] The diagnostic communications module **256** may be configured to receive and transmit diagnostic signals and information associated with the vehicle **104**. Examples of diagnostics signals and information may include, but is in no way limited to, vehicle system warnings, sensor data, vehicle component status, service information, component health, maintenance alerts, recall notifications, predictive analysis, and the like. Embodiments of the diagnostic communications module **256** may handle warning/error signals in a predetermined manner. The signals, for instance, can be presented to one or more of a third party, occupant, vehicle control system **204**, and a service provider (e.g., manufacturer, repair facility, etc.).

[0293] Optionally, the diagnostic communications module **256** may be utilized by a third party (i.e., a party other than the user **216**, etc.) in communicating vehicle diagnostic information. For instance, a manufacturer may send a signal to a vehicle **104** to determine a status associated with one or more components associated with the vehicle **104**. In response to receiving the signal, the diagnostic communications module **256** may communicate with the vehicle control system **204** to initiate a diagnostic status check. Once the diagnostic status check is performed, the information may be sent via the diagnostic communications module **256** to the manufacturer. This example may be especially useful in determining whether a component recall should be issued based on the status check responses returned from a certain number of vehicles.

[0294] Wired/wireless transceiver/communications ports **260** may be included. The wired/wireless transceiver/com-

munications ports **260** may be included to support communications over wired networks or links, for example with other communication devices, server devices, and/or peripheral devices. Examples of wired/wireless transceiver/communications ports **260** include Ethernet ports, Universal Serial Bus (USB) ports, Institute of Electrical and Electronics Engineers (IEEE) 1594, or other interface ports.

[0295] An embodiment of a vehicle control environment **300** including a vehicle control system **204** may be as shown in FIG. 3. Beyond the vehicle control system **204**, the vehicle control environment **300** can include one or more of, but is not limited to, a power source and/or power control module **316**, a data storage module **320**, user interface(s)/input interface(s) **324**, vehicle subsystems **328**, user interaction subsystems **332**, Global Positioning System (GPS)/Navigation subsystems **336**, sensor(s) and/or sensor subsystems **340**, communication subsystems **344**, media subsystems **348**, and/or device interaction subsystems **352**. The subsystems, modules, components, etc. **316-352** may include hardware, software, firmware, computer readable media, displays, input devices, output devices, etc. or combinations thereof. The system, subsystems, modules, components, etc. **204**, **316-352** may communicate over a network or bus **356**. This communication bus **356** may be bidirectional and perform data communications using any known or future-developed standard or protocol. An example of the communication bus **356** may be as described in conjunction with FIG. 4.

[0296] The vehicle control system **204** can include a processor **304**, memory **308**, and/or an input/output (I/O) module **312**. Thus, the vehicle control system **204** may be a computer system, which can comprise hardware elements that may be electrically coupled. The hardware elements may include one or more central processing units (CPUs) **304**; one or more components of the I/O module **312** including input devices (e.g., a mouse, a keyboard, etc.) and/or one or more output devices (e.g., a display device, a printer, etc.).

[0297] The processor **304** may comprise a general purpose programmable processor or controller for executing application programming or instructions. The processor **304** may, optionally, include multiple processor cores, and/or implement multiple virtual processors. Additionally or alternatively, the processor **304** may include multiple physical processors. As a particular example, the processor **304** may comprise a specially configured application specific integrated circuit (ASIC) or other integrated circuit, a digital signal processor, a controller, a hardwired electronic or logic circuit, a programmable logic device or gate array, a special purpose computer, or the like. The processor **304** generally functions to run programming code or instructions implementing various functions of the vehicle control system **204**.

[0298] The input/output module **312** and associated ports may be included to support communications over wired or wireless networks or links, for example with other communication devices, server devices, and/or peripheral devices. Examples of an input/output module **312** include an Ethernet port, a Universal Serial Bus (USB) port, Institute of Electrical and Electronics Engineers (IEEE) 1594, or other interface.

[0299] The vehicle control system **204** may also include one or more storage devices **308**. By way of example, storage devices **308** may be disk drives, optical storage devices, solid-state storage devices such as a random access memory ("RAM") and/or a read-only memory ("ROM"), which can be programmable, flash-updateable and/or the like. The vehicle control system **204** may additionally include a com-

puter-readable storage media reader; a communications system (e.g., a modem, a network card (wireless or wired), an infra-red communication device, etc.); and working memory 308, which may include RAM and ROM devices as described above. The vehicle control system 204 may also include a processing acceleration unit, which can include a digital signal processor (DSP), a special-purpose processor, and/or the like.

[0300] The computer-readable storage media reader can further be connected to a computer-readable storage medium, together (and, optionally, in combination with storage device (s)) comprehensively representing remote, local, fixed, and/or removable storage devices plus storage media for temporarily and/or more permanently containing computer-readable information. The communications system may permit data to be exchanged with an external or internal network and/or any other computer or device described herein. Moreover, as disclosed herein, the term “storage medium” may represent one or more devices for storing data, including read only memory (ROM), random access memory (RAM), magnetic RAM, core memory, magnetic disk storage mediums, optical storage mediums, flash memory devices, and/or other machine readable mediums for storing information.

[0301] The vehicle control system 204 may also comprise software elements including an operating system and/or other code, as described in conjunction with FIG. 10. It should be appreciated that alternates to the vehicle control system 204 may have numerous variations from that described herein. For example, customized hardware might also be used and/or particular elements might be implemented in hardware, software (including portable software, such as applets), or both. Further, connection to other computing devices such as network input/output devices may be employed.

[0302] The power source and/or power control module 316 can include any type of power source, including, but not limited to, batteries, alternating current sources (from connections to a building power system or power line), solar cell arrays, etc. One or more components or modules may also be included to control the power source or change the characteristics of the provided power signal. Such modules can include one or more of, but is not limited to, power regulators, power filters, alternating current (AC) to direct current (DC) converters, DC to AC converters, receptacles, wiring, other converters, etc. The power source and/or power control module 316 functions to provide the vehicle control system 204 and any other system with power.

[0303] The data storage 320 can include any module for storing, retrieving, and/or managing data in one or more data stores and/or databases. The database or data stores may reside on a storage medium local to (and/or resident in) the vehicle control system 204 or in the vehicle 104. Alternatively, some of the data storage capability may be remote from the vehicle control system 204 or automobile, and in communication (e.g., via a network) to the vehicle control system 204. The database or data stores may reside in a storage-area network (“SAN”) familiar to those skilled in the art. Similarly, any necessary files for performing the functions attributed to the vehicle control system 204 may be stored locally on the respective vehicle control system 204 and/or remotely, as appropriate. The databases or data stores may be a relational database, and the data storage module 320 may be adapted to store, update, and retrieve data in response to specifically-formatted commands. The data storage module

320 may also perform data management functions for any flat file, object oriented, or other type of database or data store.

[0304] A first data store that may be part of the vehicle control environment 300 is a profile data store 252 for storing data about user profiles and data associated with the users. A system data store 208 can include data used by the vehicle control system 204 and/or one or more of the components 324-352 to facilitate the functionality described herein. The data stores 208 and/or 252 may be as described in conjunction with FIGS. 1 and/or 12A-12D.

[0305] The user interface/input interfaces 324 may be as described herein for providing information or data and/or for receiving input or data from a user. Vehicle systems 328 can include any of the mechanical, electrical, electromechanical, computer, or other systems associated with the function of the vehicle 100. For example, vehicle systems 328 can include one or more of, but is not limited to, the steering system, the braking system, the engine and engine control systems, the electrical system, the suspension, the drive train, the cruise control system, the radio, the heating, ventilation, air conditioning (HVAC) system, the windows and/or doors, etc. These systems are well known in the art and will not be described further.

[0306] Examples of the other systems and subsystems 324-352 may be as described further herein. For example, the user interface(s)/input interface(s) 324 may be as described in FIGS. 2 and 8B; the vehicle subsystems 328 may be as described in FIGS. 6a et. seq.; the user interaction subsystem 332 may be as described in conjunction with the user/device interaction subsystem 817 of FIG. 8B; the Navigation subsystem 336 may be as described in FIGS. 6A and 8C; the sensor(s)/sensor subsystem 340 may be as described in FIGS. 7A and 7B; the communication subsystem 344 may be as described in FIGS. 2, 4, 5B, 5C, and 9; the media subsystem 348 may be as described in FIG. 8A; and, the device interaction subsystem 352 may be as described in FIG. 2 and in conjunction with the user/device interaction subsystem 817 of FIG. 8B.

[0307] FIG. 4 illustrates an optional communications channel architecture 400 and associated communications components. FIG. 4 illustrates some of the optional components that can be interconnected via the communication channels/zones 404. Communication channels/zones 404 can carry information on one or more of a wired and/or wireless communications link with, in the illustrated example, there being three communications channels/zones, 408, 412, and 416.

[0308] This optional environment 400 can also include an IP router 420, an operator cluster 424, one or more storage devices 428, one or more blades, such as master blade 432, and computational blades 436 and 440. Additionally, the communications channels/zones 404 can interconnect one or more displays, such as, remote display 1 444, remote display N 448, and console display 452. The communications channels/zones 404 also interconnect an access point 456, a Bluetooth® access point/USB hub 460, a Femtocell 464, a storage controller 468, that is connected to one or more of USB devices 472, DVDs 476, or other storage devices 480. To assist with managing communications within the communication channel, the environment 400 optionally includes a firewall 484 which will be discussed hereinafter in greater detail. Other components that could also share the communications channel/zones 404 include GPS 488, media controller 492, which is connected to one or more media sources 496, and one or more subsystems, such as subsystem switches 498.

[0309] Optionally, the communications channels/zones **404** can be viewed as an I/O network or bus where the communications channels are carried on the same physical media. Optionally, the communication channels **404** can be split amongst one or more physical media and/or combined with one or more wireless communications protocols. Optionally, the communications channels **404** can be based on wireless protocols with no physical media interconnecting the various elements described herein.

[0310] The environment **400** shown in FIG. 4 can include a collection of blade processors that are housed in a “crate.” The crate can have a PC-style backplane connector **408** and a backplane Ethernet **408** that allows the various blades to communicate with one another using, for example, an Ethernet.

[0311] Various other functional elements illustrated in FIG. 4 can be integrated into this crate architecture with, as discussed hereinafter, various zones utilized for security. Optionally, as illustrated in FIG. 4, the backplane **404/408** can have two separate Ethernet zones that may or may not be on the same communications channel. Optionally, the zones exist on a single communications channel on the I/O network/bus **408**. Optionally, the zones are actually on different communications channels, e.g., **412, 416**; however, the implementation is not restricted to any particular type of configuration. Rather, as illustrated in FIG. 4, there can be a red zone **417** and a green zone **413**, and the I/O backplane on the network/bus **408** that enables standard I/O operations. This backplane or I/O network/bus **408** also optionally can provide power distribution to the various modules and blades illustrated in FIG. 4. The red and green Ethernet zones, **417** and **413** respectively, can be implemented as Ethernet switches, with one on each side of the firewall **484**. Two Ethernets (untrusted and trusted) are not connected in accordance with an optional embodiment. Optionally, the connector geometry for the firewall can be different for the Ethernet zones than for the blades that are a part of the system.

[0312] The red zone **417** only needs to go from the modular connector to the input side of the backplane connector of the firewall **484**. While FIG. 4 indicates that there are five external red zone connectors to the firewall **484**, provisions can be made for any number of ports with the connections being made at the access point **456**, the Bluetooth® access point (combo controller) **460**, Femtocell **464**, storage controller **468**, and/or firewall **484**. Optionally, the external port connections can be made through a manufacturer configurable modular connector panel, and one or more of the red zone Ethernet ports could be available through a customer supplied crate which allows, for example, wired Ethernet connections from a bring-your-own-device (BYOD) to the firewall **484**.

[0313] The green zone **413** goes from the output side of the firewall **484** and generally defines the trusted Ethernet. The Ethernet on the backplane **408** essentially implements an Ethernet switch for the entire system, defining the Ethernet backbone of the vehicle **104**. All other modules, e.g., blades, etc., can connect to a standard backplane bus and the trusted Ethernet. Some number of switch ports can be reserved to connect to an output modular connector panel to distribute the Ethernet throughout the vehicle **104**, e.g., connecting such elements as the console display **452**, remote displays **444, 448**, GPS **488**, etc. Optionally, only trusted components, either provided or approved by the manufacturer after testing, can be attached to the green zone **413**, which is by definition in the trusted Ethernet environment.

[0314] Optionally, the environment **400**, shown in FIG. 4, utilizes IPv6 over Ethernet connections wherever possible. Using, for example, the Broadcom single-twisted pair Ethernet technology, wiring harnesses are simplified and data transmission speeds are maximized. However, while the Broadcom single-twisted pair Ethernet technology can be used, in general, systems and methods can work comparably well with any type of well-known Ethernet technology or other comparable communications technology.

[0315] As illustrated in FIG. 4 the I/O network/bus **408** is a split-bus concept that contains three independent bus structures:

[0316] The red zone **417**—the untrusted Ethernet environment. This zone **417** may be used to connect network devices and customer provided devices to the vehicle information system with these devices being on the untrusted side of the firewall **484**.

[0317] The green zone **413**—the trusted Ethernet environment, this zone **413** can be used to connect manufacturer certified devices such as GPS units, remote displays, subsystem switches, and the like, to the vehicle network **404**. Manufacturer certified devices can be implemented by vendors that allow the vehicle software system to validate whether or not a device is certified to operate with the vehicle **100**. Optionally, only certified devices are allowed to connect to the trusted side of the network.

[0318] The I/O bus **409**—the I/O bus may be used to provide power and data transmission to bus-based devices such as the vehicle solid state drive, the media controller blade **492**, the computational blades **436, 440**, and the like.

[0319] As an example, the split-bus structure can have the following minimum configuration:

[0320] Two slots for the red zone Ethernet;

[0321] One slot for built-in LTE/WiMax access **420** from the car to other network resources such as the cloud/Internet;

[0322] One slot for user devices or bring-your-own device access, this slot can implement, for example, WiFi, Bluetooth®, and/or USB connectivity **456**, which can be provided in, for example, the customer crate;

[0323] One slot for combined red zone and green zone Ethernet, this slot can be reserved for the firewall controller;

[0324] Two slots for computational blades. Here, the two computation blades are illustratively as shown the optional master blade and the multimedia blade or controller **492** which can be provided as standard equipment; and

[0325] The expansion controller that allows the I/O bus to be extended and provides additional Ethernet switch ports for one or more of the red or green zones, which may require that the basic green zone Ethernet switch implementation will support additional ports beyond the initial three that are needed for the basic exemplary system.

[0326] It should be possible to build 8 or 16 or more Ethernet switches that allow for the expansion with existing component(s) in a straight-forward manner.

[0327] The red zone **417** can be implemented as an 8-port Ethernet switch that has three actual bus ports within the crate with the remaining five ports being available on the customer crate. The crate implements red zone slots for the firewall

controller **484**, the combo controller which includes WiFi, Bluetooth®, USB hub (**456**, **460**) and the IP router **420**.

[0328] The firewall controller **484** can have a dedicated slot that bridges the red zone **417**, green zone **413**, and uses the I/O bus for power connections. In accordance with an optional low cost implementation, the firewall **484** can be implemented by a dummy module that simply bridges the red zone **417** and the green zone **413** without necessarily providing any firewall functionality. The combo controller **460** that includes the WiFi, Bluetooth®, and USB hub can be provided for consumer device connections. This controller can also implement the IPv6 (un-routable) protocol to ensure that all information is packetized for transmission via IP over the Ethernet in the I/O network/bus **408**.

[0329] The combo controller **460** with the USB hub can have ports in the customer crate. The combo controller **460** can implement USB discovery functions and packetizes the information for transmission via IP over Ethernet. The combo controller **460** can also facilitate installation of the correct USB driver for the discovered device, such as a BYOD from the user. The combo controller **460** and USB hub can then map the USB address to a “local” IPv6 address for interaction with one or more of the computational blades which is generally going to be the media controller **492**.

[0330] The IP router **420** can implement Internet access through a manufacturer provided service. This service can allow, for example, a manufacturer to offer value-added services to be integrated into the vehicle information systems. The existence of the manufacturer provided Internet access can also allow the “e-Call” function and other vehicle data recorder functions to be implemented. IP router **420** also allows, for example, WiMax, 4G LTE, and other connections to the Internet through a service provider that can be, for example, contracted by the manufacturer. Internally, the IP router **420** can allow cellular handset connections to the Internet through a Femtocell **464** that is part of the IP router implementation. The IP router **420**, with the Femtocell **464**, can also allow a cone of silence functionality to be implemented. The IP router **420** can be an optional component for a vehicle provided by, for example, the manufacturer, a dealer, or installed by a user. In the absence of the IP router **420**, it is possible to connect a consumer handheld device to the I/O network/bus **408** using, for example, either WiFi or Bluetooth® **456**, **460**. While functionality may be somewhat reduced when using a handheld device instead of a built-in Ethernet connection, systems and methods of this invention can also work utilizing this consumer handheld device which then connects to the Internet via, for example, WiMax, 4G, 4G LTE, or the like.

[0331] FIGS. 5A-5C show configurations of a vehicle **104**. In general, a vehicle **104** may provide functionality based at least partially on one or more areas, zones, and distances, associated with the vehicle **104**. Non-limiting examples of this functionality are provided herein below.

[0332] An arrangement or configuration for sensors within a vehicle **104** is as shown in FIG. 5A. The sensor arrangement **500** can include one or more areas **508** within the vehicle. An area can be a larger part of the environment inside or outside of the vehicle **104**. Thus, area one **508A** may include the area within the trunk space or engine space of the vehicle **104** and/or the front passenger compartment. Area two **508B** may include a portion of the interior space **108** (e.g., a passenger compartment, etc.) of the vehicle **104**. The area N, **508N**, may include the trunk space or rear compartment area, when

included within the vehicle **104**. The interior space **108** may also be divided into other areas. Thus, one area may be associated with the front passenger’s and driver’s seats, a second area may be associated with the middle passengers’ seats, and a third area may be associated with a rear passenger’s seat. Each area **508** may include one or more sensors that are positioned or operate to provide environmental information about that area **508**.

[0333] Each area **508** may be further separated into one or more zones **512** within the area **508**. For example, area **1508A** may be separated into zone A **512A**, and zone B **512B**. Each zone **512** may be associated with a particular portion of the interior occupied by a passenger. For example, zone A **512A** may be associated with a driver. Zone B **512B**, may be associated with a front passenger. Each zone **512** may include one or more sensors that are positioned or configured to collect information about the environment or ecosystem associated with that zone or person.

[0334] A passenger area **508B** may include more than two zones as described in conjunction with area **508A**. For example, area **508B** may include three zones, **512C**, **512D**, and **512E**. These three separate zones **512C**, **512D**, and **512E** may be associated with three passenger seats typically found in the rear passenger area of a vehicle **104**. An area **508N** and may include a single zone **512N** as there may be no separate passenger areas but may include a single trunk area within the vehicle **104**. The number of zones **512** is unlimited within the areas as the areas are also unlimited inside the vehicle **104**. Further, it should be noted that there may be one or areas **508** or zones **512** that may be located outside the vehicle **104** that may have a specific set of sensors associated therewith.

[0335] Optionally, each area/access point **508**, **456**, **516**, **520**, and/or zone **512**, associated with a vehicle **104**, may comprise one or more sensors to determine a presence of a user **216** and/or device **212**, **248** in and/or adjacent to each area **508**, **456**, **516**, **520**, and/or zone **512**. The sensors may include vehicle sensors **242** and/or non-vehicle sensors **236** as described herein. It is anticipated that the sensors may be configured to communicate with a vehicle control system **204** and/or the diagnostic communications module **256**. Additionally or alternatively, the sensors may communicate with a device **212**, **248**. The communication of sensors with the vehicle **104** may initiate and/or terminate the control of device **212**, **248** features. For example, a vehicle operator may be located in a second outside area **520** associated with a vehicle **104**. As the operator approaches the first outside area **516**, associated with the vehicle **104**, the vehicle control system **204** may determine to control features associated with one or more device **212**, **248** and diagnostic communications module **256**.

[0336] Optionally, the location of the device **212**, **248** relative to the vehicle **104** may determine vehicle functionality and/or features to be provided and/or restricted to a user **216**. By way of example, a device **212**, **248** associated with a user **216** may be located at a second outside area **520** from the vehicle **104**. In this case, and based at least partially on the distance of the device **212**, **248** from the vehicle **104** (e.g., provided by detecting the device **212**, **248** at or beyond the second outside area **520**) the vehicle **104** may lock one or more features (e.g., ignition access, vehicle access, communications ability, etc.) associated with the vehicle **104**. Optionally, the vehicle **104** may provide an alert based on the distance of the device **212**, **248** from the vehicle **104**. Continuing the example above, once the device **212**, **248** reaches

the first outside area 516 of the vehicle 104 at least one of the vehicle features may be unlocked. For instance, by reaching the first outside area 516, the vehicle 104 may unlock a door of the vehicle 104. In some cases, when the device is detected to be inside the vehicle 104, the various sensors 236, 242 may determine that the user 216 is in an area 508 and/or zone 512. As is further described herein, features of the vehicle 104, device 212, 248, and/or other components may be controlled based on rules stored in a memory.

[0337] FIG. 5B illustrates optional internal vehicle communications between one or more of the vehicle and one or more devices or between devices. Various communications can occur utilizing one or more Bluetooth®, NFC, WiFi, mobile hot spot, point-to-point communications, point-to-multipoint other point communications, an ad hoc network, or in general any known communications protocol over any known communications media or media-types.

[0338] Optionally, various types of internal vehicle communications can be facilitated using an access point 456 that utilizes one or more of Bluetooth®, NFC, WiFi, wireless Ethernet, mobile hot spot technology, or the like. Upon being connected with, and optionally authenticated to the access point 456, the connected device is able to communicate with one or more of the vehicle and one or more other devices that are connected to the access point 456. The type of connection to the access point 456 can be based on, for example, the zone 512, in which the device is located.

[0339] The user may identify their zone 512 in conjunction with an authentication procedure to the access point 456. For example, a driver in zone A 512A, upon authenticating to the access point 456, can cause the access point 456 to send a query to the device asking the device user in which zone 512 they are located. As discussed hereinafter, the zone 512 the user device is located in may have an impact on the type of communications, available bandwidth, the types of other devices or vehicle systems or subsystems the device could communicate with, and the like. As a brief introduction, internal communications with zone A 512A may be given preferential treatment over those communications originating from area 2 508B, which could have in itself, preferential treatment over communications originating within area N 508N.

[0340] Moreover, the device in zone A 512A can include profile information that governs the other devices that are allowed to connect to the access point 456 and what those devices have access to, how they can communicate, how much bandwidth they are allocated, and the like. While, optionally, the device associated with zone A 512A will be considered the “master” controller of the profile that governs the internal vehicle communications, it should be appreciated that this was arbitrarily chosen since it is assumed that there will always be a driver in a car that is present in zone A 512A. However, it should be appreciated the driver in zone A 512A, for example, may not have a communications device in which case a device associated with one of the other areas or zones, such as zone B 512B, area 2 508B, or area N 508N could also be associated with or control this master profile.

[0341] Optionally, various devices located within the various zones 512 can connect using, for example, ports provided by access point 456 or Bluetooth® access point/USB hub 460 as illustrated in FIG. 4. Similarly, the device(s) could connect utilizing the Femtocell 464 and optionally be directly connected via, for example, a standard Ethernet port.

[0342] As discussed, each one of the areas, area 1 508A, area 2 508B, and area N 508N, can each have associated

therewith a profile that governs, for example, how many and what types of devices can connect from that area 508, bandwidth allocated to that area 508, the types of media or content available to device(s) within that area 508, the interconnection of devices within that area 508 or between areas 508, or, in general, can control any aspect of communication of an associated device with any one or more other associated devices/vehicle systems within the vehicle 104.

[0343] Optionally, area 2 508B devices can be provided with full access to multimedia and infotainment available within the vehicle 104, however, devices in area 2 508B may be restricted from any access to vehicle functions. Only devices in area 1 508A may be able to access vehicle control functions such as when “parents” are located in area 1 508A and the children are located in area 2 508B. Optionally, devices found in zone E 512E of area 2 508B may be able to access limited vehicle control functionality such as climate control within area 2. Similarly, devices in area N 508N may be able to control climate features within zone N 512N.

[0344] As will be appreciated, profiles can be established that allow management of communications within each of the areas 508, and further optionally within each of the zones 512. The profile can be granular in nature controlling not only what type of devices can connect within each zone 512, but how those devices can communicate with other devices and/or the vehicle and types of information that can be communicated.

[0345] To assist with identifying a location of a device within a zone 512, a number of different techniques can be utilized. One optional technique involves one or more of the vehicle sensors detecting the presence of an individual within one of the zones 512. Upon detection of an individual in a zone 512, communications subsystems 344 and the access point 456 can cooperate to not only associate the device within the zone 512 with the access point 456 but to also determine the location of the device within an area, and optionally within a zone 512. Once the device is established within a zone 512, a profile associated with the vehicle 104 can store information identifying that device and/or a person and optionally associating it with a particular zone 512 as a default. As discussed, there can be a master profile optionally associated with the device in zone A 512A, this master profile can govern communications with the communications subsystems 340 and where communications within vehicle 104 are to occur.

[0346] Some optional profiles are illustrated below where the Master Profile governs other device connectivity:

Area 1 508A	Area 2 508B	Area N 508N	Other
Master Profile:			
All Communications	Allow Access to Infotainment	No Access	Master Profile acts as Firewall and Router
Secondary Profile (e.g., device in Zone B 512B, Area 1 508A)			
All Vehicle Controls	Allow Area 2 Climate Control	Allow Access to Infotainment	Master Profile acts as Firewall and Router
All Communications	Allow Access to Infotainment	Allow Access to Infotainment	Master Profile acts as Firewall and Router
All Vehicle Controls	Allow Area 2 Climate Control	Allow Area 2 Climate Control	

-continued

Area 1 508A	Area 2 508B	Area N 508N	Other
Secondary Profile, Option 2			
All Communications	Allow Access to Infotainment, Internet	Allow Access to Infotainment	
All Vehicle Controls Except Driver-centric Controls	Allow Area 2 Climate Control	Allow Area 2 Climate Control	

[0347] Some optional profiles are illustrated below where the Area/Zone governs device connectivity:

Area 1 508A	Area 2 508B	Area N 508N	Other
Area 2 508B Profile:			
No Communications with Area 1 Devices	Allow Access to Infotainment, Allow Access to Other Area 2 or Zone N Devices, Internet		
No Vehicle Controls	Allow Area 2 Climate Control		
Area N 508N Profile:			
Communications with Area 1, Zone B Device	Allow Access to Infotainment, Allow Access to Other Area N or Zone N Devices		
No Vehicle Controls	Allow Area N Climate Control		
Area 2 508B Profile:			
Media Sharing with Area 1, Zone B and Vehicle	Allow Access to Infotainment, Allow Access to Other Area 2 or Zone N Devices, Internet and Femtocell		
No Vehicle Controls			

[0348] Optionally, a user's device, such as a SmartPhone, can store in, for example a profile, with which zone 512 the user's device is associated. Then, assuming the user sits in the same zone 512 and area 508 as previously, the user's device can re-establish the same communications protocols with the access point 456 as were previously established.

[0349] In addition or in the alternative, the areas 508 and zones 512 can have associated therewith restrictions as to which one or more other user's devices with which users' devices can connect. For example, a first user's device can connect with any other user device in area 2 508B or area N 508N, however is restricted from connecting with a user device in area 1 508A, zone A 512A. However, the first user device may be able to communicate with another user's device that is located in area 1 508A, zone B 512B. These communications can include any type of standard communications such as sharing content, exchanging messages, forwarding or sharing multimedia or infotainment, or in general can include any communications that would ordinarily be available between two devices and/or the vehicle and vehicle systems. As discussed, there may be restrictions on the type of communications that can be sent to the device in area 1 508A, zone A 512A. For example, the user's device in area 1 508A,

zone A 512A may be restricted from receiving one or more of text messages, multimedia, infotainment, or in general anything that can be envisioned as a potential distraction to the driver. Moreover, it should be appreciated that the communications between the various devices and the various zones 512 need not necessarily occur with the assistance of access point 456, but the communications could also occur directly between the device(s).

[0350] FIG. 5C outlines optional internal vehicle communications between one or more of the vehicle and one or more devices. More specifically, FIG. 5C illustrates an example of vehicle communications where the vehicle 104 is equipped with the necessary transceivers to provide a mobile hot spot functionality to any user device(s) therein, such as user devices 248A and 248N.

[0351] Optionally, and as discussed above, one or more user devices can connect to the access point 456. This access point 456 is equipped to handle communications routing to not only the communication network/buses 224 for intra-vehicle communications, but optionally can also communicate with, for example, the Internet or the cloud, in cooperation with transceiver 260. Optionally included is a firewall 484 that has the capability of not only blocking certain types of content, such as a malicious content, but can also operate to exclude certain type of communications from emanating from the vehicle 104 and transceiver 260. As will be appreciated, various profiles could be established in the firewall 484 that controls not only the type of communications that can be received at the vehicle 104, but the type of communications that can be sent from the vehicle 104.

[0352] The transceiver 260 can be any type of well-known wireless transceiver that communicates using a known communications protocol such as WiMax, 4G, 4G LTE, 3G, or the like. The user devices can communicate via, for example, WiFi link 248 with the access point 456, with the transceiver 260 providing Internet connectivity to the various user devices. As will be appreciated, there may need to be an account associated with transceiver 260 with a wireless carrier to provide data and/or voice connectivity to enable the user devices to communicate with the Internet. Typically, the account is established on a month-to-month basis with an associated fee but could also be performed based on the amount of data to be transmitted, received, or in any other manner.

[0353] Moreover, one or more of the user's devices and access point 456 can maintain profile information that governs how the user's devices are able to communicate with other devices, and optionally the Internet. Optionally, a profile can exist that only allows the user's devices to communicate with other user's devices and/or the vehicle, multimedia and/or the vehicle infotainment system, and may not be allowed access to the Internet via transceiver 260. The profile can stipulate that the user's device could connect to the Internet via transceiver 260 for a specified period of time and/or up to a certain amount of data usage. The user's device can have full access to the Internet via transceiver 260 with no limit on time or data usage which would reduce the data usage of the user's device since it is connected via WiFi to the access point 456, but however, would increase the data usage by transceiver 260, and therefore, shift the billing for that data usage to the transceiver 260 instead of the user's device. Still further, and as previously discussed, the various profiles may stipulate which user's device has priority for use of the bandwidth provided by the transceiver 260. For example, a user's

device located area **1 508A**, zone A **512A** may be given preferential routing treatment of data above that of a user's device in zone N **512N**. In this manner, for example, a driver would be given priority for Internet access above that of the passengers. This could become important, for example, when the driver is trying to obtain traffic or direction information or, for example, when the vehicle is performing a download to update various software features.

[0354] As will be appreciated, the optional firewall **484** can cooperate with the access point **456** and the various profiles that area **508** associated with the various devices within the vehicle **104** and can fully implement communications restrictions, control bandwidth limits, Internet accessibility, malicious software blocking, and the like. Moreover, the optional firewall **484** can be accessed by an administrator with one or more of these configuration settings edited through an administrator's control panel. For example, in a scenario where parents are always in area **1 508A**, it may be appropriate to give all of the user's devices in area **1 508A** full access to the Internet utilizing transceiver **260**, however, while restricting access and/or bandwidth to any other user devices within the vehicle **104**. As the user's device and profile would be known by the firewall **484**, upon the user's device being associated with the access point **456**, the firewall **484** and transceiver **260** can be configured to allow communications in accordance with the stored profile.

[0355] A set of sensors or vehicle components **600** associated with the vehicle **104** may be as shown in FIG. 6A. The vehicle **104** can include, among many other components common to vehicles, wheels **607**, a power source **609** (such as an engine, motor, or energy storage system (e.g., battery or capacitive energy storage system)), a manual or automatic transmission **612**, a manual or automatic transmission gear controller **616**, a power controller **620** (such as a throttle), a vehicle control system **204**, the display device **212**, a braking system **636**, a steering wheel **640**, a power source activation/deactivation switch **644** (e.g., an ignition), an occupant seating system **648**, a wireless signal receiver **653** to receive wireless signals from signal sources such as roadside beacons and other electronic roadside devices, and a satellite positioning system receiver **657** (e.g., a Global Positioning System ("GPS") (US), GLONASS (Russia), Galileo positioning system (EU), Compass navigation system (China), and Regional Navigational Satellite System (India) receiver), driverless systems (e.g., cruise control systems, automatic steering systems, automatic braking systems, etc.).

[0356] The vehicle **104** can include a number of sensors in wireless or wired communication with the vehicle control system **204** and/or display device **212**, **248** to collect sensed information regarding the vehicle state, configuration, and/or operation. Exemplary sensors may include one or more of, but are not limited to, wheel state sensor **660** to sense one or more of vehicle speed, acceleration, deceleration, wheel rotation, wheel speed (e.g., wheel revolutions-per-minute), wheel slip, and the like, a power source energy output sensor **664** to sense a power output of the power source **609** by measuring one or more of current engine speed (e.g., revolutions-per-minute), energy input and/or output (e.g., voltage, current, fuel consumption, and torque) (e.g., turbine speed sensor, input speed sensor, crankshaft position sensor, manifold absolute pressure sensor, mass flow sensor, and the like), and the like, a switch state sensor **668** to determine a current activation or deactivation state of the power source activation/deactivation switch **644**, a transmission setting sensor **670** to

determine a current setting of the transmission (e.g., gear selection or setting), a gear controller sensor **672** to determine a current setting of the gear controller **616**, a power controller sensor **674** to determine a current setting of the power controller **620**, a brake sensor **676** to determine a current state (braking or non-braking) of the braking system **636**, a seating system sensor **678** to determine a seat setting and current weight of seated occupant, if any) in a selected seat of the seating system **648**, exterior and interior sound receivers **690** and **692** (e.g., a microphone, sonar, and other type of acoustic-to-electric transducer or sensor) to receive and convert sound waves into an equivalent analog or digital signal. Examples of other sensors (not shown) that may be employed include safety system state sensors to determine a current state of a vehicular safety system (e.g., air bag setting (deployed or undeployed) and/or seat belt setting (engaged or not engaged)), light setting sensor (e.g., current headlight, emergency light, brake light, parking light, fog light, interior or passenger compartment light, and/or tail light state (on or off)), brake control (e.g., pedal) setting sensor, accelerator pedal setting or angle sensor, clutch pedal setting sensor, emergency brake pedal setting sensor, door setting (e.g., open, closed, locked or unlocked) sensor, engine temperature sensor, passenger compartment or cabin temperature sensor, window setting (open or closed) sensor, one or more interior-facing or exterior-facing cameras or other imaging sensors (which commonly convert an optical image into an electronic signal but may include other devices for detection objects such as an electromagnetic radiation emitter/receiver that emits electromagnetic radiation and receives electromagnetic waves reflected by the object) to sense objects, such as other vehicles and pedestrians and optionally determine the distance, trajectory and speed of such objects, in the vicinity or path of the vehicle, odometer reading sensor, trip mileage reading sensor, wind speed sensor, radar transmitter/receiver output, brake wear sensor, steering/torque sensor, oxygen sensor, ambient lighting sensor, vision system sensor, ranging sensor, parking sensor, heating, venting, and air conditioning (HVAC) sensor, water sensor, air-fuel ratio meter, blind spot monitor, hall effect sensor, microphone, radio frequency (RF) sensor, infrared (IR) sensor, vehicle control system sensors, wireless network sensor (e.g., Wi-Fi and/or Bluetooth® sensor), cellular data sensor, and other sensors either future-developed or known to those of skill in the vehicle art.

[0357] In the depicted vehicle embodiment, the various sensors can be in communication with the display device **212**, **248** and vehicle control system **204** via signal carrier network **224**. As noted, the signal carrier network **224** can be a network of signal conductors, a wireless network (e.g., a radio frequency, microwave, or infrared communication system using a communications protocol, such as Wi-Fi), or a combination thereof. The vehicle control system **204** may also provide signal processing of one or more sensors, sensor fusion of similar and/or dissimilar sensors, signal smoothing in the case of erroneous "wild point" signals, and/or sensor fault detection. For example, ranging measurements provided by one or more RF sensors may be combined with ranging measurements from one or more IR sensors to determine one fused estimate of vehicle range to an obstacle target.

[0358] The control system **204** may receive and read sensor signals, such as wheel and engine speed signals, as a digital input comprising, for example, a pulse width modulated (PWM) signal. The processor **304** can be configured, for example, to read each of the signals into a port configured as

a counter or configured to generate an interrupt on receipt of a pulse, such that the processor **304** can determine, for example, the engine speed in revolutions per minute (RPM) and the speed of the vehicle in miles per hour (MPH) and/or kilometers per hour (KPH). One skilled in the art will recognize that the two signals can be received from existing sensors in a vehicle comprising a tachometer and a speedometer, respectively. Alternatively, the current engine speed and vehicle speed can be received in a communication packet as numeric values from a conventional dashboard subsystem comprising a tachometer and a speedometer. The transmission speed sensor signal can be similarly received as a digital input comprising a signal coupled to a counter or interrupt signal of the processor **304** or received as a value in a communication packet on a network or port interface from an existing subsystem of the vehicle **104**. The ignition sensor signal can be configured as a digital input, wherein a HIGH value represents that the ignition is on and a LOW value represents that the ignition is OFF. Three bits of the port interface can be configured as a digital input to receive the gear shift position signal, representing eight possible gear shift positions. Alternatively, the gear shift position signal can be received in a communication packet as a numeric value on the port interface. The throttle position signal can be received as an analog input value, typically in the range 0-5 volts. Alternatively, the throttle position signal can be received in a communication packet as a numeric value on the port interface. The output of other sensors can be processed in a similar fashion.

[0359] Other sensors may be included and positioned in the interior space **108** of the vehicle **104**. Generally, these interior sensors obtain data about the health of the driver and/or passenger(s), data about the safety of the driver and/or passenger(s), and/or data about the comfort of the driver and/or passenger(s). The health data sensors can include sensors in the steering wheel that can measure various health telemetry for the person (e.g., heart rate, temperature, blood pressure, blood presence, blood composition, etc.). Sensors in the seats may also provide for health telemetry (e.g., presence of liquid, weight, weight shifts, etc.). Infrared sensors could detect a person's temperature; optical sensors can determine a person's position and whether the person has become unconscious. Other health sensors are possible and included herein.

[0360] Safety sensors can measure whether the person is acting safely. Optical sensors can determine a person's position and focus. If the person stops looking at the road ahead, the optical sensor can detect the lack of focus. Sensors in the seats may detect if a person is leaning forward or may be injured by a seat belt in a collision. Other sensors can detect that the driver has at least one hand on a steering wheel. Other safety sensors are possible and contemplated as if included herein.

[0361] Comfort sensors can collect information about a person's comfort. Temperature sensors may detect a temperature of the interior cabin. Moisture sensors can determine a relative humidity. Audio sensors can detect loud sounds or other distractions. Audio sensors may also receive input from a person through voice data. Other comfort sensors are possible and contemplated as if included herein.

[0362] FIG. **6B** shows an interior sensor configuration for one or more zones **512** of a vehicle **104** optionally. Optionally, the areas **508** and/or zones **512** of a vehicle **104** may include sensors that are configured to collect information associated with the interior **108** of a vehicle **104**. In particular, the vari-

ous sensors may collect environmental information, user information, and safety information, to name a few. Embodiments of these sensors may be as described in conjunction with FIGS. **7A-8B**.

[0363] Optionally, the sensors may include one or more of optical, or image, sensors **622A-B** (e.g., cameras, etc.), motion sensors **624A-B** (e.g., utilizing RF, IR, and/or other sound/image sensing, etc.), steering wheel user sensors **642** (e.g., heart rate, temperature, blood pressure, sweat, health, etc.), seat sensors **677** (e.g., weight, load cell, moisture, electrical, force transducer, etc.), safety restraint sensors **679** (e.g., seatbelt, airbag, load cell, force transducer, etc.), interior sound receivers **692A-B**, environmental sensors **694** (e.g., temperature, humidity, air, oxygen, etc.), and the like.

[0364] The image sensors **622A-B** may be used alone or in combination to identify objects, users **216**, and/or other features, inside the vehicle **104**. Optionally, a first image sensor **622A** may be located in a different position within a vehicle **104** from a second image sensor **622B**. When used in combination, the image sensors **622A-B** may combine captured images to form, among other things, stereo and/or three-dimensional (3D) images. The stereo images can be recorded and/or used to determine depth associated with objects and/or users **216** in a vehicle **104**. Optionally, the image sensors **622A-B** used in combination may determine the complex geometry associated with identifying characteristics of a user **216**. For instance, the image sensors **622A-B** may be used to determine dimensions between various features of a user's face (e.g., the depth/distance from a user's nose to a user's cheeks, a linear distance between the center of a user's eyes, and more). These dimensions may be used to verify, record, and even modify characteristics that serve to identify a user **216**. As can be appreciated, utilizing stereo images can allow for a user **216** to provide complex gestures in a 3D space of the vehicle **104**. These gestures may be interpreted via one or more of the subsystems as disclosed herein. Optionally, the image sensors **622A-B** may be used to determine movement associated with objects and/or users **216** within the vehicle **104**. It should be appreciated that the number of image sensors used in a vehicle **104** may be increased to provide greater dimensional accuracy and/or views of a detected image in the vehicle **104**.

[0365] The vehicle **104** may include one or more motion sensors **624A-B**. These motion sensors **624A-B** may detect motion and/or movement of objects inside the vehicle **104**. Optionally, the motion sensors **624A-B** may be used alone or in combination to detect movement. For example, a user **216** may be operating a vehicle **104** (e.g., while driving, etc.) when a passenger in the rear of the vehicle **104** unbuckles a safety belt and proceeds to move about the vehicle **104**. In this example, the movement of the passenger could be detected by the motion sensors **624A-B**. Optionally, the user **216** could be alerted of this movement by one or more of the devices **212**, **248** in the vehicle **104**. In another example, a passenger may attempt to reach for one of the vehicle control features (e.g., the steering wheel **640**, the console, icons displayed on the head unit and/or device **212**, **248**, etc.). In this case, the movement (i.e., reaching) of the passenger may be detected by the motion sensors **624A-B**. Optionally, the path, trajectory, anticipated path, and/or some other direction of movement/motion may be determined using the motion sensors **624A-B**. In response to detecting the movement and/or the direction associated with the movement, the passenger may be prevented from interfacing with and/or accessing at least

some of the vehicle control features (e.g., the features represented by icons may be hidden from a user interface, the features may be locked from use by the passenger, combinations thereof, etc.). As can be appreciated, the user 216 may be alerted of the movement/motion such that the user 216 can act to prevent the passenger from interfering with the vehicle 104 controls. Optionally, the number of motion sensors in a vehicle 104, or areas of a vehicle 104, may be increased to increase an accuracy associated with motion detected in the vehicle 104.

[0366] The interior sound receivers 692A-B may include, but are not limited to, microphones and other types of acoustic-to-electric transducers or sensors. Optionally, the interior sound receivers 692A-B may be configured to receive and convert sound waves into an equivalent analog or digital signal. The interior sound receivers 692A-B may serve to determine one or more locations associated with various sounds in the vehicle 104. The location of the sounds may be determined based on a comparison of volume levels, intensity, and the like, between sounds detected by two or more interior sound receivers 692A-B. For instance, a first interior sound receiver 692A may be located in a first area of the vehicle 104 and a second interior sound receiver 692B may be located in a second area of the vehicle 104. If a sound is detected at a first volume level by the first interior sound receiver 692A and a second, higher, volume level by the second interior sound receiver 692B in the second area of the vehicle 104, the sound may be determined to be closer to the second area of the vehicle 104. As can be appreciated, the number of sound receivers used in a vehicle 104 may be increased (e.g., more than two, etc.) to increase measurement accuracy surrounding sound detection and location, or source, of the sound (e.g., via triangulation, etc.).

[0367] Seat sensors 677 may be included in the vehicle 104. The seat sensors 677 may be associated with each seat and/or zone 512 in the vehicle 104. Optionally, the seat sensors 677 may provide health telemetry and/or identification via one or more of load cells, force transducers, weight sensors, moisture detection sensor, electrical conductivity/resistance sensor, and the like. For example, the seat sensors 677 may determine that a user 216 weighs 180 lbs. This value may be compared to user data stored in memory to determine whether a match exists between the detected weight and a user 216 associated with the vehicle 104. In another example, if the seat sensors 677 detect that a user 216 is fidgeting, or moving, in a seemingly uncontrollable manner, the system may determine that the user 216 has suffered a nervous and/or muscular system issue (e.g., seizure, etc.). The vehicle control system 204 may then cause the vehicle 104 to slow down and in addition or alternatively the automobile controller 8104 (described below) can safely take control of the vehicle 104 and bring the vehicle 104 to a stop in a safe location (e.g., out of traffic, off a freeway, etc.).

[0368] Health telemetry and other data may be collected via the steering wheel user sensors 642. Optionally, the steering wheel user sensors 642 may collect heart rate, temperature, blood pressure, and the like, associated with a user 216 via at least one contact disposed on or about the steering wheel 640.

[0369] The safety restraint sensors 679 may be employed to determine a state associated with one or more safety restraint devices in a vehicle 104. The state associated with one or more safety restraint devices may serve to indicate a force observed at the safety restraint device, a state of activity (e.g., retracted, extended, various ranges of extension and/or retrac-

tion, deployment, buckled, unbuckled, etc.), damage to the safety restraint device, and more.

[0370] Environmental sensors 694, including one or more of temperature, humidity, air, oxygen, carbon monoxide, smoke, and other environmental condition sensors may be used in a vehicle 104. These environmental sensors 694 may be used to collect data relating to the safety, comfort, and/or condition of the interior space 108 of the vehicle 104. Among other things, the data collected by the environmental sensors 694 may be used by the vehicle control system 204 to alter functions of a vehicle. The environment may correspond to an interior space 108 of a vehicle 104 and/or specific areas 508 and/or zones 512 of the vehicle 104. It should be appreciated that an environment may correspond to a user 216. For example, a low oxygen environment may be detected by the environmental sensors 694 and associated with a user 216 who is operating the vehicle 104 in a particular zone 512. In response to detecting the low oxygen environment, at least one of the subsystems of the vehicle 104, as provided herein, may alter the environment, especially in the particular zone 512, to increase the amount of oxygen in the zone 512. Additionally or alternatively, the environmental sensors 694 may be used to report conditions associated with a vehicle (e.g., fire detected, low oxygen, low humidity, high carbon monoxide, etc.). The conditions may be reported to a user 216 and/or a third party via at least one communications module as provided herein.

[0371] Among other things, the sensors as disclosed herein may communicate with each other, with devices 212, 248, and/or with the vehicle control system 204 via the signal carrier network 224. Additionally or alternatively, the sensors disclosed herein may serve to provide data relevant to more than one category of sensor information including, but not limited to, combinations of environmental information, user information, and safety information to name a few.

[0372] FIGS. 7A-7B show block diagrams of various sensors that may be associated with a vehicle 104. Although depicted as interior and exterior sensors, it should be appreciated that any of the one or more of the sensors shown may be used in both the interior space 108 and the exterior space of the vehicle 104. Moreover, sensors having the same symbol or name may include the same, or substantially the same, functionality as those sensors described elsewhere in the present disclosure. Further, although the various sensors are depicted in conjunction with specific groups (e.g., environmental 708, 708E, user interface 712, safety 716, 716E, etc.) the sensors should not be limited to the groups in which they appear. In other words, the sensors may be associated with other groups or combinations of groups and/or disassociated from one or more of the groups shown. The sensors as disclosed herein may communicate with each other, the devices 212, 248, and/or the vehicle control system 204 via one or more communications channel(s) 356.

[0373] FIG. 7A is a block diagram of an embodiment of interior sensors 340 for a vehicle 104 is provided. The interior sensors 340 may be arranged into one or more groups, based at least partially on the function of the interior sensors 340. The interior space 108 of a vehicle 104 may include an environmental group 708, a user interface group 712, and a safety group 716. Additionally or alternatively, there may be sensors associated with various devices inside the vehicle (e.g., devices 212, 248, smart phones, tablets, mobile computers, etc.)

[0374] The environmental group 708 may comprise sensors configured to collect data relating to the internal environment of a vehicle 104. It is anticipated that the environment of the vehicle 104 may be subdivided into areas 508 and zones 512 in an interior space 108 of a vehicle 104. In this case, each area 508 and/or zone 512 may include one or more of the environmental sensors. Examples of environmental sensors associated with the environmental group 708 may include, but are not limited to, oxygen/air sensors 724, temperature sensors 728, humidity sensors 732, light/photo sensors 736, and more. The oxygen/air sensors 724 may be configured to detect a quality of the air in the interior space 108 of the vehicle 104 (e.g., ratios and/or types of gasses comprising the air inside the vehicle 104, dangerous gas levels, safe gas levels, etc.). Temperature sensors 728 may be configured to detect temperature readings of one or more objects, users 216, and/or areas 508 of a vehicle 104. Humidity sensors 732 may detect an amount of water vapor present in the air inside the vehicle 104. The light/photo sensors 736 can detect an amount of light present in the vehicle 104. Further, the light/photo sensors 736 may be configured to detect various levels of light intensity associated with light in the vehicle 104.

[0375] The user interface group 712 may comprise sensors configured to collect data relating to one or more users 216 in a vehicle 104. As can be appreciated, the user interface group 712 may include sensors that are configured to collect data from users 216 in one or more areas 508 and zones 512 of the vehicle 104. For example, each area 508 and/or zone 512 of the vehicle 104 may include one or more of the sensors in the user interface group 712. Examples of user interface sensors associated with the user interface group 712 may include, but are not limited to, infrared sensors 740, motion sensors 744, weight sensors 748, wireless network sensors 752, biometric sensors 756, camera (or image) sensors 760, audio sensors 764, and more.

[0376] Infrared sensors 740 may be used to measure IR light irradiating from at least one surface, user 216, or other object in the vehicle 104. Among other things, the Infrared sensors 740 may be used to measure temperatures, form images (especially in low light conditions), identify users 216, and even detect motion in the vehicle 104.

[0377] The motion sensors 744 may be similar to the motion detectors 624A-B, as described in conjunction with FIG. 6B. Weight sensors 748 may be employed to collect data relating to objects and/or users 216 in various areas 508 of the vehicle 104. In some cases, the weight sensors 748 may be included in the seats and/or floor of a vehicle 104.

[0378] Optionally, the vehicle 104 may include a wireless network sensor 752. This sensor 752 may be configured to detect one or more wireless network(s) inside the vehicle 104. Examples of wireless networks may include, but are not limited to, wireless communications utilizing Bluetooth®, Wi-Fi™, ZigBee, IEEE 802.11, and other wireless technology standards. For example, a mobile hotspot may be detected inside the vehicle 104 via the wireless network sensor 752. In this case, the vehicle 104 may determine to utilize and/or share the mobile hotspot detected via/with one or more other devices 212, 248 and/or components associated with the vehicle 104.

[0379] Biometric sensors 756 may be employed to identify and/or record characteristics associated with a user 216. It is anticipated that biometric sensors 756 can include at least one of image sensors, IR sensors, fingerprint readers, weight sen-

sors, load cells, force transducers, heart rate monitors, blood pressure monitors, and the like as provided herein.

[0380] The camera sensors 760 may be similar to image sensors 622A-B, as described in conjunction with FIG. 6B. Optionally, the camera sensors may record still images, video, and/or combinations thereof. The audio sensors 764 may be similar to the interior sound receivers 692A-B, as described in conjunction with FIGS. 6A-6B. The audio sensors may be configured to receive audio input from a user 216 of the vehicle 104. The audio input from a user 216 may correspond to voice commands, conversations detected in the vehicle 104, phone calls made in the vehicle 104, and/or other audible expressions made in the vehicle 104.

[0381] The safety group 716 may comprise sensors configured to collect data relating to the safety of a user 216 and/or one or more components of a vehicle 104. The vehicle 104 may be subdivided into areas 508 and/or zones 512 in an interior space 108 of a vehicle 104 where each area 508 and/or zone 512 may include one or more of the safety sensors provided herein. Examples of safety sensors associated with the safety group 716 may include, but are not limited to, force sensors 768, mechanical motion sensors 772, orientation sensors 776, restraint sensors 780, and more.

[0382] The force sensors 768 may include one or more sensors inside the vehicle 104 configured to detect a force observed in the vehicle 104. One example of a force sensor 768 may include a force transducer that converts measured forces (e.g., force, weight, pressure, etc.) into output signals.

[0383] Mechanical motion sensors 772 may correspond to encoders, accelerometers, damped masses, and the like. Optionally, the mechanical motion sensors 772 may be adapted to measure the force of gravity (i.e., G-force) as observed inside the vehicle 104. Measuring the G-force observed inside a vehicle 104 can provide valuable information related to a vehicle's acceleration, deceleration, collisions, and/or forces that may have been suffered by one or more users 216 in the vehicle 104. As can be appreciated, the mechanical motion sensors 772 can be located in an interior space 108 or an exterior of the vehicle 104.

[0384] Orientation sensors 776 can include accelerometers, gyroscopes, magnetic sensors, and the like that are configured to detect an orientation associated with the vehicle 104. Similar to the mechanical motion sensors 772, the orientation sensors 776 can be located in an interior space 108 or an exterior of the vehicle 104.

[0385] The restraint sensors 780 may be similar to the safety restraint sensors 679 as described in conjunction with FIGS. 6A-6B. These sensors 780 may correspond to sensors associated with one or more restraint devices and/or systems in a vehicle 104. Seatbelts and airbags are examples of restraint devices and/or systems. As can be appreciated, the restraint devices and/or systems may be associated with one or more sensors that are configured to detect a state of the device/system. The state may include extension, engagement, retraction, disengagement, deployment, and/or other electrical or mechanical conditions associated with the device/system.

[0386] The associated device sensors 720 can include any sensors that are associated with a device 212, 248 in the vehicle 104. As previously stated, typical devices 212, 248 may include smart phones, tablets, laptops, mobile computers, and the like. It is anticipated that the various sensors associated with these devices 212, 248 can be employed by the vehicle control system 204. For example, a typical smart

phone can include, an image sensor, an IR sensor, audio sensor, gyroscope, accelerometer, wireless network sensor, fingerprint reader, and more. It is an aspect of the present disclosure that one or more of these associated device sensors **720** may be used by one or more subsystems of the vehicle system **200**.

[0387] In FIG. 7B, a block diagram of an embodiment of exterior sensors **340** for a vehicle **104** is shown. The exterior sensors may include sensors that are identical, or substantially similar, to those previously disclosed in conjunction with the interior sensors of FIG. 7A. Optionally, the exterior sensors **340** may be configured to collect data relating to one or more conditions, objects, users **216**, and other events that are external to the interior space **108** of the vehicle **104**. For instance, the oxygen/air sensors **724** may measure a quality and/or composition of the air outside of a vehicle **104**. As another example, the motion sensors **744** may detect motion outside of a vehicle **104**.

[0388] The external environmental group **708E** may comprise sensors configured to collect data relating to the external environment of a vehicle **104**. In addition to including one or more of the sensors previously described, the external environmental group **708E** may include additional sensors, such as, vehicle sensors **750**, biological sensors, and wireless signal sensors **758**. Vehicle sensors **750** can detect vehicles that are in an environment surrounding the vehicle **104**. For example, the vehicle sensors **750** may detect vehicles in a first outside area **516**, a second outside area **520**, and/or combinations of the first and second outside areas **516**, **520**. Optionally, the vehicle sensors **750** may include one or more of RF sensors, IR sensors, image sensors, and the like to detect vehicles, people, hazards, etc. that are in an environment exterior to the vehicle **104**. Additionally or alternatively, the vehicle sensors **750** can provide distance/directional information relating to a distance (e.g., distance from the vehicle **104** to the detected object) and/or a direction (e.g., direction of travel, etc.) associated with the detected object.

[0389] The biological sensors **754** may determine whether one or more biological entities (e.g., an animal, a person, a user **216**, etc.) is in an external environment of the vehicle **104**. Additionally or alternatively, the biological sensors **754** may provide distance information relating to a distance of the biological entity from the vehicle **104**. Biological sensors **754** may include at least one of RF sensors, IR sensors, image sensors and the like that are configured to detect biological entities. For example, an IR sensor may be used to determine that an object, or biological entity, has a specific temperature, temperature pattern, or heat signature. Continuing this example, a comparison of the determined heat signature may be compared to known heat signatures associated with recognized biological entities (e.g., based on shape, locations of temperature, and combinations thereof, etc.) to determine whether the heat signature is associated with a biological entity or an inanimate, or non-biological, object.

[0390] The wireless signal sensors **758** may include one or more sensors configured to receive wireless signals from signal sources such as Wi-Fi™ hotspots, cell towers, roadside beacons, other electronic roadside devices, and satellite positioning systems. Optionally, the wireless signal sensors **758** may detect wireless signals from one or more of a mobile phone, mobile computer, keyless entry device, RFID device, near field communications (NFC) device, and the like.

[0391] The external safety group **716E** may comprise sensors configured to collect data relating to the safety of a user

216 and/or one or more components of a vehicle **104**. Examples of safety sensors associated with the external safety group **716E** may include, but are not limited to, force sensors **768**, mechanical motion sensors **772**, orientation sensors **776**, vehicle body sensors **782**, and more. Optionally, the exterior safety sensors **716E** may be configured to collect data relating to one or more conditions, objects, vehicle components, and other events that are external to the vehicle **104**. For instance, the force sensors **768** in the external safety group **716E** may detect and/or record force information associated with the outside of a vehicle **104**. For instance, if an object strikes the exterior of the vehicle **104**, the force sensors **768** from the exterior safety group **716E** may determine a magnitude, location, and/or time associated with the strike.

[0392] The vehicle **104** may include a number of vehicle body sensors **782**. The vehicle body sensors **782** may be configured to measure characteristics associated with the body (e.g., body panels, components, chassis, windows, etc.) of a vehicle **104**. For example, two vehicle body sensors **782**, including a first body sensor and a second body sensor, may be located at some distance apart. Continuing this example, the first body sensor may be configured to send an electrical signal across the body of the vehicle **104** to the second body sensor, or vice versa. Upon receiving the electrical signal from the first body sensor, the second body sensor may record a detected current, voltage, resistance, and/or combinations thereof associated with the received electrical signal. Values (e.g., current, voltage, resistance, etc.) for the sent and received electrical signal may be stored in a memory. These values can be compared to determine whether subsequent electrical signals sent and received between vehicle body sensors **782** deviate from the stored values. When the subsequent signal values deviate from the stored values, the difference may serve to indicate damage and/or loss of a body component. Additionally or alternatively, the deviation may indicate a problem with the vehicle body sensors **782**. The vehicle body sensors **782** may communicate with each other, a vehicle control system **204**, and/or systems of the vehicle system **200** via a communications channel **356**. Although described using electrical signals, it should be appreciated that alternative embodiments of the vehicle body sensors **782** may use sound waves and/or light to perform a similar function.

[0393] FIG. 8A is a block diagram of an embodiment of a media controller subsystem **348** for a vehicle **104**. The media controller subsystem **348** may include, but is not limited to, a media controller **804**, a media processor **808**, a match engine **812**, an audio processor **816**, a speech synthesis module **820**, a network transceiver **824**, a signal processing module **828**, memory **832**, and a language database **836**. Optionally, the media controller subsystem **348** may be configured as a dedicated blade that implements the media-related functionality of the system **200**. Additionally or alternatively, the media controller subsystem **348** can provide voice input, voice output, library functions for multimedia, and display control for various areas **508** and/or zones **512** of the vehicle **104**.

[0394] Optionally, the media controller subsystem **348** may include a local IP address (e.g., IPv4, IPv6, combinations thereof, etc.) and even a routable, global unicast address. The routable, global unicast address may allow for direct addressing of the media controller subsystem **348** for streaming data from Internet resources (e.g., cloud storage, user accounts, etc.). It is anticipated, that the media controller subsystem **348** can provide multimedia via at least one Internet connection,

or wireless network communications module, associated with the vehicle 104. Moreover, the media controller subsystem 348 may be configured to service multiple independent clients simultaneously.

[0395] The media processor 808 may comprise a general purpose programmable processor or controller for executing application programming or instructions related to the media subsystem 348. The media processor 808 may include multiple processor cores, and/or implement multiple virtual processors. Optionally, the media processor 808 may include multiple physical processors. By way of example, the media processor 808 may comprise a specially configured application specific integrated circuit (ASIC) or other integrated circuit, a digital signal processor, a controller, a hardwired electronic or logic circuit, a programmable logic device or gate array, a special purpose computer, or the like. The media processor 808 generally functions to run programming code or instructions implementing various functions of the media controller 804.

[0396] The match engine 812 can receive input from one or more components of the vehicle system 800 and perform matching functions. Optionally, the match engine 812 may receive audio input provided via a microphone 886 of the system 800. The audio input may be provided to the media controller subsystem 348 where the audio input can be decoded and matched, via the match engine 812, to one or more functions available to the vehicle 104. Similar matching operations may be performed by the match engine 812 relating to video input received via one or more image sensors, cameras 878, and the like.

[0397] The media controller subsystem 348 may include a speech synthesis module 820 configured to provide audio output to one or more speakers 880, or audio output devices, associated with the vehicle 104. Optionally, the speech synthesis module 820 may be configured to provide audio output based at least partially on the matching functions performed by the match engine 812.

[0398] As can be appreciated, the coding/decoding, the analysis of audio input/output, and/or other operations associated with the match engine 812 and speech synthesis module 820, may be performed by the media processor 808 and/or a dedicated audio processor 816. The audio processor 816 may comprise a general purpose programmable processor or controller for executing application programming or instructions related to audio processing. Further, the audio processor 816 may be similar to the media processor 808 described herein.

[0399] The network transceiver 824 can include any device configured to transmit and receive analog and/or digital signals. Optionally, the media controller subsystem 348 may utilize a network transceiver 824 in one or more communication networks associated with the vehicle 104 to receive and transmit signals via the communications channel 356. Additionally or alternatively, the network transceiver 824 may accept requests from one or more devices 212, 248 to access the media controller subsystem 348. One example of the communication network is a local-area network (LAN). As can be appreciated, the functionality associated with the network transceiver 824 may be built into at least one other component of the vehicle 104 (e.g., a network interface card, communications module, etc.).

[0400] The signal processing module 828 may be configured to alter audio/multimedia signals received from one or more input sources (e.g., microphones 886, etc.) via the com-

munications channel 356. Among other things, the signal processing module 828 may alter the signals received electrically, mathematically, combinations thereof, and the like.

[0401] The media controller 804 may also include memory 832 for use in connection with the execution of application programming or instructions by the media processor 808, and for the temporary or long term storage of program instructions and/or data. As examples, the memory 832 may comprise RAM, DRAM, SDRAM, or other solid state memory.

[0402] The language database 836 may include the data and/or libraries for one or more languages, as are used to provide the language functionality as provided herein. In one case, the language database 836 may be loaded on the media controller 804 at the point of manufacture. Optionally, the language database 836 can be modified, updated, and/or otherwise changed to alter the data stored therein. For instance, additional languages may be supported by adding the language data to the language database 836. In some cases, this addition of languages can be performed via accessing administrative functions on the media controller 804 and loading the new language modules via wired (e.g., USB, etc.) or wireless communication. In some cases, the administrative functions may be available via a vehicle console device 248, a user device 212, 248, and/or other mobile computing device that is authorized to access administrative functions (e.g., based at least partially on the device's address, identification, etc.).

[0403] One or more video controllers 840 may be provided for controlling the video operation of the devices 212, 248, 882 associated with the vehicle. Optionally, the video controller 840 may include a display controller for controlling the operation of touch sensitive screens, including input (touch sensing) and output (display) functions. Video data may include data received in a stream and unpacked by a processor and loaded into a display buffer. In this example, the processor and video controller 840 can optimize the display based on the characteristics of a screen of a display device 212, 248, 882. The functions of a touch screen controller may be incorporated into other components, such as a media processor 808 or display subsystem.

[0404] The audio controller 844 can provide control of the audio entertainment system (e.g., radio, subscription music service, multimedia entertainment, etc.), and other audio associated with the vehicle 104 (e.g., navigation systems, vehicle comfort systems, convenience systems, etc.). Optionally, the audio controller 844 may be configured to translate digital signals to analog signals and vice versa. As can be appreciated, the audio controller 844 may include device drivers that allow the audio controller 844 to communicate with other components of the system 800 (e.g., processors 816, 808, audio I/O 874, and the like).

[0405] The system 800 may include a profile identification module 848 to determine whether a user profile is associated with the vehicle 104. Among other things, the profile identification module 848 may receive requests from a user 216, or device 212, 228, 248, to access a profile stored in a profile database 856 or profile data 252. Additionally or alternatively, the profile identification module 848 may request profile information from a user 216 and/or a device 212, 228, 248, to access a profile stored in a profile database 856 or profile data 252. In any event, the profile identification module 848 may be configured to create, modify, retrieve, and/or store user profiles in the profile database 856 and/or profile data 252. The profile identification module 848 may include rules for

profile identification, profile information retrieval, creation, modification, and/or control of components in the system **800**.

[0406] By way of example, a user **216** may enter the vehicle **104** with a smart phone or other device **212**. In response to determining that a user **216** is inside the vehicle **104**, the profile identification module **848** may determine that a user profile is associated with the user's smart phone **212**. As another example, the system **800** may receive information about a user **216** (e.g., from a camera **878**, microphone **886**, etc.), and, in response to receiving the user information, the profile identification module **848** may refer to the profile database **856** to determine whether the user information matches a user profile stored in the database **856**. It is anticipated that the profile identification module **848** may communicate with the other components of the system to load one or more preferences, settings, and/or conditions based on the user profile. Further, the profile identification module **848** may be configured to control components of the system **800** based on user profile information.

[0407] Optionally, data storage **852** may be provided. Like the memory **832**, the data storage **852** may comprise a solid state memory device or devices. Alternatively or in addition, the data storage **852** may comprise a hard disk drive or other random access memory. Similar to the data storage **852**, the profile database **856** may comprise a solid state memory device or devices.

[0408] An input/output module **860** and associated ports may be included to support communications over wired networks or links, for example with other communication devices, server devices, and/or peripheral devices. Examples of an input/output module **860** include an Ethernet port, a Universal Serial Bus (USB) port, CAN Bus, Institute of Electrical and Electronics Engineers (IEEE) 1594, or other interface. Users may bring their own devices (e.g., Bring Your Own Device (BYOD), device **212**, etc.) into the vehicle **104** for use with the various systems disclosed. Although most BYOD devices can connect to the vehicle systems (e.g., the media controller subsystem **348**, etc.) via wireless communications protocols (e.g., Wi-Fi™, Bluetooth®, etc.) many devices may require a direct connection via USB, or similar. In any event, the input/output module **860** can provide the necessary connection of one or more devices to the vehicle systems described herein.

[0409] A video input/output interface **864** can be included to receive and transmit video signals between the various components in the system **800**. Optionally, the video input/output interface **864** can operate with compressed and uncompressed video signals. The video input/output interface **864** can support high data rates associated with image capture devices. Additionally or alternatively, the video input/output interface **864** may convert analog video signals to digital signals.

[0410] The infotainment system **870** may include information media content and/or entertainment content, informational devices, entertainment devices, and the associated programming therefor. Optionally, the infotainment system **870** may be configured to handle the control of one or more components of the system **800** including, but in no way limited to, radio, streaming audio/video devices, audio devices **880**, **882**, **886**, video devices **878**, **882**, travel devices (e.g., GPS, navigational systems, etc.), wireless communication devices, network devices, and the like. Further, the infotain-

ment system **870** can provide the functionality associated with other infotainment features as provided herein.

[0411] An audio input/output interface **874** can be included to provide analog audio to an interconnected speaker **880** or other device, and to receive analog audio input from a connected microphone **886** or other device. As an example, the audio input/output interface **874** may comprise an associated amplifier and analog to digital converter. Alternatively or in addition, the devices **212**, **248** can include integrated audio input/output devices **880**, **886** and/or an audio jack for interconnecting an external speaker **880** or microphone **886**. For example, an integrated speaker **880** and an integrated microphone **886** can be provided, to support near talk, voice commands, spoken information exchange, and/or speaker phone operations.

[0412] Among other things, the system **800** may include devices that are part of the vehicle **104** and/or part of a device **212**, **248** that is associated with the vehicle **104**. For instance, these devices may be configured to capture images, display images, capture sound, and present sound. Optionally, the system **800** may include at least one of image sensors/cameras **878**, display devices **882**, audio input devices/microphones **886**, and audio output devices/speakers **880**. The cameras **878** can be included for capturing still and/or video images. Alternatively or in addition, image sensors **878** can include a scanner or code reader. An image sensor/camera **878** can include or be associated with additional elements, such as a flash or other light source. In some cases, the display device **882** may include an audio input device and/or an audio output device in addition to providing video functions. For instance, the display device **882** may be a console, monitor, a tablet computing device, and/or some other mobile computing device.

[0413] FIG. 8B is a block diagram of an embodiment of a user/device interaction subsystem **817** in a vehicle system **800**. The user/device interaction subsystem **817** may comprise hardware and/or software that conduct various operations for or with the vehicle **104**. For instance, the user/device interaction subsystem **817** may include at least one user interaction subsystem **332** and device interaction subsystem **352** as previously described. These operations may include, but are not limited to, providing information to the user **216**, receiving input from the user **216**, and controlling the functions or operation of the vehicle **104**, etc. Among other things, the user/device interaction subsystem **817** may include a computing system operable to conduct the operations as described herein.

[0414] Optionally, the user/device interaction subsystem **817** can include one or more of the components and modules provided herein. For instance, the user/device interaction subsystem **817** can include one or more of a video input/output interface **864**, an audio input/output interface **874**, a sensor module **814**, a device interaction module **818**, a user identification module **822**, a vehicle control module **826**, an environmental control module **830**, and a gesture control module **834**. The user/device interaction subsystem **817** may be in communication with other devices, modules, and components of the system **800** via the communications channel **356**.

[0415] The user/device interaction subsystem **817** may be configured to receive input from a user **216** and/or device via one or more components of the system. By way of example, a user **216** may provide input to the user/device interaction subsystem **817** via wearable devices **802**, **806**, **810**, video input (e.g., via at least one image sensor/camera **878**, etc.)

audio input (e.g., via the microphone, audio input source, etc.), gestures (e.g., via at least one image sensor **878**, motion sensor **888**, etc.), device input (e.g., via a device **212**, **248** associated with the user, etc.), combinations thereof, and the like.

[**0416**] The wearable devices **802**, **806**, **810** can include heart rate monitors, blood pressure monitors, glucose monitors, pedometers, movement sensors, wearable computers, and the like. Examples of wearable computers may be worn by a user **216** and configured to measure user activity, determine energy spent based on the measured activity, track user sleep habits, determine user oxygen levels, monitor heart rate, provide alarm functions, and more. It is anticipated that the wearable devices **802**, **806**, **810** can communicate with the user/device interaction subsystem **817** via wireless communications channels or direct connection (e.g., where the device docks, or connects, with a USB port or similar interface of the vehicle **104**).

[**0417**] A sensor module **814** may be configured to receive and/or interpret input provided by one or more sensors in the vehicle **104**. In some cases, the sensors may be associated with one or more user devices (e.g., wearable devices **802**, **806**, **810**, smart phones **212**, mobile computing devices **212**, **248**, and the like). Optionally, the sensors may be associated with the vehicle **104**, as described in conjunction with FIGS. **6A-7B**.

[**0418**] The device interaction module **818** may communicate with the various devices as provided herein. Optionally, the device interaction module **818** can provide content, information, data, and/or media associated with the various subsystems of the vehicle system **800** to one or more devices **212**, **248**, **802**, **806**, **810**, **882**, etc. Additionally or alternatively, the device interaction module **818** may receive content, information, data, and/or media associated with the various devices provided herein.

[**0419**] The user identification module **822** may be configured to identify a user **216** associated with the vehicle **104**. The identification may be based on user profile information that is stored in profile data **252**. For instance, the user identification module **822** may receive characteristic information about a user **216** via a device, a camera, and/or some other input. The received characteristics may be compared to data stored in the profile data **252**. Where the characteristics match, the user **216** is identified. As can be appreciated, where the characteristics do not match a user profile, the user identification module **822** may communicate with other subsystems in the vehicle **104** to obtain and/or record profile information about the user **216**. This information may be stored in a memory and/or the profile data storage **252**.

[**0420**] The vehicle control module **826** may be configured to control settings, features, and/or the functionality of a vehicle **104**. In some cases, the vehicle control module **826** can communicate with the vehicle control system **204** to control critical functions (e.g., driving system controls, braking, accelerating, etc.) and/or noncritical functions (e.g., driving signals, indicator/hazard lights, mirror controls, window actuation, etc.) based at least partially on user/device input received by the user/device interaction subsystem **817**.

[**0421**] The environmental control module **830** may be configured to control settings, features, and/or other conditions associated with the environment, especially the interior environment, of a vehicle **104**. Optionally, the environmental control module **830** may communicate with the climate control system (e.g. changing cabin temperatures, fan speeds, air

direction, etc.), oxygen and/or air quality control system (e.g., increase/decrease oxygen in the environment, etc.), interior lighting (e.g., changing intensity of lighting, color of lighting, etc.), an occupant seating system **648** (e.g., adjusting seat position, firmness, height, etc.), steering wheel **640** (e.g., position adjustment, etc.), infotainment/entertainment system (e.g., adjust volume levels, display intensity adjustment, change content, etc.), and/or other systems associated with the vehicle environment. Additionally or alternatively, these systems can provide input, set-points, and/or responses, to the environmental control module **830**. As can be appreciated, the environmental control module **830** may control the environment based at least partially on user/device input received by the user/device interaction subsystem **817**.

[**0422**] The gesture control module **834** is configured to interpret gestures provided by a user **216** in the vehicle **104**. Optionally, the gesture control module **834** may provide control signals to one or more of the vehicle systems **300** disclosed herein. For example, a user **216** may provide gestures to control the environment, critical and/or noncritical vehicle functions, the infotainment system, communications, networking, and more. Optionally, gestures may be provided by a user **216** and detected via one or more of the sensors as described in conjunction with FIGS. **6B-7A**. As another example, one or more motion sensors **888** may receive gesture input from a user **216** and provide the gesture input to the gesture control module **834**. Continuing this example, the gesture input is interpreted by the gesture control module **834**. This interpretation may include comparing the gesture input to gestures stored in a memory. The gestures stored in memory may include one or more functions and/or controls mapped to specific gestures. When a match is determined between the detected gesture input and the stored gesture information, the gesture control module **834** can provide a control signal to any of the systems/subsystems as disclosed herein.

[**0423**] FIG. **8C** illustrates a GPS/Navigation subsystem(s) **336**. The Navigation subsystem(s) **336** can be any present or future-built navigation system that may use location data, for example, from the Global Positioning System (GPS), to provide navigation information or control the vehicle **104**. The Navigation subsystem(s) **336** can include several components or modules, such as, one or more of, but not limited to, a GPS Antenna/receiver **892**, a location module **896**, a maps database **8100**, an automobile controller **8104**, a vehicle systems transceiver **8108**, a traffic controller **8112**, a network traffic transceiver **8116**, a vehicle-to-vehicle transceiver **8120**, a traffic information database **8124**, etc. Generally, the several components or modules **892-8124** may be hardware, software, firmware, computer readable media, or combinations thereof.

[**0424**] A GPS Antenna/receiver **892** can be any antenna, GPS puck, and/or receiver capable of receiving signals from a GPS satellite or other navigation system, as mentioned hereinbefore. The signals may be demodulated, converted, interpreted, etc. by the GPS Antenna/receiver **892** and provided to the location module **896**. Thus, the GPS Antenna/receiver **892** may convert the time signals from the GPS system and provide a location (e.g., coordinates on a map) to the location module **896**. Alternatively, the location module **896** can interpret the time signals into coordinates or other location information.

[**0425**] The location module **896** can be the controller of the satellite navigation system designed for use in automobiles.

The location module **896** can acquire position data, as from the GPS Antenna/receiver **892**, to locate the user or vehicle **104** on a road in the unit's map database **8100**. Using the road database **8100**, the location module **896** can give directions to other locations along roads also in the database **8100**. When a GPS signal is not available, the location module **896** may apply dead reckoning to estimate distance data from sensors **242** including one or more of, but not limited to, a speed sensor attached to the drive train of the vehicle **104**, a gyroscope, an accelerometer, etc. GPS signal loss and/or multipath can occur due to urban canyons, tunnels, and other obstructions. Additionally or alternatively, the location module **896** may use known locations of Wi-Fi hotspots, cell tower data, etc. to determine the position of the vehicle **104**, such as by using time difference of arrival (TDOA) and/or frequency difference of arrival (FDOA) techniques.

[**0426**] The maps database **8100** can include any hardware and/or software to store information about maps, geographical information system information, location information, etc. The maps database **8100** can include any data definition or other structure to store the information. Generally, the maps database **8100** can include a road database that may include one or more vector maps of areas of interest. Street names, street numbers, house numbers, and other information can be encoded as geographic coordinates so that the user can find some desired destination by street address. Points of interest (waypoints) can also be stored with their geographic coordinates. For example, a point of interest may include speed cameras, fuel stations, public parking, and "parked here" (or "you parked here") information. The map database contents can be produced or updated by a server connected through a wireless system in communication with the Internet, even as the vehicle **104** is driven along existing streets, yielding an up-to-date map.

[**0427**] An automobile controller **8104** can be any hardware and/or software that can receive instructions from the location module **896** or the traffic controller **8112** and operate the vehicle **104**. The automobile controller **8104** receives this information and data from the sensors **242** to operate the vehicle **104** without driver input. Thus, the automobile controller **8104** can drive the vehicle **104** along a route provided by the location module **896**. The route may be adjusted by information sent from the traffic controller **8112**. Discrete and real-time driving can occur with data from the sensors **242**. To operate the vehicle **104**, the automobile controller **8104** can communicate with a vehicle systems transceiver **8108**.

[**0428**] The vehicle systems transceiver **8108** can be any present or future-developed device that can comprise a transmitter and/or a receiver, which may be combined and can share common circuitry or a single housing. The vehicle systems transceiver **8108** may communicate or instruct one or more of the vehicle control subsystems **328**. For example, the vehicle systems transceiver **8108** may send steering commands, as received from the automobile controller **8104**, to an electronic steering system, to adjust the steering of the vehicle **100** in real time. The automobile controller **8104** can determine the effect of the commands based on received sensor data **242** and can adjust the commands as need be. The vehicle systems transceiver **8108** can also communicate with the braking system, the engine and drive train to speed or slow the car, the signals (e.g., turn signals and brake lights), the headlights, the windshield wipers, etc. Any of these communications may occur over the components or function as described in conjunction with FIG. 4.

[**0429**] A traffic controller **8112** can be any hardware and/or software that can communicate with an automated traffic system and adjust the function of the vehicle **104** based on instructions from the automated traffic system. An automated traffic system is a system that manages the traffic in a given area. This automated traffic system can instruct cars to drive in certain lanes, instruct cars to raise or lower their speed, instruct a car to change their route of travel, instruct cars to communicate with other cars, etc. To perform these functions, the traffic controller **8112** may register the vehicle **104** with the automated traffic system and then provide other information including the route of travel. The automated traffic system can return registration information and any required instructions. The communications between the automated traffic system and the traffic controller **8112** may be received and sent through a network traffic transceiver **8116**.

[**0430**] The network traffic transceiver **8116** can be any present or future-developed device that can comprise a transmitter and/or a receiver, which may be combined and can share common circuitry or a single housing. The network traffic transceiver **8116** may communicate with the automated traffic system using any known or future-developed, protocol, standard, frequency, bandwidth range, etc. The network traffic transceiver **8116** enables the sending of information between the traffic controller **8112** and the automated traffic system.

[**0431**] The traffic controller **8112** can also communicate with another vehicle, which may be in physical proximity (i.e., within range of a wireless signal), using the vehicle-to-vehicle transceiver **8120**. As with the network traffic transceiver **8116**, the vehicle-to-vehicle transceiver **8120** can be any present or future-developed device that can comprise a transmitter and/or a receiver, which may be combined and can share common circuitry or a single housing. Generally, the vehicle-to-vehicle transceiver **8120** enables communication between the vehicle **104** and any other vehicle. These communications allow the vehicle **104** to receive traffic or safety information, control or be controlled by another vehicle, establish an alternative communication path to communicate with the automated traffic system, establish a node including two or more vehicle that can function as a unit, etc. The vehicle-to-vehicle transceiver **8120** may communicate with the other vehicles using any known or future-developed, protocol standard, frequency, bandwidth range, etc.

[**0432**] The traffic controller **8112** can control functions of the automobile controller **8104** and communicate with the location module **896**. The location module **896** can provide current location information and route information that the traffic controller **8112** may then provide to the automated traffic system. The traffic controller **8112** may receive route adjustments from the automated traffic system that are then sent to the location module **896** to change the route. Further, the traffic controller **8112** can also send driving instructions to the automobile controller **8104** to change the driving characteristics of the vehicle **104**. For example, the traffic controller **8112** can instruct the automobile controller **8104** to accelerate or decelerate to a different speed, change lanes, or perform another driving maneuver. The traffic controller **8112** can also manage vehicle-to-vehicle communications and store information about the communications or other information in the traffic information database **8124**.

[**0433**] The traffic information database **8124** can be any type of database, such as relational, hierarchical, object-oriented, and/or the like. The traffic information database **8124**

may reside on a storage medium local to (and/or resident in) the vehicle control system **204** or in the vehicle **104**. The traffic information database **8124** may be adapted to store, update, and retrieve information about communications with other vehicles or any active instructions from the automated traffic system. This information may be used by the traffic controller **8112** to instruct or adjust the performance of driving maneuvers.

[0434] FIG. 9 illustrates an optional communications architecture where, the host device **908** may include one more routing profiles, permission modules, and rules that control how communications within the vehicle **104** are to occur. This communications architecture can be used in conjunction with the routing tables, rules and permissions associated with access point **456** and optional firewall **484**, or can be in lieu thereof. For example, the host device **908** acts as a mobile hot spot to one or more other devices within vehicle **104**, such as, other device **1912**, other device **2916**, other device **3920**, and other device **N 924**. Optionally, one or more of the other devices **912** can communicate directly with the host device **908** which then provides Internet access to those devices **912** via the device **908**. The host device **908** can act as a mobile hot spot for any one or more of the other devices **912**, which may not need to communicate over the network/communications buses **224/404**, but could instead connect directly to the host device **908** via, for example, NFC, Bluetooth®, WiFi, or the like. When the device **908** is acting as the host device, the device **908** can include one or more routing profiles, permissions, rules modules, and can also act as a firewall for the various inter and intra vehicle communications.

[0435] As will be appreciated, there could be alternative host devices, such as, host **904** which could also act as, for example, a co-host in association with device **908**. Optionally, one or more of the routing profile, permission information, and rules could be shared between the co-host devices **904**, **908**, both of those devices being usable for Internet access for one or more of the other devices, **912-924**. As will be appreciated, the other devices **912-924** need not necessarily connect to one or more of host device **908** and the other device **904** via a direct communications link, but could also interface with those devices **904**, **908** utilizing the network/communications buses **224/404** associated with the vehicle **100**. As previously discussed, one or more of the other devices can connect to the network/communications buses **224/404** utilizing the various networks and/or buses discussed herein which would therefore enable, for example, regulation of the various communications based on the Ethernet zone that the other device **912** is associated with.

[0436] An embodiment of one or more modules that may be associated with the vehicle control system **204** may be as shown in FIG. 10. The modules can include a communication subsystem interface **1008** in communication with an operating system **1004**. The communications may pass through a firewall **1044**. The firewall **1044** can be any software that can control the incoming and outgoing communications by analyzing the data packets and determining whether the packets should be allowed through the firewall, based on applied rule set. A firewall **1044** can establish a “barrier” between a trusted, secure internal network and another network (e.g., the Internet) that is not assumed to be secure and trusted.

[0437] In some situations, the firewall **1044** may establish security zones that are implemented by running system services and/or applications in restricted user groups and accounts. A set of configuration files and callbacks may then

be linked to an IP table firewall. The IP table firewall can be configured to notify a custom filter application at any of the layers of the Ethernet packet. The different users/group rights to access the system may include: system users, which may have exclusive right over all device firewall rules and running software; a big-brother user, which may have access to on board device (OBD) control data and may be able to communicate with the vehicle subsystem **328** and may be able to alter the parameters in the vehicle control system **204**; a dealer user, which can have rights to read OBD data for diagnostics and repairs; a dashboard user, which can have rights to launch dashboard applications and/or authenticate guest users and change their permissions to trusted/friend/family, and can read but cannot write into OBD diagnostic data; a world wide web (WWW) data user, which can have HTTP rights to respond to HTTP requests (the HTTP requests also can target different user data, but may be filtered by default user accounts); a guest user, which may have no rights; a family/friend user, which may have rights to play media from the media subsystem **348** and/or to stream media to the media subsystem **348**.

[0438] The operating system **1004** can be a collection of software that manages computer hardware resources and provides common services for applications and other programs. The operating system **1004** may schedule time-sharing for efficient use of the system. For hardware functions, such as input, output, and memory allocation, the operating system **1004** can act as an intermediary between applications or programs and the computer hardware. Examples of operating systems that may be deployed as operating system **1004** include Android, BSD, iOS, Linux, OS X, QNX, Microsoft Windows, Windows Phone, IBM z/OS, etc.

[0439] The operating system **1004** can include one or more sub-modules. For example, a desktop manager **1012** can manage one or more graphical user interfaces (GUI) in a desktop environment. Desktop GUIs can help the user to easily access and edit files. A command-line interface (CLI) may be used if full control over the operating system (OS) **1004** is required. The desktop manager **1012** is described further hereinafter.

[0440] A kernel **1028** can be a computer program that manages input/output requests from software and translates them into data processing instructions for the processor **304** and other components of the vehicle control system **204**. The kernel **1028** is the fundamental component of the operating system **1004** that can execute many of the functions associated with the OS **1004**.

[0441] The kernel **1028** can include other software functions, including, but not limited to, driver(s) **1056**, communication software **1052**, and/or Internet Protocol software **1048**. A driver **1056** can be any computer program that operates or controls a particular type of device that is attached to a vehicle control system **204**. A driver **1056** can communicate with the device through the bus **356** or communications subsystem **1008** to which the hardware connects. When a calling program invokes a routine in the driver **1056**, the driver **1056** may issue one or more commands to the device. Once the device sends data back to the driver **1056**, the driver **1056** may invoke routines in the original calling program. Drivers can be hardware-dependent and operating-system-specific. Driver (s) **1056** can provide the interrupt handling required for any necessary asynchronous time-dependent hardware interface.

[0442] The IP module **1048** can conduct any IP addressing, which may include the assignment of IP addresses and associated parameters to host interfaces. The address space may

include networks and sub-networks. The IP module **1048** can perform the designation of network or routing prefixes and may conduct IP routing, which transports packets across network boundaries. Thus, the IP module **1048** may perform all functions required for IP multicast operations.

[0443] The communications module **1052** may conduct all functions for communicating over other systems or using other protocols not serviced by the IP module **1048**. Thus, the communications module **1052** can manage multicast operations over other busses or networks not serviced by the IP module **1048**. Further, the communications module **1052** may perform or manage communications to one or more devices, systems, data stores, services, etc. that are in communication with the vehicle control system **204** or other subsystems through the firewall **1044**. Thus, the communications module **1052** can conduct communications through the communication subsystem interface **1008**.

[0444] A file system **1016** may be any data handling software that can control how data is stored and retrieved. The file system **1016** can separate the stored data into individual pieces, and giving each piece a name, can easily separate and identify the pieces of data. Each piece of data may be considered a "file". The file system **1016** can construct data structure and logic rules used to manage the information and the identifiers for the information. The structure and logic rules can be considered a "file system."

[0445] A device discovery daemon **1020** may be a computer program that runs as a background process that can discover new devices that connect with the network **356** or communication subsystem **1008** or devices that disconnect from the network **356** or communication subsystem **1008**. The device discovery daemon **1020** can ping the network **356** (the local subnet) when the vehicle **104** starts, when a vehicle door opens or closes, or upon the occurrence of other events. Additionally or alternatively, the device discovery daemon **1020** may force Bluetooth®, USB, and/or wireless detection. For each device that responds to the ping, the device discovery daemon **1020** can populate the system data **208** with device information and capabilities, using any of one or more protocols, including one or more of, but not limited to, IPv6 Hop-by-Hop Option (HOPOPT), Internet Control Message Protocol (ICMP), Internet Group Management Protocol (IGMP), Gateway-to-Gateway Protocol (GGP), Internet Protocol (IP), Internet Stream Protocol (ST), Transmission Control Protocol (TCP), Exterior Gateway Protocol (EGP), CHAOS, User Datagram Protocol (UDP), etc.

[0446] For example, the device discovery daemon **1020** can determine device capabilities based on the opened ports the device exposes. If a camera exposes port **80**, then the device discovery daemon **1020** can determine that the camera is using a Hypertext Transfer Protocol (HTTP). Alternatively, if a device is supporting Universal Plug and Play (UPnP), the system data **208** can include more information, for example, a camera control universal resource locator (URL), a camera zoom URL, etc. When a scan stops, the device discovery daemon **1020** can trigger a dashboard refresh to ensure the user interface reflects the new devices on the desktop.

[0447] A desktop manager **1012** may be a computer program that manages the user interface of the vehicle control system **204**. The desktop environment may be designed to be customizable and allow the definition of the desktop configuration look-and-feel for a wide range of appliances or devices from computer desktops, mobile devices, computer tablets, etc. Launcher(s), panels, desktop areas, the desktop back-

ground, notifications, panes, etc., can be configured from a dashboard configuration file managed by the desktop manager **1012**. The graphical elements in which the desktop manager **1012** controls can include launchers, the desktop, notification bars, etc.

[0448] The desktop may be an area of the display where the applications are running. The desktop can have a custom background. Further, the desktop may be divided into two or more areas. For example, the desktop may be divided into an upper half of a display and a lower half of the display. Each application can be configured to run in a portion of the desktop. Extended settings can be added to the desktop configuration file, such that, some objects may be displayed over the whole desktop or in custom size out of the context of the divided areas.

[0449] The notification bar may be a part of a bar display system, which may provide notifications by displaying, for example, icons and/or pop-up windows that may be associated with sound notifications. The notification mechanism can be designed for separate plug-ins, which run in separate processes and may subscribe to a system Intelligent Input Bus (IBUS)/D-BUS event service. The icons on the notifications bar can be accompanied with application short-cuts to associated applications, for example, a Bluetooth® manager, a USB manager, radio volume and or tone control, a security firewall, etc.

[0450] The desktop manager **1012** may include a windows manager **1032**, an application launcher **1036**, and/or a panel launcher **1040**. Each of these components can control a different aspect of the user interface. The desktop manager **1012** can use a root window to create panels that can include functionality for one or more of, but not limited to: launching applications, managing applications, providing notifications, etc.

[0451] The windows manager **1032** may be software that controls the placement and appearance of windows within a graphical user interface presented to the user. Generally, the windows manager **1032** can provide the desktop environment used by the vehicle control system **204**. The windows manager **1032** can communicate with the kernel **1028** to interface with the graphical system that provides the user interface(s) and supports the graphics hardware, pointing devices, keyboard, touch-sensitive screens, etc. The windows manager **1032** may be a tiling window manager (i.e., a window manager with an organization of the screen into mutually non-overlapping frames, as opposed to a coordinate-based stacking of overlapping objects (windows) that attempts to fully emulate the desktop metaphor). The windows manager **1032** may read and store configuration files, in the system data **208**, which can control the position of the application windows at precise positions.

[0452] An application manager **1036** can control the function of any application over the lifetime of the process. The process or application can be launched from a panel launcher **1040** or from a remote console. The application manager **1036** can intercept the process name and may take appropriate action to manage that process. If the process is not running, the application manager **1036** can load the process and may bring the process to a foreground in a display. The application manager **1036** may also notify the windows manager **1032** to bring the associated window(s) to a top of a window stack for the display. When a process starts from a shell or a notification out of the context of the desktop, the application manager **1036** can scan files to match the process name with the entry

name provided. When a match is found, the application manager **1036** can configure the process according to a settings file.

[0453] In some situations, the application manager **1036** may restrict an application as singleton (i.e., restricts the instantiation of a class to one object). If an application is already running and the application manager **1036** is asked to run the application again, the application manager **1036** can bring the running process to a foreground on a display. There can be a notification event exchange between the windows manager **1032** and the application manager **1036** for activating the appropriate window for the foreground process. Once an application is launched, the application may not be terminated or killed. The application can be sent to the background, except, possibly, for some applications (e.g., media player, Bluetooth®, notifications, etc.), which may be given a lowest process priority.

[0454] The panel launcher **1040** can be a widget configured to be placed along a portion of the display. The panel launcher **1040** may be built from desktop files from a desktop folder. The desktop folder location can be configured by a configuration file stored in system data **208**. The panel launcher **1040** can allow for the launching or executing of applications or processes by receiving inputs from a user interface to launch programs.

[0455] A desktop plugin **1024** may be a software component that allows for customization of the desktop or software interface through the initiation of plug-in applications. One or more gestures used to interface with the vehicle control system **204** may be as described in conjunction with FIG. 11A through 11K. FIGS. 11A through 11H depict various graphical representations of gesture inputs that may be recognized by the devices **212**, **248**. The gestures may be performed not only by a user's body part, such as a digit, but also by other devices, such as a stylus, that may be sensed by the contact sensing portion(s) of a screen associated with the device **212**, **248**. In general, gestures are interpreted differently, based on where the gestures are performed (either directly on a display or in a gesture capture region). For example, gestures in a display may be directed to a desktop or application, and gestures in a gesture capture region may be interpreted as for the system.

[0456] With reference to FIGS. 11A-11H, a first type of gesture, a touch gesture **1120**, is substantially stationary on a portion (e.g., a screen, a display, etc.) of a device **212**, **248** for a selected length of time. A circle **1128** represents a touch or other contact type received at particular location of a contact sensing portion of the screen. The circle **1128** may include a border **1132**, the thickness of which indicates a length of time that the contact is held substantially stationary at the contact location. For instance, a tap **1120** (or short press) has a thinner border **1132A** than the border **1132B** for a long press **1124** (or for a normal press). The long press **1124** may involve a contact that remains substantially stationary on the screen for longer time period than that of a tap **1120**. As will be appreciated, differently defined gestures may be registered depending upon the length of time that the touch remains stationary prior to contact cessation or movement on the screen.

[0457] With reference to FIG. 11C, a drag gesture **1100** on the screen is an initial contact (represented by circle **1128**) with contact movement **1136** in a selected direction. The initial contact **1128** may remain stationary on the screen for a certain amount of time represented by the border **1132**. The drag gesture typically requires the user to contact an icon,

window, or other displayed image at a first location followed by movement of the contact in a drag direction to a new second location desired for the selected displayed image. The contact movement need not be in a straight line but have any path of movement so long as the contact is substantially continuous from the first to the second locations.

[0458] With reference to FIG. 11D, a flick gesture **1104** on the screen is an initial contact (represented by circle **1128**) with truncated contact movement **1136** (relative to a drag gesture) in a selected direction. A flick may have a higher exit velocity for the last movement in the gesture compared to the drag gesture. The flick gesture can, for instance, be a finger snap following initial contact. Compared to a drag gesture, a flick gesture generally does not require continual contact with the screen from the first location of a displayed image to a predetermined second location. The contacted displayed image is moved by the flick gesture in the direction of the flick gesture to the predetermined second location. Although both gestures commonly can move a displayed image from a first location to a second location, the temporal duration and distance of travel of the contact on the screen is generally less for a flick than for a drag gesture.

[0459] With reference to FIG. 11E, a pinch gesture **1108** on the screen is depicted. The pinch gesture **1108** may be initiated by a first contact **1128A** to the screen by, for example, a first digit and a second contact **1128B** to the screen by, for example, a second digit. The first and second contacts **1128A,B** may be detected by a common contact sensing portion of a common screen, by different contact sensing portions of a common screen, or by different contact sensing portions of different screens. The first contact **1128A** is held for a first amount of time, as represented by the border **1132A**, and the second contact **1128B** is held for a second amount of time, as represented by the border **1132B**. The first and second amounts of time are generally substantially the same, and the first and second contacts **1128A,B** generally occur substantially simultaneously. The first and second contacts **1128A,B** generally also include corresponding first and second contact movements **1136A,B**, respectively. The first and second contact movements **1136A,B** are generally in opposing directions. Stated another way, the first contact movement **1136A** is towards the second contact **1136B**, and the second contact movement **1136B** is towards the first contact **1136A**. More simply stated, the pinch gesture **1108** may be accomplished by a user's digits touching the screen in a pinching motion.

[0460] With reference to FIG. 11F, a spread gesture **1110** on the screen is depicted. The spread gesture **1110** may be initiated by a first contact **1128A** to the screen by, for example, a first digit, and a second contact **1128B** to the screen by, for example, a second digit. The first and second contacts **1128A,B** may be detected by a common contact sensing portion of a common screen, by different contact sensing portions of a common screen, or by different contact sensing portions of different screens. The first contact **1128A** is held for a first amount of time, as represented by the border **1132A**, and the second contact **1128B** is held for a second amount of time, as represented by the border **1132B**. The first and second amounts of time are generally substantially the same, and the first and second contacts **1128A,B** generally occur substantially simultaneously. The first and second contacts **1128A,B** generally also include corresponding first and second contact movements **1136A,B**, respectively. The first and second contact movements **1136A,B** are generally in an

opposing direction. Stated another way, the first and second contact movements **1136A,B** are away from the first and second contacts **1128A,B**. More simply stated, the spread gesture **1110** may be accomplished by a user's digits touching the screen in a spreading motion.

[0461] The above gestures may be combined in any manner, such as those shown by FIGS. **11G** and **11H**, to produce a determined functional result. For example, in FIG. **11G** a tap gesture **1120** is combined with a drag or flick gesture **1112** in a direction away from the tap gesture **1120**. In FIG. **11H**, a tap gesture **1120** is combined with a drag or flick gesture **1116** in a direction towards the tap gesture **1120**.

[0462] The functional result of receiving a gesture can vary depending on a number of factors, including a state of the vehicle **104**, display, or screen of a device, a context associated with the gesture, or sensed location of the gesture, etc. The state of the vehicle **104** commonly refers to one or more of a configuration of the vehicle **104**, a display orientation, and user and other inputs received by the vehicle **104**. Context commonly refers to one or more of the particular application (s) selected by the gesture and the portion(s) of the application currently executing, whether the application is a single- or multi-screen application, and whether the application is a multi-screen application displaying one or more windows. A sensed location of the gesture commonly refers to whether the sensed set(s) of gesture location coordinates are on a touch sensitive display or a gesture capture region of a device **212**, **248**, whether the sensed set(s) of gesture location coordinates are associated with a common or different display, or screen, or device **212**, **248**, and/or what portion of the gesture capture region contains the sensed set(s) of gesture location coordinates.

[0463] A tap, when received by a touch sensitive display of a device **212**, **248**, can be used, for instance, to select an icon to initiate or terminate execution of a corresponding application, to maximize or minimize a window, to reorder windows in a stack, and/or to provide user input such as by keyboard display or other displayed image. A drag, when received by a touch sensitive display of a device **212**, **248**, can be used, for instance, to relocate an icon or window to a desired location within a display, to reorder a stack on a display, or to span both displays (such that the selected window occupies a portion of each display simultaneously). A flick, when received by a touch sensitive display of a device **212**, **248** or a gesture capture region, can be used to relocate a window from a first display to a second display or to span both displays (such that the selected window occupies a portion of each display simultaneously). Unlike the drag gesture, however, the flick gesture is generally not used to move the displayed image to a specific user-selected location but to a default location that is not configurable by the user.

[0464] The pinch gesture, when received by a touch sensitive display or a gesture capture region of a device **212**, **248**, can be used to minimize or otherwise increase the displayed area or size of a window (typically when received entirely by a common display), to switch windows displayed at the top of the stack on each display to the top of the stack of the other display (typically when received by different displays or screens), or to display an application manager (a "pop-up window" that displays the windows in the stack). The spread gesture, when received by a touch sensitive display or a gesture capture region of a device **212**, **248**, can be used to maximize or otherwise decrease the displayed area or size of a window, to switch windows displayed at the top of the stack

on each display to the top of the stack of the other display (typically when received by different displays or screens), or to display an application manager (typically when received by an off-screen gesture capture region on the same or different screens).

[0465] The combined gestures of FIG. **11G**, when received by a common display capture region in a common display or screen of a device **212**, **248**, can be used to hold a first window location constant for a display receiving the gesture while reordering a second window location to include a window in the display receiving the gesture. The combined gestures of FIG. **11H**, when received by different display capture regions in a common display or screen of a device **212**, **248** or in different displays or screens of one more devices **212**, **248**, can be used to hold a first window location for a display receiving the tap part of the gesture while reordering a second window location to include a window in the display receiving the flick or drag gesture. Although specific gestures and gesture capture regions in the preceding examples have been associated with corresponding sets of functional results, it is to be appreciated that these associations can be redefined in any manner to produce differing associations between gestures and/or gesture capture regions and/or functional results.

[0466] Gestures that may be completed in three-dimensional space and not on a touch sensitive screen or gesture capture region of a device **212**, **248** may be as shown in FIGS. **11I-11K**. The gestures may be completed in an area where a sensor, such as an optical sensor, infrared sensor, or other type of sensor, may detect the gesture. For example, the gesture **1140** in FIG. **11I** may be executed by a person when the person opens their hand **1164** and moves their hand in a back and forth direction **1148** as a gesture **1140** to complete some function with the vehicle **104**. For example gesture **1140** may change the station of the radio in the vehicle **104**. The sensors **242** may both determine the configuration of the hand **1164** and the vector of the movement. The vector and hand configuration can be interpreted to mean certain things to the vehicle control system **204** and produce different results.

[0467] In another example of a gesture **1152** in FIG. **11J**, a user may configure their hand **1164** to extend two fingers and move the hand **1164** in an up and down operation **1156**. This gesture **1152** may control the volume of the radio or some other function. For instance, this gesture **1152** may be configured to place the vehicle in a "valet" mode to, among other things, restrict access to certain features associated with the vehicle. Again, the sensors **242** may determine how the person has configured their hand **1164**, and the vector of the movement. In another example of a gesture **1160** shown in FIG. **11K**, a user may extend their middle three fingers at an angle that is substantially 45° for vertical from straight vertical and circle the hand in a counter-clockwise motion **1166**. This gesture **1160** may cause the automobile to change the heat setting or do some other function. As can be understood by one skilled in the art, the configurations of the hand and the types of movement are variable. Thus, the user may configure the hand **1164** in any way imaginable and may also move that hand **1164** in any direction with any vector in three-dimensional space.

[0468] The gestures **1140**, **1152**, **1160**, as shown in FIGS. **11I-11K**, may occur in a predetermined volume of space within the vehicle **104**. For example, a sensor may be configured to identify such gestures **1140**, **1152**, **1160** between the front passenger's and front driver's seats over a console area within the passenger compartment of the vehicle **104**. The

gestures **1140**, **1152**, **1160** may be made within area **1 508A** between zones **A 512A** and **B 512B**. However, there may be other areas **508** where a user may use certain gestures, where sensors **242** may be able to determine a certain function is desired. Gestures that may be similar but used in different areas within the vehicle **104** may cause different functions to be performed. For example, the gesture **1140** in FIG. **11I**, if used in zone **E 512E**, may change the heat provided in zone **E 512E**, but may change the station of a radio if used in zone **A 512A** and/or zone **B 512B**. Further, the gestures may be made with other body parts or, for example, different expressions of a person's face and may be used to control functions in the vehicle **104**. Also, the user may use two hands in some circumstances or do other types of physical movements that can cause different reactions in the vehicle **104**.

[0469] FIGS. **12A-12D** show various embodiments of a data structure **1200** to store different settings. The data structure **1200** may include one or more of data files or data objects **1204**, **1250**, **1270**, **1280**. Thus, the data structure **1200** may represent different types of databases or data storage, for example, object-oriented databases, flat file data structures, relational database, or other types of data storage arrangements. Embodiments of the data structure **1200** disclosed herein may be separate, combined, and/or distributed. As indicated in FIGS. **12A-12D**, there may be more or fewer portions in the data structure **1200**, as represented by ellipses **1244**. Further, there may be more or fewer files in the data structure **1200**, as represented by ellipses **1248**.

[0470] Referring to FIG. **12A**, a first data structure is shown. The data file **1204** may include several portions **1208-1242** representing different types of data. Each of these types of data may be associated with a user, as shown in portion **1208**.

[0471] There may be one or more user records **1240** and associated data stored within the data file **1204**. As provided herein, the user can be any person that uses or rides within the vehicle or conveyance **104**. The user may be identified in portion **1212**. For the vehicle **104**, the user may include a set of one or more features that may identify the user. These features may be the physical characteristics of the person that may be identified by facial recognition or some other type of system. In other situations, the user may provide a unique code to the vehicle control system **204** or provide some other type of data that allows the vehicle control system **204** to identify the user. The features or characteristics of the user are then stored in portion **1212**.

[0472] Each user, identified in portion **1208**, may have a different set of settings for each area **508** and/or each zone **512** within the vehicle **104**. Thus, each set of settings may also be associated with a predetermined zone **512** or area **508**. The zone **512** is stored in portion **1220**, and the area **508** is stored in portion **1216**.

[0473] One or more settings may be stored in portion **1224**. These settings **1224** may be the configurations of different functions within the vehicle **104** that are specified by or for that user. For example, the settings **1224** may be the position of a seat, the position of a steering wheel, the position of accelerator and/or brake pedals, positions of mirrors, a heating/cooling setting, a radio setting, a cruise control setting, or some other type of setting associated with the vehicle **104**. Further, in vehicles adapted to have a configurable console or a configurable dash or heads-up display, the settings **1224** may also provide for how that heads-up display, dash, or console are configured for this particular user.

[0474] Each setting **1224** may be associated with a different area **508** or zone **512**. Thus, there may be more settings **1224** for when the user is the driver and in zone **A 512A**, **512A**, of area **1, 508A**. However, there may be similar settings **1224** among the different zones **512** or areas **508** as shown in portion **1224**. For example, the heating or radio settings for the user may be similar in every zone **512**.

[0475] The sensors **242** within the vehicle **104** may be able to either obtain or track health data in portion **1228**. Health data **1228** may include any type of physical characteristic associated with the user. For example, a heart rate, a blood pressure, a temperature, or other types of health data may be obtained and stored in portion **1228**. The user may have this health data tracked over a period of time to allow for statistical analysis of the user's health while operating the vehicle **104**. In this way, if some function of the user's health deviates from a norm (e.g., a baseline measurement, average measurements taken over time, and the like), the vehicle **104** may be able to determine there is a problem with the person and react to that data.

[0476] One or more gestures may be stored in portion **1232**. Thus, the gestures used and described in conjunction FIG. **11A** through **11K** may be configurable. These gestures may be determined or created by the user and stored in portion **1132**. A user may have different gestures for each zone **512** or area **508** within the vehicle. The gestures that do certain things while driving may do other things while in a different area **508** of the vehicle **104**. Thus, the user may use a first set of gestures while driving and a second set while a passenger. Further, one or more users may share gestures as shown in portion **1232**. Each driver may have a common set of gestures that they use in zone **A 512A**, **512A**. Each of these gestures may be determined or captured and then stored with their characteristics (e.g., vector, position of gesture, etc.) in portion **1232**.

[0477] One or more sets of safety parameters may be stored in portion **1236**. Safety parameters **1236** may be common operating characteristics for this driver/passenger or for all drivers/passengers that if deviated from may determine there is a problem with the driver/passenger or the vehicle **104**. For example, a certain route may be taken repeatedly and an average speed or mean speed may be determined. If the mean speed deviates by some number of standard deviations, a problem with the vehicle **104** or the user may be determined. In another example, the health characteristics or driving experience of the user may be determined. If the user drives in a certain position where their head occupies a certain portion of three-dimensional space within the vehicle **104**, the vehicle control system **204** may determine that the safety parameter includes the users face or head being within this certain portion of the vehicle interior space. If the user's head deviates from that interior space for some amount of time, the vehicle control system **204** can determine that something is wrong with the driver and change the function or operation of the vehicle **104** to assist the driver. This may happen, for example, when a user falls asleep at the wheel. If the user's head droops and no longer occupies a certain three dimensional space, the vehicle control system **204** can determine that the driver has fallen asleep and may take control of the operation of the vehicle **204** and the automobile controller **8104** may steer the vehicle **204** to the side of the road. In other examples, if the user's reaction time is too slow or some other safety parameter is not nominal, the vehicle control system **204** may determine that the user is inebriated or having some other medical

problem. The vehicle control system **204** may then assume control of the vehicle to ensure that the driver is safe.

[**0478**] Information corresponding to a user and/or a user profile may be stored in the profile information portion **1238**. For example, the profile information **1238** may include data relating to at least one of current data, historical data, a user preference, user habit, user routine, observation, location data (e.g., programmed and/or requested destinations, locations of parking, routes traveled, average driving time, etc.), social media connections, contacts, brand recognition (e.g., determined via one or more sensors associated with the vehicle **104**, a device **212**, **248**, etc.), audible recording data, text data, email data, political affiliation, preferred retail locations/sites (e.g., physical locations, web-based locations, etc.), recent purchases, behavior associated with the aforementioned data, and the like. The data in the profile information portion **1238** may be stored in one or more of the data structures **1200** provided herein. As can be appreciated, these one or more data structures may be stored in one or more memory locations. Examples of various memory locations are described in conjunction with FIG. 2.

[**0479**] One or more additional data fields may be stored in the linked data portion **1242** as data and/or locations of data. The linked data **1242** may include at least one of pointers, addresses, location identification, data source information, and other information corresponding to additional data associated with the data structure **1200**. Optionally, the linked data portion **1242** may refer to data stored outside of a particular data structure **1200**. For example, the linked data portion **1242** may include a link/locator to the external data. Continuing this example, the link/locator may be resolved (e.g., via one or more of the methods and/or systems provided herein, etc.) to access the data stored outside of the data structure **1200**. Additionally or alternatively, the linked data portion **1242** may include information configured to link the data objects **1204** to other data files or data objects **1250**, **1270**, **1280**. For instance, the data object **1204** relating to a user may be linked to at least one of a device data object **1250**, a vehicle system data object **1270**, and a vehicle data object **1280**, to name a few.

[**0480**] An embodiment of a data structure **1200** to store information associated with one or more devices is shown in FIG. 12B. The data file **1250** may include several portions **1216-1262** representing different types of data. Each of these types of data may be associated with a device, as shown in portion **1252**.

[**0481**] There may be one or more device records **1250** and associated data stored within the data file **1250**. As provided herein, the device may be any device that is associated with the vehicle **104**. For example, a device may be associated with a vehicle **104** when that device is physically located within the interior space **108** of the vehicle **104**. As another example, a device may be associated with a vehicle **104** when the device registers with the vehicle **104**. Registration may include pairing the device with the vehicle **104** and/or one or more of the vehicle systems (e.g., as provided in FIG. 3). In some cases, the registration of a device with a vehicle **104** may be performed manually and/or automatically. An example of automatic registration may include detecting, via one or more of the vehicle systems, that a device is inside the vehicle **104**. Upon detecting that the device is inside the vehicle **104**, the vehicle system may identify the device and determine whether the device is or should be registered. Reg-

istration may be performed outside of a vehicle **104** via providing a unique code to the vehicle **104** and/or at least one of the vehicle systems.

[**0482**] The device may be identified in portion **1256**. Among other things, the device identification may be based on the hardware associated with the device (e.g., Media Access Control (MAC) address, Burned-In Address (BIA), Ethernet Hardware Address (EHA), physical address, hardware address, and the like).

[**0483**] Optionally, a device may be associated with one or more users. For example, a tablet and/or graphical user interface (GUI) associated with the vehicle **104** may be used by multiple members of a family. For instance, the GUI may be located in a particular area **508** and/or zone **512** of the vehicle **104**. Continuing this example, when a family member is located in the particular area **508** and/or zone **512**, the device may include various settings, features, priorities, capabilities, and the like, based on an identification of the family member. The user may be identified in portion **1254**. For the device, the user identification portion **1254** may include a set of one or more features that may identify a particular user. These features may be the physical characteristics of the person that may be identified by facial recognition, or some other type of system, associated with the device and/or the vehicle **104**. Optionally, the user may provide a unique code to the device, or provide some other type of data, that allows the device to identify the user. The features or characteristics of the user are then stored in portion **1254**.

[**0484**] Each device identified in the device identification portion **1256** may have a different set of settings for each area **508** and/or each zone **512**, and/or each user of the device. Thus, each set of settings may also be associated with a predetermined zone **512**, area **508**, and/or user. The zone **512** is stored in portion **1220** and the area **508** is stored in portion **1216**.

[**0485**] One or more settings may be stored in portion **1224**. These settings **1224** may be similar and/or identical to those previously described. Further, the settings **1224** may also provide for how a device is configured for a particular user. Each setting **1224** may be associated with a different area **508** or zone **512**. Thus, there may be more restrictive settings **1224** (e.g., restricted multimedia, texting, limited access to device functions, and the like) for the device when the user is the driver and in zone A **512A**, **512A**, of area **1**, **508A**. However, when the user is in another zone **512** or area **508**, for example, where the user is not operating a vehicle **104**, the settings **1224** may provide unrestricted access to one or more features of the device (e.g., allowing texting, multimedia, etc.).

[**0486**] Optionally, the capabilities of a device may be stored in portion **1258**. Examples of device capabilities may include, but are not limited to, a communications ability (e.g., via wireless network, EDGE, 3G, 4G, LTE, wired, Bluetooth®, Near Field Communications (NFC), Infrared (IR), etc.), hardware associated with the device (e.g., cameras, gyroscopes, accelerometers, touch interface, processor, memory, display, etc.), software (e.g., installed, available, revision, release date, etc.), firmware (e.g., type, revision, etc.), operating system, system status, and the like. Optionally, the various capabilities associated with a device may be controlled by one or more of the vehicle systems provided herein. Among other things, this control allows the vehicle **104** to leverage the power and features of various devices to collect, transmit, and/or receive data.

[0487] One or more priorities may be stored in portion 1260. The priority may correspond to a value, or combination of values, configured to determine how a device interacts with the vehicle 104 and/or its various systems. The priority may be based on a location of the device (e.g., as stored in portions 1216, 1220). A default priority can be associated with each area 508 and/or zone 512 of a vehicle 104. For example, the default priority associated with a device found in zone 1 512A of area 1 508A (e.g., a vehicle operator position) may be set higher than an (or the highest of any) alternative zone 512 or area 508 of the vehicle 104. Continuing this example, the vehicle 104 may determine that, although other devices are found in the vehicle, the device, having the highest priority, controls features associated with the vehicle 104. These features may include vehicle control features, critical and/or non-critical systems, communications, and the like. Additionally or alternatively, the priority may be based on a particular user associated with the device. Optionally, the priority may be used to determine which device will control a particular signal in the event of a conflict.

[0488] Registration data may be stored in portion 1262. As described above, when a particular device registers with a vehicle 104, data related to the registration may be stored in the registration data portion 1262. Such data may include, but is not limited to, registration information, registration codes, initial registration time, expiration of registration, registration timers, and the like. Optionally, one or more systems of the vehicle 104 may refer to the registration data portion 1262 to determine whether a device has been previously registered with the vehicle 104. As shown in FIG. 12B, User 4 of Device 2 has not been registered. In this case, the registration data field 1262, for this user, may be empty, contain a null value, or other information/indication that there is no current registration information associated with the user.

[0489] Additionally or alternatively, the data structure 1200 may include a profile information portion 1238 and/or a linked data portion 1242. Although the profile information portion 1238 and/or the linked data portion 1242 may include different information from that described above, it should be appreciated that the portions 1238, 1242 may be similar, or identical, to those as previously disclosed.

[0490] An embodiment of a data structure 1200 to store information associated with one or more vehicle systems is shown in FIG. 12C. The data file 1270 may include several portions 1216-1279 representing different types of data. Each of these types of data may be associated with a vehicle system, as shown in portion 1272.

[0491] There may be one or more system records 1270 and associated data stored within the data file 1270. As provided herein, the vehicle systems may be any system and/or subsystem that is associated with the vehicle 104. Examples of various systems are described in conjunction with FIG. 3 and other related figures (e.g., systems 324-352, etc.). One example of a system associated with the vehicle 104 is the vehicle control system 204. Other systems may include communications subsystems 344, vehicle subsystems 328, and media subsystems 348, to name a few. It should be appreciated that the various systems may be associated with the interior space 108 and/or the exterior of the vehicle 104.

[0492] Each system may include one or more components. The components may be identified in portion 1274. Identification of the one or more components may be based on hardware associated with the component. This identification may include hardware addresses similar to those described in

conjunction with the devices of FIG. 12B. Additionally or alternatively, a component can be identified by one or more signals sent via the component. Such signals may include an Internet Protocol (IP), or similar, address as part of the signal. Optionally, the signal may identify the component sending the signal via one or more of a header, a footer, a payload, and/or an identifier associated with the signal (e.g., a packet of a signal, etc.).

[0493] Each system and/or component may include priority type information in portion 1276. Among other things, the priority type information stored in portion 1276 may be used by the various methods and systems provided herein to differentiate between critical and non-critical systems. Non-limiting examples of critical systems may correspond to those systems used to control the vehicle 104, such as, steering control, engine control, throttle control, braking control, and/or navigation informational control (e.g., speed measurement, fuel measurement, etc.) Non-critical systems may include other systems that are not directly related to the control of the vehicle 104. By way of example, non-critical systems may include media presentation, wireless communications, comfort settings systems (e.g., climate control, seat position, seat warmers, etc.), and the like. Although examples of critical and/or non-critical systems are provided above, it should be appreciated that the priority type of a system may change (e.g., from critical to non-critical, from non-critical to critical, etc.) depending on the scenario. For instance, although the interior climate control system may be classified as a non-critical system at a first point in time, it may be subsequently classified as a critical system when a temperature inside/outside of the vehicle 104 is measured at a dangerous level (e.g., sub-zero Fahrenheit, greater than 90-degrees Fahrenheit, etc.). As such, the priority type may be associated with temperature conditions, air quality, times of the day, condition of the vehicle 104, and the like.

[0494] Each system may be associated with a particular area 508 and/or zone 512 of a vehicle 104. Among other things, the location of a system may be used to assess a state of the system and/or provide how the system interacts with one or more users of the vehicle 104. As can be appreciated each system may have a different set of settings for each area 508 and/or each zone 512, and/or each user of the system. Thus, each set of settings may also be associated with a predetermined zone 512, area 508, system, and/or user. The zone 512 is stored in portion 1220 and the area 508 is stored in portion 1216.

[0495] One or more settings may be stored in portion 1224. These settings 1224 may be similar and/or identical to those previously described. Further, the settings 1224 may also provide for how a system is configured for a particular user. Each setting 1224 may be associated with a different area 508 or zone 512. For instance, a climate control system may be associated with more than one area 508 and/or zone 512. As such, a first user seated in zone 1 512A of area 1 508A may store settings related to the climate control of that zone 512A that are different from other users and/or zones 512 of the vehicle 104. Optionally, the settings may not be dependent on a user. For instance, specific areas 508 and/or zones 512 of a vehicle 104 may include different, default, or the same settings based on the information stored in portion 1224.

[0496] The various systems and/or components may be able to obtain or track health status data of the systems and/or components in portion 1278. The health status 1278 may include any type of information related to a state of the sys-

tems. For instance, an operational condition, manufacturing date, update status, revision information, time in operation, fault status, state of damage detected, inaccurate data reporting, and other types of component/system health status data may be obtained and stored in portion 1278.

[0497] Each component and/or system may be configured to communicate with users, systems, servers, vehicles, third parties, and/or other endpoints via one or more communication type. At least one communication ability and/or type associated with a system may be stored in the communication type portion 1279. Optionally, the communication types contained in this portion 1279 may be ordered in a preferential order of communication types. For instance, a system may be configured to preferably communicate via a wired communication protocol over one or more wired communication channels (e.g., due to information transfer speeds, reliability, and the like). However, in this instance, if the one or more wired communication channels fail, the system may transfer information via an alternative communication protocol and channel (e.g., a wireless communication protocol and wireless communication channel, etc.). Among other things, the methods and systems provided herein may take advantage of the information stored in the communication type portion 1279 to open available communication channels in the event of a communication channel failure, listen on other ports for information transmitted from the systems, provide a reliability rating based on the number of redundant communication types for each component, and more. Optionally, a component or system may be restricted from communicating via a particular communication type (e.g., based on rules, traffic, critical/non-critical priority type, and the like). In this example, the component or system may be forced by the vehicle control system 204 to use an alternate communication type where available, cease communications, or store communications for later transfer.

[0498] Additionally or alternatively, the data structure 1200 may include a profile information portion 1238 and/or a linked data portion 1242. Although the profile information portion 1238 and/or the linked data portion 1242 may include different information from that described above, it should be appreciated that the portions 1238, 1242 may be similar, or identical, to those as previously disclosed.

[0499] Referring now to FIG. 12D, a data structure 1200 is shown optionally. The data file 1280 may include several portions 1216-1286 representing different types of data. Each of these types of data may be associated with a vehicle, as shown in portion 1282.

[0500] There may be one or more vehicle records 1280 and associated data stored within the data file 1282. As provided herein, the vehicle 104 can be any vehicle or conveyance 104 as provided herein. The vehicle 104 may be identified in portion 1282. Additionally or alternatively, the vehicle 104 may be identified by one or more systems and/or subsystems. The various systems of a vehicle 104 may be identified in portion 1284. For example, various features or characteristics of the vehicle 104 and/or its systems may be stored in portion 1284. Optionally, the vehicle 104 may be identified via a unique code or some other type of data that allows the vehicle 104 to be identified.

[0501] Each system may be associated with a particular area 508 and/or zone 512 of a vehicle 104. Among other things, the location of a system may be used to assess a state of the system and/or provide how the system interacts with one or more users of the vehicle 104. As can be appreciated

each system may have a different set of settings for each area 508 and/or each zone 512, and/or each user of the system. Thus, each set of settings may also be associated with a predetermined zone 512, area 508, system, and/or user. The zone 512 is stored in portion 1220 and the area 508 is stored in portion 1216.

[0502] One or more settings may be stored in portion 1224. These settings 1224 may be similar and/or identical to those previously described. Further, the settings 1224 may also provide for how a vehicle and/or its systems are configured for one or more users. Each setting 1224 may be associated with a different area 508 or zone 512. Optionally, the settings may not be dependent on a particular user. For instance, specific areas 508 and/or zones 512 of a vehicle 104 may include different, default, or the same settings based on the information stored in portion 1224.

[0503] The various systems and/or components may be able to obtain or track health status data of the systems and/or components in portion 1278. The health status 1278 may include any type of information related to a state of the systems. For instance, an operational condition, manufacturing date, update status, revision information, time in operation, fault status, state of damage detected, inaccurate data reporting, and other types of component/system health status data may be obtained and stored in portion 1278.

[0504] One or more warnings may be stored in portion 1286. The warnings data 1286 may include warning generated by the vehicle 104, systems of the vehicle 104, manufacturer of the vehicle, federal agency, third party, and/or a user associated with the vehicle. For example, several components of the vehicle may provide health status information (e.g., stored in portion 1278) that, when considered together, may suggest that the vehicle 104 has suffered some type of damage and/or failure. Recognition of this damage and/or failure may be stored in the warnings data portion 1286. The data in portion 1286 may be communicated to one or more parties (e.g., a manufacturer, maintenance facility, user, etc.). In another example, a manufacturer may issue a recall notification for a specific vehicle 104, system of a vehicle 104, and/or a component of a vehicle 104. It is anticipated that the recall notification may be stored in the warning data field 1286. Continuing this example, the recall notification may then be communicated to the user of the vehicle 104 notifying the user of the recall issued by the manufacturer.

[0505] Additionally or alternatively, the data structure 1200 may include a profile information portion 1238 and/or a linked data portion 1242. Although the profile information portion 1238 and/or the linked data portion 1242 may include different information from that described above, it should be appreciated that the portions 1238, 1242 may be similar, or identical, to those as previously disclosed.

[0506] An embodiment of a method 1300 for storing settings for a user 216 associated with vehicle 104 is shown in FIG. 13. While a general order for the steps of the method 1300 is shown in FIG. 13, the method 1300 can include more or fewer steps or can arrange the order of the steps differently than those shown in FIG. 13. Generally, the method 1300 starts with a start operation 1304 and ends with an end operation 1336. The method 1300 can be executed as a set of computer-executable instructions executed by a computer system and encoded or stored on a computer readable medium. Hereinafter, the method 1300 shall be explained

with reference to the systems, components, modules, software, data structures, user interfaces, etc. described in conjunction with FIGS. 1-12.

[0507] A person may enter the vehicle space 108. One or more sensors 242 may then identify that a person is sitting within the vehicle 104, in step 1308. For example, sensors 242 in a seat, may determine that some new amount of weight has been registered. The amount of weight may fall within predetermined parameters (e.g., over a threshold, in a specific range, etc.). This weight may then be determined to be a person by one or more optical or other sensors 242. The vehicle control system 204 may then determine that a person is in a certain zone 512 or area 508. For example, the sensors 242 may send signals to the vehicle controls system 204 that an event has occurred. This information may be sent to the vehicle control system processor 304 to determine the zone 512 and area 508 where the event occurred. Further, the vehicle control system 204 may then identify the person, in step 1312.

[0508] The vehicle control system 204 can receive the information from the sensors 242 and use that information to search the database 1200 that may be stored within the system data 208. The sensor data may be compared to ID characteristics 1212 to determine if the person has already been identified. The vehicle control system 204 may also send the characteristic data from the sensors to the communication network 224 to a server 228 to compare the sensor data to stored data 232 that may be stored in a cloud system. The person's features can be compared to stored features 1212 to determine if the person in the vehicle 104 can be identified.

[0509] If the person has been identified previously and their characteristics stored in portion 1212, the method 1300 proceeds YES to step 1316 where that person may be identified. In identifying a person, the information associated with that person 1240 may be retrieved and provided to the vehicle control system 204 for further action. If a person cannot be identified by finding their sensor characteristics in portion 1212, the method 1300 proceeds NO to step 1320. In step 1320, the vehicle control system 204, using an application, may create a new record in table 1200 for the user. This new record may store a user identifier and their characteristics 1212. It may also store the area 508 and zone 512 in data portions 1216 and 1220. The new record may then be capable of receiving new settings data for this particular user. In this way, the vehicle 104 can automatically identify or characterize a person so that settings may be established for the person in the vehicle 104.

[0510] The input module 312 may then determine if settings are to be stored, in step 1324. Settings might be any configuration of the vehicle 104 that may be associated with the user. The determination may be made after receiving a user input from the user. For example, the user may make a selection on a touch sensitive display indicating that settings currently made are to be stored. In other situations, a period of time may elapse after the user has made a configuration. After determining that the user is finished making changes to the settings, based on the length of the period of time since the setting was established, the vehicle control system 204 can save the setting. Thus, the vehicle control system 204 can make settings automatically based on reaching a steady state for settings for user.

[0511] The vehicle control system 204 may then store the settings for the person, in step 1328. The user interaction subsystem 332 can make a new entry for the user 1208 in data

structure 1204. The new entry may be either a new user or a new settings listed in 1224. The settings may be stored based on the area 508 and zone 512. As explained previously, the settings can be any kind of configuration of the vehicle 104 that may be associated with the user in that area 508 and the zone 512.

[0512] The settings may also be stored in cloud storage, in step 1332. Thus, the vehicle control system 204 can send the new settings to the server 228 to be stored in storage 232. In this way, these new settings may be ported to other vehicles for the user. Further, the settings in storage system 232 may be retrieved, if local storage does not include the settings in storage system 208.

[0513] Additionally or alternatively, the settings may be stored in profile data 252. As provided herein, the profile data 252 may be associated with one or more devices 212, 248, servers 228, vehicle control systems 204, and the like. Optionally, the settings in profile data 252 may be retrieved in response to conditions. For instance, the settings may be retrieved from at least one source having the profile data if local storage does not include the settings in storage system 208. As another example, a user 216 may wish to transfer settings stored in profile data 252 to the system data 208. In any event, the retrieval and transfer of settings may be performed automatically via one or more devices 204, 212, 248, associated with the vehicle 104.

[0514] An embodiment of a method 1400 to configure the vehicle 104 based on stored settings is shown in FIG. 14. A general order for the steps of the method 1400 is shown in FIG. 14. Generally, the method 1400 starts with a start operation 1404 and ends with an end operation 1428. The method 1400 can include more or fewer steps or can arrange the order of the steps differently than those shown in FIG. 14. The method 1400 can be executed as a set of computer-executable instructions executed by a computer system and encoded or stored on a computer readable medium. Hereinafter, the method 1400 shall be explained with reference to the systems, components, modules, software, data structures, user interfaces, etc. described in conjunction with FIGS. 1-13.

[0515] The vehicle control system 204 can determine if a person is in a zone 512 or area 508, in step 1408. This determination may be made by receiving data from one or more sensors 242. The vehicle 104 can use facial recognition, weight sensors, heat sensors, or other sensors to determine whether a person is occupying a certain zone 512.

[0516] Using the information from the sensors 242, the vehicle control system 204 can identify the person, in step 1412. The vehicle control system 204 can obtain characteristics for the user currently occupying the zone 512 and compare those characteristics to the identifying features in portion 1212 of data structure 1204. Thus, the settings in portion 1224 may be retrieved by identifying the correct zone 512, area 508, and characteristics for the user.

[0517] The vehicle control system 204 can first determine if there are settings associated with the identified person for that zone 512 and/or area 508, in step 1416. After identifying the user by matching characteristics with the features in portion 1212, the vehicle control system 204 can determine if there are settings for the user for the area 1216 and zone 1220 the user currently occupies. If there are settings, then the vehicle control system 204 can make the determination that there are settings in portion 1224, and the vehicle control system 204 may then read and retrieve those settings, in step 1420. The settings may be then used to configure or react to the presence

of the user, in step 1424. Thus, these settings may be obtained to change the configuration of the vehicle 104, for example, how the position of the seats or mirrors are set, how the dash, console, or heads up display is configured, how the heat or cooling is configured, how the radio is configured, or how other different configurations are made.

[0518] Embodiments of a method 1500 for storing settings in cloud storage are shown in FIG. 15. A general order for the steps of the method 1500 is shown in FIG. 15. Generally, the method 1500 starts with a start operation 1504 and ends with an end operation 1540. The method 1500 can include more or fewer steps or can arrange the order of the steps differently than those shown in FIG. 15. The method 1500 can be executed as a set of computer-executable instructions executed by a computer system and encoded or stored on a computer readable medium. Hereinafter, the method 1500 shall be explained with reference to the systems, components, modules, software, data structures, user interfaces, etc. described in conjunction with FIGS. 1-14.

[0519] The vehicle control system 204 can determine if a person is in a zone 512 or area 508, in step 1508. As explained previously, the vehicle control system 204 can receive vehicle sensor data from vehicle sensors 242 that show a person has occupied a zone 512 or an area 508 of the vehicle 104. Using the vehicle sensor data, the vehicle control system 204 can determine characteristics of the person, in step 1512. These characteristics are compared to the features in portion 1212 of the data structure 1204. From this comparison, the vehicle control system 204 can determine if the person is identified within the data structure 1204, in step 1516. If there is a comparison and the person can be identified, the method 1500 proceeds YES to step 1520. However, if the person cannot be identified, the method 1500 proceeds NO, to step 1524.

[0520] In step 1520, the person is identified in portion 1208 by the successful comparison of the characteristics and the features. It should be noted that there may be a degree of variability between the characteristics and the features in portion 1212. Thus, the comparison may not be an exact comparison but may use methods known in the art to make a statistically significant comparison between the characteristics received from the sensors 242 and the features stored in portion 1212. In step 1524, the characteristics received from sensors 242 are used to characterize the person. In this way, the received characteristics may be used as an ID, in portion 1212, for a new entry for a new user in portion 1208.

[0521] The user may make one or more settings for the vehicle 104. The vehicle control system 204 may determine if the settings are to be stored, in step 1528. If the settings are to be stored, the method 1500 proceeds YES to step 1536. If the settings are not to be stored or if there are no settings to be stored, the method 1500 proceeds NO to step 1532. In step 1532, the vehicle control system 204 can retrieve the settings in the portion 1224 of the data structure 1204. Retrieval of the settings may be as described in conjunction with FIG. 14. If settings are to be stored, the vehicle control system 204 can send those settings to server 228 to be stored in data storage 232, in step 1536. Data storage 232 acts as cloud storage that can be used to retrieve information on the settings from other vehicles or from other sources. Thus, the cloud storage 232 allows for permanent and more robust storage of user preferences for the settings of the vehicle 104.

[0522] An embodiment of a method 1600 for storing gestures associated with the user is shown in FIG. 16. A general order for the steps of the method 1600 is shown in FIG. 16.

Generally, the method 1600 starts with a start operation 1604 and ends with an end operation 1640. The method 1600 can include more or fewer steps or can arrange the order of the steps differently than those shown in FIG. 16. The method 1600 can be executed as a set of computer-executable instructions executed by a computer system and encoded or stored on a computer readable medium. Hereinafter, the method 1600 shall be explained with reference to the systems, components, modules, software, data structures, user interfaces, etc. described in conjunction with FIGS. 1-15.

[0523] Vehicle control system 204 may receive sensor data from sensors 242 to determine a person is occupying a zone 512 in an area 508 of the vehicle 104, in step 1608. The sensor data may provide characteristics for the person, in step 1612. The vehicle control system 204 may then use the characteristics to determine if the person can be identified, in step 1616. The vehicle control system 204 may compare the characteristics to the features in portion 1212 for the people having been recognized and having data associated therewith. If a comparison is made between the characteristics and the features in portion 1212, the person can be identified, and the method 1600 proceeds YES to step 1620. If there is no comparison, the method 1600 may proceed NO to step 1624. In step 1620, the person may be identified by the vehicle control system 204. Thus, the person's features and associated data record 1240 may be determined and the user identified in portion 1208. If the person is not identified, the vehicle control system 204 can characterize the person, in step 1624, by establishing a new record in data structure 1204 using the characteristics, received from the sensors 242, for the features in portion 1212.

[0524] Thereinafter, the vehicle control system 204 may determine if gestures are to be stored and associated with the user, in step 1628. The vehicle control system 204 may receive user input on a touch sensitive display or some other type of gesture capture region which acknowledges that the user wishes to store one or more gestures. Thus, the user may create their own gestures such as those described in conjunction with FIGS. 11A-11K. These gestures may then be characterized and stored in data structure 1204. If there are gestures to be stored, the method 1600 proceeds YES to step 1636. If gestures are not to be stored the method 1600 may proceed NO to step 1632.

[0525] In step 1632, the vehicle control system 204 can retrieve current gestures from portion 1232, which are associated with user 1240. These gestures may be used then to configure how the vehicle 104 will react if a gesture is received. If gestures are to be stored, the vehicle control system 204 may store characteristics, in step 1636, as received from sensor 242 or from one more user interface inputs. These characteristics may then be used to create the stored gestures 1232, in data structure 1204. The characteristics may include what the gesture looks like or appears and also what affect the gesture should have. This information may then be used to change the configuration or operation of the vehicle 104 based on the gesture if it is received at a later time.

[0526] An embodiment of a method 1700 for receiving a gesture and configuring the vehicle 104 based on the gesture may be as provided in FIG. 17. A general order for the steps of the method 1700 is shown in FIG. 17. Generally, the method 1700 starts with a start operation 1704 and ends with an end operation 1728. The method 1700 can include more or fewer steps or can arrange the order of the steps differently

than those shown in FIG. 17. The method 1700 can be executed as a set of computer-executable instructions executed by a computer system and encoded or stored on a computer readable medium. Hereinafter, the method 1700 shall be explained with reference to the systems, components, modules, software, data structures, user interfaces, etc. described in conjunction with FIGS. 1-16.

[0527] A vehicle control system 204 can receive sensor data from vehicle sensors 242. The vehicle sensor data can be used by the vehicle control system 204 to determine that a person is in a zone 512 or area 508, in step 1708. The vehicle sensor data may then be used to compare against feature characteristics 1212 to identify a person, in step 1712. The vehicle control system 204 thereafter may receive a gesture, in step 1716. The gesture may be perceived by vehicle sensors 242 or received in a gesture capture region. The gesture may be as described in conjunction with FIGS. 11A-11K. Upon receiving the gesture, the vehicle control system 204 can compare the gesture to gesture characteristics in portion 1232, in step 1720. The comparison may be made so that a statistically significant correlation between the sensor data or gesture data and the gesture characteristic 1232 is made. Upon identifying the gesture, the vehicle control system 204 can configure the vehicle 104 and/or react to the gesture, in step 1724. The configuration or reaction to the gesture may be as prescribed in the gesture characteristic 1232.

[0528] An embodiment of a method 1800 for storing health data may be as shown in FIG. 18. A general order for the steps of the method 1800 is shown in FIG. 18. Generally, the method 1800 starts with a start operation 1804 and ends with an end operation 1844. The method 1800 can include more or fewer steps or can arrange the order of the steps differently than those shown in FIG. 18. The method 1800 can be executed as a set of computer-executable instructions executed by a computer system and encoded or stored on a computer readable medium. Hereinafter, the method 1800 shall be explained with reference to the systems, components, modules, software, data structures, user interfaces, etc. described in conjunction with FIGS. 1-17.

[0529] Vehicle control system 204 can receive sensor data from sensors 242. The sensor data may be used to determine that a person is in a zone 512 or area 508, in step 1808. The sensor data may then be used to determine characteristics of the person, in step 1812. From the characteristics, the vehicle control system 204 can determine if a person may be identified in data structure 1204, in step 1816. If it is determined that the person can be identified in step 1816, the method 1800 proceeds YES to step 1820. If the person cannot be identified, the method 1800 proceeds NO to step 1824. A person may be identified by matching the characteristics of a person from the sensor data to the features shown in portion 1212. If these comparisons are statistically significant, the person may be identified in portion 1208, in step 1820. However, if the person is not identified in portion 1208, the vehicle control system 204 can characterize the person using the vehicle sensor data, in step 1824. In this way, the vehicle control system 204 can create a new record for a new user in data structure 1204.

[0530] Thereinafter, the vehicle control system 204 may receive health and/or safety data from the vehicle sensors 242, in step 1828. The vehicle control system 204 can determine if the health or safety data is to be stored, in step 1832. The determination is made as to whether or not there is sufficient health data or safety parameters, in portion 1228 and 1236, to

provide a reasonable baseline data pattern for the user 1240. If there is data to be received and stored, the vehicle control system 204 can store the data for the person in portions 1228 and 1236 of the data structure 1204, in step 1832.

[0531] The vehicle control system 204 may then wait a period of time, in step 1836. The period of time may be any amount of time from seconds to minutes to days. Thereinafter, the vehicle control system 204 can receive new data from vehicle sensors 242, in step 1828. Thus, the vehicle control system 204 can receive data periodically and update or continue to refine the health data and safety parameters in data structure 1204. Thereinafter, the vehicle control system 204 may optionally store the health and safety data in cloud storage 232 by sending it through the communication network 224 to the server 228, in step 1840.

[0532] An embodiment of a method 1900 for monitoring the health of a user may be as shown in FIG. 19. A general order for the steps of the method 1900 is shown in FIG. 19. Generally, the method 1900 starts with a start operation 1904 and ends with an end operation 1928. The method 1900 can include more or fewer steps or can arrange the order of the steps differently than those shown in FIG. 19. The method 1900 can be executed as a set of computer-executable instructions executed by a computer system and encoded or stored on a computer readable medium. Hereinafter, the method 1900 shall be explained with reference to the systems, components, modules, software, data structures, user interfaces, etc. described in conjunction with FIGS. 1-18.

[0533] The vehicle control system 204 can receive health data from sensors 242. The health data may be received, in step 1908. The vehicle control system 204 may then compare the received health data to stored health parameters in portion 1228 or portion 1236, in step 1912. The comparison may check if there is statistically significant separation or disagreement between the received health data and the stored health data. Thus, the vehicle control system 204 can make a health comparison of the user based on a baseline of health data previously stored. A statistically significant comparison may include determining if there are any parameters more than three standard deviations from the average or norm, any parameter that is increasing or decreasing over a period of eight different measurements, a measurement that is more than two standard deviations from the norm more than three measurements consecutively, or other types of statistical comparisons.

[0534] If the vehicle control system 204 determines that measured health parameter does deviate from the norm, the vehicle control system 204 can determine whether the health data is within acceptable limits, in step 1916. If the health data is within acceptable limits, the method 1900 proceeds YES back to receiving new health data, in step 1908. In this way, the health data is periodically or continually monitored to ensure that the driver is in a healthy state and able to operate the vehicle. If the health data is not within acceptable parameters, the method 1900 may proceed NO to step 1924 where the vehicle control system 204 may react to the change in the health data. The reaction may include any measure to provide for the safety of the user, such as stopping the vehicle, beginning to drive the vehicle, driving the vehicle to a new location, such as a hospital, waking the driver with an alarm or other noise, or performing some other function that may help maintain the health or safety of the user.

[0535] The health data received may be a reaction from the driver. For example, the driver may call for help or ask the

vehicle for assistance. For example, the driver or passenger may say that they are having a medical emergency and ask the car to perform some function to help. The function to help may include driving the person to a hospital or stopping the car and calling for emergency assistance.

[0536] An embodiment of a traffic control system **2000** is shown in FIG. **20**. Traffic control system **2000** may control the traffic that proceeds on a roadway **2012** for some portion of the roadway **2012**. The roadway **2012** may be any street, lane, route, or pathway driven by automobiles, truck or other conveyances. The roadway may be portioned into two or more zones **2016**. Each zone **2016a** through **2016d** may be defined by extents represented by the dashed circles. The extents may be two or more delineations between the zones. These delineations or extents may be defined by a latitude and longitude, GPS coordinates, cross streets, or other physical boundaries. In other situations, the zones **2016** and their extents may be defined by a range of one or more antennas and transceivers **2008A** through **2008D**.

[0537] The antennas and transceivers **2008A** through **2008D** can be any hardware, software, or hardware and software operable to send and receive wireless signals. The antennas and transceivers **2008A** through **2008D** may operate similar to cellular antennas and transceivers. The antennas, transceivers **2008A** through **2008D** can communicate with automobiles within the zone **2016** associated with that antenna or transceiver **2008**. Thus as an automobile enters the extents of the zone **2016A**, the antenna **2008A** may generate a signal that is transmitted to the car, may receive signals from that car and determine when the car, automobile, or conveyance leaves the zone **2016A**.

[0538] The transceivers **2008A** may then communicate with one or more control servers **2004A** through **2004g**. The control servers **2004** may be as described in conjunction with FIG. **21**. Further, the control servers **2004A** through **2004G** may include one or more software modules that may be as described in conjunction with FIG. **21**. The control modules **2004A** through **2004G** may be in communication with each other and may process any signals or conduct any operations needed to control the traffic on the roadway **2012**.

[0539] FIG. **43** illustrates a block diagram of a computing environment **4300** that may embody the computing environment for the two or more control servers **2004**. The environment **4300** includes one or more user computers **4305**, **4310**, and **4315**. The user computers **4305**, **4310**, and **4315** may be general purpose personal computers (including, merely by way of example, personal computers, and/or laptop computers running various versions of Microsoft Corp.'s Windows □ and/or Apple Corp.'s Macintosh □ operating systems) and/or workstation computers running any of a variety of commercially-available UNIX□ or UNIX-like operating systems. These user computers **4305**, **4310**, **4315** may also have any of a variety of applications, including for example, database client and/or server applications, and web browser applications. Alternatively, the user computers **4305**, **4310**, and **4315** may be any other electronic device, such as a thin-client computer, Internet-enabled mobile telephone, and/or personal digital assistant, capable of communicating via a network **4320** and/or displaying and navigating web pages or other types of electronic documents. Although the exemplary computer environment **4300** is shown with three user computers, any number of user computers may be supported.

[0540] Environment **4300** further includes a network **4320**. The network **4320** may be any type of network familiar to

those skilled in the art that can support data communications using any of a variety of commercially-available protocols, including without limitation SIP, TCP/IP, SNA, IPX, Apple-Talk, and the like. Merely by way of example, the network **4320** maybe a local area network ("LAN"), such as an Ethernet network, a Token-Ring network and/or the like; a wide-area network; a virtual network, including without limitation a virtual private network ("VPN"); the Internet; an intranet; an extranet; a public switched telephone network ("PSTN"); an infra-red network; a wireless network (e.g., a network operating under any of the IEEE 802.11 suite of protocols, the Bluetooth □ protocol know and/or any combination of these and/or other networks.

[0541] The system may also include one or more server **4325**, **4330**. In this example, server **4325** is shown as a web server and server **4330** is shown as an application server. The web server **4325**, which may be used to process requests for web pages or other electronic documents from user computers **4305**, **4310**, and **4315**. The web server **4325** can be running an operating system including any of those discussed above, as well as any commercially-available server operating systems. The web server **4325** can also run a variety of server applications, including SIP servers, HTTP servers, FTP servers, CGI servers, database servers, Java servers, and the like. In some instances, the web server **4325** may publish operations available operations as one or more web services.

[0542] The environment **4300** may also include one or more file and/or application servers **4330**, which can, in addition to an operating system, include one or more applications accessible by a client running on one or more of the user computers **4305**, **4310**, **4315**. The server(s) **4330** and/or **4325** may be one or more general purpose computers capable of executing programs or scripts in response to the user computers **4305**, **4310** and **4315**. As one example, the server **4330**, **4325** may execute one or more web applications. The web application may be implemented as one or more scripts or programs written in any programming language, such as Java™, C, C#, or C++, and/or any scripting language, such as Perl, Python, or TCL, as well as combinations of any programming/scripting languages. The application server(s) **4330** may also include database servers, including without limitation those commercially available from Oracle, Microsoft, Sybase™, IBM™ and the like, which can process requests from database clients running on a user computer **4305**.

[0543] The web pages created by the server **4325** and/or **4330** may be forwarded to a user computer **4305** via a web (file) server **4325**, **4330**. Similarly, the web server **4325** may be able to receive web page requests, web services invocations, and/or input data from a user computer **4305** and can forward the web page requests and/or input data to the web (application) server **4330**. In further embodiments, the web server **4330** may function as a file server. Although for ease of description, FIG. **6** illustrates a separate web server **4325** and file/application server **4330**, those skilled in the art will recognize that the functions described with respect to servers **4325**, **4330** may be performed by a single server and/or a plurality of specialized servers, depending on implementation-specific needs and parameters. The computer systems **4305**, **4310**, and **4315**, web (file) server **4325** and/or web (application) server **4330** may function as the system, devices, or components described herein.

[0544] The environment **4300** may also include a database **4335**. The database **4335** may reside in a variety of locations.

By way of example, database **4335** may reside on a storage medium local to (and/or resident in) one or more of the computers **4305**, **4310**, **4315**, **4325**, **4330**. Alternatively, it may be remote from any or all of the computers **4305**, **4310**, **4315**, **4325**, **4330**, and in communication (e.g., via the network **4320**) with one or more of these. The database **4335** may reside in a storage-area network (“SAN”) familiar to those skilled in the art. Similarly, any necessary files for performing the functions attributed to the computers **4305**, **4310**, **4315**, **4325**, **4330** may be stored locally on the respective computer and/or remotely, as appropriate. The database **4335** may be a relational database, such as Oracle 10i □, that is adapter and retrieve data in response to SQL-formatted commands.

[0545] FIG. 44 illustrates one embodiment of a computer system **4400** upon which the control servers **2004** described herein may be deployed or executed. The computer system **4400** is shown comprising hardware elements that may be electrically coupled via a bus **4455**. The hardware elements may include one or more central processing units (CPUs) **4405**; one or more input devices **4410** (e.g., a mouse, a keyboard, etc.); and one or more output devices **4415** (e.g., a display device, a printer, etc.). The computer system **4400** may also include one or more storage devices **4420**. By way of example, storage device(s) **4420** may be disk drives, optical storage devices, solid-state storage devices such as a random access memory (“RAM”) and/or a read-only memory (“ROM”), which can be programmable, flash-updateable and/or the like.

[0546] The computer system **4400** may additionally include a computer-readable storage media reader **4425**; a communications system **4430** (e.g., a modem, a network card (wireless or wired), an infra-red communication device, etc.); and working memory **4440**, which may include RAM and ROM devices as described above. The computer system **4400** may also include a processing acceleration unit **4435**, which can include a DSP, a special-purpose processor, and/or the like.

[0547] The computer-readable storage media reader **4425** can further be connected to a computer-readable storage medium, together (and, optionally, in combination with storage device(s) **4420**) comprehensively representing remote, local, fixed, and/or removable storage devices plus storage media for temporarily and/or more permanently containing computer-readable information. The communications system **4430** may permit data to be exchanged with the network **4320** (FIG. 43) and/or any other computer described above with respect to the computer system **4400**. Moreover, as disclosed herein, the term “storage medium” may represent one or more devices for storing data, including read only memory (ROM), random access memory (RAM), magnetic RAM, core memory, magnetic disk storage mediums, optical storage mediums, flash memory devices and/or other machine readable mediums for storing information.

[0548] The computer system **4400** may also comprise software elements, shown as being currently located within a working memory **4440**, including an operating system **4445** and/or other code **4450**. It should be appreciated that alternate embodiments of a computer system **4400** may have numerous variations from that described above. For example, customized hardware might also be used and/or particular elements might be implemented in hardware, software (including portable software, such as applets), or both. Further, connection to other computing devices such as network input/output devices may be employed.

[0549] An embodiment of the one or more modules that may be executed by the one or more control servers **2004** may be as shown in FIG. 21. The control server modules may include hardware, software, or hardware and software components. The control server software may include one or more of, but is not limited to, a registration module **2104**, a traffic control module **2108**, a message communication module **2112**, a node formation module **2116**, an accident reporting, a control module **2120**, a redundancy module **2124**, a zonal communication module **2128**, and/or an advertising module **2132**. These several modules **2104** through **2132** may communicate with one or more databases, for example, a queues database **2136** and/or a consumer data database **2140**. Each of these several modules **2104** through **2140** may be as described hereinafter.

[0550] A registration module **2104** may be operable to communicate with vehicles entering into the traffic control area **2020** defined by one or more zones **2016**. Once the registration module **2104** initiates contact with the automobile, the registration module **2104** may register that automobile in the traffic control system **2000** and provide that automobile or conveyance with information that allows that automobile to be controlled by the traffic control system **2000**.

[0551] A traffic control module **2108** is operable to communicate with any conveyance in the traffic control system **2000** and registered by the registration module **2104**. The traffic control module **2108** can send messages that dictate to the automobile or conveyance how to operate within the traffic system **2000**. For example, the traffic control module **2108** can assign the car to a certain position on the roadway **2012** and dictate how that car is to proceed based on speed and distance of separation between vehicles around the automobile. The traffic control module **2108** is operable to send one or more messages that may as defined in conjunction with FIGS. 23-27 that may dictate how the automobile is to function. In this way, the traffic control module **2108** is operable to manage any traffic within the traffic control system **2000**.

[0552] The traffic control module **2108** may also be able to be able to write, read, or manage data within the one or more queues **2136**. The queues **2136** may be stored in any type of database that may be described in conjunction with FIG. 20B. The queues **2136** administer information that may be as described in conjunction with FIGS. 23-27 that allow for the storage of information about vehicles within the traffic control system **2000**.

[0553] The message communication module **2112** is operable to send possible or active control messages or other information to the conveyances within the traffic control system **2000**. As such, the message communication module **2112** can format messages based on data within queues or provided by one or more of the other modules within the control server **2004**. The message control module **2112** can may send this information to a transceiver to send to one or more of the conveyances. The message communication module **2112** can also receive messages.

[0554] A node formation module **2116** may provide information that allows the one or more conveyances to establish nodes of two or more vehicles or conveyances in the traffic system **2000**. Nodes may be groupings of two or more conveyances that virtualize the group as a single entity. As such, one message to a member of the node may be forwarded by those node members to other members within the node. In this way, the control server **2004** may send messages to two or

more vehicles with one message and with less bandwidth or communication requirements. The node formation module 2116 can provide information for a car to either establish or join a node and may receive any information from the node that dictates which members are currently in the node.

[0555] An accident reporting and control module 2112 may detect, determine, and react to any possible accident or other hazardous situation on the roadway 2012. The accident and reporting control module 2112 may receive information from one or more vehicles that indicates that something is not within normal parameters within the traffic control system 2000. For example, if two or more cars suddenly have a quick shift in speed or direction, those changes may indicate that there is an accident or a roadway obstacle. This information can be reported by the conveyances to the accident reporting and control module 2120. From that information the accident reporting and control module 2120 may determine where the accident or obstacle is located and then may use that information to send signals to the traffic control module 2108 to adjust how the traffic should proceed through that area.

[0556] A redundancy module 2124 is operable to communicate with one or more other control servers 2004. The redundancy module 2124 can duplicate information from another control server 2004 to allow for quick fail over should one of the control servers fail. This queue information may be stored by the redundancy module 2124 in a section of the database 2136. As such, the fail over may occur immediately or with very little obstruction of performance for the control server 2004. This configuration assures the safety of those participants in the traffic control system 2000.

[0557] A zonal communication module 2128 is operable to both define and administer zone handoffs between two or more control servers 2004. The zonal communication module 2128 can determine if a conveyance is entering or leaving a zone and/or entering or leaving a zone that is adjacent to one controlled by the current control server 2004. On detecting a change in zones, the zonal communication module 2128 can administer any of the communications between the control servers 2004 to ensure that the conveyance is changed from the queue for that zone 2016 to another queue associated with the different zone 2016.

[0558] An advertising module 2132 may access consumer data 2140. The consumer data 2140 may be stored in any database as explained in conjunction with FIG. 29. The consumer data 2140 may include any information about the people or passengers within the conveyances within that zone 2016. The advertising module 2132 may also receive information from the node formation module 2116 or traffic control module 2108. This information may be analyzed, by the advertising module 2132, to determine advertising that may be associated with two or more vehicles in the zone 2016. Advertising may be displayed on billboards or roadside signs, which may be adjusted automatically and in near real-time to provide advertising to those two or more vehicle while those vehicles are within the zone 2016.

[0559] An embodiment of a traffic controller module 8112 may be as shown in FIG. 22. The traffic controller module 8112 can include one or more modules including, but not limited to, a registration module 2104, a traffic control module 2108, a message communication module 2112, a node formation module 2116, an accident control module 2120, and a consumer module 2204. The modules 2104-2120 may operate as described in conjunction with FIG. 21.

[0560] A consumer module 2204 may be operable to save and to provide information about the shopping or consumer habits of the user. This information may be stored in a profile 1200, as described in conjunction with FIGS. 12A through 12D. The information may be collected and sent to an advertising module 2132, which is part of the control server 2004.

[0561] The node database 2208 may provide information to the node formation database 2116. The node database 2008 may be any type of databases described in conjunction with FIG. 24. The node database 2208 can store, retrieve or manage data both for forming nodes and for exchanging messages between node members.

[0562] A queue database 2136 can include the same or similar information as queue database 2136, described in conjunction with FIG. 21. The queue data may be used by the traffic controller module 8112 to receive or send messages from or to the traffic control system 2000.

[0563] An embodiment of registration information and queue data that may be stored within queue database 2136 or exchanged between the control server 2004 and the traffic controller 8112 may be as shown FIG. 23. The database 2300 can include one or more fields that may be stored as a flat file database, relational database, object oriented database, etc. These one or more fields may include information that may be used to manage the traffic control system 2000 or may be used by a vehicle to determine how to operate within the traffic control system 2000. The information can include one or more of the fields shown in FIG. 23 but may not be limited to those fields or may have fewer fields than those shown in FIG. 23, as represented by ellipses 2396. Each of the several fields and the information contained therein will be described hereinafter.

[0564] A vehicle identifier (ID) field or identifier field 2304 can provide a unique identifier for the automobile. This identifier 2304 may be used to send messages to that vehicle, while in the traffic control system 2000. The car identifier 2304 may be static such that it is produced one time and stored thereafter by the car and used, by that automobile, for any interaction with the traffic control system 2000. In other situations, that car identifier 2304 is dynamically generated upon any contact with the traffic control system 2000. The car identifier 2304 can be a numeric, alpha numeric, globally unique identifier (GUID), or any other type of identifier.

[0565] A destination field 2304 may include the destination of the automobile on the route currently being traveled. The destination 2304 may be provided as a GPS coordinate, a latitude/longitude, a physical address, some other graphical information system data or other type of data. The destination 2308 may be provided by a user entering such information into the traffic controller 8112.

[0566] The position field 2312 can include the current position of the vehicle. The position 2312 may be a GPS coordinate, an address, or some other type of designation of the current physical location of the vehicle. The position 2312 may be updated periodically or continually for interactions with the traffic control system 2000.

[0567] The node identifier 2316 can include any information to identify the node to which the current vehicle is a member of or to which the automobile desires to join. The node identifier 2316 can be any type of identifier as are already described herein.

[0568] The node controller identifier 2320 can include the identity of the automobile acting as the controller for the node identified by node ID 2316. As such, the node controller

identifier **2320** can refer to a car ID **2304** of the node controller. The node controller is the automobile that may send information to the other members of the node such that the traffic control system **2000** need only communicate with node controller to send messages to the entire group of automobiles within the node.

[0569] The inbound estimated time of arrival (ETA) **2324** is a time predicted by the automobile to arrive at an entry point to the roadway **2012**. This inbound ETA **2324** allows the traffic control server **2004** to determine spacing and distribution of automobile needs. Further, the control server **2004** may create a space to merge the vehicle onto the roadway **2012** based on the inbound ETA **2324**.

[0570] A poll timer **2328** may provide a time period or amount of minutes or seconds used by the vehicle and/or the control server **2004** to contact the vehicle. The pull timer **2328** may be set such that when the vehicle is inbound to the traffic control system **2000**, the traffic controller **8112** knows to contact and update the control server **2004** with the current position **2312** and/or the inbound ETA **2324**. This poll timer **2328** allows the control server **2004** to continually update the desired entry point for the vehicle.

[0571] An entry/exit field **2332** includes the information for the vehicle on their positioning to enter or exit the roadway **2012**. Thus, this information allows the vehicle to understand where within the traffic this vehicle is meant to be positioned when transitioning out of or into the traffic control system **2000**. As such, the entry/exit field **2312** can include a when field **2364** which includes a time for when the vehicle should merge. This timing **2364** may be a set time or number of seconds or minutes until which the car is needed to merge. The when field **2364** should correlate to an opening within the traffic that is positioned for the car to move into.

[0572] A lane field **2368** includes the lane upon which the car should move to. As such, if the user or vehicle is provided with a third lane, the vehicle must merge across the first and second lanes to enter the third lane. This lane marker **2368** provides the information for which lane position the vehicle should obtain.

[0573] A speed field **2372** includes the speed upon which the vehicle should obtain when transitioning in the traffic control system **2000**.

[0574] The location field **2376** includes a location within the traffic and the lane upon which the vehicle should enter and remain or exit. This location **2376** may include a mile marker or be designated by some other geographical information.

[0575] A surrounding vehicle field **2380** can include the car ID **2304** for the car that should be in front, back, or to the sides of the vehicle. As such, the vehicle may be able to ascertain the exact positioning between vehicles upon which the vehicle should obtain. As this "position" moves because the cars are moving, the surrounding vehicles provide a location for the vehicle in traffic when traveling in this traffic control system **2000**.

[0576] The entry/exit information **2332** may also be changed or be modified as the vehicle enters the traffic control system **2000** or exits the traffic control system **2000**. As such, this information may be provided periodically to allow the automobile to merge into traffic or to exit the roadway **2012**.

[0577] The speed field **2336** may include a speed upon which the vehicle should obtain or maintain while inside the traffic control system **2000**. The auto information field **2340**

can include any information about the vehicle that may be sent to the traffic control server **2004** for determination of how to manage the automobile.

[0578] A last contact field **2344** can include information for when this vehicle was last entered into the traffic control system **2000**. The field **2344** may also include information upon which the vehicle should contact the traffic control system **2000** to receive instructions.

[0579] A position field **2348** may include information about the permanent position upon which the vehicle should maintain within the traffic on the roadway **2012**. As such, the position information **2348** can include a lane designation **2384**, a GPS coordinate **2388**, a street name **2392**, a traffic location, etc. This information **2348** may also be used to determine a current origin, such as position **2312**.

[0580] The exit information **2352** may be the information designated by the automobile to the traffic control system **2000** about when the automobile wishes to exit to maintain their desired travel route. Further, this information **2352** may also be designated by the control server **2004** and provided to the automobile to manage that route based on the exit chosen by the traffic control system **2000**.

[0581] A distance to exit **2356** may include the amount of miles, feet, etc. used to measure where the current position **2312** is compared to the exit **2352** upon which the vehicle needs to exit. This distance **2356** may be used by the vehicle to begin to merge out of the traffic on the roadway **2012**.

[0582] The estimated time of departure **2360** can include an amount of time expected to reach the exit **2352**. This information may be based on the distance to exit **2356** and the speed **2336** maintained by the vehicle.

[0583] An embodiment of a database **2400** that includes information for node formation or node management is shown at FIG. **24**. The information within database **2400** can include one or more fields, but is not limited to those shown in FIG. **24**, as represented by ellipses **2424**.

[0584] The car identifier **2404** can include the two or more car ID's **2304** for each of the vehicles that are part of the node. As such, the node database **2400** shows only a single record for one car within the node. However, there may be two or more records provided, within the database **2400**, as represented by ellipses **2428**. The two or more car ID's **2404** can be associated with a single node identifier **2408**. This node identifier **2408** may be the same or similar to node ID **2316**. The node identifier **2408** can include any kind of numeric, alpha numeric, GUID, or other designator that uniquely identifies the node amongst all other nodes within the traffic control system **2000**.

[0585] The node controller ID **2412** may be the same or similar to node controller ID **2320**, described in FIG. **23**. The node controller ID **2412** can include the information for the automobile that controls or distributes the messages to the node. The node controller ID **2412** may be the same or similar to one of the car ID's **2404**.

[0586] One or more types of messages may be sent with this information such as a node reformation message **2416**. The message designation for node formation may be the indication that the node needs to be reformed because of the loss of a member. This node reformation designation **2416** may occur when the node controller automobile leaves the node. As such, a new controller may need to be determined and that car ID **2404** is provided as the node controller **2412**. Thus, the node reformation designation **2416** may be selected to have one of the members assume the role of the node controller.

[0587] A node request 2420 may be any type of message sent or received that requires action by one or more node members. This node request 2420 can also include any requests by one of the node members to the traffic control system 2000 or the node in general. These node requests 2420 can include any information exchange between vehicles or between one or more of the vehicles and the traffic control system 2000.

[0588] An embodiment of a passive message 2500 sent between the traffic control system 2000 and the automobile is shown in FIG. 25. A passive message 2500 is a minimal set of data that may be exchanged between the control server 2004 and the traffic controller 8112 to control the function of the vehicle. With the passive message 2500, it is assumed that the traffic controller 8112 can manage most or all of the functions of driving or operating the vehicle. Thus, the control server 2004 is required to send only a minimal amount of data to have the vehicle enter the traffic control system 2000 and maintain its position within that system 2000. Thus, there is a minimal amount of information that may be provided in any passive message 2500. For example, the passive message 2500 can include a car identifier 2504, which may be the same or similar to car ID 2304, a lane identifier 2508, which may be the same or similar to lane identifiers 2368 or 2384, a time field 2512, which may be the same or similar to the when field 2364 or the ETD field 2360. Each of these fields may be provided in a communication to control the operation of the vehicle. There may be more or fewer fields shown in FIG. 25, as represented by ellipses 2516.

[0589] An embodiment of an active message 2500 may be as shown in FIG. 26. An active message 2600, unlike the passive message 2500, may include more information required by the traffic controller 8112 to operate within the traffic control system 2000. Active messages 2600 may be sent when the traffic control server 2004 determines that a detailed set of instructions are required for management of the vehicle within the traffic control system 2000. There may be more fields within the message 2600 than those shown in FIG. 26, as represented by ellipses 2648. The one or more fields within the active message 2600 may be as shown in FIG. 26 and described hereinafter.

[0590] An ID field 2604 may be the same or similar to car ID 2304; the lane designator 2607 may be the same or similar to lane designator 2368 or 2384. The speed field 2612 may be the same or similar to speed field 2336 or 2372 described in conjunction with FIG. 23.

[0591] The distance forward field 2616 may provide a specific distance that must be maintained between the vehicle and the car or conveyance in front of the current conveyance. This distance 2616 may be designated in feet or some other unit of length. The distance 2616 may be required within some range of tolerance. The distance 2616 ensures that the cars maintain their correct spacing while in the traffic control system 2000. Similarly, a distance backward field 2620 may provide a distance that should be maintained between the car and the car in front of it. This distance 2620 may also have some sort of tolerance. In this way, the vehicles may operate within the roadway 2012 while maintaining a distance in front and behind each of the vehicles.

[0592] An entry time field 2624 may be the same or similar to the inbound ETA 2324 or the when field 2364. This information can be required by the control server 2004 for the car to enter the roadway. The exit time 2628 may include a time similar to the ETD 2360 or the when field 2364. This infor-

mation 2628 may be provided for when the vehicle should leave the traffic control system 2000.

[0593] A car forward and a car back field 2632 and 2636, respectively, provide the car ID's 2304 for the automobiles or conveyances that should be in front and back of the vehicle. This information 2632, 2636 ensures that the automobile can maintain or is in the correct position within the traffic control system 2000.

[0594] A node assignment field 2640 and node controller field 2644, respectively can include the information as described in conjunction with the node information 2400 for the vehicle to join a node of vehicles surrounding the current conveyance.

[0595] An embodiment of a burst message 2700 may be as shown in FIG. 27. A burst message 2700 may be sent when an accident or other problem occurs within the traffic control system 2000. A burst message 2700 is a broadcast message that can be received by multiple vehicles at the same time or as substantially the same time. The difference between the timing of the receptions may be only dictated by communication delays or latencies. The burst message 2700 may include one or more fields that have specific information for automobiles to adjust to the hazard or accident on the roadway 2012. There may be more or fewer fields in the burst messages, as indicated by ellipses 2716.

[0596] The burst message 2700 can include a general identifier 2704. The general identifier 2709 may be similar to the car identifier 2304 but may be received by each traffic controller 8112 and understood to apply to that vehicle as a general identifier. As such, the general ID 2709 may be a part of the car ID 2304 or may be a different type of identifier that may be sent to the traffic controller 8112 and recognized as applying to that traffic controller 8112 along with other conveyances. The general identifier 2709 may be sent to all vehicles or may be sent to only a portion of the vehicles. For example, if all cars within a third lane must move to a second lane to avoid an accident within the third lane, the general identifier 2704 may only apply to the vehicles within the third lane. As such, the general identifier 2704 can have different forms and provide information to the traffic controller 8112 as to whether or not the message applies to that vehicle.

[0597] A lane identifier 2708 may be the same or similar to lane identifier 2368 or 2384. This lane identifier 2708 provides a location for the car to move to a different lane to avoid an accident or other obstacle. The speed field 2712 may be the same or similar to the speed field 2372 or 2336. The speed field 2712 may be included to slow the speeds of the vehicles to ensure safe passage past the accident.

[0598] A handoff message 2800, in FIG. 28, may occur between different control servers 2009 that are associated with different zones 2016. The handoff occurs when an automobile travels out of one zone 2016A and into a different zone 2016B. The different control servers 2009 must exchange information between themselves or between the traffic controller 8112 to maintain control of the vehicle, while on the roadway 2012 and while traveling through the different zones 2016. As such, the handoff message 2800 can include information for the traffic controller 8112 or the control server 2004 to maintain control. The handoff message 2800 may have more or fewer fields than those shown in FIG. 28 as represented by ellipses 2824.

[0599] An identifier 2804 may be the same or similar to car identifier 2304, described in conjunction with FIG. 23. A current controller identifier 2808 can include any type of

identifier, such as an alpha numeric, a numeric, a GUID, a symbolic, or other identifier that identifies the control server **2004**. The controller server ID **2004** applies to the control server **2004** that currently is communicating with the automobile. Another identifier, for a new control server **2004**, is provided in field **2812**. The new controller ID **2812** can be the same or similar in format to the ID **2808** but identifies a different control server **2004**. Thus, this identifier information can be provided to the traffic controller **8112** to receive and accept messages from a different control server **2004** and meant for that automobile. Further, this identifier information may be exchanged between control servers **2004** to understand which control server **2004** will take operation of the vehicle.

[**0600**] Contact information **2816** may include any kind of information for the control server **2004** or the traffic controller **8112** to contact the new control server **2004** or the automobile. This contact information **2816** may be exchanged between parties, such that contact may be maintained, while the automobile travels through different zones **2016**.

[**0601**] Message identifier **2820** may include any kind of information about a message that needs to be sent or has been sent or is being sent to the traffic controller **8112** or to the control server **2004**. The message ID **2820** can include such information as an indication that this is a handoff message or other information needed to maintain communication with the automobile.

[**0602**] An embodiment of an advertising message **2900** or advertising information that may be exchanged in the traffic control system **2000**, is shown in FIG. **29**. Advertising information **2900** may be sent from a profile **1238**, through a consumer module **2204**, to the advertising module **2132**. Consumer information can include the information described in message **2900** or may include more information or less information than that shown in FIG. **29**, as represented by ellipses **2916**.

[**0603**] The advertising message **2900** can include an identifier **2904** which may include a user identifier from the profile information **1238**. This identifier **2904** can identify a user or person within the vehicle. The identifier **2904** may also have associated consumer information **2908**, which may be a part of the profile **1238**. This consumer information **2908** may include any type of information locally stored at the car that gives an indication of products or services that the user may be interested in.

[**0604**] A consumer ID **2912** may be extracted from the profile information **1238** or may be provided or referenced, such that consumer data **2140** may be accessed. The consumer ID **2912** can include any information that may identify this user within the consumer data **2140**. Thus, the advertising module **2132** can access information about the person in the consumer data **2940** by using the consumer ID **2912**. This accessed information can be provided to the advertising module **2132** to determine products or services the user may be interested in and to market those services to the user while they are driving, by changing the configuration of one or more billboards encountered by the user while driving the route they are on in the traffic control system **2000**.

[**0605**] An embodiment of a method **3000** for registering a vehicle with a traffic control system **2000** is shown in FIG. **30**. A general order for the steps of the method **3000** is shown in FIG. **30**. Generally, the method **3000** starts with a start operation **3004** and ends with an end operation **3028**. The method **3000** can include more or fewer steps or can arrange the order

of the steps differently than those shown in FIG. **30**. The method **3000** can be executed as a set of computer-executable instructions executed by a computer system and encoded or stored on a computer readable medium. Hereinafter, the method **3000** shall be explained with reference to the systems, components, modules, software, data structures, user interfaces, etc. described in conjunction with FIGS. **1-29**.

[**0606**] The registration module **2104** of the traffic controller **8112** can send a registration request, in step **3008**. The registration module **2104** may receive a signal that the vehicle is entering a traffic control area **2020**. The area **2020** may be bounded by the extents of the signal from the receivers **2008**. Upon receiving and identifying that the traffic control signal is present, the registration module **2104**, of the traffic controller **8112**, may include one or more items of information in the registration data **2300** as a request to register with the traffic control system **2000**. For example, the registration module **2104** may send destination and position information along with a permanent car identifier **2304**, if available, to the registration module **2104** of the control server **2004**.

[**0607**] The registration module **2104** of the control server **2004** can receive the registration, in step **3012**. The registration module **2104** of the control server **2004** may then send a confirmation back to the traffic controller **8112**. The traffic controller **8112** registration module **2104** can receive the registration confirmation, in step **3016**.

[**0608**] Thereinafter, a traffic control module **2108** of the traffic controller **8112** may send travel information, such as, the destination and position of the automobile to the control server **2004**. This information may be received by the traffic control module **2108**, of the control server **2004**, in step **3020**. This information may then be processed to determine which type of traffic configuration the automobile should take.

[**0609**] Thus, the traffic control module **2108** of the control server **2004** can determine a control arrangement, in step **3024**. The control arrangement can include any information about which lane, speed, node, assignment, or any other type of data that may be needed by the vehicle to operate within the traffic control system **2000**. This information may be then sent, as a control message by the message communication module **2112**, in step **3028**. The message may be received by the message communication module **2112**, of the traffic controller **8112**, in step **3032**. The information can include the information as shown in FIG. **23**. Upon receiving this information, the traffic control module **2108**, of the traffic controller, can generate a route to conform to the information provided by the control server **2004**, in step **3036**. This route may be as explained in conjunction with the navigation systems of the car. The car may then follow this route automatically by driving itself, in step **3040**.

[**0610**] Another method **3100** for requesting a registration for a traffic control system **2000** as shown in FIG. **31**. A general order for the steps of the method **3100** is shown in FIG. **31**. Generally, the method **3100** starts with a start operation **3104** and ends with an end operation **3132**. The method **3100** can include more or fewer steps or can arrange the order of the steps differently than those shown in FIG. **31**. The method **3100** can be executed as a set of computer-executable instructions executed by a computer system and encoded or stored on a computer readable medium. Hereinafter, the method **3100** shall be explained with reference to the systems, components, modules, software, data structures, user interfaces, etc. described in conjunction with FIGS. **1-30**.

[0611] A registration module 2104 may receive a signal from the message communication module 2112 that the vehicle has entered a traffic control system area 2020. The registration module 2104 of the traffic controller 8112 can form a registration request that may include information about the vehicle, such as, the car ID 2304 and one or more of the destination 2308 and position 2312. This information may be formed into a message to request registration and may be sent to the message communication module 2112 of the traffic controller 8112. This message may then be sent to the control server 2004 where the message communication module 2112 of the control server 2004 can receive the request, in step 3112. The message may be passed to the registration module 2104 of the control server 2004.

[0612] The registration module 2104 may then assign an ID 2304, if not already assigned, and may also generate any other information, as described in conjunction with FIG. 23, in step 3116. The registration module 2104 may also then provide direction for the automobile, such as, any information in the entry/exit field 2332 in the position field 2348 or any other information, in step 3120. This message may then be provided to the message communication module 2112 to be sent to the traffic controller 8112.

[0613] A message communication module 2112 of the traffic controller 8112 may then receive the directions, in step 3124. This information may then be extracted from the received message and provided to the traffic control module 2108. From the information in the message, the traffic control module 2108 can form a route to travel along based on the directions of the traffic control system 2000, in step 3128.

[0614] An embodiment of the message communication process 3200 may be as shown in FIG. 32. A general order for the steps of the method 3200 is shown in FIG. 32. Generally, the method 3200 starts with a start operation 3204 and ends with an end operation 3256. The method 3200 can include more or fewer steps or can arrange the order of the steps differently than those shown in FIG. 32. The method 3200 can be executed as a set of computer-executable instructions executed by a computer system and encoded or stored on a computer readable medium. Hereinafter, the method 3200 shall be explained with reference to the systems, components, modules, software, data structures, user interfaces, etc. described in conjunction with FIGS. 1-31.

[0615] After registration, the traffic control module 2108 can compose a message with the desired route for the vehicle. This information may include the destination 2308 and other information, as described in the registration queue data in FIG. 23. This message may be sent to the message communication module 2112 of the traffic controller 8112 and then sent to the control server 2004, in step 3208. The message communication module 2112a of the control server 2004 may receive the route information, in step 3212.

[0616] From this information, the traffic controller 2108 can determine one or more travel parameters for the vehicle, in step 3216. These travel parameters can include what destination and speed may be required by the vehicle. This information may then provide for determining how much information may be needed by the traffic controller 8112 to automatically control the vehicle within the traffic control area 2012. As such, the traffic control module 2108 can determine if a passive message is necessary, in step 3220. A passive message, as described in conjunction with FIG. 25, requires less data as the car may be more capable of controlling itself in the traffic control system 2000. If an active message is

necessary, the method 3200 proceeds NO to step 3224. However, if a passive message is possible, the method 3200 proceeds YES to step 3228.

[0617] In step 3224, the traffic control module 2108 can form an active message. The active message may be as described in conjunction with FIG. 26. If a passive message is necessary, the traffic control module 2108 can form the passive message, in step 3228. The passive message may be as described in conjunction with FIG. 25.

[0618] The traffic control module 2108 may then send a message to the message communication module 2112, which then sends the message to the traffic controller 8112, in step 3232. The traffic controller 8112 may then receive the message, in step 3236.

[0619] The information from the received message may be passed from the message communication module 2112 to the traffic control module 2108. The traffic control module 2108 may then detect if the message received is a passive message, in step 3240. Here, the traffic control module 2108 may determine the amount of data received or may look for a field within the message that denotes that the message is a passive message. If the message is passive, the method 3200 proceeds YES to step 3244. If the message is an active message, the method proceeds NO to step 3248.

[0620] In step 3244, the traffic control module 2108 may then establish control, in step 3244. Here, the traffic control module 2108 may determine one or more of the factors for driving the route, as may be described in FIG. 23. In other words, the traffic control module 2108 may generate the needed information not provided in the passive message 2500. This control, once established, allows the car to automatically drive the route.

[0621] In step 3248, the traffic control module 2108 forms the route from the message information. Thus, the traffic controller 8112 can pass on any information to a navigation system 336 to determine which route and where the car should be operated. The car may then travel the route automatically, in step 3252.

[0622] An embodiment of communicating a burst message is described in conjunction with FIG. 33. A general order for the steps of the method 3300 is shown in FIG. 33. Generally, the method 3300 starts with a start operation 3304 and ends with an end operation 3320. The method 3300 can include more or fewer steps or can arrange the order of the steps differently than those shown in FIG. 33. The method 3300 can be executed as a set of computer-executable instructions executed by a computer system and encoded or stored on a computer readable medium. Hereinafter, the method 3300 shall be explained with reference to the systems, components, modules, software, data structures, user interfaces, etc. described in conjunction with FIGS. 1-32.

[0623] The accident reporting and control module 2120 or traffic control module 2108 may determine if a burst message is needed, in step 3308. A burst message is generally provided to the vehicles in the traffic control system 2000 when there is an accident or a hazard in the road that at least some of the cars need to be rerouted to avoid. To accomplish this "reroute" of the two or more cars simultaneously or near simultaneously, the traffic control system 2000 uses a burst message that can be received by multiple vehicles substantially at the same time. If a burst message is needed, the method proceeds to YES to step 3312. However, if no burst message is needed, the method proceeds NO to end step 3320.

[0624] In step 3312, the traffic control module 2108 or accident reporting and control module 2120 may form the general message, as described in conjunction with FIG. 27. The message 2700 may provide information for how two or more cars may change their travel route to avoid the accident or obstruction. This information may then be sent to the message control module 2112, which can send the burst message either separately to two or more cars or broadcasts the message, in step 3316. The broadcast message may be sent generally and received and understood by two or more cars.

[0625] Embodiments of methods for communicating with or between two conveyances in the traffic control system 2000 or between a conveyance and a network are described in conjunction with FIGS. 34A and 34B. A general order for the steps of the method 3400 is shown in FIG. 34. Generally, the method 3400 starts with a start operation 3404, 3452 and ends with an end operation 3444, 3472. The method 3400 can include more or fewer steps or can arrange the order of the steps differently than those shown in FIG. 34. The method 3400 can be executed as a set of computer-executable instructions executed by a computer system and encoded or stored on a computer readable medium. Hereinafter, the method 3400 shall be explained with reference to the systems, components, modules, software, data structures, user interfaces, etc. described in conjunction with FIGS. 1-33.

[0626] One or more modules may determine if a message is required, in step 3408. The one or more modules may then compose a message and send the message to the message communication module 2112 of the traffic controller 8112.

[0627] The message communication module 2112 may then determine if the message is bound for the traffic control network 2000, in step 3412. The message may have an ID or a destination address that designates whether or not the message is meant for the network 2000. If the message is meant for the network 2000, then the method 3400 proceeds YES to step 3432. If the message is not destined for the network 2000, then method 3400 proceeds NO to step 3416.

[0628] In step 3416, the message communication module 2112 may then determine if the message is destined for another conveyance or car. Again, the message communication module 2112 can determine if an address is provided for another car, such as, a controller ID 2320 that designates that the message is meant for another conveyance. If the message is meant for another car, the method 3400 proceeds YES to step 3420. If the message is not destined for a car, then method 3400 proceeds NO to step 3418 where the message communication module may respond to the other module forming the message to require further definition.

[0629] In step 3420, the message communication module 2112 may extract information to determine which car is to receive the message. Here, the message communication module 2112 can extract the node controller ID 2320 or other car ID 2304 from the message. From that information, the message communication module 2112 can form the message, in step 3424, and send the message to the other car by transmitting that message over a wireless link, in step 3428.

[0630] In step 3432 the message communication module 2112 can form a message destined for the network 2000. The message may incorporate any type of file wrapper or necessary types of communication protocol information for communicating with the network 2000. The message communication module 2112 may then send the message to the network 2000, in step 3436. At this point, the message communication module 2112 may determine if a confirmation

that the message was received is obtained, in step 3440. Here, the message communication module 2112 may wait a period of time to determine if a confirmation message has been sent. If no confirmation message has been sent, the method may proceed NO to step 3428 or to step 3436 to resend the message. However, if a confirmation message has been received, the method 3400 proceeds to YES to end step 3444.

[0631] In method 3448, the message communication module 2112 may receive a message, in step 3456. Here, the message communication module 2112 may receive a message from either the network or another car, and need to determine the origin of the message, in step 3460. The message may have an originator ID or some other information or may be received over a specific type of network or by a certain protocol, which will indicate where the message was originated. If the message is from the car, the method 3448 proceeds YES to step 3468. If the message is not from a car, the method proceeds NO to step 3464.

[0632] In step 3464, the message communication module 2112 can form a confirmation message to send to the network. In this way, the message communication module 2112 provides information as to whether the message was received. Similarly, in step 3468, the message communication module 2112 can send a confirmation message to another automobile to confirm receipt of the message.

[0633] An embodiment of a method 3500 for completing a zone hand-off is shown in FIG. 35. A general order for the steps of the method 3500 is shown in FIG. 35. Generally, the method 3500 starts with a start operation 3504 and ends with an end operation 3528. The method 3500 can include more or fewer steps or can arrange the order of the steps differently than those shown in FIG. 35. The method 3500 can be executed as a set of computer-executable instructions executed by a computer system and encoded or stored on a computer readable medium. Hereinafter, the method 3500 shall be explained with reference to the systems, components, modules, software, data structures, user interfaces, etc. described in conjunction with FIGS. 1-34.

[0634] A traffic control module 2108, of the control server 2004, or the traffic controller 8112, can determine if the vehicle is leaving a zone 2008, in step 3508. If the vehicle is not leaving a zone 2016, the method 3500 can proceed NO to wait a period of time before determining again if the vehicle is leaving the zone 2016. To determine if a vehicle is leaving a zone 2016, the traffic control module 2108 may compare the current position 2312 to the extents of the zone 2008. The extents may be predefined and provided to the traffic control module 2108. In other situations, traffic control module 2108 may analyze the signal strength of the received signal at the transceiver 2008 to determine if that signal is starting to degrade. If the vehicle is nearing the extents of the zone 2016, the traffic control module 2108 may determine that the vehicle is leaving the zone 2016, and the method 3500 proceeds YES to step 3512.

[0635] In step 3512, the traffic control module 2108 may determine the next zone 2016 to which the vehicle is entering. Here, the traffic control module 2108 of the traffic controller may determine another signal that is increasing in strength or viability. In another situation, the current controller 2004 may present, provide information to the traffic control module 2108 that provides a designation as to which is the next control server 2004 to contact. This information may be provided in a handoff message 2800, as described in conjunction with FIG. 28.

[0636] The first control server 2004 may then pass control of the vehicle to the next zone's control server 2004. On passing this information, the information for the vehicle may be placed into the next queue 2136 associated with that control server 2004. As such, the information is passed to the next zones queue, in step 3516, and the second control server 2104 may contact the traffic controller 8112 to establish communications for that zone 2016.

[0637] In step 3520, the traffic control module 2108 at the control server 2004, establishes communications with the traffic controller 8112 to provide information about communicating with that control server 2004. The control server 2004 may provide the handoff message 2800 to establish communications. The message communication module 2112 may then wait for a confirmation from the traffic controller 8112. If a confirmation message is sent from the traffic controller 8112 to the message communication module 2112, the method 3500 proceeds YES to end step 3528. However, if no confirmation message is received, the method 3500 proceeds NO to step 3520 to establish communications again.

[0638] An embodiment of method 3600 to establish two or more zones 2016 in a traffic control area 2020 is shown in FIG. 36. A general order for the steps of the method 3600 is shown in FIG. 36. Generally, the method 3600 starts with a start operation 3604 and ends with an end operation 3628. The method 3600 can include more or fewer steps or can arrange the order of the steps differently than those shown in FIG. 36. The method 3600 can be executed as a set of computer-executable instructions executed by a computer system and encoded or stored on a computer readable medium. Hereinafter, the method 3600 shall be explained with reference to the systems, components, modules, software, data structures, user interfaces, etc. described in conjunction with FIGS. 1-35.

[0639] Here, two or more controllers 2004 may communicate to establish coverage over a roadway 2012, in step 3608. The antennas 2008 may be positioned to create two or more zones 2016 that overlap on at least a portion of the roadway 2012.

[0640] Once coverage is established, it is determined how much of the area of the road is covered, in step 3612. Here, the area for each zone 2016 and the total area covered may be determined. This area may include determining or testing the distance of the signals and any possible overlap of those signals to determine the extents of the zones 2016. Once the area of one zone 2016 is determined, the next area for the next zone 2016 may be determined, in step 3616. Here, the control server 2004 can determine where the two zones 2016 overlap. This overlapping area may be minimized to establish a more clear boundary for the two zones 2016. Further, the delineation between the two zones 2016 may also be defined between or in the area that includes the signal overlap.

[0641] The control server 2004 may then establish the boundary between the two zones 2016 and determine any boundary conditions for any handoffs, in step 3620. The boundary condition(s) can be at which point that the handoffs should occur. As such, a handoff message or contact with a traffic controller 8112 will happen based on the boundary condition. Further, any kind of communication conditions between two or more control servers 2004 may be established to ensure proper handoff of traffic in the traffic control system 2000.

[0642] An embodiment of a method 3700 to react to an emergency situation is shown in FIG. 37. A general order for

the steps of the method 3700 is shown in FIG. 37. Generally, the method 3700 starts with a start operation 3704 and ends with an end operation 3736. The method 3700 can include more or fewer steps or can arrange the order of the steps differently than those shown in FIG. 37. The method 3700 can be executed as a set of computer-executable instructions executed by a computer system and encoded or stored on a computer readable medium. Hereinafter, the method 3700 shall be explained with reference to the systems, components, modules, software, data structures, user interfaces, etc. described in conjunction with FIGS. 1-28.

[0643] A traffic controller 8112 may receive information that indicates an emergency on the traffic roadway 2012. The accident control module 2120 can receive an indication of sudden braking, steering, or other information from one or more of the navigation systems 336. Any type of sudden or unplanned movement, stoppage, acceleration, or other process of the vehicle, can indicate the emergency action, in step 3708.

[0644] If an emergency action is indicated and detected by the accident control module 2120, the accident control module 2120 can create a notification, in step 3712. The notification defines a position of the emergency and any emergency action that was completed to provide information to the control server 2004 about where the emergency may be located and how the control server 2004 may react to that emergency. The accident control module 2120 can then pass this message notification to the message communication module 2112 to send a notification, in step 3716.

[0645] The message control module 2112 can receive the notification, in step 3720. The message may then be passed to the accident reporting and control module 2120 of the control server 2004. The accident reporting control module 2120 can receive two or more of the emergency messages from two or more conveyances, each responding to the accident.

[0646] From the information reported by the one or more conveyances, the accident reporting and control module 2120 can determine if there is a need to change the travel routes of one or more vehicles that are approaching the scene of the accident or emergency, in step 3724. If a change in the travel route is required, the method 3700 proceeds YES to step 3732. However, if no change is necessary, as the accident or emergency was temporary and has already been addressed, then method 3700 proceeds NO to step 3728. In step 3728, all the routes are maintained without any interaction with the control server 2004.

[0647] In step 3732, the accident reporting control module 2120 can determine how to adjust the routes of the one or more approaching conveyances and provide that information to the traffic controller 2108. For example, the accident reporting control module 2120 can determine the accident occurred in the third lane at a specific mile marker position in the roadway 2012. With the information, the traffic control module 2108 can determine ETA estimates for any vehicle that is approaching the accident, for example, cars that are driving in the third line and approaching the mile marker of the accident. The traffic control module 2108 may then determine how to adjust the routes for these approaching vehicles and may include that information in a message, such as a burst message 2700. These adjusted routes may be received by the traffic controllers 8210, which can react to evade or reroute around the accident.

[0648] An embodiment of a method 3800 to determine if an accident has occurred may be shown in FIG. 38. A general

order for the steps of the method **3800** is shown in FIG. **38**. Generally, the method **3800** starts with a start operation **3804** and ends with an end operation **3836**. The method **3800** can include more or fewer steps or can arrange the order of the steps differently than those shown in FIG. **38**. The method **3800** can be executed as a set of computer-executable instructions executed by a computer system and encoded or stored on a computer readable medium. Hereinafter, the method **3800** shall be explained with reference to the systems, components, modules, software, data structures, user interfaces, etc. described in conjunction with FIGS. **1-28**.

[**0649**] Here, an accident control module **2120**, of the traffic controller **8112**, can sense an anomaly in the route progression of the automobile or conveyance. An anomaly occurs when the conveyance deviates from the planned route or deviates from other control information as described in FIG. **23**. If an anomaly occurs, the accident control module **2120** can report the anomaly, in step **3812**. Here, a notification may be composed by the accident control module **2120** and sent through the message communication module **2012** to the control server **2004**.

[**0650**] The control server **2004** can receive the anomaly information, in step **3816**. Here, the notification message is from two or more conveyances and may be processed through the message communication module **2112** to the accident and control module **2120**. Using that information and any other information gathered, in step **3820**, the accident reporting and control module **2120** can determine if an accident or emergency has occurred, in step **3824**. Here, if two or more cars have deviated or had to react to something in the roadway **2120**, the accident reporting and control module **2120** can determine that there may be an accident or problem in the roadway that needs to be identified and reacted to. If an accident or emergency is determined, the method **3800** proceeds YES to step **3828**. However, if no emergency or accident has currently been determined, the method **3800** proceeds NO to continue to monitor the situation, in step **3832**.

[**0651**] In step **3828**, the accident reporting and control module **2120** can then send an emergency alert to one or more conveyances through the message communication module **2112**. The alert may simply give the conveyance information of the location of the alert or what may need to be done, such as, providing a burst message or other type of message **2500**, **2600**, **2700**.

[**0652**] An embodiment of a method for failing over control servers **2004** is shown in FIG. **39**. A general order for the steps of the method **3900** is shown in FIG. **39**. Generally, the method **3900** starts with a start operation **3904** and ends with an end operation **3944**. The method **3900** can include more or fewer steps or can arrange the order of the steps differently than those shown in FIG. **39**. The method **3900** can be executed as a set of computer-executable instructions executed by a computer system and encoded or stored on a computer readable medium. Hereinafter, the method **3900** shall be explained with reference to the systems, components, modules, software, data structures, user interfaces, etc. described in conjunction with FIGS. **1-28**.

[**0653**] A traffic control module **2108** of a control server **2004** can create a queue, in step **3908**. A queue may be stored in the queues database **2136**. As described in conjunction with FIG. **23**, the queue can have information for one or more cars that are being controlled by the control server **2004** in the zone **2016**.

[**0654**] To ensure redundancy of the system **2000** between control servers **2004**, each control server can communicate with one or more other control servers **2004**. For example, control server **2004A** can communicate with control server **2004B** and control server **2004C**. The communications between these different control servers **2004** provide information about the automobiles that that control server **2004** is currently communicating with. Further, the control servers **2004** can communicate with several transceivers **2008** for several zones **2016**. As such, each control server **2004** is capable of controlling the queues in two or more zones **2016**.

[**0655**] A first control server **2004A** can provide the queue that was created by that control server **2004A** to another control server **2004B**, in step **3912**. The queue may be copied from the queue database **2136** and provided to the second control server **2004B**. The redundancy module **2124** of the control server **2004B** can store the queue in its own queue database **2136**. The queue database **2136** for the active queue for the control server **2004** may be stored separately from the queue from another control server **2004B** that is a redundant queue in the queue database **2136**. Thus, the second control server **2004B** can duplicate the queue, in step **3916**.

[**0656**] At some point thereafter, the first control server **2004A** can have a fail event, in step **3924**. The fail event can be any type of occurrence that causes the control server **2004A** to stop functioning, at least temporarily. For example, a fail event can be a power loss, can be a hardware failure, or can be some other type of catastrophic or temporary issue with the control server **2004A** and its function.

[**0657**] The second control server **2004B** can detect a failure of the first control server **2004A** in step **3920**. To detect a failure, the second control server **2004B** may stop receiving signals from the first control server **2004A**, can stop receiving some type of state of health message, may not receive a response to a ping or other query from the second control server **2004B**, or can receive a message from another control server, for example, control server **2004C** that describes or indicates that the first control server **2004A** has failed.

[**0658**] Upon detecting the failure, the second control server **2004B** assumes the queue, in step **3928**. The control server **2004B** may then begin to manage the redundant queue in the queues database **2136** that was provided from the first control server **2004A**. The redundant queue becomes an active queue for the second control server **2004B**. Further, the second control server **2004B** can establish communications with the one or more automobiles within the queue to provide further instruction or be able to instruct the automobiles or conveyances in the future. Thereinafter, the second control server **2004B** acts as the control server for the zone **2016A** similar to its function as the control server for the second zone **2016B**.

[**0659**] At some time thereafter, the first control server **2004A** may recover from the fail event, in step **3936**. The first control server **2004A** may be repaired, may be brought back up online, or may be replaced. This recovery causes communications to begin again with the second control server **2004B** or one or more control servers **2004C**.

[**0660**] The second control server **2004B** can detect the recovery, in step **3932**. Upon detecting the recovery, the second control server **2004B** provides the information from the queue that was assumed by that second control server **2004B**. The first control server **2004A** may then assume the queue again, in step **3940**. The changing over of the queue control from the second control server **2004B** to the first control server **2004A** is similar to the method and processes

described in conjunction with step 3928. Thereinafter, the first control server 2004A functions normally to control the queue for the first zone 2016a.

[0661] An embodiment for a method for consolidating traffic based on routes similarities as shown in FIG. 40. A general order for the steps of the method 4000 is shown in FIG. 40. Generally, the method 4000 starts with a start operation 4004 and ends with an end operation 4032. The method 4000 can include more or fewer steps or can arrange the order of the steps differently than those shown in FIG. 40. The method 4000 can be executed as a set of computer-executable instructions executed by a computer system and encoded or stored on a computer readable medium. Hereinafter, the method 4000 shall be explained with reference to the systems, components, modules, software, data structures, user interfaces, etc. described in conjunction with FIGS. 1-28.

[0662] The traffic control module 2108, of the control server 2004, can receive a travel request from a traffic controller 8112, in step 4008. The travel request can include any of the information, as described in conjunction with FIG. 23. The travel request can at least provide a destination for the automobile that is associated with the traffic controller 8112. The traffic controller 2108 may then analyze the traffic request, in step 4012. The analysis of the travel request can include determining the destination or other information from the travel request that may have a similarity to one or more other conveyances on the road 2012.

[0663] The traffic control module 2108 may then compare any of the analyzed parts of the travel request with one or more other travel requests received before or after from other vehicles. The other travel requests may be stored within the queues database 2136. The other travel requests may be associated with conveyances or automobiles that are within spatial proximity to the automobile associated with the traffic controller 8112. For example, a spatial proximity of a hundred yards or less may be appropriate for determining similarities between travel requests. Thus, the traffic control module 2108 may then determine if there are similarities between two or more travel requests, in step 4016. The similarities may be commonalities between any of the information contained in the travel request, as shown in FIG. 23. For example, the traffic control module 2108 may determine if two or more conveyances have a similar destination 2308 in their travel requests.

[0664] If there are two or more travel requests with at least one similarity that ensures that these conveyances may proceed along the roadway 2112 in a similar manner, the traffic control module 2108 can determine that the two or more conveyances have similar routes, in step 4020. The identification of similar routes ensures that the traffic control module 2108 can merge those two or more conveyances together into a similar portion of the roadway 2012 such that those automobiles will enter or, at least, exit 2012 in similar places. This consolidation allows traffic to be changed between lanes such that conveyances with destinations that are further along the roadway 2012 are merged into a further left hand lane (in the United States) or further right hand lane (in Britain) because those automobiles will travel farther on the roadway and past more exits. The automobiles that have exits that are nearer to the current position of those automobiles will remain in the lanes closer to the exits as they are going to exit more quickly.

[0665] The traffic control module 2108 may then issue or create instructions for the two or more conveyances such that their routes are similar and parallel to each other, in step 4024.

These instructions may also provide for merging the traffic together into closer spatial proximity. These instructions may then be sent to the conveyances, through the message communication module 2112, in step 4028. Upon receiving the instructions, the traffic controllers 8112 can send information, through the traffic control module 2108 to control the car and bring the car in closer spatial proximity to the other conveyances with similar routes.

[0666] An embodiment of creating a node for two or more conveyances on the roadway 2012 is shown in FIG. 41. A general order for the steps of the method 4100 is shown in FIG. 41. Generally, the method 4100 starts with a start operation 4104 and ends with an end operation 4140. The method 4100 can include more or fewer steps or can arrange the order of the steps differently than those shown in FIG. 41. The method 4100 can be executed as a set of computer-executable instructions executed by a computer system and encoded or stored on a computer readable medium. Hereinafter, the method 4100 shall be explained with reference to the systems, components, modules, software, data structures, user interfaces, etc. described in conjunction with FIGS. 1-28.

[0667] A message communication module 2112 can receive node information from the message communication module 2112, of the control server 2004, in step 4108. The node information may be any information that is as described in conjunction with FIG. 24. This information may be stored in the database 2208 for the traffic controller 8112. The information may then be sent to the node formation module 2116.

[0668] The node formation module 2116 may then detect or determine the node controller, from the node information, described in conjunction with FIG. 24, in step 412. For example, the node formation module 2116 may extract the node controller ID 2412 from the node information 2400.

[0669] The node formation module 2116 may then send a node join request, in step 4116. Here, the node formation module 2116 can indicate that the message being sent is a node formation or a node join request, in node request field 2420. Information, including the car ID 2404 or other information, may be inserted into the message. This information may then be sent to the message communication module 2112 to be broadcast or sent to the node controller of the node. Thus, the message communication module 2112 sends the message, in step 4116.

[0670] The conveyance acting as the node controller can receive the node request, in step 4120. Here, the message communication module 2112 of the receiving conveyance or traffic controller 8112 can receive the node request. The node formation module 2116 of the receiving node can extract any information from the request message and then create other node information, in step 4124. Here, the node formation module 2116 can extract other information about the node from node database 2208. This information may then be inserted in a response message similar to that shown in FIG. 24. The response message may indicate that it is a response message in field 2420. The node formation module 2116 may then send that response message to the message communication module 2112, in step 4128.

[0671] The conveyance can receive the node response, in step 4132. Here, the response message provides the information needed to join the node. This information may then be stored, by the node formation module 2116, in the node database 2208. Thereinafter, the conveyance is part of the node and will listen to instructions from the node controller. The node formation module 2116 waits for instructions from

the node controller, in step **4136**. As such, the control servers **2004** need only communicate with the node controller to cause traffic to change. The node controllers may then send any required information on to the other members of the node that are waiting for instruction. Those other conveyances will receive instructions through the message communication module **2112** to be sent to the traffic control module **2108**. This information may then be used to control the vehicle. In this way, two or more conveyances may be controlled simultaneously as a single unit by controlling a node instead of individual automobiles.

[0672] An embodiment of a method for creating advertising for conveyances having similarities is shown in FIG. **42**.

[0673] The advertising module **2132** of the control server **2004** can receive node information, from the node formation module **2116**, in step **4208**. Here, the node information may be as shown in node information **2400** of FIG. **24**. This information may allow the advertising module **2132** to extract car identifiers **2408** or other information about the automobiles. This node information may then allow the advertising module **2132** to identify drivers or passengers that are associated with those cars based on consumer data **2140**. The consumer data **2140** can include information about the automobiles, the drivers, and passengers typically associated with those automobiles, and any type of consumer information that may have been provided or detected from profile information **1238**. As such, the advertising module **2132** can receive consumer information for each of the node members, in step **4212**.

[0674] From the consumer information, the advertising module **2132** can determine similarities between consumer habits of the node members, in step **4216**. Here, the similarities can be types of goods or services purchased in the past, can be similar types of interests or hobbies, can be similar routes driven, or other information. These similarities can be determined by one or more different algorithms that match similarities among different people.

[0675] The advertising module **2132** may then match one or more types of advertising to the similarities, in step **4220**. If the advertising module **2120** determines a similar good associated with two or more (or possibility a majority of the members of the node), the advertising module **2120** can extract advertising that is directed to that similar interest. For example, if several members of the node drink Starbucks Coffee, the advertising module **2132** can extract advertising that is directed to Starbucks Coffee. This information may then be used to create advertising for the nodes.

[0676] In step **4224**, the advertising module **2132** can create the advertising or obtain the advertising for a billboard or other signage near the roadway for the passing node. As the members of the node are in spatial proximity, advertising may be directed to those different node members when the node itself, with its several members, passes a particular point on the roadway **2012**. For example, if there is a billboard at mile marker **22**, the billboard may be electronic and may be able to be changed automatically as the first or at least several of the node members near the mile marker **22**. Thus, the advertising module **2132** can individualize or direct advertising specifically to members of a node. This advertising may then be sent to the billboard or other automated signage to change its display. In this way the advertising module **2132** ensures more directed and better received advertising based on node

characteristics rather than individuals. The ads may be presented, in step **4228**, to the node members on the signage or roadside displays.

[0677] In other situations, the ads presented may be sent for display on a user interface **248** inside of the conveyance. As such, the advertising module **2132** can send an advertising message to the message communication module **2112** directed to the traffic controller **8112**. This message may then be sent through the consumer module **2204** to instruct a display on a user interface that creates an ad. These ads may display on a non-obtrusive portion of the automobile or for one or more passengers within the car. This information then may be common amongst at least two or more members of the node and be better received as those node members have similar consumer habits. These ads can be directed through a node controller, as described in conjunction with FIG. **41**.

[0678] The exemplary systems and methods of this disclosure have been described in relation to configurable vehicle consoles and associated devices. However, to avoid unnecessarily obscuring the present disclosure, the preceding description omits a number of known structures and devices. This omission is not to be construed as a limitation of the scopes of the claims. Specific details are set forth to provide an understanding of the present disclosure. It should however be appreciated that the present disclosure may be practiced in a variety of ways beyond the specific detail set forth herein.

[0679] Furthermore, while the exemplary aspects, embodiments, options, and/or configurations illustrated herein show the various components of the system collocated, certain components of the system can be located remotely, at distant portions of a distributed network, such as a LAN and/or the Internet, or within a dedicated system. Thus, it should be appreciated, that the components of the system can be combined in to one or more devices, such as a Personal Computer (PC), laptop, netbook, smart phone, Personal Digital Assistant (PDA), tablet, etc., or collocated on a particular node of a distributed network, such as an analog and/or digital telecommunications network, a packet-switch network, or a circuit-switched network. It will be appreciated from the preceding description, and for reasons of computational efficiency, that the components of the system can be arranged at any location within a distributed network of components without affecting the operation of the system. For example, the various components can be located in a switch such as a PBX and media server, gateway, in one or more communications devices, at one or more users' premises, or some combination thereof. Similarly, one or more functional portions of the system could be distributed between a telecommunications device(s) and an associated computing device.

[0680] Furthermore, it should be appreciated that the various links connecting the elements can be wired or wireless links, or any combination thereof, or any other known or later developed element(s) that is capable of supplying and/or communicating data to and from the connected elements. These wired or wireless links can also be secure links and may be capable of communicating encrypted information. Transmission media used as links, for example, can be any suitable carrier for electrical signals, including coaxial cables, copper wire and fiber optics, and may take the form of acoustic or light waves, such as those generated during radio-wave and infra-red data communications.

[0681] Also, while the flowcharts have been discussed and illustrated in relation to a particular sequence of events, it should be appreciated that changes, additions, and omissions

to this sequence can occur without materially affecting the operation of the disclosed embodiments, configuration, and aspects.

[0682] A number of variations and modifications of the disclosure can be used. It would be possible to provide for some features of the disclosure without providing others.

[0683] It should be appreciated that the various processing modules (e.g., processors, vehicle systems, vehicle subsystems, modules, etc.), for example, can perform, monitor, and/or control critical and non-critical tasks, functions, and operations, such as interaction with and/or monitoring and/or control of critical and non-critical on board sensors and vehicle operations (e.g., engine, transmission, throttle, brake power assist/brake lock-up, electronic suspension, traction and stability control, parallel parking assistance, occupant protection systems, power steering assistance, self-diagnostics, event data recorders, steer-by-wire and/or brake-by-wire operations, vehicle-to-vehicle interactions, vehicle-to-infrastructure interactions, partial and/or full automation, telematics, navigation/SPS, multimedia systems, audio systems, rear seat entertainment systems, game consoles, tuners (SDR), heads-up display, night vision, lane departure warning, adaptive cruise control, adaptive headlights, collision warning, blind spot sensors, park/reverse assistance, tire pressure monitoring, traffic signal recognition, vehicle tracking (e.g., LoJack™), dashboard/instrument cluster, lights, seats, climate control, voice recognition, remote keyless entry, security alarm systems, and wiper/window control). Processing modules can be enclosed in an advanced EMI-shielded enclosure containing multiple expansion modules. Processing modules can have a “black box” or flight data recorder technology, containing an event (or driving history) recorder (containing operational information collected from vehicle on board sensors and provided by nearby or roadside signal transmitters), a crash survivable memory unit, an integrated controller and circuitry board, and network interfaces.

[0684] Critical system controller(s) can control, monitor, and/or operate critical systems. Critical systems may include one or more of (depending on the particular vehicle) monitoring, controlling, operating the ECU, TCU, door settings, window settings, blind spot monitor, monitoring, controlling, operating the safety equipment (e.g., airbag deployment control unit, collision sensor, nearby object sensing system, seat belt control unit, sensors for setting the seat belt, etc.), monitoring and/or controlling certain critical sensors such as the power source controller and energy output sensor, engine temperature, oil pressure sensing, hydraulic pressure sensors, sensors for headlight and other lights (e.g., emergency light, brake light, parking light, fog light, interior or passenger compartment light, and/or tail light state (on or off)), vehicle control system sensors, wireless network sensor (e.g., Wi-Fi and/or Bluetooth sensors, etc.), cellular data sensor, and/or steering/torque sensor, controlling the operation of the engine (e.g., ignition, etc.), head light control unit, power steering, display panel, switch state control unit, power control unit, and/or brake control unit, and/or issuing alerts to a user and/or remote monitoring entity of potential problems with a vehicle operation.

[0685] Non-critical system controller(s) can control, monitor, and/or operate non-critical systems. Non-critical systems may include one or more of (depending on the particular vehicle) monitoring, controlling, operating a non-critical system, emissions control, seating system controller and sensor, infotainment/entertainment system, monitoring certain non-

critical sensors such as ambient (outdoor) weather readings (e.g., temperature, precipitation, wind speed, and the like), odometer reading sensor, trip mileage reading sensor, road condition sensors (e.g., wet, icy, etc.), radar transmitter/receiver output, brake wear sensor, oxygen sensor, ambient lighting sensor, vision system sensor, ranging sensor, parking sensor, heating, venting, and air conditioning (HVAC) system and sensor, water sensor, air-fuel ratio meter, hall effect sensor, microphone, radio frequency (RF) sensor, and/or infrared (IR) sensor.

[0686] It is an aspect of the present disclosure that one or more of the non-critical components and/or systems provided herein may become critical components and/or systems, and/or vice versa, depending on a context associated with the vehicle.

[0687] Optionally, the systems and methods of this disclosure can be implemented in conjunction with a special purpose computer, a programmed microprocessor or microcontroller and peripheral integrated circuit element(s), an ASIC or other integrated circuit, a digital signal processor, a hardwired electronic or logic circuit such as discrete element circuit, a programmable logic device or gate array such as PLD, PLA, FPGA, PAL, special purpose computer, any comparable means, or the like. In general, any device(s) or means capable of implementing the methodology illustrated herein can be used to implement the various aspects of this disclosure. Exemplary hardware that can be used for the disclosed embodiments, configurations and aspects includes computers, handheld devices, telephones (e.g., cellular, Internet enabled, digital, analog, hybrids, and others), and other hardware known in the art. Some of these devices include processors (e.g., a single or multiple microprocessors), memory, nonvolatile storage, input devices, and output devices. Furthermore, alternative software implementations including, but not limited to, distributed processing or component/object distributed processing, parallel processing, or virtual machine processing can also be constructed to implement the methods described herein.

[0688] In yet another embodiment, the disclosed methods may be readily implemented in conjunction with software using object or object-oriented software development environments that provide portable source code that can be used on a variety of computer or workstation platforms. Alternatively, the disclosed system may be implemented partially or fully in hardware using standard logic circuits or VLSI design. Whether software or hardware is used to implement the systems in accordance with this disclosure is dependent on the speed and/or efficiency requirements of the system, the particular function, and the particular software or hardware systems or microprocessor or microcomputer systems being utilized.

[0689] In yet another embodiment, the disclosed methods may be partially implemented in software that can be stored on a storage medium, executed on programmed general-purpose computer with the cooperation of a controller and memory, a special purpose computer, a microprocessor, or the like. In these instances, the systems and methods of this disclosure can be implemented as program embedded on personal computer such as an applet, JAVA® or CGI script, as a resource residing on a server or computer workstation, as a routine embedded in a dedicated measurement system, system component, or the like. The system can also be implemented by physically incorporating the system and/or method into a software and/or hardware system.

[0690] Although the present disclosure describes components and functions implemented in the aspects, embodiments, and/or configurations with reference to particular standards and protocols, the aspects, embodiments, and/or configurations are not limited to such standards and protocols. Other similar standards and protocols not mentioned herein are in existence and are considered to be included in the present disclosure. Moreover, the standards and protocols mentioned herein and other similar standards and protocols not mentioned herein are periodically superseded by faster or more effective equivalents having essentially the same functions. Such replacement standards and protocols having the same functions are considered equivalents included in the present disclosure.

[0691] The present disclosure, in various aspects, embodiments, and/or configurations, includes components, methods, processes, systems and/or apparatus substantially as depicted and described herein, including various aspects, embodiments, configurations, subcombinations, and/or subsets thereof. Those of skill in the art will understand how to make and use the disclosed aspects, embodiments, and/or configurations after understanding the present disclosure. The present disclosure, in various aspects, embodiments, and/or configurations, includes providing devices and processes in the absence of items not depicted and/or described herein or in various aspects, embodiments, and/or configurations hereof, including in the absence of such items as may have been used in previous devices or processes, e.g., for improving performance, achieving ease and/or reducing cost of implementation.

[0692] The foregoing discussion has been presented for purposes of illustration and description. The foregoing is not intended to limit the disclosure to the form or forms disclosed herein. In the foregoing Detailed Description for example, various features of the disclosure are grouped together in one or more aspects, embodiments, and/or configurations for the purpose of streamlining the disclosure. The features of the aspects, embodiments, and/or configurations of the disclosure may be combined in alternate aspects, embodiments, and/or configurations other than those discussed above. This method of disclosure is not to be interpreted as reflecting an intention that the claims require more features than are expressly recited in each claim. Rather, as the following claims reflect, inventive aspects lie in less than all features of a single foregoing disclosed aspect, embodiment, and/or configuration. Thus, the following claims are hereby incorporated into this Detailed Description, with each claim standing on its own as a separate preferred embodiment of the disclosure.

[0693] Moreover, though the description has included description of one or more aspects, embodiments, and/or configurations and certain variations and modifications, other variations, combinations, and modifications are within the scope of the disclosure, e.g., as may be within the skill and knowledge of those in the art, after understanding the present disclosure. It is intended to obtain rights which include alternative aspects, embodiments, and/or configurations to the extent permitted, including alternate, interchangeable and/or equivalent structures, functions, ranges or steps to those claimed, whether or not such alternate, interchangeable and/or equivalent structures, functions, ranges or steps are disclosed herein, and without intending to publicly dedicate any patentable subject matter.

1-20. (canceled)

21. A method for providing navigation information for a control server, comprising:

a first control server, including a processor, controlling a vehicle in a traffic control system while the vehicle is in a first zone and determining that the vehicle is leaving the first zone;

the first control server determining a second zone to which the vehicle is entering;

the first control server determining a second control server associated with the second zone, wherein the second control server is configured to control the vehicle while the vehicle is in the second zone; and

the first control server passing control of the vehicle to the second control server associated with the second zone.

22. The method of claim **21**, wherein the second control server receives the vehicle into the second zone.

23. The method of claim **22**, wherein the first control server maintains the vehicle as an item in a first queue administered by the first control server.

24. The method of claim **23**, wherein, when the first control server passes control of the vehicle to the second control server associated with the second zone, the second control server accepts the vehicle as an item in a second queue administered by the second control server.

25. The method of claim **24**, further comprising:

the second control server establishing communication with the vehicle; and

the second control server determining if the vehicle has confirmed that communication has been established.

26. The method of claim **25**, further comprising, if the vehicle has not confirmed that communication has been established, the second control server re-establishing communication with the vehicle.

27. The method of claim **26**, wherein each zone is defined by an extents.

28. The method of claim **27**, wherein the extents are associated with a range of an antennae associated with each zone and in communication with the vehicle.

29. The method of claim **27**, wherein the extents are defined by two or more physical locations along a roadway.

30. The method of claim **29**, wherein the first control server passes control of the vehicle to the second control server associated with the second zone when a boundary condition is met that defines when to pass control of the vehicle.

31. A control server comprising:

a processor operable to execute one or more modules, the modules comprising:

a traffic control module operable to control a vehicle in a traffic control system while the vehicle is in a first zone and determine that the vehicle is leaving the first zone;

a zonal communication module operable to:

determine a second zone to which the vehicle is entering;

determine a second control server associated with the second zone, wherein the second control server is configured to control the vehicle while the vehicle is in the second zone; and

pass control of the vehicle to the second control server associated with the second zone.

32. The control server of claim **31**, wherein the control server maintains the vehicle as an item in a first queue admin-

istered by the control server, and wherein, when the control server passes control of the vehicle to the second control server associated with the second zone, the second control server accepts the vehicle as an item in a second queue administered by the second control server.

33. The control server of claim **32**, wherein a second traffic control module, associated with the second control server, is further operable to:

- establish communication with the vehicle; and
- determine if the vehicle has confirmed that communication has been established.

34. The control server of claim **33**, wherein the second traffic control module is further operable to, if the vehicle has not confirmed that communication has been established, re-establish communication with the vehicle.

35. The control server of claim **34**, wherein each zone is defined by an extents, wherein the extents are defined by one of a range of an antennae associated with each zone and in communication with the vehicle or by two or more physical locations along a roadway.

36. A non-transitory computer readable medium stored on a storage medium and having instructions that when executed by a processor cause the processor to perform a method, the instructions comprising:

- instructions to control, by a first control server, a vehicle in a traffic control system while the vehicle is in a first zone;
- instructions to determine that the vehicle is leaving the first zone;
- instructions to determine a second zone to which the vehicle is entering;

instructions to determine a second control server associated with the second zone, wherein the second control server is configured to control the vehicle while the vehicle is in the second zone; and

instructions to pass control of the vehicle from the first control server to the second control server associated with the second zone.

37. The computer readable medium of claim **36**, wherein the first control server maintains the vehicle as an item in a first queue administered by the first control server, and wherein, when the first control server passes control of the vehicle to the second control server associated with the second zone, the second control server accepts the vehicle as an item in a second queue administered by the second control server.

38. The computer readable medium of claim **37**, further comprising:

- instructions to establish communication with the vehicle; and
- instructions to determine if the vehicle has confirmed that communication has been established.

39. The computer readable medium of claim **38**, further comprising, if the vehicle has not confirmed that communication has been established, instructions to re-establish communication with the vehicle.

40. The computer readable medium of claim **39**, wherein each zone is defined by an extents, wherein the extents are defined by one of a range of an antennae associated with each zone and in communication with the vehicle or by two or more physical locations along a roadway.

* * * * *