

(19)



Europäisches Patentamt

European Patent Office

Office européen des brevets



(11)

EP 0 803 281 A1

(12)

EUROPEAN PATENT APPLICATION

(43) Date of publication:
29.10.1997 Bulletin 1997/44

(51) Int. Cl.⁶: B01D 63/02, B01D 65/00

(21) Application number: 97300119.1

(22) Date of filing: 09.01.1997

(84) Designated Contracting States:
DE GB

(30) Priority: 25.04.1996 JP 127665/96

(71) Applicant: KITZ CORPORATION
Chiba-shi, Chiba-ken (JP)

(72) Inventors:
• Watanabe, Masaharu,
c/o Kitz Corporation
Kitakoma-gun, Yamanashi-ken (JP)

• Suda, Eiji,
c/o Kitz Corporation
Kitakoma-gun, Yamanashi-ken (JP)

(74) Representative: Gordon, Michael Vincent
GILL JENNINGS & EVERY,
Broadgate House,
7 Eldon Street
London EC2M 7LH (GB)

(54) **Filter element**

(57) A filter element comprises:

a bundle of hollow fibre type separation membranes (1) made of a natural or synthetic macromolecular material, said bundle having an opening in at least one terminal part thereof; and a sealed part (2) made of a thermoplastic resin, bonded to said bundle at a temperature not higher than a melting or decomposing temperature of said

macromolecular material, and adapted to seal watertightly said opening of said bundle in a half-bonded state showing no compatibility with said macromolecular material and permitting persistence of a mutual interface of bondage.

FIG. 1

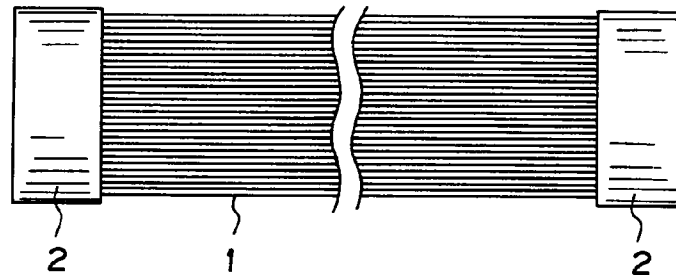

EP 0 803 281 A1

Description

This invention relates to a filter element for the treatment of a fluid by the use of a reverse osmosis membrane, an ultrafilter membrane, a precision filter membrane or a gas separation membrane as a separation membrane for various fluids which are used in various industries specializing in the manufacture of electronic products, foodstuffs, beverages, medicines, fermentation products, optical products, therapeutic products and precision products.

In the treatment of various fluids by the use of functional macromolecular membranes, represented by the separation membranes mentioned above, the functional macromolecular membranes are generally required to be modular units. The separation membranes are formed into flat plates, tubes, hollow fibres, etc. and their modular units have their shapes determined by the shape of a relevant separation membrane.

The modules of flat plate type separation membranes are disclosed in JP-UM-B-55-49076 and JP-P-B-63-28654, for example. The former module is in such a shape as is obtained by punching a disc out of a flat plate type separation membrane and setting the disc directly in place on a holder. The latter module is in such a shape as is obtained by similarly punching a disc, joining the disc along the circumference thereof to a support, thereby forming a unit, and superposing a plurality of such units. JP-P-A-60-58208 also discloses a module which is in such a shape as is obtained by pleating a flat plate type separation membrane, joining the opposite edges of the membrane when converting the membrane into a tubular membrane, and closing the opposite open ends of the tubular membrane with a sealing material.

The modules using hollow fibre type separation membranes (hereinafter referred to as "modules of filter element") are disclosed in JP-UM-A-05-56227 and JP-P-A-06-170179, for example. They are in such a shape as is obtained by bundling a plurality of hollow fibre type separation membranes and watertightly closing one open end or both open ends of the bundle with a sealing material. The modules of filter element of this type are allowed to assume a large available membrane surface per unit volume of module because they do not require any support for the membrane. Particularly, they are enabled to keep their inner surfaces of membrane clean because the inner surfaces are not exposed to the open air. They are also allowed to retain a high ability to clean the fluid under treatment by using their inner surfaces on the secondary side of fluid treatment. They further permit easy manufacture of cross flow type modules.

The modules of filter element possess various features besides those mentioned above as compared with the modules using the flat plate type and the tubular type separation membranes. In the manufacture thereof, the primary sides and the secondary sides thereof relative to the flow of the fluid under treatment must be watertightly isolated mutually in the open end parts of the bundle. For this purpose, the gaps between the adjacent hollow fibre type separation membranes must be sealed infallibly. This sealing has been hitherto attained generally by potting the gaps with such a potting material as polyurethane or epoxy resin which exhibits high flowability and, when mixed with other resin, manifests a hardening reaction. When the fluid subjected to the filtration is a higher active chemical substance such as acid or alkali, alcohol, ketone, ester, aromatic hydrocarbon, or chlorine type solvent and when such physical or mechanical working conditions as temperature and pressure are harsh, however, the modules are susceptible to physical and chemical invasion. When the potting material is improper or the bonding strength is weak, the sealed parts tend to sustain a crack or peel. The modules of filter element thus have the problem of limiting the range of application in terms of the kind of fluid subjected to the treatment and the condition of use because they are deficient in durability.

The modules of filter element proposed in JP-P-A-01-164405 and JP-P-A-01-281104 for the purpose of solving the problem mentioned above are such that the sealed parts are formed of a thermoplastic resin which is either identical to or compatible with the material for the hollow fibre type separation membranes. In this case, however, the hollow fibre type separation membranes in the sealed parts are thermally deteriorated or deprived of porosity to the extent of ultimately losing flexibility. To be specific, while the watertight contact between the hollow fibre type separation membranes and the sealed parts gains in thoroughness, the parts of the hollow fibre type separation membranes which are embedded in the sealed parts are embrittled to a point where they will be liable to succumb to chemical and physical invasion and sustain a crack. Further, as the sealed parts in the conventional modules have no room for absorbing expansion or contraction, they have the problem of sustaining a crack in the sealed parts themselves or in the hollow fibre type separation membranes.

This invention has been developed as a result of numerous diligent studies pursued with a view to overcoming the problems suffered by the prior art as described above. The object of this invention is to provide a filter element which is possessed of high durability to resist various chemical and physical invasion.

To accomplish the object mentioned above, the filter element of this invention comprises:

a bundle of hollow fibre type separation membranes made of a natural or synthetic macromolecular material, the bundle having an opening in at least one terminal part thereof; and

a sealed part made of a thermoplastic resin, bonded to the bundle at a temperature not higher than a melting or decomposing temperature of the macromolecular material, and adapted to seal watertightly the opening of the bundle in a half-bonded state showing no compatibility with the macromolecular material and permitting persistence of a mutual interface of bondage.

The invention will be better understood and objects, features and characteristics thereof, other than those set forth above will become apparent when consideration is given to the following detailed description thereof, which makes reference to the accompanying drawings, wherein:-

5 FIG. 1 is a schematic front view showing one example of a filter element according to this invention;
FIG. 2 is a schematic front view showing another example of a filter element according to this invention;
FIG. 3 is a photomicrograph showing the open terminal part of the filter element of FIG. 1 at x100 magnification;
FIG. 4 is a photomicrograph showing the open terminal part of the filter element of FIG. 1 at x200 magnification;
10 FIG. 5 is a half-cut cross section showing one example of a cartridge accommodating and protecting the filter element of FIG. 1;
FIG. 6 is a schematic front view of a device incorporating therein another example of a cartridge of the filter element according to this invention; and
FIG. 7 is a half-cut cross section showing one example of a module accommodating and protecting still another example of the filter element according to this invention.

15 The filter element contemplated by this invention, as shown in FIG. 1 or FIG. 2, comprises a plurality of hollow fibre type separation membranes 1 made of a macromolecular material and a sealed part 2 made of a thermoplastic resin for watertightly sealing the open terminal parts of the bundled hollow fibre type separation membranes 1 in a half-bonded state showing no compatibility with the macromolecular material and permitting persistence of the mutual inter-
20 face of bondage.

Appropriately, the hollow fibre type separation membranes 1 are such asymmetric hollow fibre type separation membranes as reverse osmosis membranes, ultrafilter membranes, or gas separation membranes which have a smooth skin layer on the inner surface thereof and a minutely jogging (non-smooth) support layer on the outer surface thereof. The separation membranes 1 appropriately have a microporous texture containing pores of a largest diameter
25 in the range of 0.01 to 5 μm . The material for the hollow fibre type separation membranes 1 is appropriately a flexible natural or synthetic macromolecular compound such as cellulose, cellulose ester, polysulfone, polyether sulfone, polypropylene, polyethylene, polyamide or polyacrylonitrile. It may be otherwise such an inorganic substance as metal, glass, or ceramic substance.

The material for the sealed part 2 appropriately is such a thermoplastic resin as exhibits perfect flowability at the melting temperature thereof. As concrete examples of the thermoplastic resin advantageously used herein, olefin type
30 resins such as polyethylene and polypropylene, copolymers of tetrafluoroethylene with polyfluoroalkyl ethers resembling in molecular structure to polyethylene and polypropylene (referred to hereinafter as "PFA"), and such fluorine type resins as polytetrafluoroethylene (referred to hereinafter as "PTFE") and fluorinated ethylene propylene (referred to hereinafter as "FEP") may be cited. It is essential that this material should possess a melting point lower than the melting or decomposing temperature of the material for the hollow fibre type separation membranes 1. Preferably, the difference between said temperatures of the two materials is not less than 20°C. The selection of the material for the sealed part 2 depends on the chemical properties of the fluid under treatment and the conditions of use thereof.

Generally, when two shaped articles using thermoplastic resins as raw materials and obtained by the method of forming such as injection moulding or extrusion moulding are thermally fused to each other, it is essential that their raw
40 materials should be compatible with each other. More often than not the asymmetric separation membranes such as reverse osmosis membranes or ultrafilter membranes which are possessed of a skin layer and a support layer have a relatively smooth skin layer on the inner surface thereof and nevertheless a minutely jogging support layer on the outer surface thereof. The microporous precision filter membranes similarly have a minutely jogging outer surface. These filter membranes, therefore, are capable of physically thorough watertight sealing owing to the anchor effect arising from
45 the entry of the fused member into the minutely jogging outer surface even in the absence of compatibility with the fused member.

In the open terminal parts of the bundled hollow fibre type separation membranes 1, by selectively melting the raw material for the sealed part 2 and consequently forming the sealed part 2 while permitting persistence of a definite inter-
50 face of bonding between the hollow fibre type separation membranes 1 and the sealed part 2 instead of using a thermoplastic resin identical to or compatible with the raw material for hollow fibre type separation membranes 1 and attaining thorough mutual fusion, therefore, the deterioration of the parts of the hollow fibre separation membranes 1 embedded in the sealed part 2 and the neighbourhood of the base of the sealed part 2 due to the influence of heat can be repressed to the smallest possible extent and, at the same time, the hollow fibre type separation membranes 1 can be made to keep the inherent flexibility intact. Thus, the produced filter element is strong enough to withstand chemical
55 and physical invasion and is capable of ensuring infallible bondage between the open terminal parts of the bundled hollow fibre separation membranes 1 and the sealed part 2.

The methods which are available for the formation of the sealed part 2 include (1) a method which comprises preparing paste by suspending a fine powder of the raw material for the sealed part 2 in alcohol, dipping the open terminal parts of the bundled hollow fibre type separation membranes 1 into the paste, baking the bundle in an atmosphere of a

temperature not higher than the melting temperature of the raw material for the hollow fibre type separation membranes 1 and not lower than the melting temperature of the raw material for the sealed part 2, and then cooling the baked bundle, (2) a method which comprises melting the resin as the raw material for the sealed part 2 in a depressed metallic die to a temperature not higher than the melting temperature of the raw material for the hollow fibre type separating membranes 1, inserting the open terminal parts of the bundled hollow fibre type separation membranes 1 into the melt of the raw material for the sealed part 2 to conduct first sealing, again inserting the open terminal parts of the bundled hollow fibre type separation membranes 1 into the melt of the raw material for the sealed part 2 while the melt is at a temperature not higher than the melting temperature of the raw material for the hollow fibre type separation membranes 1 to conduct second sealing, and then cooling the bundle, and (3) a method which comprises melting polyurethane or epoxy resin in the same manner as the conventional sealed part and casing the resultant melt of the raw material for the sealed part 2 into a given mould while the melt is at a temperature not higher than the melting temperature of the raw material for the hollow fibre type separation membranes 1, for example.

The effects manifested by the difference in properties of the hollow fibre type separation membranes 1 on the insertion of the hollow fibre type separation membranes 1 in the melt of thermoplastic resin as the raw material for the sealed part will be described below with reference to the Tables shown below.

The flexure at the free end of the hollow fibre type separation membranes under their own weight when supported in the manner of a cantilever is shown in Table 1.

Table 1

Flexure (mm)	Result of Insertion of Hollow Fibre Type Semi-permeable Membranes
30	Good
<65	Good, depending on conditions of insertion
100	Bad, with reference to conditions of insertion
150	Bad, with reference to conditions of insertion

The relationship between the strength of the hollow fibre type separation membranes at rupture and the condition of damage by insertion of the hollow fibre type semipermeable membranes is shown in Table 2.

Table 2

Strength at Rupture	Condition of Damage by Insertion of Hollow Fibre Type Semipermeable Membranes
120 gf/membrane	No damage by insertion
90 gf/membrane	No damage by insertion
60 gf/membrane	Insertion without damage obtainable, depending on conditions of insertion
30 gf/membrane	No insertion obtainable, without reference to conditions of insertion

From the results given above, it is clear that the terminal parts of the hollow fibre type separation membranes can be inserted in a perfect state into the thermoplastic resin when the hollow fibre type separation membranes have a flexure of not more than 65 mm under the weight of their own and a strength of not less than 60 gf/membrane at rupture. The conditions for the insertion to be used when the flexure under weight is 65 mm and the strength at rupture is 60 gf/membrane are 50,000 to 500,000 cp of the viscosity of thermoplastic resin, 0.05 to 5 mm/min of the speed of insertion, and not less than 20°C as the difference between the melting points of the thermoplastic resin and the hollow fibre type separation membranes.

It is, therefore, appropriate to select hollow fibre type semipermeable membranes 1 of a quality such that the flexure under weight may be not more than 65 mm in the free end of a cantilever 150 mm in length and that the strength at rupture may be not less than 60 gf/membrane.

Now, a method for the production of a filter element which fulfils the conditions mentioned above will be cited below by way of example.

Hollow fibre type separation membranes 150 mm in length using polypropylene resin as the raw material and manifesting a flexure under weight of 30 mm in the free end of a cantilever and a strength of 160 gf/membrane at rupture are bundled so that the ratio of the cross section of the sealed part to the total cross section of the bundled hollow fibre type separation membranes may fall in the range of 30 to 65%, and the open terminal parts of the bundled hollow fibre type separation membranes are sealed.

The polyethylene resin as the raw material for the sealed part is melted at a temperature not higher than the thermally melting temperature or the decomposing temperature of the polypropylene resin as the raw material for the hollow fibre type separation membranes and not lower than the melting temperature of the polyethylene resin, and the open terminal parts of the bundled hollow fibre type separation membranes are inserted in the resultant melt. At this time, the polyethylene resin has a melt viscosity in the range of 50,000 to 500,000 cp and the hollow fibre type separation membranes are inserted at a rate in the range of 0.05 to 5 mm/min.

Subsequently, the molten polyethylene resin is gradually cooled and solidified at a temperature about 20°C lower than the melting point of the polyethylene resin to form a sealed part in a half-bonded state showing no perfect compatibility with the hollow fibre type separation membranes and permitting persistence of a definite interface of bondage therebetween. Then, the open terminal parts of the bundle of a plurality of hollow fibre type separation membranes watertightly sealed in the sealing part are opened by cutting off or thermally melting the leading ends of the sealed part.

Now, working examples of the module of filter element according to this invention will be described in detail below in combination with comparative experiments.

Comparative Experiment 1

A module of filter element was formed by bundling 590 hollow fibre type separation membranes made of polypropylene, 0.1 μm in maximum pore diameter, 400 μm in outside diameter and 250 μm in inside diameter, inserting the bundle in an outer tube made of polycarbonate, and forming a sealed part made of polyurethane by the conventional method of centrifugal casting. Then, this module of filter element was kept immersed in isopropyl alcohol at room temperature for 100 days, dried at 60°C for 48 hours, again immersed in isopropyl alcohol, and tested by the standard method for the determination of bubble point. The test could not be accomplished because the sealed part of polyurethane and the outer tube of polycarbonate separated along the interface of bondage.

Comparative Experiment 2

A module of filter element was formed by bundling 800 fibre type separation membranes made of polysulfone, 0.1 μm in maximum pore diameter, 450 μm in outside diameter and 300 μm in inside diameter, inserting the bundle in an outer tube made of polycarbonate, and forming a sealed part made of epoxy resin by the conventional method of centrifugal casting. Then, this module was kept immersed in an aqueous alkaline detergent solution of pH 12 at 60°C for two weeks, washed with water, and tested with water for the determination of bubble point. The test could not be accomplished because the sealed part of epoxy resin and the outer tube of polycarbonate separated along the interface of bondage.

Comparative Experiment 3

An effort to form a module of filter element by bundling 600 hollow fibre type separation membranes made of polypropylene, 0.1 μm in maximum pore diameter, 400 μm in outside diameter and 250 μm in inside diameter, preparing paste by suspending fine powder of polypropylene in methyl alcohol, applying the paste to the open terminal parts of the bundled hollow fibre type separation membranes, inserting the bundle in an outer tube made of polypropylene, and forming a sealed part by locally heating the neighbourhood of the open terminal parts of the hollow fibre type separation membranes at 180°C in accordance with the method disclosed in JP-P-A-01-164405 failed because the neighbourhood of base of the sealed part of the hollow fibre type separation membranes was melted and, at the same time, the parts of the hollow fibre type separation membranes embedded in the sealed part were melted and wholly disintegrated.

The formation of a module of filter element capable of resisting chemical and physical invasion by using a thermoplastic resin as the material for a sealed part formed in the open terminal parts of bundled hollow fibre type separation membranes has been conceived as partly disclosed in JP-P-A-01-164405. As demonstrated in the comparative experiments, however, the measure which consists in using as the material for a sealed part a thermoplastic resin simply on account of compatibility thereof with the hollow fibre type separation membranes and thermally melting this thermoplastic resin actually was capable of forming the sealed part only with a resin of very poor flowability at the melting point even when the material for the hollow fibre type separation membranes was such a thermoplastic resin as PTFE because the neighbourhood of the base of the sealed part of the hollow fibre type separation membranes and the part embedded in the sealed part were liable to melt and disintegrate.

Example 1

A module of filter element was formed by bundling 620 hollow fibre type separation membranes made of polypropylene, 0.1 μm in maximum pore diameter, 400 μm in outside diameter and 250 μm in inside diameter, inserting the bundle in an outer tube made of low-density polyethylene, preparing paste by dispersing the raw material for a sealed part in ethyl alcohol, injecting the paste in the opposite open terminals of the outer tube, baking the outer tube thus prepared in an oven at 120°C for 12 hours, and allowing the baked outer tube to stand and then cool off in the oven. This module was kept immersed in isopropyl alcohol at room temperature for 120 days, dried at 60°C for 48 hours, immersed again in isopropyl alcohol, and tested for bubble point. It was consequently found to have a bubble point value of 3.4 kg/cm^2 , a normal level.

Example 2

A module of filter element was formed by bundling 780 hollow fibre type separation membranes made of polysulfone, 0.1 μm in maximum pore diameter, 450 μm in outside diameter and 300 μm in inside diameter, inserting the bundle in an outer tube made of high-density polyethylene, melting high-density polyethylene in advance at 140°C in a depressed metallic die, inserting the open terminal parts of the bundled hollow fibre type separation membranes in the melt of high-density polyethylene, and allowing the wetted open terminal parts to cool off gradually. Then, this module was kept immersed in an aqueous alkaline detergent solution of pH 12 at 60°C for 15 days, washed with water, and tested for bubble point. It was consequently found to have a bubble point value of 3.8 kg/cm^2 , a normal level.

Example 3

A module of filter element was formed by bundling 50 ultrafilter membranes made of polysulfone, 1200 μm in outside diameter and 700 μm in inside diameter, inserting the bundle into an outer tube made of polypropylene, preparing the raw material for a sealed part in the form of paste having a fine powder of polypropylene dispersed in ethyl alcohol, inserting the open terminal parts of the hollow fibre type separation membranes in the paste, heating only the open terminal parts in an oven at 180°C for 12 hours, and allowing the hot terminal parts to cool off gradually in the oven. This module was kept immersed in an aqueous 5% dilute hydrochloric acid solution at room temperature for six weeks, washed with water, and tested for leakage by the standard method of applying pneumatic pressure to the module from the primary side while immersing the module in water. It was consequently found to have no leakage.

The filter elements which were formed by using a natural or synthetic macromolecular compound as the raw material for hollow fibre type separation membranes and a thermoplastic resin as the raw material for a sealed part, setting the temperature for the formation of the sealed part at a level not higher than the thermally melting temperature or the decomposition temperature of the raw material for the formation of hollow fibre type separation membranes and not lower than the thermally melting temperature of the sealed part made of the thermoplastic resin, and forming the hollow fibre type separation membranes and the sealed part in a half-bonded state permitting persistence of a definite interface of bondage therebetween under conditions such that the physical properties of the parts of hollow fibre type separation membranes embedded in the sealed part and the exposed parts thereof might not be substantially varied, were strong enough to withstand chemical or physical invasion as compared with the filter elements formed by the conventional method using a sealed part made of polyurethane and epoxy resin.

Now, concrete examples of the cartridge of filter element and the module thereof according to this invention will be described below with reference to the accompanying drawings.

FIG. 5 is a half-cut cross section showing one example of a cartridge of filter element according to this invention. In the diagram, 1 stands for hollow fibre type semipermeable membranes made of a natural or synthetic macromolecular compound, 2 for a sealed part made of a thermoplastic resin having a melting temperature not higher than the thermally melting point or the decomposing temperature of the raw material for the hollow fibre type separation membranes, 3 for a casing for accommodating and protecting a bundle of a plurality of hollow fibre type semipermeable membranes 1, 3a for the main body of the casing 3, 3b and 3c each for the cap of the casing 3, and 4 for an O ring. The sealed part 2 watertightly seals the open terminal parts of the bundled hollow fibre type semipermeable membranes 1 and, at the same time, watertightly adheres by fusion to the inner wall surface of the open terminal part of the main body 3a of the casing 3.

FIG. 6 is a schematic front view showing a device incorporating therein another example of cartridge of filter element according to this invention. In the diagram, 5 stands for a cartridge of filter element, 6 for an outlet for a fluid, 7 for an inlet for the fluid, 8 for a housing, 9 for a clamp band, and 10 for a valve for deaeration.

FIG. 7 is a half-cut cross section showing one example of a module of filter element according to this invention. In the diagram, 11 stand for hollow fibre type semipermeable membranes made of a natural or synthetic macromolecular compound, 12 for a sealed part made of a thermoplastic resin having a melting temperature not higher than the thermally melting temperature or the decomposing temperature of the raw material for the hollow fibre type separation

membranes, 13 for a housing for accommodating and protecting a bundle of a plurality of the hollow fibre type semipermeable membranes 11, 13a for the main body of the housing 13, 13b and 13c each for the cap for the housing 13, 14 for an O ring, 15 for an inlet for a fluid, and 16 for an outlet for the fluid. The sealed part 12 watertightly seals the open terminal parts of the bundled hollow fibre type semipermeable membranes 11 and, at the same time, watertightly adheres by fusion to the inner wall surface of the open terminal part of the main body 13a of the housing 13.

It is clearly noted from the description given above that since the filter element according to this invention has the sealed part thereof formed in a half-bonded state with hollow fibre type separation membranes and consequently permits persistence of an interface of bondage therebetween, the hollow fibre type separation membranes offer strong resistance to chemical and physical invasion at no sacrifice of the inherent physical properties and have no possibility of being disintegrated or deteriorated by the heat being used during the formation of the sealed parts. Further, the sealed part can cope with various fluids because the raw material therefor is not limited to a substance identical to or compatible with the raw material for the hollow fibre type separation membranes.

Claims

15

1. A filter element comprising:

a bundle of hollow fibre type separation membranes (1) made of a natural or synthetic macromolecular material, said bundle having an opening in at least one terminal part thereof; and

a sealed part (2) made of a thermoplastic resin, bonded to said bundle at a temperature not higher than a melting or decomposing temperature of said macromolecular material, and adapted to seal watertightly said opening of said bundle in a half-bonded state showing no compatibility with said macromolecular material and permitting persistence of a mutual interface of bondage.

2. A filter element according to claim 1, wherein said hollow fibre type separation membranes are asymmetric membranes having a smooth skin layer on an inner surface thereof and a finely jogging support layer on an outer surface thereof.

3. A filter element according to claim 2, wherein said asymmetric membranes are reverse osmosis membranes.

30

4. A filter element according to claim 2, wherein said asymmetric membranes are ultrafilter membranes.

5. A filter element according to claim 2, wherein said asymmetric membranes are gas separation membranes.

6. A filter element according to any preceding claim, wherein said hollow fibre type separation membranes are microporous hollow fibre type separation membranes containing pores of a largest diameter in the range of 0.01 to 5 μm .

7. A filter element according to any preceding claim, wherein said macromolecular material is one member selected from the group consisting of cellulose, cellulose ester, polysulfone, polyether sulfone, polypropylene, polyethylene, polyamide, and polyacrylonitrile.

40

8. A filter element according to any preceding claim, wherein said thermoplastic resin is one member selected from the group consisting of a polyolefin type resin, a copolymer of tetrafluoroethylene with polyfluoroalkyl ethers and a fluorine type resin.

45

9. A filter element according to claim 8, wherein said polyolefin type resin is one member selected from the group consisting of polyethylene and polypropylene.

10. A filter element according to claim 8, wherein said fluorine type resin is one member selected from the group consisting of polytetrafluoroethylene and fluorinated ethylene propylene.

50

11. A filter element according to any preceding claim, wherein said hollow fibre type separation membranes have a length of 150 mm, manifest a flexure of not more than 65 mm at a free end thereof under their own weight when supported in the manner of a cantilever, and exhibit strength of not less than 60 gf/membrane at rupture.

55

FIG. 1

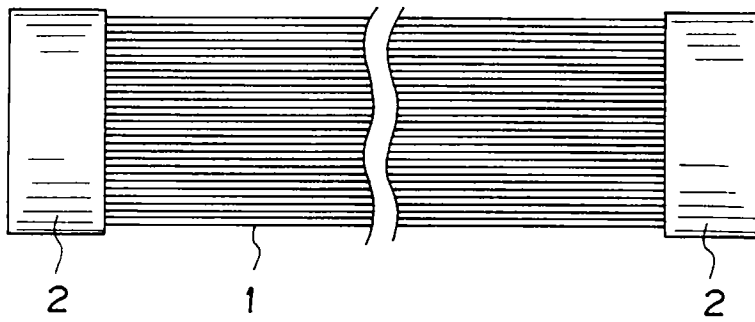

FIG. 2

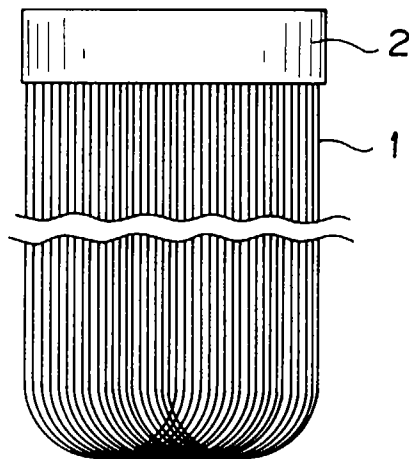

FIG. 3



FIG. 4



FIG. 5

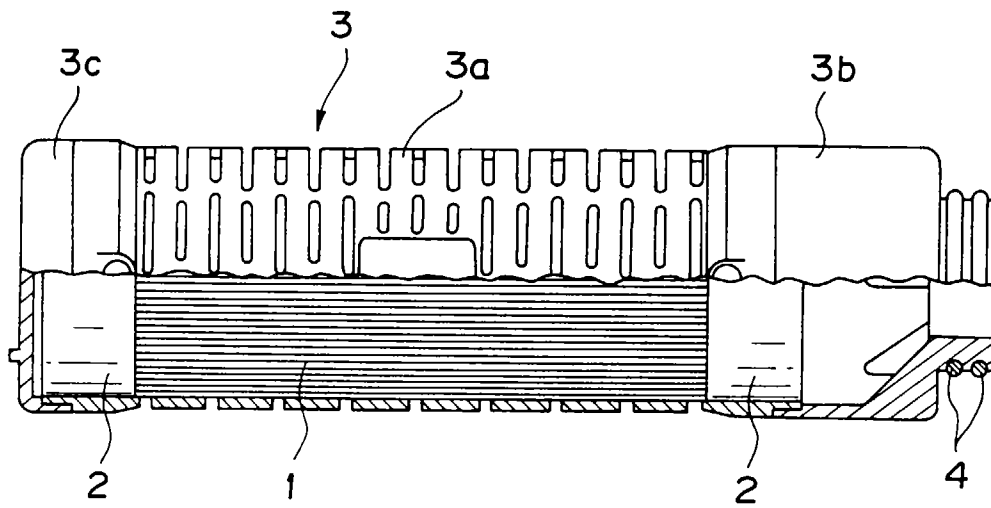

FIG. 6

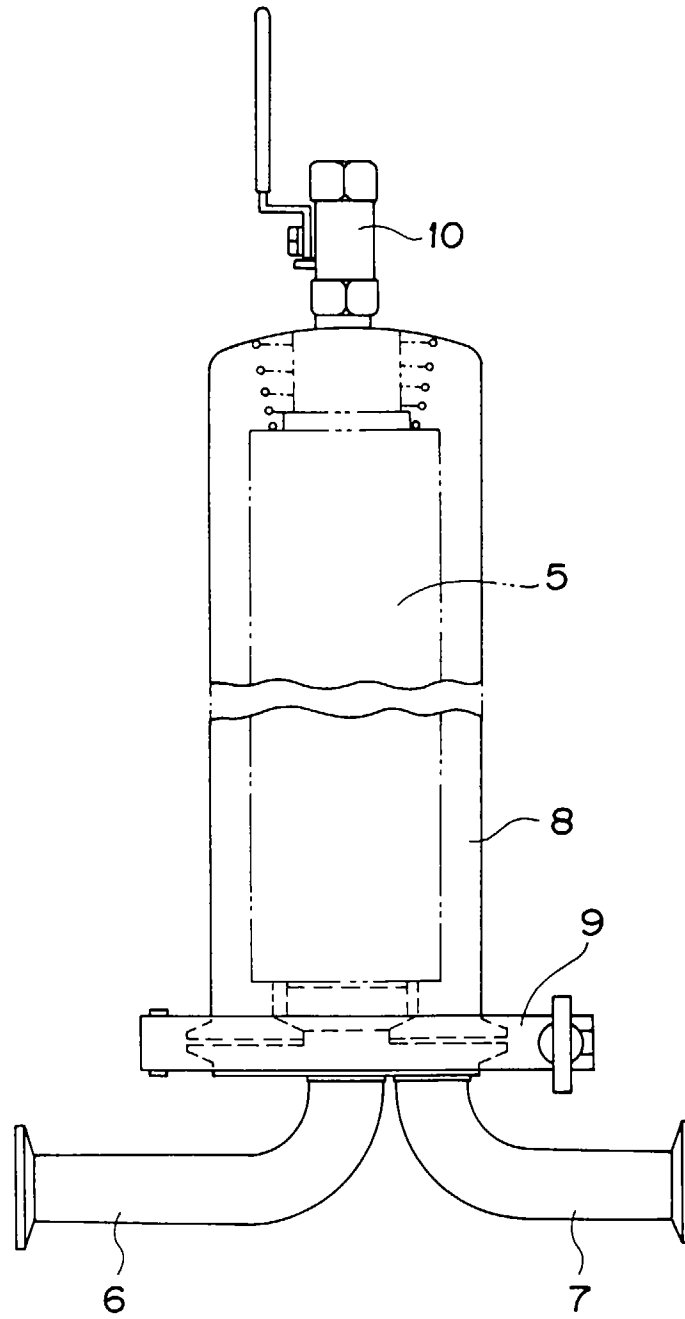
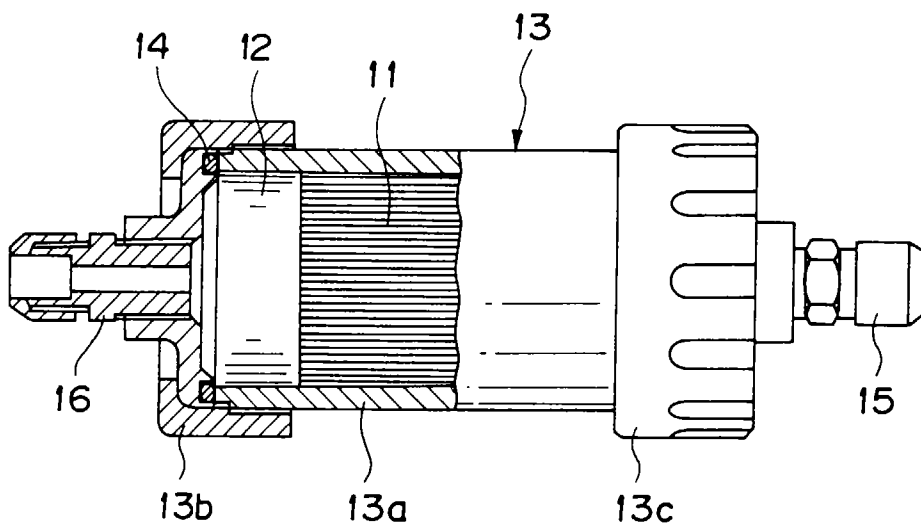

FIG. 7





European Patent
Office

EUROPEAN SEARCH REPORT

Application Number
EP 97 30 0119

DOCUMENTS CONSIDERED TO BE RELEVANT			
Category	Citation of document with indication, where appropriate, of relevant passages	Relevant to claim	CLASSIFICATION OF THE APPLICATION (Int.Cl.6)
X	US 5 284 584 A (X.HUANG ET AL) * column 11, line 39-43; claims 1,8,17 * ---	1,7-10	B01D63/02 B01D65/00
A	WO 96 01143 A (MILLIPORE CORPORATION) * claims 1,21,22,24,26 * ---	1,7-9	
A	PATENT ABSTRACTS OF JAPAN vol. 16, no. 261 (C-0950), 12 June 1992 & JP 04 063117 A (KITZ CORP), 28 February 1992, * abstract * ---	1,7-9	
A	EP 0 338 582 A (UNION CARBIDE CORPORATION) * claim 7 * ---	1	
A	DE 32 40 143 A (AKZO GMBH) * claim 1 * ---	1	
A,D	PATENT ABSTRACTS OF JAPAN vol. 14, no. 53 (C-0683), 31 January 1990 & JP 01 281104 A (ASAHI CHEM IND CO LTD) * abstract * -----	1	
			TECHNICAL FIELDS SEARCHED (Int.Cl.6)
			B01D
The present search report has been drawn up for all claims			
Place of search		Date of completion of the search	Examiner
BERLIN		8 July 1997	Cordero Alvarez, M
CATEGORY OF CITED DOCUMENTS			
X : particularly relevant if taken alone Y : particularly relevant if combined with another document of the same category A : technological background O : non-written disclosure P : intermediate document		T : theory or principle underlying the invention E : earlier patent document, but published on, or after the filing date D : document cited in the application L : document cited for other reasons & : member of the same patent family, corresponding document	

EPO FORM 1503 (03.92) (P/4C01)