



(51) International Patent Classification:

H04L 12/823 (2013.01) H04L 12/801 (2013.01)
H04L 12/835 (2013.01)

(21) International Application Number:

PCT/KR2017/004360

(22) International Filing Date:

25 April 2017 (25.04.2017)

(25) Filing Language:

English

(26) Publication Language:

English

(30) Priority Data:

62/330,232 01 May 2016 (01.05.2016) US
62/339,930 22 May 2016 (22.05.2016) US

(71) Applicant: **LG ELECTRONICS INC.** [KR/KR]; 128, Yeoui-daero, Yeongdeungpo-gu, Seoul 07336 (KR).

(72) Inventors: **LEE, Jaewook**; IP Center, LG Electronics Inc., 19, Yangjae-daero 11-gil, Seocho-gu, Seoul 06772 (KR). **LEE, Youngdae**; IP Center, LG Electronics Inc., 19, Yangjae-daero 11-gil, Seocho-gu, Seoul 06772 (KR). **KIM, Laeyoung**; IP Center, LG Electronics Inc., 19, Yangjae-daero 11-gil, Seocho-gu, Seoul 06772 (KR). **KIM, Dongsoo**; IP Center, LG Electronics Inc., 19, Yangjae-daero 11-gil, Seocho-gu, Seoul 06772 (KR).

(74) Agent: **KIM, Yong In** et al.; KBK & Associates, 7th Floor, 82, Olympic-ro, Songpa-ku, Seoul 05556 (KR).

(81) Designated States (unless otherwise indicated, for every kind of national protection available): AE, AG, AL, AM, AO, AT, AU, AZ, BA, BB, BG, BH, BN, BR, BW, BY, BZ, CA, CH, CL, CN, CO, CR, CU, CZ, DE, DJ, DK, DM, DO, DZ, EC, EE, EG, ES, FI, GB, GD, GE, GH, GM, GT, HN, HR, HU, ID, IL, IN, IR, IS, JP, KE, KG, KH, KN, KP, KR, KW, KZ, LA, LC, LK, LR, LS, LU, LY, MA, MD, ME, MG, MK, MN, MW, MX, MY, MZ, NA, NG, NI, NO, NZ, OM, PA, PE, PG, PH, PL, PT, QA, RO, RS, RU, RW, SA, SC,

SD, SE, SG, SK, SL, SM, ST, SV, SY, TH, TJ, TM, TN, TR, TT, TZ, UA, UG, US, UZ, VC, VN, ZA, ZM, ZW.

(84) Designated States (unless otherwise indicated, for every kind of regional protection available): ARIPO (BW, GH, GM, KE, LR, LS, MW, MZ, NA, RW, SD, SL, ST, SZ, TZ, UG, ZM, ZW), Eurasian (AM, AZ, BY, KG, KZ, RU, TJ, TM), European (AL, AT, BE, BG, CH, CY, CZ, DE, DK, EE, ES, FI, FR, GB, GR, HR, HU, IE, IS, IT, LT, LU, LV, MC, MK, MT, NL, NO, PL, PT, RO, RS, SE, SI, SK, SM, TR), OAPI (BF, BJ, CF, CG, CI, CM, GA, GN, GQ, GW, KM, ML, MR, NE, SN, TD, TG).

Published:

— without international search report and to be republished upon receipt of that report (Rule 48.2(g))

(54) Title: METHOD FOR MANAGING PACKETS FOR V2X COMMUNICATION AND APPARATUS THEREFOR

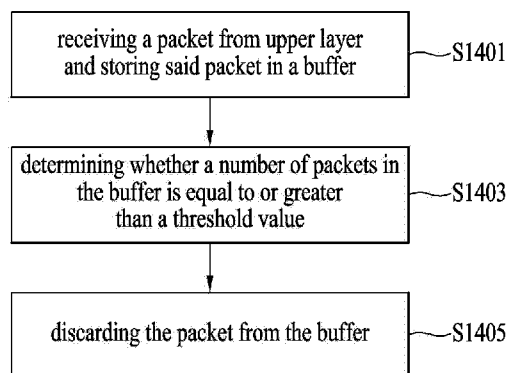

(57) Abstract: A method for discarding at least one packet by a user equipment (UE) in a wireless communication system is disclosed. The method includes steps of storing the at least one packet received from an upper layer in a buffer; determining whether or not a number of packets in the buffer is equal to or greater than a threshold value; and discarding the at least one packet from the buffer when the number of packets in the buffer is equal to or greater than the threshold value.



Description

Title of Invention: METHOD FOR MANAGING PACKETS FOR V2X COMMUNICATION AND APPARATUS THEREFOR

Technical Field

- [1] The present invention relates to a wireless communication system and, more particularly, to a method for managing packets for a V2X (Vehicle-to-Everything) communication and an apparatus therefor.

Background Art

- [2] As an example of a mobile communication system to which the present invention is applicable, a 3rd Generation Partnership Project Long Term Evolution (hereinafter, referred to as LTE) communication system is described in brief.
- [3] FIG. 1 is a view schematically illustrating a network structure of an E-UMTS as an exemplary radio communication system. An Evolved Universal Mobile Telecommunications System (E-UMTS) is an advanced version of a conventional Universal Mobile Telecommunications System (UMTS) and basic standardization thereof is currently underway in the 3GPP. E-UMTS may be generally referred to as a Long Term Evolution (LTE) system. For details of the technical specifications of the UMTS and E-UMTS, reference can be made to Release 7 and Release 8 of "3rd Generation Partnership Project; Technical Specification Group Radio Access Network".
- [4] Referring to FIG. 1, the E-UMTS includes a User Equipment (UE), eNode Bs (eNBs), and an Access Gateway (AG) which is located at an end of the network (E-UTRAN) and connected to an external network. The eNBs may simultaneously transmit multiple data streams for a broadcast service, a multicast service, and/or a unicast service.
- [5] One or more cells are present per eNB. A cell is configured to use one of bandwidths of 1.44, 3, 5, 10, 15, and 20MHz to provide a downlink or uplink transport service to several UEs. Different cells may be set to provide different bandwidths. The eNB controls data transmission and reception for a plurality of UEs. The eNB transmits downlink scheduling information with respect to downlink data to notify a corresponding UE of a time/frequency domain in which data is to be transmitted, coding, data size, and Hybrid Automatic Repeat and reQuest (HARQ)-related information. In addition, the eNB transmits uplink scheduling information with respect to uplink data to a corresponding UE to inform the UE of an available time/frequency domain, coding, data size, and HARQ-related information. An interface may be used to transmit user traffic or control traffic between eNBs. A Core Network (CN) may include the AG, a network node for user registration of the UE, and the like. The AG

manages mobility of a UE on a Tracking Area (TA) basis, each TA including a plurality of cells.

- [6] Although radio communication technology has been developed up to LTE based on Wideband Code Division Multiple Access (WCDMA), demands and expectations of users and providers continue to increase. In addition, since other radio access technologies continue to be developed, new advances in technology are required to secure future competitiveness. For example, decrease of cost per bit, increase of service availability, flexible use of a frequency band, simple structure, open interface, and suitable power consumption by a UE are required.

Disclosure of Invention

Technical Problem

- [7] Based on the above discussion, the present invention proposes a method for managing packets for a V2X (Vehicle-to-Everything) communication and an apparatus therefor.

Solution to Problem

- [8] In accordance with an embodiment of the present invention, a method for discarding at least one packet by a user equipment (UE) in a wireless communication system is disclosed. The method includes the steps of storing the at least one packet received from an upper layer in a buffer; determining whether or not a number of packets in the buffer is equal to or greater than a threshold value; and discarding the at least one packet from the buffer when the number of packets in the buffer is equal to or greater than the threshold value.
- [9] Further, in accordance with another embodiment of the present invention, a user equipment (UE) in a wireless communication system is disclosed. The UE comprises a radio frequency (RF) unit; and a processor connected with the RF unit and configured to store the at least one packet received from an upper layer in a buffer, determine whether or not a number of packets in the buffer is equal to or greater than a threshold, and discard the at least one packet from the buffer when the number of packets in the buffer is equal to or greater than the threshold value.
- [10] As a special case, if the threshold value is 1, the at least one packet is discarded upon a detection of ingress of another packet into the buffer.
- [11] Preferably, when determining whether or not the number of packets in the buffer is equal to or greater than the threshold value or not, only packets having same priority may be considered. Therefore, the determining comprises determining whether or not a number of packets having same priority in the buffer is equal to or greater than the threshold value.
- [12] Preferably, information about the threshold value may be provided from the network.

Especially, the threshold value is configured per bearer

[13] Furthermore, according to the present invention, it is preferable to determine whether a zone in which the UE is located is changed or not. In this case, when the zone is changed, the at least one packet is discarded from the buffer.

[14] It is to be understood that both the foregoing general description and the following detailed description of the present invention are exemplary and explanatory and are intended to provide further explanation of the invention as claimed.

Advantageous Effects of Invention

[15] According to embodiments of the present invention, the UE can manage packets efficiently for the V2X communication.

[16] It will be appreciated by persons skilled in the art that that the effects that can be achieved through the present invention are not limited to what has been particularly described hereinabove and other advantages of the present invention will be more clearly understood from the following detailed description.

Brief Description of Drawings

[17] The accompanying drawings, which are included to provide a further understanding of the invention and are incorporated in and constitute a part of this application, illustrate embodiment(s) of the invention and together with the description serve to explain the principle of the invention.

[18] In the drawings:

[19] FIG. 1 is a diagram showing a network structure of an Evolved Universal Mobile Telecommunications System (E-UMTS) as an example of a wireless communication system.

[20] FIG. 2 is a diagram showing the concept of a network structure of an Evolved Universal Terrestrial Radio Access Network (E-UTRAN).

[21] FIG. 3 is a diagram showing a control plane and a user plane of a radio interface protocol between a User Equipment (UE) and an Evolved Universal Terrestrial Radio Access Network (E-UTRAN) based on a 3rd Generation Partnership Project (3GPP) radio access network standard.

[22] FIG. 4 is a diagram showing physical channels used in a 3GPP system and a general signal transmission method using the same.

[23] FIG. 5 is a diagram showing the structure of a radio frame used in a Long Term Evolution (LTE) system.

[24] FIG. 6 is an example of default data path for a normal communication;

[25] FIGs. 7 and 8 are examples of data path scenarios for a proximity communication;

[26] FIG. 9 is a conceptual diagram illustrating for a non-roaming reference architecture;

[27] FIG. 10 is a conceptual diagram illustrating for a Layer 2 Structure for Sidelink;

- [28] FIG. 11 is a conceptual diagram illustrating for protocol stack for ProSe Direct Communication;
- [29] FIG. 12 is a conceptual diagram illustrating for a PC5 interface for ProSe Direct Discovery;
- [30] FIG. 13 is a conceptual diagram illustrating for Vehicle-to-Everything (V2X) communication;
- [31] FIG. 14 is a flow chart illustrating an operation in accordance with an embodiment of the present invention; and
- [32] FIG. 15 is a block diagram of a communication apparatus according to an embodiment of the present invention.

Best Mode for Carrying out the Invention

- [33] Hereinafter, structures, operations, and other features of the present invention will be readily understood from the embodiments of the present invention, examples of which are illustrated in the accompanying drawings. Embodiments described later are examples in which technical features of the present invention are applied to a 3GPP system.
- [34] Although the embodiments of the present invention are described using a long term evolution (LTE) system and a LTE-advanced (LTE-A) system in the present specification, they are purely exemplary. Therefore, the embodiments of the present invention are applicable to any other communication system corresponding to the above definition. In addition, although the embodiments of the present invention are described based on a frequency division duplex (FDD) scheme in the present specification, the embodiments of the present invention may be easily modified and applied to a half-duplex FDD (H-FDD) scheme or a time division duplex (TDD) scheme.
- [35] FIG. 2 is a diagram showing the concept of a network structure of an Evolved Universal Terrestrial Radio Access Network (E-UTRAN). In particular, the E-UTRAN system is a system evolved from the existing UTRAN system. The E-UTRAN includes cells (eNBs) and cells are connected via an X2 interface. A cell is connected to a user equipment (UE) via an air interface and is connected to an evolved packet core (EPC) via an S1 interface.
- [36] The EPC includes a mobility management entity (MME), a serving-gateway (S-GW) and a packet data network-gateway (PDN-GW). The MME has access information of a UE and information about capabilities of the UE. Such information is mainly used for mobility management of the UE. The S-GW is a gateway having an E-UTRAN as an end point and the PDN-GW is a gateway having a PDN as an end point.
- [37] FIG. 3 shows a control plane and a user plane of a radio interface protocol between a UE and an Evolved Universal Terrestrial Radio Access Network (E-UTRAN) based on

a 3GPP radio access network standard. The control plane refers to a path used for transmitting control messages used for managing a call between the UE and the network. The user plane refers to a path used for transmitting data generated in an application layer, e.g., voice data or Internet packet data.

- [38] A physical (PHY) layer of a first layer provides an information transfer service to a higher layer using a physical channel. The PHY layer is connected to a Medium Access Control (MAC) layer located on a higher layer via a transport channel. Data is transported between the MAC layer and the PHY layer via the transport channel. Data is also transported between a physical layer of a transmitting side and a physical layer of a receiving side via a physical channel. The physical channel uses a time and a frequency as radio resources. More specifically, the physical channel is modulated using an Orthogonal Frequency Division Multiple Access (OFDMA) scheme in downlink and is modulated using a Single-Carrier Frequency Division Multiple Access (SC-FDMA) scheme in uplink.
- [39] A medium access control (MAC) layer, a radio link control (RLC) layer and a packet data convergence protocol (PDCP) layer may be located in a second layer. The MAC layer of the second layer serves to map various logical channels to various transport channels. The MAC layer performs a logical channel multiplexing function for mapping several logical channels to one transport channel. The MAC layer is connected to a Radio Link Control (RLC) layer, which is a higher layer, via a logical channel, and the logical channel may be roughly divided into a control channel for transmitting information about the control plane and a traffic channel for transmitting information about the user plane, according to the type of transmitted information.
- [40] The RLC layer of the second layer segments and concatenates data received from a higher layer, thereby controlling a data size suitable for enabling a lower layer to transmit data in a radio interval. The RLC layer provides three modes, namely, a transparent mode (TM), an unacknowledged mode (UM) and an acknowledged mode (AM) to support a variety of QoS requested by each radio bearer (RB). Especially, for reliable data transmission, the AM RLC performs a function to retransmit data through automatic repeat request (ARQ).
- [41] The packet data convergence protocol (PDCP) layer of the second layer performs a header compression function for reducing the size of an IP packet header which is relatively great in size and includes unnecessary control information in order to efficiently transmit IP packets, such as IPv4 or IPv6 packets, in a radio interval with a relatively narrow bandwidth. Accordingly, only necessary information need be included in the header part of data for transmission, so as to increase transmission efficiency of a radio interval. In the LTE system, the PDCP layer also performs a security function. The security function includes a ciphering function for preventing

data monitoring from a third party, and an integrity protection function for preventing third party data manipulation.

- [42] A radio resource control (RRC) layer of the third layer is defined only in the control plane. The RRC layer handles logical channels, transport channels and physical channels for the configuration, re-configuration and release of radio bearers (RBs). Here, a radio bearer (RB) denotes a service provided by the second layer for data transfer between the UE and the network. The RRC layers of the UE and the network exchange RRC messages with each other.
- [43] The RB may be broadly divided into two bearers, that is, a signaling radio bearer (SRB) used to transmit an RRC message on a control plane and a data radio bearer (DRB) used to transmit user data on a user plane. The DRB may be divided into a UM DRB using UM RLC and AM DRB using AM RLC according to method for operating RLC.
- [44] Hereinafter, an RRC state of a UE and an RRC connection method will be described. The RRC state, which indicates whether the RRC layer of the UE is logically connected to the RRC layer of the E-UTRAN, is called an RRC_CONNECTED state if the RRC layers are connected and is called an RRC_IDLE state if the RRC layers are not connected.
- [45] Since the E-UTRAN detects presence of a UE in an RRC_CONNECTED state in cell units, it is possible to efficiently control the UE. In contrast, the E-UTRAN cannot detect a UE in an RRC_IDLE state in cell units and a core network (CN) manages the UE in an RRC_IDLE state in units of TA which is greater than a cell. That is, the UE in the RRC_IDLE state transitions to the RRC_CONNECTED state in order to receive a service such as voice or data from a cell.
- [46] In particular, when a user first turns a UE on, the UE searches for an appropriate cell and then camps on an RRC_IDLE state in the cell. The UE in the RRC_IDLE state performs an RRC connection establishment process with the RRC layer of the E-UTRAN to transition to the RRC_CONNECTED state when RRC connection needs to be established. The RRC connection needs to be established when uplink data transmission is necessary due to call connection attempt of a user, when a response message is transmitted in response to a paging message received from the E-UTRAN, etc.
- [47] A non-access stratum (NAS) layer located above the RRC layer performs a function such as session management and mobility management. In the NAS layer, two states such as an EPS mobility management-REGISTERED (EMM-REGISTERED) state and an EMM-UNREGISTERED state are defined in order to manage mobility of a UE. These two states are applied to the UE and the MME. A UE is first in the EMM-UNREGISTERED state and performs a process of registering with a network through

- an initial attach procedure in order to access the network. If the attach procedure is successfully performed, the UE and the MME enter the EMM-REGISTERED STATE.
- [48] In the NAS layer, in order to manage signaling connection between the UE and the EPC, an EPS connection management (ECM)-IDLE state and an ECM_CONNECTED state are defined and applied to the UE and the MME. If a UE in the ECM-IDLE state is RRC connected to the E-UTRAN, the UE enters the ECM-CONNECTED state. If the MME in the ECM-IDLE state is S1 connected to the E-UTRAN, the MME enters the ECM-CONNECTED state.
- [49] When the UE is in the ECM-IDLE state, the E-UTRAN does not have context information of the UE. Accordingly, the UE in the ECM-IDLE state performs a UE-based mobility associated procedure, such as cell selection or reselection, without receiving a command of the network. In contrast, if the UE is in the ECM-CONNECTED state, mobility of the UE is managed by the command of the network. If the location of the UE is changed in the ECM-IDLE state, the UE informs the network of the location thereof via a tracking area (TA) update procedure.
- [50] In an LTE system, one cell configuring an eNB is configured to use a bandwidth such as 1.25, 2.5, 5, 10, 15 or 20 MHz to provide a downlink or uplink transmission service to several UEs. Different cells may be configured to provide different bandwidths.
- [51] Downlink transport channels for transmission of data from the network to the UE include a Broadcast Channel (BCH) for transmission of system information, a Paging Channel (PCH) for transmission of paging messages, and a downlink Shared Channel (SCH) for transmission of user traffic or control messages. Traffic or control messages of a downlink multicast or broadcast service may be transmitted through a downlink SCH and may also be transmitted through a downlink multicast channel (MCH).
- [52] Uplink transport channels for transmission of data from the UE to the network include a Random Access Channel (RACH) for transmission of initial control messages and an uplink SCH for transmission of user traffic or control messages. Logical channels, which are located above the transport channels and are mapped to the transport channels, include a Broadcast Control Channel (BCCH), a Paging Control Channel (PCCH), a Common Control Channel (CCCH), a Multicast Control Channel (MCCH), and a Multicast Traffic Channel (MTCH).
- [53] FIG. 4 is a diagram showing physical channels used in a 3GPP system and a general signal transmission method using the same.
- [54] A UE performs an initial cell search operation such as synchronization with an eNB when power is turned on or the UE enters a new cell (S401). The UE may receive a Primary Synchronization Channel (P-SCH) and a Secondary Synchronization Channel (S-SCH) from the eNB, perform synchronization with the eNB, and acquire in-

formation such as a cell ID. Thereafter, the UE may receive a physical broadcast channel from the eNB so as to acquire broadcast information within the cell. Meanwhile, the UE may receive a Downlink Reference Signal (DL RS) so as to confirm a downlink channel state in the initial cell search step.

[55] The UE which has completed the initial cell search may receive a Physical Downlink Control Channel (PDCCH) and a Physical Downlink Shared Channel (PDSCH) according to information included in the PDCCH so as to acquire more detailed system information (S402).

[56] Meanwhile, if the eNB is initially accessed or radio resources for signal transmission are not present, the UE may perform a Random Access Procedure (RACH) (step S403 to S406) with respect to the eNB. In this case, the UE may transmit a specific sequence through a Physical Random Access Channel (PRACH) as a preamble (S403), and receive a response message to the preamble through the PDCCH and the PDSCH corresponding thereto (S404). In case of contention based RACH, a contention resolution procedure may be further performed.

[57] The UE which has performed the above procedures may perform PDCCH/PDSCH reception (S407) and Physical Uplink Shared Channel (PUSCH)/Physical Uplink Control Channel (PUCCH) transmission (S408) as a general uplink/downlink signal transmission procedure. In particular, the UE receives downlink control information (DCI) via a PDCCH. The DCI includes control information such as resource allocation information of the UE and the format thereof is changed according to use purpose.

[58] The control information transmitted from the UE to the eNB in uplink or transmitted from the eNB to the UE in downlink includes a downlink/uplink ACK/NACK signal, a Channel Quality Indicator (CQI), a Precoding Matrix Index (PMI), a Rank Indicator (RI), and the like. In case of the 3GPP LTE system, the UE may transmit the control information such as CQI/PMI/RI through the PUSCH and/or the PUCCH.

[59] FIG. 5 is a diagram showing the structure of a radio frame used in a Long Term Evolution (LTE) system.

[60] Referring to FIG. 5, the radio frame has a length of 10 ms ($327200 \times T_s$) and includes 10 subframes with the same size. Each subframe has a length of 1 ms and includes two slots. Each slot has a length of 0.5 ms ($15360 \times T_s$). T_s denotes a sampling time, and is represented by $T_s = 1 / (15 \text{ kHz} \times 2048) = 3.2552 \times 10^{-8}$ (about 33 ns). Each slot includes a plurality of OFDM symbols in a time domain, and includes a plurality of resource blocks (RBs) in a frequency domain. In the LTE system, one RB includes 12 sub-carriers \times 7(6) OFDM or SC-FDMA symbols. A Transmission Time Interval (TTI) which is a unit time for transmission of data may be determined in units of one or more subframes. The structure of the radio frame is only exemplary and the number of subframes included in the radio frame, the number of slots included in the subframe, or

the number of OFDM symbols included in the slot may be variously changed.

- [61] Recently, Proximity-based Service (ProSe) has been discussed in 3GPP. The ProSe enables different UEs to be connected (directly) each other (after appropriate procedure(s), such as authentication), through eNB only (but not further through Serving Gateway (SGW) / Packet Data Network Gateway (PDN-GW, PGW)), or through SGW/PGW. Thus, using the ProSe, device to device direct communication can be provided, and it is expected that every devices will be connected with ubiquitous connectivity. Direct communication between devices in a near distance can lessen the load of network. Recently, proximity-based social network services have come to public attention, and new kinds of proximity-based applications can be emerged and may create new business market and revenue. For the first step, public safety and critical communication are required in the market. Group communication is also one of key components in the public safety system. Required functionalities are: Discovery based on proximity, Direct path communication, and Management of group communications.
- [62] Use cases and scenarios are for example: i) Commercial/social use, ii) Network of-flooding, iii) Public Safety, iv) Integration of current infrastructure services, to assure the consistency of the user experience including reachability and mobility aspects, and v) Public Safety, in case of absence of EUTRAN coverage (subject to regional regulation and operator policy, and limited to specific public-safety designated frequency bands and terminals)
- [63] FIG. 6 is an example of default data path for communication between two UEs. With reference to FIG. 6, even when two UEs (e.g., UE1, UE2) in close proximity communicate with each other, their data path (user plane) goes via the operator network. Thus a typical data path for the communication involves eNB(s) and/or Gateway(s) (GW(s)) (e.g., SGW/PGW).
- [64] FIGs. 7 and 8 are examples of data path scenarios for a proximity communication. If wireless devices (e.g., UE1, UE2) are in proximity of each other, they may be able to use a direct mode data path (FIG. 7) or a locally routed data path (FIG. 8). In the direct mode data path, wireless devices are connected directly each other (after appropriate procedure(s), such as authentication), without eNB and SGW/PGW. In the locally routed data path, wireless devices are connected each other through eNB only.
- [65] FIG. 9 is a conceptual diagram illustrating for a non-roaming reference architecture.
- [66] PC1 to PC 5 represent interfaces. PC1 is a reference point between a ProSe application in a UE and a ProSe App server. It is used to define application level signaling requirements. PC 2 is a reference point between the ProSe App Server and the ProSe Function. It is used to define the interaction between ProSe App Server and ProSe functionality provided by the 3GPP EPS via ProSe Function. One example may

be for application data updates for a ProSe database in the ProSe Function. Another example may be data for use by ProSe App Server in interworking between 3GPP functionality and application data, e.g. name translation. PC3 is a reference point between the UE and ProSe Function. It is used to define the interaction between UE and ProSe Function. An example may be to use for configuration for ProSe discovery and communication. PC4 is a reference point between the EPC and ProSe Function. It is used to define the interaction between EPC and ProSe Function. Possible use cases may be when setting up a one-to-one communication path between UEs or when validating ProSe services (authorization) for session management or mobility management in real time.

- [67] PC5 is a reference point between UE to UE used for control and user plane for discovery and communication, for relay and one-to-one communication (between UEs directly and between UEs over LTE-Uu). Lastly, PC6 is a reference point may be used for functions such as ProSe Discovery between users subscribed to different PLMNs.
- [68] EPC (Evolved Packet Core) includes entities such as MME, S-GW, P-GW, PCRF, HSS etc. The EPC here represents the E-UTRAN Core Network architecture. Interfaces inside the EPC may also be impacted albeit they are not explicitly shown in FIG. 9.
- [69] Application servers, which are users of the ProSe capability for building the application functionality, e.g. in the Public Safety cases they can be specific agencies (PSAP) or in the commercial cases social media. These applications are defined outside the 3GPP architecture but there may be reference points towards 3GPP entities. The Application server can communicate towards an application in the UE.
- [70] Applications in the UE use the ProSe capability for building the application functionality. Example may be for communication between members of Public Safety groups or for social media application that requests to find buddies in proximity. The ProSe Function in the network (as part of EPS) defined by 3GPP has a reference point towards the ProSe App Server, towards the EPC and the UE.
- [71] The functionality may include but not restricted to e.g.:
- [72] - Interworking via a reference point towards the 3rd party Applications
 - [73] - Authorization and configuration of the UE for discovery and Direct communication
 - [74] - Enable the functionality of the EPC level ProSe discovery
 - [75] - ProSe related new subscriber data and /handling of data storage; also handling of ProSe identities;
 - [76] - Security related functionality
 - [77] - Provide Control towards the EPC for policy related functionality
 - [78] - Provide functionality for charging (via or outside of EPC, e.g. offline charging)
 - [79] Especially, the following identities are used for ProSe Direct Communication:

- [80] - Source Layer-2 ID identifies a sender of a D2D packet at PC5 interface. The Source Layer-2 ID is used for identification of the receiver RLC UM entity;
- [81] - Destination Layer-2 ID identifies a target of the D2D packet at PC5 interface. The Destination Layer-2 ID is used for filtering of packets at the MAC layer. The Destination Layer-2 ID may be a broadcast, groupcast or unicast identifier; and
- [82] - SA L1 ID identifier in Scheduling Assignment (SA) at PC5 interface. SA L1 ID is used for filtering of packets at the physical layer. The SA L1 ID may be a broadcast, groupcast or unicast identifier.
- [83] No Access Stratum signaling is required for group formation and to configure Source Layer-2 ID and Destination Layer-2 ID in the UE. This information is provided by higher layers.
- [84] In case of groupcast and unicast, the MAC layer will convert the higher layer ProSe ID (i.e. ProSe Layer-2 Group ID and ProSe UE ID) identifying the target (Group, UE) into two bit strings of which one can be forwarded to the physical layer and used as SA L1 ID whereas the other is used as Destination Layer-2 ID. For broadcast, L2 indicates to L1 that it is a broadcast transmission using a pre-defined SA L1 ID in the same format as for group- and unicast.
- [85] FIG. 10 is a conceptual diagram illustrating for a Layer 2 structure for Sidelink.
- [86] The Sidelink is UE to UE interface for ProSe direct communication and ProSe Direct Discovery. Corresponds to the PC5 interface. The Sidelink comprises ProSe Direct Discovery and ProSe Direct Communication between UEs. The Sidelink uses uplink resources and physical channel structure similar to uplink transmissions. However, some changes, noted below, are made to the physical channels. E-UTRA defines two MAC entities; one in the UE and one in the E-UTRAN. These MAC entities handle the following transport channels additionally, i) sidelink broadcast channel (SL-BCH), ii) sidelink discovery channel (SL-DCH) and iii) sidelink shared channel (SL-SCH).
- [87] - Basic transmission scheme: the Sidelink transmission uses the same basic transmission scheme as the UL transmission scheme. However, sidelink is limited to single cluster transmissions for all the sidelink physical channels. Further, sidelink uses a 1 symbol gap at the end of each sidelink sub-frame.
- [88] - Physical-layer processing: the Sidelink physical layer processing of transport channels differs from UL transmission in the following steps:
- [89] i) Scrambling: for PSDCH and PSCCH, the scrambling is not UE-specific;
- [90] ii) Modulation: 64 QAM is not supported for Sidelink.
- [91] - Physical Sidelink control channel: PSCCH is mapped to the Sidelink control resources. PSCCH indicates resource and other transmission parameters used by a UE for PSSCH.
- [92] - Sidelink reference signals: for PSDCH, PSCCH and PSSCH demodulation,

reference signals similar to uplink demodulation reference signals are transmitted in the 4th symbol of the slot in normal CP and in the 3rd symbol of the slot in extended cyclic prefix. The Sidelink demodulation reference signals sequence length equals the size (number of sub-carriers) of the assigned resource. For PSDCH and PSCCH, reference signals are created based on a fixed base sequence, cyclic shift and orthogonal cover code.

- [93] - Physical channel procedure: for in-coverage operation, the power spectral density of the sidelink transmissions can be influenced by the eNB.
- [94] FIG. 11 is a conceptual diagram illustrating for protocol stack for ProSe Direct Communication.
- [95] FIG. 11(a) shows the protocol stack for the user plane, where PDCP, RLC and MAC sublayers (terminate at the other UE) perform the functions listed for the user plane (e.g. header compression, HARQ retransmissions). The PC5 interface consists of PDCP, RLC, MAC and PHY as shown in FIG. 11a.
- [96] User plane details of ProSe Direct Communication: i) MAC sub header contains LCIDs (to differentiate multiple logical channels), ii) The MAC header comprises a Source Layer-2 ID and a Destination Layer-2 ID, iii) At MAC Multiplexing/demultiplexing, priority handling and padding are useful for ProSe Direct communication, iv) RLC UM is used for ProSe Direct communication, v) Segmentation and reassembly of RLC SDUs are performed, vi) A receiving UE needs to maintain at least one RLC UM entity per transmitting peer UE, vii) An RLC UM receiver entity does not need to be configured prior to reception of the first RLC UM data unit, and viii) U-Mode is used for header compression in PDCP for ProSe Direct Communication.
- [97] FIG. 11(b) shows the protocol stack for the control plane, where RRC, RLC, MAC, and PHY sublayers (terminate at the other UE) perform the functions listed for the control plane. A D2D UE does not establish and maintain a logical connection to receiving D2D UEs prior to a D2D communication.
- [98] FIG. 12 is a conceptual diagram illustrating for a PC5 interface for ProSe Direct Discovery.
- [99] ProSe Direct Discovery is defined as the procedure used by the ProSe-enabled UE to discover other ProSe-enabled UE(s) in its proximity using E-UTRA direct radio signals via PC5.
- [100] Radio Protocol Stack (AS) for ProSe Direct Discovery is shown in FIG. 12.
- [101] The AS layer performs the following functions:
- [102] - Interfaces with upper layer (ProSe Protocol): The MAC layer receives the discovery information from the upper layer (ProSe Protocol). The IP layer is not used for transmitting the discovery information.
- [103] - Scheduling: The MAC layer determines the radio resource to be used for an-

- nouncing the discovery information received from upper layer.
- [104] - Discovery PDU generation: The MAC layer builds the MAC PDU carrying the discovery information and sends the MAC PDU to the physical layer for transmission in the determined radio resource. No MAC header is added.
- [105] There are two types of resource allocation for discovery information announcement.
- [106] - Type 1: A resource allocation procedure where resources for announcing of discovery information are allocated on a non UE specific basis, further characterized by: i) The eNB provides the UE(s) with the resource pool configuration used for announcing of discovery information. The configuration may be signalled in SIB, ii) The UE autonomously selects radio resource(s) from the indicated resource pool and announce discovery information, iii) The UE can announce discovery information on a randomly selected discovery resource during each discovery period.
- [107] - Type 2: A resource allocation procedure where resources for announcing of discovery information are allocated on a per UE specific basis, further characterized by: i) The UE in RRC_CONNECTED may request resource(s) for announcing of discovery information from the eNB via RRC, ii) The eNB assigns resource(s) via RRC, iii) The resources are allocated within the resource pool that is configured in UEs for monitoring.
- [108] For UEs in RRC_IDLE, the eNB may select one of the following options:
- [109] - The eNB may provide a Type 1 resource pool for discovery information announcement in SIB. UEs that are authorized for ProSe Direct Discovery use these resources for announcing discovery information in RRC_IDLE.
- [110] - The eNB may indicate in SIB that it supports D2D but does not provide resources for discovery information announcement. UEs need to enter RRC Connected in order to request D2D resources for discovery information announcement.
- [111] For UEs in RRC_CONNECTED,
- [112] - A UE authorized to perform ProSe Direct Discovery announcement indicates to the eNB that it wants to perform D2D discovery announcement.
- [113] - The eNB validates whether the UE is authorized for ProSe Direct Discovery announcement using the UE context received from MME.
- [114] - The eNB may configure the UE to use a Type 1 resource pool or dedicated Type 2 resources for discovery information announcement via dedicated RRC signaling (or no resource).
- [115] - The resources allocated by the eNB are valid until a) the eNB de-configures the resource(s) by RRC signaling or b) the UE enters IDLE. (FFS whether resources may remain valid even in IDLE).
- [116] Receiving UEs in RRC_IDLE and RRC_CONNECTED monitor both Type 1 and Type 2 discovery resource pools as authorized. The eNB provides the resource pool

configuration used for discovery information monitoring in SIB. The SIB may contain discovery resources used for announcing in neighbor cells as well.

[117] FIG. 13 is a conceptual diagram illustrating for Vehicle-to-Everything (V2X) communication;

[118] Referring to FIG. 13, the vehicular communication, referred to as Vehicle-to-Everything (V2X), can be divided into three different types including Vehicle-to-Vehicle (V2V) Communications, Vehicle-to-Infrastructure (V2I) Communications and Vehicle-to-Pedestrian (V2P) Communications.

[119] These three types of V2X can use “co-operative awareness” to provide more intelligent services for end-users. This means that transport entities, such as vehicles, roadside infrastructure, and pedestrians, can collect knowledge of their local environment (e.g., information received from other vehicles or sensor equipment in proximity) to process and share that knowledge in order to provide more intelligent services, such as cooperative collision warning or autonomous driving.

[120] Vehicle-to-Vehicle (V2V)

[121] E-UTRAN allows such UEs that are in proximity of each other to exchange V2V-related information using E-UTRA(N) when permission, authorisation and proximity criteria are fulfilled. The proximity criteria can be configured by the MNO. However, UEs supporting V2V Service can exchange such information when served by or not served by E-UTRAN which supports V2X Service.

[122] The UE supporting V2V applications transmits application layer information (e.g. about its location, dynamics, and attributes as part of the V2V Service). The V2V payload must be flexible in order to accommodate different information contents, and the information can be transmitted periodically according to a configuration provided by the MNO.

[123] V2V is predominantly broadcast-based; V2V includes the exchange of V2V-related application information between distinct UEs directly and/or, due to the limited direct communication range of V2V, the exchange of V2V-related application information between distinct UEs via infrastructure supporting V2X Service, e.g., RSU (road side unit), application server, etc.

[124] Vehicle-to-Infrastructure (V2I)

[125] The UE supporting V2I applications sends application layer information to RSU. RSU sends application layer information to a group of UEs or a UE supporting V2I applications.

[126] V2N is also introduced where one party is a UE and the other party is a serving entity, both supporting V2N applications and communicating with each other via LTE network.

[127] Vehicle-to-Pedestrian (V2P)

- [128] E-UTRAN allows such UEs that are in proximity of each other to exchange V2P-related information using E-UTRAN when permission, authorisation and proximity criteria are fulfilled. The proximity criteria can be configured by the MNO. However, UEs supporting V2P Service can exchange such information even when not served by E-UTRAN which supports V2X Service.
- [129] The UE supporting V2P applications transmits application layer information. Such information can be broadcast by a vehicle with UE supporting V2X Service (e.g., warning to pedestrian), and/or by a pedestrian with UE supporting V2X Service (e.g., warning to vehicle).
- [130] V2P includes the exchange of V2P-related application information between distinct UEs (one for vehicle and the other for pedestrian) directly and/or, due to the limited direct communication range of V2P, the exchange of V2P-related application information between distinct UEs via infrastructure supporting V2X Service, e.g., RSU, application server, etc.
- [131] Hereinafter, a discard procedure of a PDCP (packet data convergence protocol) SDU (service data unit) will be described.
- [132] At reception of a PDCP SDU from upper layers, the UE shall start a discardTimer associated with this PDCP SDU. Then, when the discardTimer expires for a PDCP SDU, or the successful delivery of a PDCP SDU is confirmed by PDCP status report, the UE shall discard the PDCP SDU along with the corresponding PDCP PDU. If the corresponding PDCP PDU has already been submitted to lower layers the discard is indicated to lower layers.
- [133] The discardTimer is configured by upper layers. In the transmitter, a new timer is started upon reception of an SDU from upper layer. The receiving side of each PDCP entity shall maintain the following timers only when the reordering function is used.
- [134] Hereinafter, it is described how the mechanism L2 layer (e.g. PDCP layer) discards the packets in the buffer. In the following, the invention describes about the PDCP layer behavior, however, the scope of the invention is not limited to PDCP layer.
- [135] <First Embodiment>
- [136] In the First Embodiment of the present invention, the PDCP layer discards the PDCP SDU(s) which is already in PDCP buffer even if the PDCP discard timer is still running upon detection of:
- [137] - the number of SDUs in PDCP buffer for an indicated bearer is more than (or equal to) a threshold; and/or
- [138] - The number of SDUs of the same priority/QoS/QCI value in PDCP buffer is more than (or equal to) a threshold. Here, it is assumed that PDCP SDUs having different priorities exist in one bearer.
- [139] Especially, the threshold value can be configured or fixed. Or, the threshold value

can be configured per destination. Then, PDCP entity counts the number of SDUs in the buffer as per destination and compares the threshold value associated with the destination. Further, the number SDUs in the buffer may include RLC SDUs if no segment of the RLC SDU has been mapped to a RLC data PDU yet.

[140] As a baseline, at reception of a PDCP SDU from upper layers, the UE shall start the PDCP discard timer called as discardTimer associated with this PDCP SDU. The assumption is that upper layer provides the priority/QoS/QCI information to lower layer (e.g PDCP entity) with SDU.

[141] The priority described above is a priority of a packet (e.g. PPPP (ProSe Per-Packet Priority), other priority considering priority, latency and loss rate). The QoS information can be defined by e.g. priority, latency requirement and/or loss rate. The QoS information is classified into levels. The level has an associated priority, latency requirement and/or loss rate.

[142] For the above behavior, the network configures/indicates whether the PDCP entity of the UE shall perform above behavior when the network set up a radio bearer or modifies a radio bearer configuration. If PDCP entity of the UE is allowed to perform discard behavior of the invention, the PDCP entity shall perform as described above. Otherwise, the PDCP entity behaves as legacy.

[143] The configuration information includes:

[144] - Indication on whether PDCP entity of the UE shall perform discard behavior described above,

[145] - Priority/QoS/QCI information which needs to be handled by this invention,

[146] - The threshold number of up-to-date SDU(s) to be stored (or to be transmitted) in PDCP buffer per PDCP entity,

[147] - The threshold number of up-to-date SDU(s) to be stored (or to be transmitted) in PDCP buffer per destination and per PDCP entity.

[148] A special case of the above invention is that only one (up-to-date) PDCP SDU is allowed to be stored and transmitted. In this case, the PDCP layer discards the PDCP SDU(s) which is already in PDCP buffer even if the PDCP discard timer is still running upon detection of an ingress of other SDUs of a same priority/QoS/QCI in PDCP buffer and/or an ingress of other SDUs into the indicated bearer.

[149] Consequently, according to the First Embodiment of the present application, it is suggested to enhance the discard procedure of a PDCP SDU. Specifically, when the discardTimer expires for a PDCP SDU, the successful delivery of a PDCP SDU is confirmed by PDCP status report, or ingress of another SDU(s) of the same QoS level if indicated by upper layer, the UE shall discard the PDCP SDU along with the corresponding PDCP PDU. If the corresponding PDCP PDU has already been submitted to lower layers the discard is indicated to lower layers.

[150] <Second Embodiment>

[151] Even before a discard timer associated with a particular PDCP SDU expires, it seems to be necessary to discard the SDU since the information in SDU is not valid any more.

[152] In the Second Embodiment of the present application, it is proposed of the method of discarding the transmitted SDUs/PDUs which is not transmitted yet and is in the L2 buffer. Especially, the proposed discarding method comprises steps 1) and 2) following.

[153] Step 1)

[154] Firstly, the UE detects at least one of the following events A)-E).

[155] A) The reference position changes

[156] It is assumed that multiple reference positions are provided via broadcast/dedicated signaling. The UE selects the closet reference positions among the provided multiple reference positions.

[157] B) The zone changes

[158] Zone can be defined in various ways. The examples of zones are as shown below (a)-(c):

[159] (a) A zone may be defined by multiple coordinates (e.g. four coordinates X, Y, Z, W). The coordinates are presented by latitude and longitude. The UE detects the zone to which it belongs by the position of the UE. If the UE's current position is in the certain area represented by the multiple coordinates, the UE determines that it is in the zone.

[160] (b) A zone may be defined with one reference position and length/width. The reference position is indicated by latitude and longitude. The UE detects the zone to which it belongs by the position of the UE. If the UE's current position is in the certain area represented by the multiple coordinates, the UE determines that it is in the zone.

[161] (c) A zone may be defined by multiple reference positions. Each reference position is represented by latitude and longitude. The UE selects the closet reference positions and determines that it belongs to the area of the reference position.

[162] C) The current position of the UE becomes far from the last reported position by a threshold value.

[163] D) The current speed of the UE becomes higher/less than the last reported speed by a threshold value.

[164] E) The heading (or direction) of the UE becomes different from the last reported heading by a threshold value.

[165] Especially, the current position/speed/heading of the UE can be determined within one zone or can be determined by using the number of zones through which the UE moves.

[166] Further, the threshold value for position/speed/heading is given by the dedicated/

broadcast signaling. The layer of the UE which detects the events can be RRC.

[167] Step 2)

[168] When the UE detects one of the above events, the UE (e.g. RRC layer of the UE) indicates to L2 entity that SDU/PDUs that are not transmitted yet are discarded. Then, the PDCP layer discards the PDCP SDU(s) which is already in PDCP buffer even if the PDCP discard timer is still running. The PDCP layer also indicates the RLC layer to discard unnecessary RLC SDUs in the bearer associated with the PDCP entity. When indicated from upper layer (i.e. PDCP) to discard a particular RLC SDU, the transmitting side of an AM RLC entity or the transmitting UM RLC entity shall discard the indicated RLC SDU if no segment of the RLC SDU has been mapped to a RLC data PDU yet.

[169] FIG. 14 is a flow chart illustrating an operation in accordance with an embodiment of the present invention.

[170] Referring to FIG. 14, in S1401, a specific layer entity (for example, PDCP layer entity) of the UE may receive a packet from an upper layer and store the packet in a buffer (i.e., PDCP buffer), in S1401. Preferably, the specific layer entity starts a discard timer upon receiving the packet received from the upper layer.

[171] Next, in S1403, the specific layer entity may determine whether or not a number of packets in the buffer is equal to or greater than a threshold value. Here, the threshold value may be configured by a network. Preferably, the specific layer entity may consider only packets having same priority. In this case, the specific layer entity may determine whether or not a number of packets having same priority in the buffer is equal to or greater than the threshold value.

[172] Finally, in S1405, if the number of packets (having the same priority) in the buffer is equal to or greater than the threshold value, or if the discard timer is expired, or if the packet is delivered successfully to a lower layer, the specific layer entity should discard the packet. If the threshold value is 1, the packet may be discarded upon a detection of ingress of another packet into the buffer.

[173] Additionally, the specific layer entity may determine whether a zone in which the UE is located is changed or not. In this case, when the zone is changed, the packet may be discarded in spite of other conditions such as the number of packets in the buffer or the discard timer.

[174] FIG. 15 is a block diagram illustrating a communication apparatus in accordance with an embodiment of the present invention.

[175] Referring to FIG. 15, a communication device 1500 includes a processor 1510, a memory 1520, a Radio Frequency (RF) module 1530, a display module 1540, and a user interface module 1550.

[176] The communication device 1500 is illustrated for convenience of the description and

some modules may be omitted. Moreover, the communication device 1500 may further include necessary modules. Some modules of the communication device 1500 may be further divided into sub-modules. The processor 1510 is configured to perform operations according to the embodiments of the present invention exemplarily described with reference to the figures. Specifically, for the detailed operations of the processor 1510, reference may be made to the contents described with reference to FIGs. 1 to 14.

[177] The memory 1520 is connected to the processor 1510 and stores operating systems, applications, program code, data, and the like. The RF module 1530 is connected to the processor 1510 and performs a function of converting a baseband signal into a radio signal or converting a radio signal into a baseband signal. For this, the RF module 1530 performs analog conversion, amplification, filtering, and frequency upconversion or inverse processes thereof. The display module 1540 is connected to the processor 1510 and displays various types of information. The display module 1540 may include, but is not limited to, a well-known element such as a Liquid Crystal Display (LCD), a Light Emitting Diode (LED), or an Organic Light Emitting Diode (OLED). The user interface module 1550 is connected to the processor 1510 and may include a combination of well-known user interfaces such as a keypad and a touchscreen.

[178] The above-described embodiments are combinations of elements and features of the present invention in a predetermined manner. Each of the elements or features may be considered selective unless otherwise mentioned. Each element or feature may be practiced without being combined with other elements or features. Further, an embodiment of the present invention may be constructed by combining parts of the elements and/or features. Operation orders described in embodiments of the present invention may be rearranged. Some constructions of any one embodiment may be included in another embodiment and may be replaced with corresponding constructions of another embodiment. In the appended claims, it will be apparent that claims that are not explicitly dependent on each other can be combined to provide an embodiment or new claims can be added through amendment after the application is filed.

[179] The embodiments according to the present invention can be implemented by various means, for example, hardware, firmware, software, or combinations thereof. In the case of a hardware configuration, the embodiments of the present invention may be implemented by one or more Application Specific Integrated Circuits (ASICs), Digital Signal Processors (DSPs), Digital Signal Processing Devices (DSPDs), Programmable Logic Devices (PLDs), Field Programmable Gate Arrays (FPGAs), processors, controllers, microcontrollers, microprocessors, etc.

[180] In the case of a firmware or software configuration, the method according to the embodiments of the present invention may be implemented by a type of a module, a

procedure, or a function, which performs functions or operations described above. For example, software code may be stored in a memory unit and then may be executed by a processor. The memory unit may be located inside or outside the processor to transmit and receive data to and from the processor through various well-known means.

[181] The present invention may be carried out in other specific ways than those set forth herein without departing from the spirit and essential characteristics of the present invention. The above embodiments are therefore to be construed in all aspects as illustrative and not restrictive. The scope of the invention should be determined by the appended claims and their legal equivalents and all changes coming within the meaning and equivalency range of the appended claims are intended to be embraced therein.

Industrial Applicability

[182] While the above-described method for managing packets for a V2X (Vehicle-to-Everything) communication has been described centering on an example applied to the 3GPP LTE system, the present invention is applicable to a variety of wireless communication systems in addition to the 3GPP LTE system.

[183]

Claims

- [Claim 1] A method for discarding at least one packet by a user equipment (UE) in a wireless communication system, the method comprising:
storing the at least one packet received from an upper layer in a buffer;
determining whether or not a number of packets in the buffer is equal to or greater than a threshold value; and
discarding the at least one packet from the buffer when the number of packets in the buffer is equal to or greater than the threshold value.
- [Claim 2] The method of claim 1, wherein determining comprises determining whether or not a number of packets having same priority in the buffer is equal to or greater than the threshold value.
- [Claim 3] The method of claim 1, further comprising receiving information about the threshold value from a network,
wherein the threshold value is configured per bearer.
- [Claim 4] The method of claim 1, further comprising:
starting a discard timer upon receiving the at least one packet received from the upper layer; and
discarding the at least one packet from the buffer when the discard timer is expired or the at least one packet is delivered successfully to a lower layer.
- [Claim 5] The method of claim 1, wherein, if the threshold value is 1, the at least one packet is discarded upon a detection of ingress of another packet into the buffer.
- [Claim 6] The method of claim 1, further comprising:
determining whether a zone in which the UE is located is changed or not; and
discarding the at least one packet from the buffer when the zone is changed.
- [Claim 7] A user equipment (UE) in a wireless communication system, the UE comprising:
a radio frequency (RF) unit; and
a processor connected with the RF unit and configured to store the at least one packet received from an upper layer in a buffer, determine whether or not a number of packets in the buffer is equal to or greater than a threshold value, and discard the at least one packet from the buffer when the number of packets in the buffer is equal to or greater than the threshold value.

- [Claim 8] The UE of claim 7, wherein the processor is configured to determine whether or not a number of packets having same priority in the buffer is equal to or greater than the threshold value.
- [Claim 9] The UE of claim 7, wherein information about the threshold value is received from a network,
wherein the threshold value is configured per bearer.
- [Claim 10] The UE of claim 7, wherein the processor is further configured to start a discard timer upon receiving the at least one packet received from the upper layer, and discard the at least one packet from the buffer when the discard timer is expired or the at least one packet is delivered successfully to a lower layer.
- [Claim 11] The UE of claim 7, wherein if the threshold value is 1, the at least one packet is discarded upon a detection of ingress of another packet into the buffer.
- [Claim 12] The UE of claim 7, wherein the processor is configured to determine whether a zone in which the UE is located is changed or not, and discard the at least one packet from the buffer when the zone is changed.

[Fig. 1]

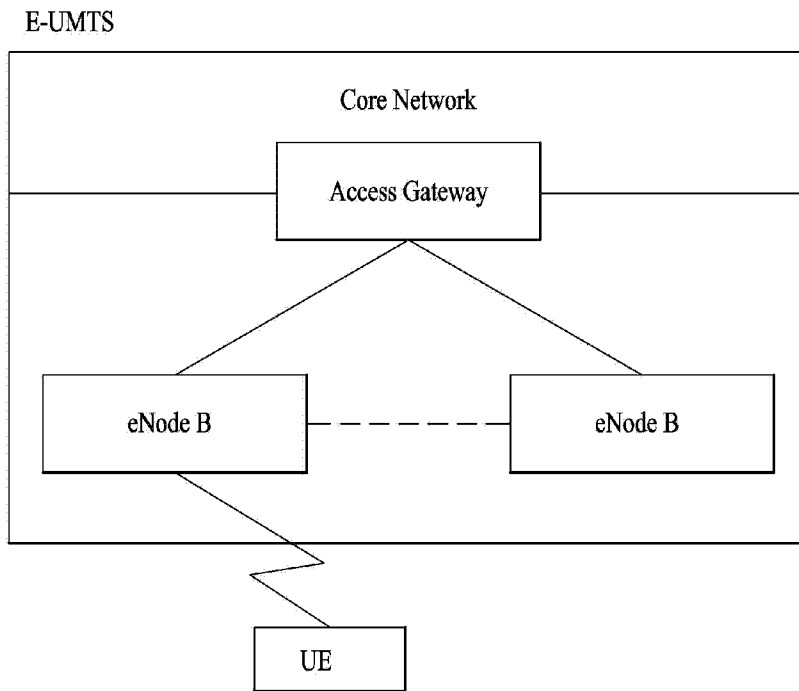

[Fig. 2]

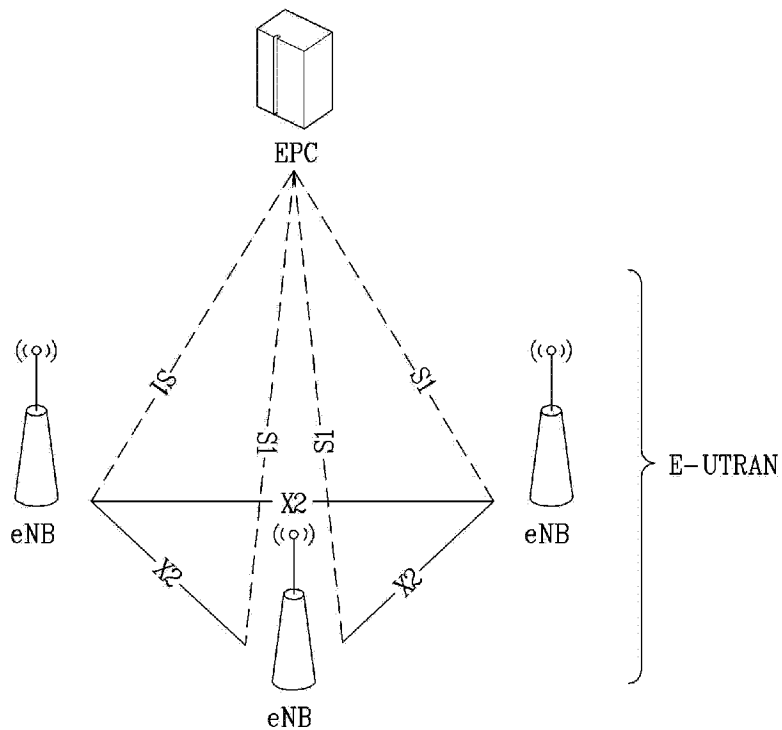

[Fig. 3]

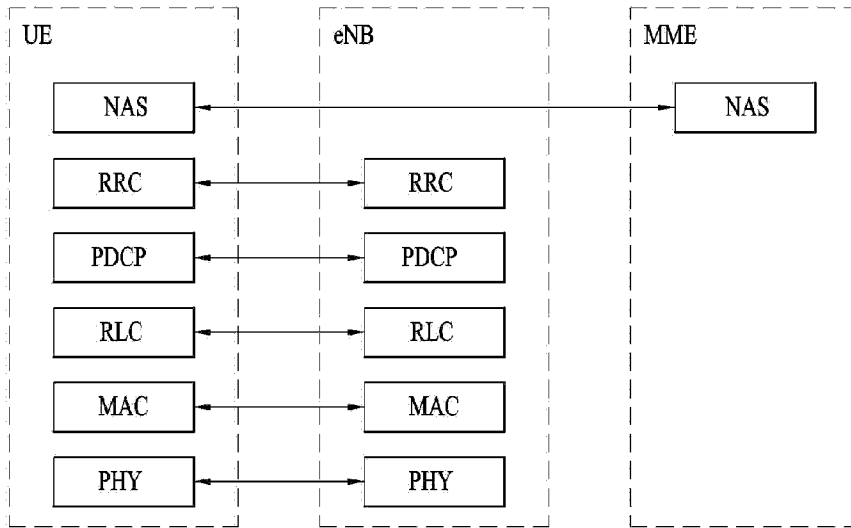

(A) Control-plane protocol stack

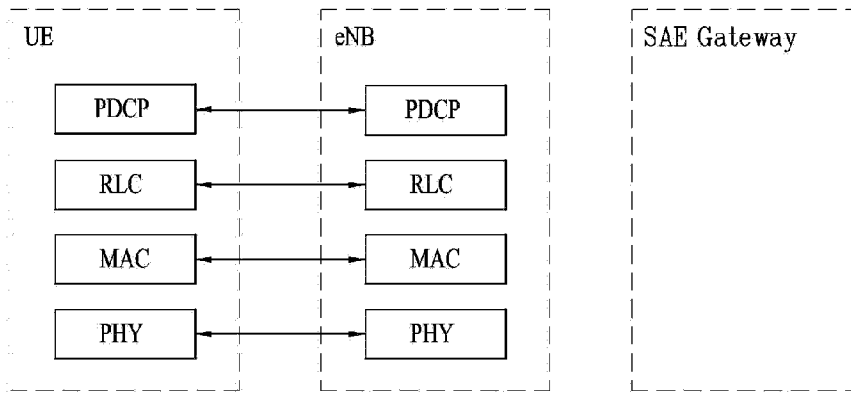

(B) User-plane protocol stack

[Fig. 4]

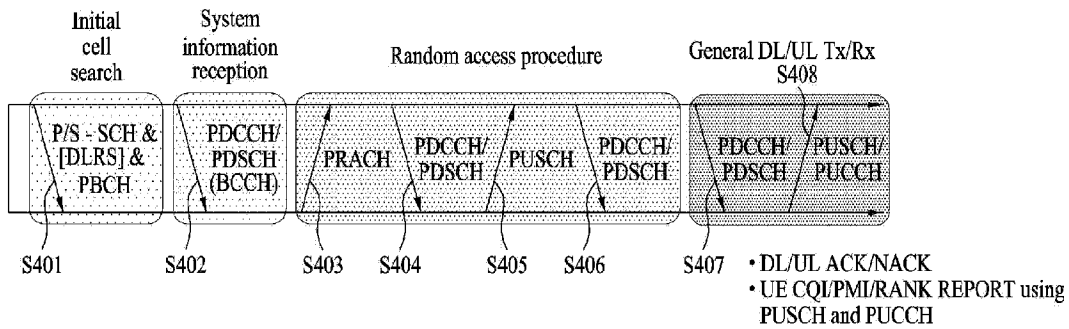

[Fig. 5]

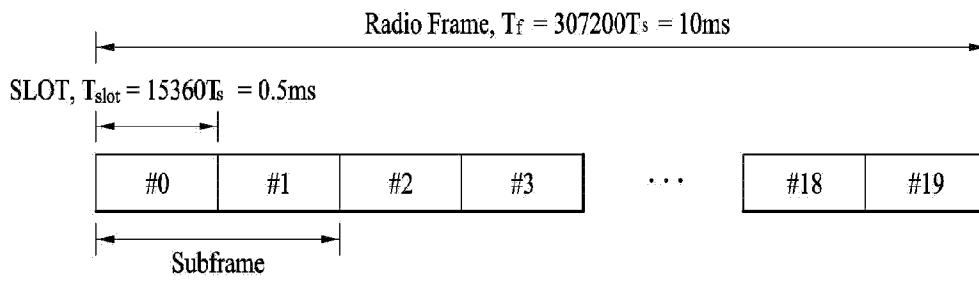

[Fig. 6]

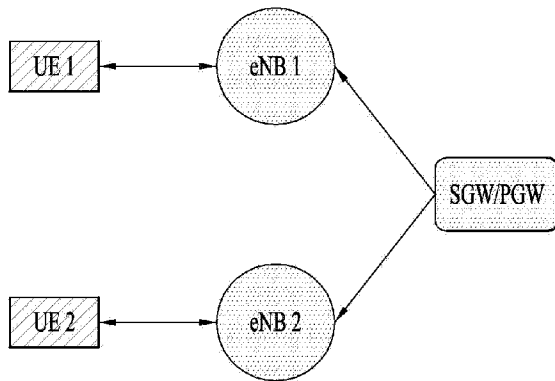

[Fig. 7]

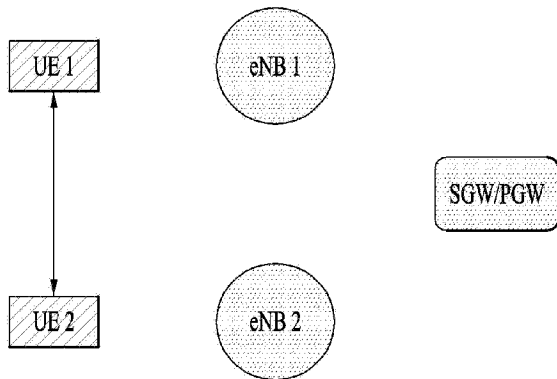

[Fig. 8]

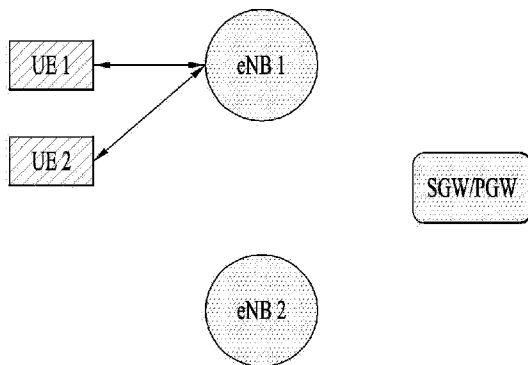

[Fig. 9]

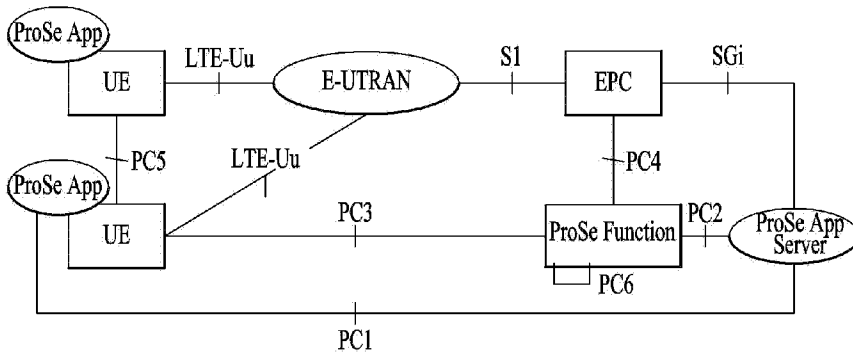

[Fig. 10]

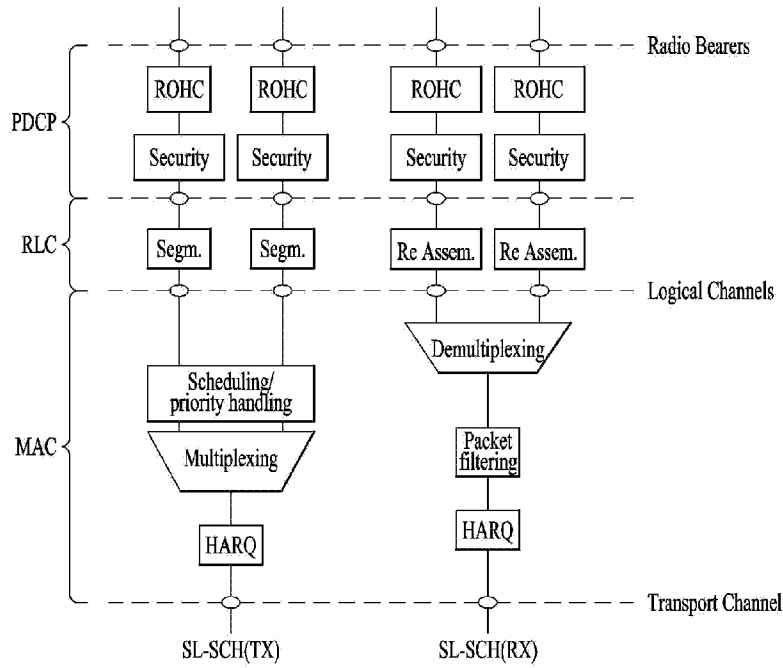

[Fig. 11]

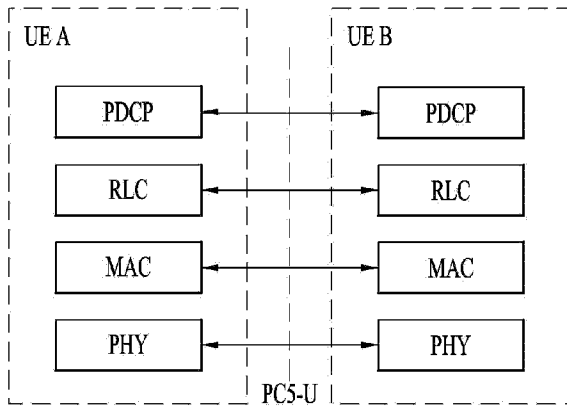

(a)

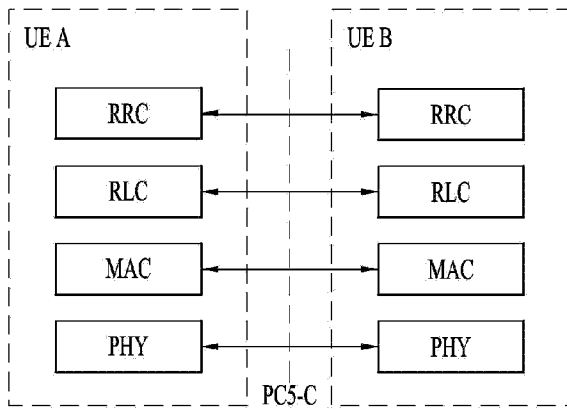

(b)

[Fig. 12]

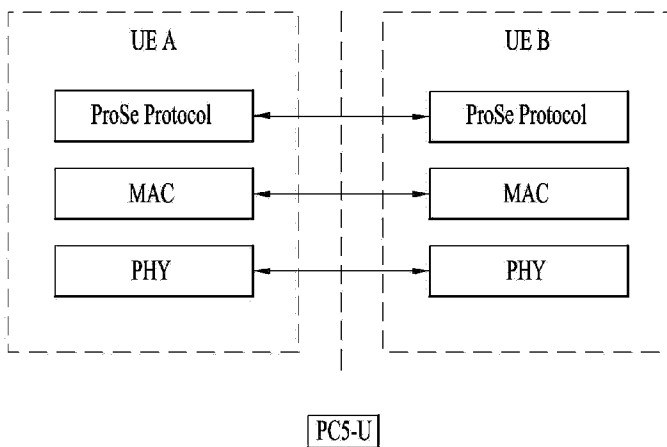

[Fig. 13]

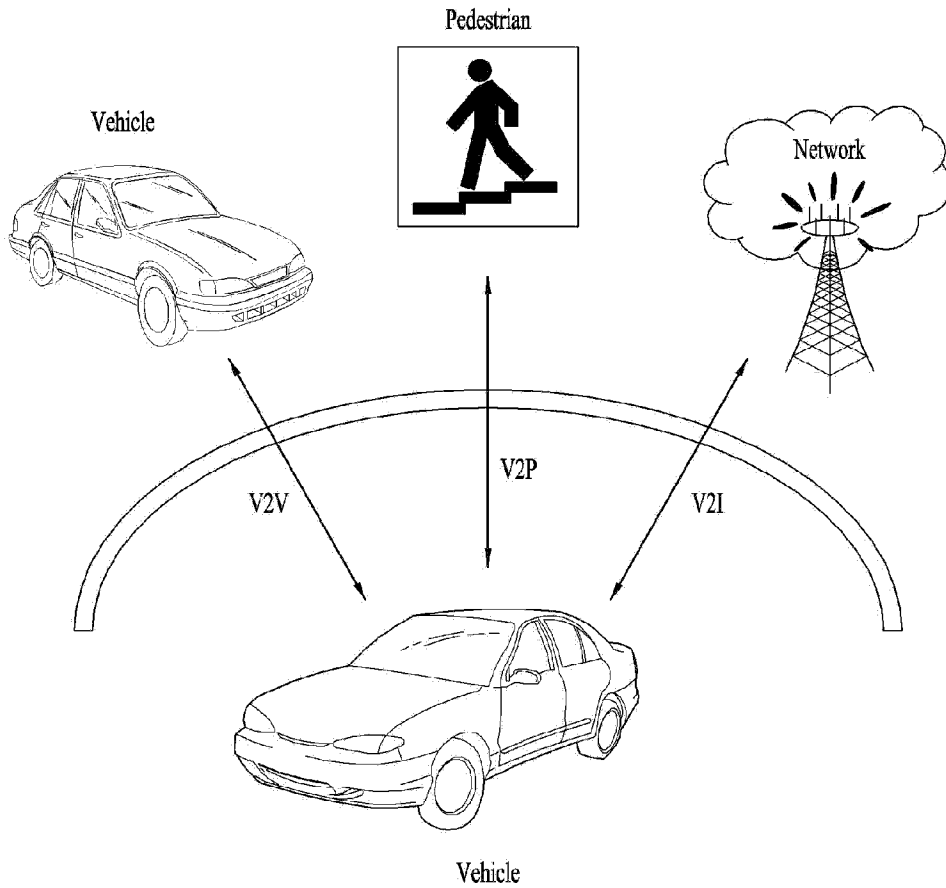

[Fig. 14]

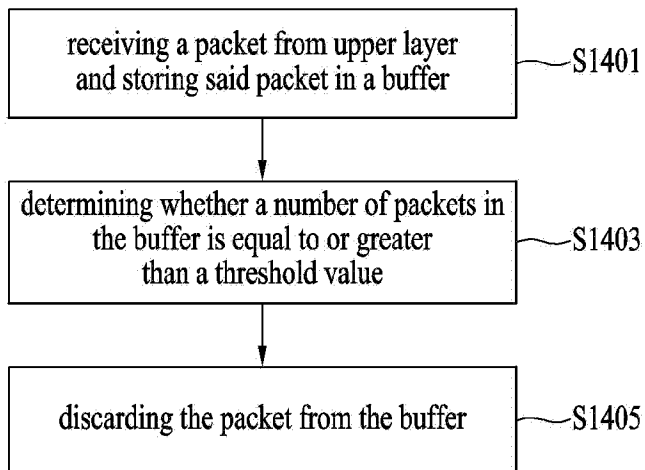

[Fig. 15]

