

(19)



(11)

EP 3 095 752 A1

(12)

EUROPEAN PATENT APPLICATION
published in accordance with Art. 153(4) EPC

(43) Date of publication:

23.11.2016 Bulletin 2016/47

(51) Int Cl.:

B66F 3/25 *(2006.01)*

(21) Application number: **15730039.3**

(86) International application number:

PCT/CN2015/076874

(22) Date of filing: **17.04.2015**

(87) International publication number:

WO 2016/149968 (29.09.2016 Gazette 2016/39)

(84) Designated Contracting States:

**AL AT BE BG CH CY CZ DE DK EE ES FI FR GB
GR HR HU IE IS IT LI LT LU LV MC MK MT NL NO
PL PT RO RS SE SI SK SM TR**

Designated Extension States:

BA ME

Designated Validation States:

MA

(72) Inventors:

- **CHEN, Jiang**
Suzhou
Jiangsu 215000 (CN)
- **YE, Junxue**
Suzhou
Jiangsu 215000 (CN)
- **WANG, Jingfang**
Suzhou
Jiangsu 215000 (CN)

(30) Priority: **23.03.2015 CN 201511278517**

(71) Applicant: **Changshu Tongrun Auto Accessory Co., Ltd.**

Changshu economic development zone
Suzhou
Jiangsu (CN)

(74) Representative: **Arpe Fernandez, Manuel de**

Guzmán el Bueno, 133
(Edificio Germania)
28003 Madrid (ES)

(54) **OIL RETURNING STRUCTURE**

(57) An oil return mechanism includes a base, a control switch, a first blocking ball mounted in the base, an elastic member mounted between the first blocking ball and the base. The base has a liquid storing cavity, a liquid returning cavity, a communicating cavity, a first communicating opening communicating between the liquid returning cavity and the communicating cavity, and a second communicating opening communicating between the communicating cavity and the liquid storing cavity. The control switch is adapted for controlling the second communicating opening open or closed so that the communicating cavity and the liquid storing cavity are connected or separated. The first blocking ball moves be-

tween a blocking position and an open position. The first communicating opening is positioned in a communicating portion of the base. When the first blocking ball is in the blocking position, one or more liquid guiding gaps are formed between the first blocking ball and an inner wall of the communicating portion of the base. The liquid guiding gap communicates between the liquid returning cavity and the communicating cavity. The present invention can regulate a speed of a fluid flowing from the liquid returning cavity to the communicating cavity, and has the advantages of simple structure and great reduction of cost.

EP 3 095 752 A1

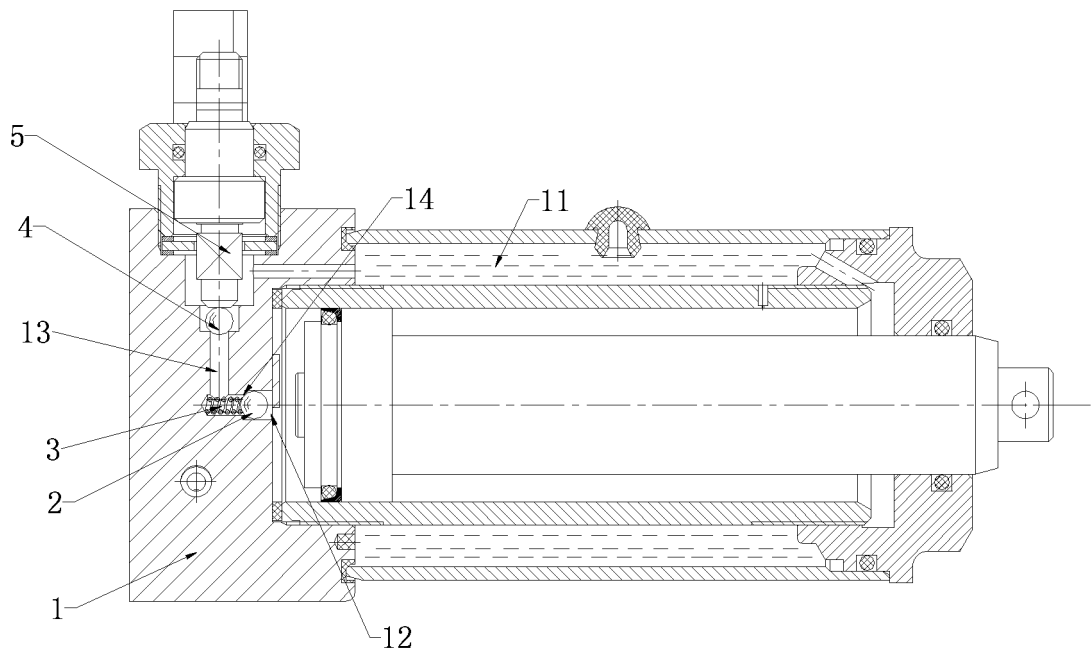

Description

TECHNICAL FIELD

[0001] The present invention relates to an oil return mechanism.

BACKGROUND

[0002] A jack is generally configured with an oil return mechanism. A conventional oil return mechanism includes a liquid storing cavity, a liquid returning cavity, and a communicating cavity communicating between the liquid storing cavity and the liquid returning cavity. The communicating cavity is configured with a control switch for selectively conducting the on-off control of the communicating cavity. A speed of a fluid flowing from the liquid returning cavity to the communicating cavity has a direct impact on a descending speed of the jack in operation. However, when the control switch is on, the speed of the fluid flowing from the liquid returning cavity to the communicating cavity remains stable, and thus the jack descends rapidly either in a no load condition or in a load condition, which may result in accidents, for instance, a lifting load rapidly falling down from the operating jack to hurt an operator. Therefore, the conventional oil return mechanism is configured with a speed regulating device for regulating the speed of the fluid flowing from the liquid returning cavity to the communicating cavity in accordance with the different operation condition of the jack. However, the expensive speed regulating device adds significant cost to the oil return mechanism, and thus the oil return mechanism fails to satisfy industrial requires.

SUMMARY OF THE INVENTION

[0003] To overcome the defects described above, the present invention provides an oil return mechanism which can regulate a speed of a fluid flowing from a liquid returning cavity to the communicating cavity, and reduce costs efficiently.

[0004] Some embodiments of the present invention refer to:

[0005] An oil return mechanism, comprising:

a base, a control switch, a first blocking ball mounted in the base, an elastic member mounted between the first blocking ball and the base; wherein the base has a liquid storing cavity, a liquid returning cavity, a communicating cavity, a first communicating opening communicating between the liquid returning cavity and the communicating cavity, and a second communicating opening communicating between the communicating cavity and the liquid storing cavity; the control switch is adapted for controlling the second communicating opening open or closed so that the communicating cavity and the liquid storing cavity are connected or separated; the first blocking ball

moves between a blocking position and an open position with an external force; when the first blocking ball is in the open position, the whole first communicating opening is open, and thus a fluid flows from the liquid returning cavity to the communicating cavity; the first communicating opening is positioned in a communicating portion of the base; when the first blocking ball is in the blocking position, one or more liquid guiding gaps are formed between the first blocking ball and the communicating portion of the base; and the liquid guiding gap communicates between the liquid returning cavity and the communicating cavity.

[0006] The control switch includes a second blocking ball mounted in the base and a valve rod; the valve rod is adapted for pushing the second blocking ball in a sealing position for sealing the second communicating opening; and the valve rod is threadly coupled to the base.

[0007] An end of the elastic member is mounted in the communicating cavity, and the other end of the elastic member is positioned against the first blocking ball.

[0008] The first blocking ball moves between the blocking position and the open position under the cooperative control of an elastic force of the elastic member and a hydraulic pressure of the liquid in the liquid returning cavity.

[0009] The open position is positioned in an end of the liquid returning cavity adjacent to the first communicating opening, and a diameter of the end of the liquid returning cavity is larger than the one of the first blocking ball.

[0010] The elastic force generated by the elastic member acts on the first blocking ball from the blocking position to the open position.

[0011] The elastic member is a spring.

[0012] A plurality of liquid guiding gaps is formed between the first blocking ball and the communicating portion of the base.

[0013] Beneficial effects of the present invention are as follows:

In use, when the first blocking ball moves to the open position or the blocking position, the fluid can flow to the communicating cavity through the second communicating cavity or the liquid guiding gap, to reduce the amount of the flowing liquid, and thus regulate the speed of the fluid flowing from the liquid returning cavity to the communicating cavity. Moreover, the present invention has the advantages of simple structure, convenient manufacture and great reduction of cost. The liquid guiding gap formed between the first blocking ball and an inner wall of the communicating portion has an advantage of avoiding clogging.

BRIEF DESCRIPTION OF THE DRAWINGS

[0014]

FIG. 1 is a construction schematic diagram of the present invention;
 FIG. 2 shows a first blocking ball positioned in an open position.
 FIG. 3 shows the second blocking ball positioned in a blocking position.
 FIG. 4 is a construction schematic diagram of another embodiment of the present invention.

Reference numbers in the drawings are as follow:

[0015]

1, base; 11, liquid storing cavity; 12, liquid returning cavity; 13, communicating cavity; 14, first communicating opening; 15, liquid guiding gap; 2, first blocking ball; 3, elastic member; 4, second blocking ball; and 5, valve rod.

DETAILED DESCRIPTION OF THE PREFERRED EMBODIMENTS

[0016] Referring to the FIG. 1 to FIG. 3, an oil return mechanism includes a base 1, a control switch; a first blocking ball 2 mounted in the base 1, an elastic member 3 mounted between the first blocking ball 2 and the base 1. The base 1 has a liquid storing cavity 11, a liquid returning cavity 12, a communicating cavity 13, a first communicating opening 14 communicating between the liquid returning cavity 12 and the communicating cavity 13, and a second communicating opening communicating between the communicating cavity 13 and the liquid storing cavity 11. The control switch is adapted for controlling the second communicating opening open or closed so that the communicating cavity 13 and the liquid storing cavity 11 are connected or separated. The first blocking ball 2 moves between a blocking position and an open position with an external force. When the first blocking ball 2 is in the open position, the whole first communicating opening 14 is open, and thus a fluid flows from the liquid returning cavity 12 to the communicating cavity 13. The first communicating opening 14 is positioned in a communicating portion of the base 1. When the first blocking ball 2 is in the blocking position, one or more liquid guiding gaps 15 are formed between the first blocking ball 2 and the communicating portion of the base 1. The liquid guiding gap 15 communicates between the liquid returning cavity 12 and the communicating cavity 13.

[0017] In use, when the first blocking ball 2 is in an open position, a fluid flows from the liquid returning cavity 12 to the communicating cavity 13 through the first communicating opening 14. When the first blocking ball 2 is in the blocking position, the fluid flows from the liquid returning cavity 12 to the communicating cavity 13 through the liquid guiding gap 15, which can reduce the amount of the flowing liquid. Therefore, the speed of the fluid flowing from the liquid returning cavity 12 to the communicating cavity 13 can be regulated by the movement of the first blocking ball 2. When the jack is in operation and no-load, the first blocking ball 2 is in the open position, and the liquid flows from the liquid returning cavity 12 to the communicating cavity 13 through the first communicating opening 14, so that the jack slows down rapidly. When the jack is on load, the first blocking ball 2 is in the blocking position; the fluid can only flows to the communicating cavity 13 through the liquid guiding gap 15. The liquid guiding gap 15 can reduce the amount of the flowing liquid, thus the fluid slows down, and the jack descends slowly. The present invention has the advantages of simple structure, convenient manufacture and great reduction of cost. The liquid guiding gap 15 has an advantage of avoiding clogging.

[0018] The liquid guiding gap 15 can be manufactured as follows. A sealing surface in the communicating portion is made firstly, and the sealing surface matches the first blocking ball 2. Secondly, a recess in the sealing surface is made so that the first communicating opening 14 is not completely sealed when the first blocking ball is in the blocking position. In other embodiments, the first blocking ball 2 may be irregular shape so that the first communicating opening 14 is not completely sealed. The size of the liquid guiding gap 15 has a direct impact on the speed of the returning fluid in the blocking position, and can be set as requirements. The amount of the liquid guiding gap 15 can be set as requirements, such as one or more.

[0019] Specifically, an end of the elastic member 3 is mounted in the communicating cavity 3, and the other end of the elastic member 3 is positioned against the first blocking ball 2, which is convenient for assembling.

[0020] The first blocking ball 2 moves between the blocking position and the open position with the external force, such as hydraulic pressure. Preferably, the first blocking ball 2 moves between the blocking position and the open position under the cooperative control of an elastic force of the elastic member 3 and the hydraulic pressure of the liquid in the liquid returning cavity 12. Specifically, the open position is positioned in an end of the liquid returning cavity 12 adjacent to the first communicating opening 14, and a diameter of the end of the liquid returning cavity 12 is larger than the one of the first blocking ball 2.

[0021] The elastic force generated by the elastic member acts on the first blocking ball 2 from the blocking position to the open position. That is to say, the elastic member 3 is in a compressed state when the first blocking ball 2 is in the blocking position. The elastic member 3 generates a force on the first blocking ball 2 towards the open position when the elastic member 3 is released. The liquid in the liquid returning cavity 12 generates a force on the first blocking ball 2 from the open position to the blocking position.

[0022] Preferably, the elastic member 3 may be a spring or an elastic ring.

[0023] The control switch includes a second blocking

ball 4 mounted in the base 1 and a valve rod 5. The valve rod 5 is adapted for pushing the second blocking ball 4 in a sealing position for sealing the second communicating opening. The valve rod 5 is threadably coupled to the base 1. The simplification of the control switch can reduce costs. In use, the valve rod 5 pushes the second blocking ball 4 in the sealing position so that the second communicating opening is sealed. The valve rod 5 is screwed to release the second blocking ball 4, and the fluid pushes the second blocking ball 4 upwards so that the second communicating opening is open.

[0024] In actual design, the liquid returning cavity 12 is generally configured with a piston. The moving speed of the piston is controlled by the fluid flowing from the liquid returning cavity 12, and thus the descending speed of the jack is controlled by the piston.

[0025] In actual use, when the jack is no load, the valve rod 5 is screwed to release the second blocking ball 4. The first blocking ball 2 moves to the open position when the elastic force of the spring is larger than the hydraulic pressure of the hydraulic oil in the liquid returning cavity 12. The hydraulic oil flows from the liquid returning cavity 12 to the communicating cavity 13 through the first communicating opening 14 (referred to the arrow direction in FIG. 2), and further goes through the communicating cavity 13 to push the second blocking ball 4 upwards, and then flows into the liquid storing cavity 11. When the jack is on load, the valve rod 5 is screwed to release the blocking ball 4. The first blocking ball 2 is in blocking position when the elastic force of the spring is smaller than the hydraulic pressure of the hydraulic oil in the liquid returning cavity 12. The hydraulic oil flows into the communicating cavity 13 through the liquid guiding gap 15 (referred to the arrow direction in FIG. 3), and pushes the second blocking ball 4 upwards, and then flows into the liquid returning cavity 11. Therefore, the jack slows down.

[0026] Fig. 4 shows a construction schematic diagram of a second embodiment of the present invention. The difference between the FIG. 4 and the FIG. 1 is the installation how the valve rod 5 coupled to the base 1. In FIG. 1, the valve rod 5 is vertically and threadably coupled to the base 1. In FIG. 4, the valve rod 5 is obliquely and threadably coupled to the base 1. The installation how the valve rod 5 coupled to the base 1 is not limited only if the valve 5 can push the second blocking ball 4.

[0027] Various modifications could be made to the embodiments by those of ordinary skill in the art without departing from the true spirit and scope of the disclosure. And those modified embodiments are covered by the claims of the disclosure.

Claims

1. An oil return mechanism, comprising:
 - a base, a control switch, a first blocking ball mounted in the base, an elastic member mount-

ed between the first blocking ball and the base; wherein the base has a liquid storing cavity, a liquid returning cavity, a communicating cavity, a first communicating opening communicating between the liquid returning cavity and the communicating cavity, and a second communicating opening communicating between the communicating cavity and the liquid storing cavity; the control switch is adapted for controlling the second communicating opening open or closed so that the communicating cavity and the liquid storing cavity are connected or separated; the first blocking ball moves between a blocking position and an open position with an external force; when the first blocking ball is in the open position, the whole first communicating opening is open, and thus a fluid flows from the liquid returning cavity to the communicating cavity; the first communicating opening is positioned in a communicating portion of the base; when the first blocking ball is in the blocking position, one or more liquid guiding gaps are formed between the first blocking ball and the communicating portion of the base; and the liquid guiding gap communicates between the liquid returning cavity and the communicating cavity.

2. The oil return mechanism of claim 1, wherein the control switch includes a second blocking ball mounted in the base and a valve rod; the valve rod is adapted for pushing the second blocking ball in a sealing position for sealing the second communicating opening; and the valve rod is threadably coupled to the base.
3. The oil return mechanism of claim 1, wherein an end of the elastic member is mounted in the communicating cavity, and the other end of the elastic member is positioned against the first blocking ball.
4. The oil return mechanism of claim 1, wherein the first blocking ball moves between the blocking position and the open position under the cooperative control of an elastic force of the elastic member and a hydraulic pressure of the liquid in the liquid returning cavity.
5. The oil return mechanism of claim 4, wherein the open position is positioned in an end of the liquid returning cavity adjacent to the first communicating opening, and a diameter of the end of the liquid returning cavity is larger than the one of the first blocking ball.
6. The oil return mechanism of claim 4 or 5, wherein the elastic force generated by the elastic member acts on the first blocking ball from the blocking position to the open position.

7. The oil return mechanism of claim 1, wherein the elastic member is a spring.
8. The oil return mechanism of claim 1, wherein a plurality of liquid guiding gaps is formed between the first blocking ball and the communicating portion of the base.

10

15

20

25

30

35

40

45

50

55

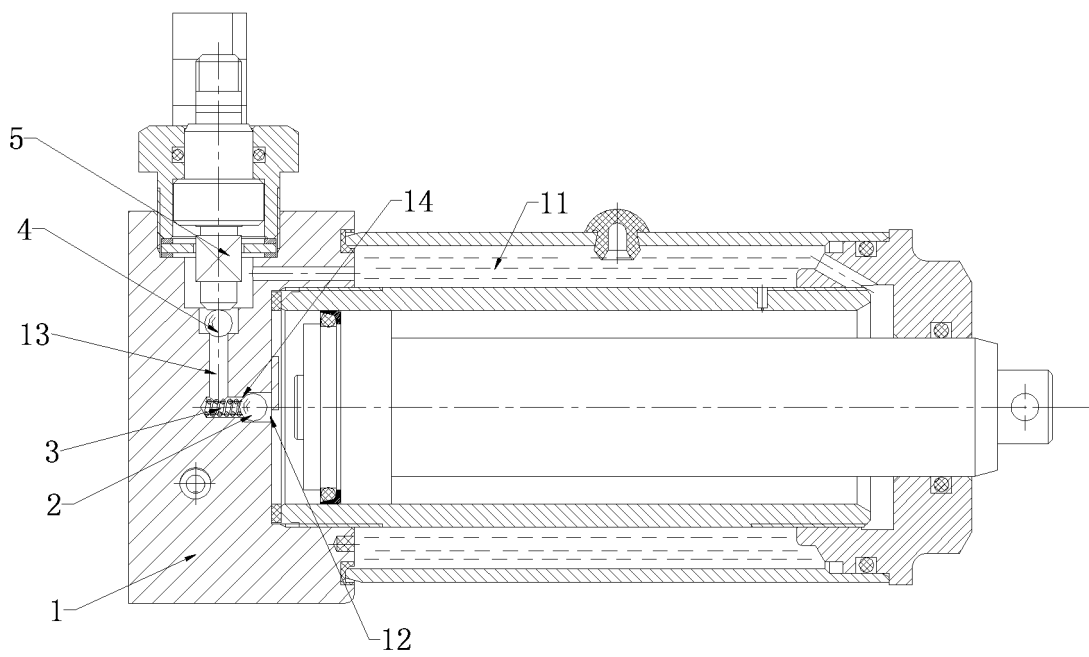

FIG. 1

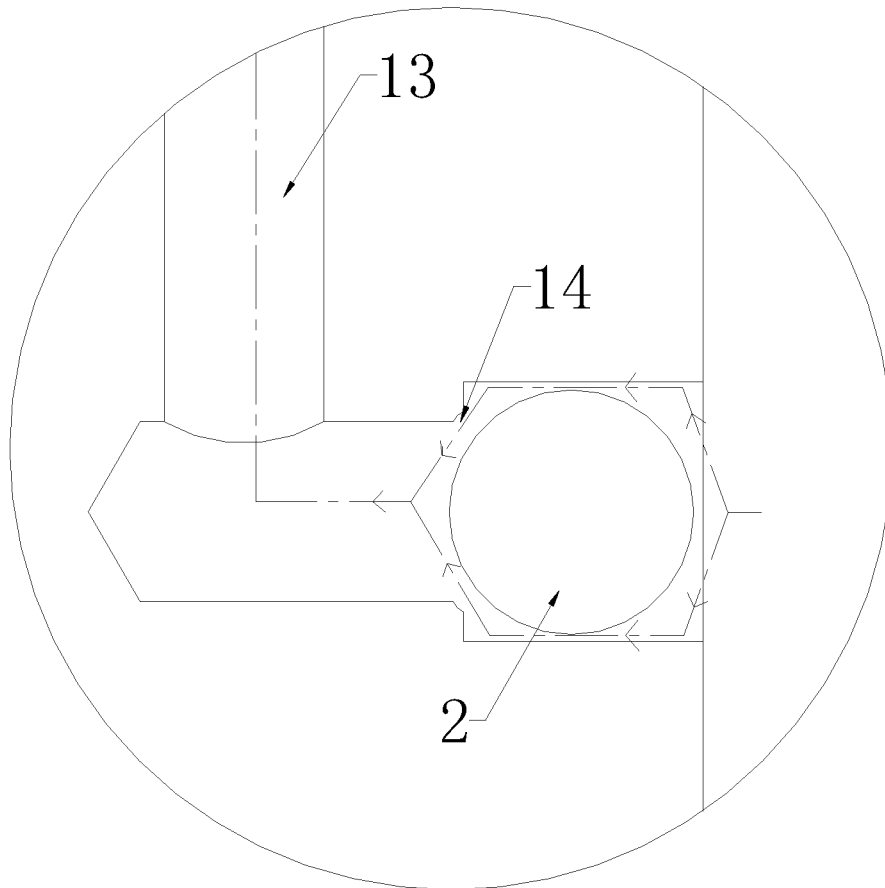

FIG. 2

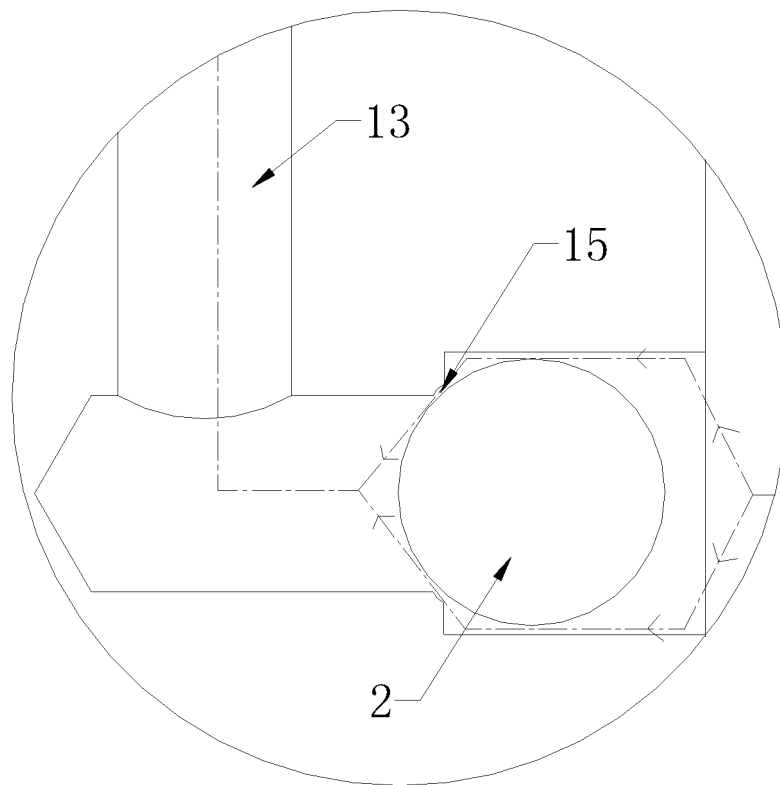

FIG.3

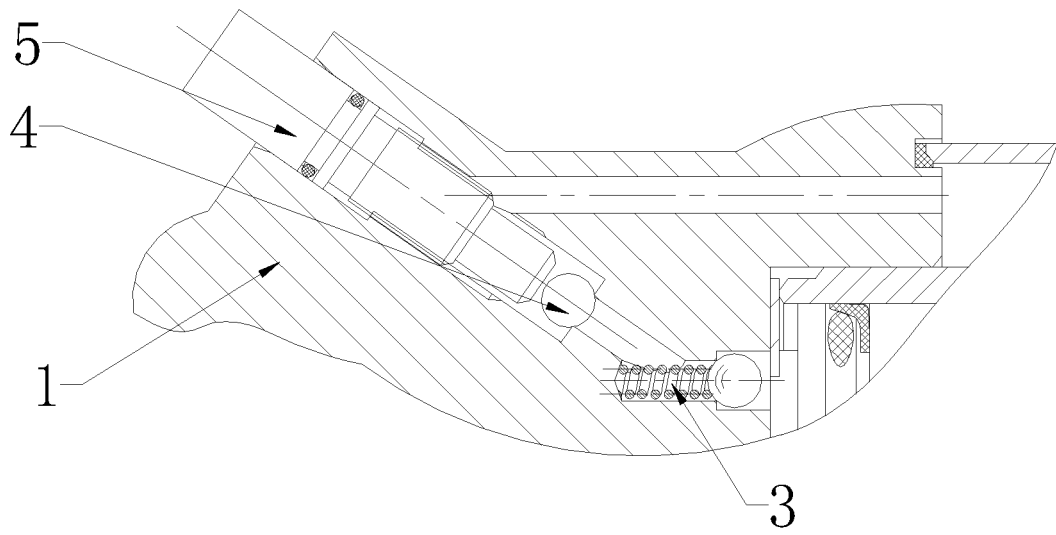

FIG.4

INTERNATIONAL SEARCH REPORT

International application No.

PCT/CN2015/076874

A. CLASSIFICATION OF SUBJECT MATTER

B66F 3/25 (2006.01) i

According to International Patent Classification (IPC) or to both national classification and IPC

B. FIELDS SEARCHED

Minimum documentation searched (classification system followed by classification symbols)

B66F

Documentation searched other than minimum documentation to the extent that such documents are included in the fields searched

Electronic data base consulted during the international search (name of data base and, where practicable, search terms used)

CNPAT, CNKI, WPI, EPODOC: ball, bead, valve, slow, speed

C. DOCUMENTS CONSIDERED TO BE RELEVANT

Category*	Citation of document, with indication, where appropriate, of the relevant passages	Relevant to claim No.
PX	CN 104692279 A (CHANGSHU TONGRUN AUTO ACCESSORY CO., LTD.), 10 June 2015 (10.06.2015), claims 1-8	1-8
PX	CN 204508678 U (CHANGSHU TONGRUN AUTO ACCESSORY CO., LTD.), 29 July 2015 (29.07.2015), claims 1-8	1-8
A	CN 102225713 A (CHANGSHU TONGRUN AUTO ACCESSORY CO., LTD.), 26 October 2011 (26.10.2011), description, paragraphs 0023-0029, and figure 2	1-8
A	CN 102052357 A (CHANGSHU TONGRUN AUTO ACCESSORY CO., LTD.), 11 May 2011 (11.05.2011), the whole document	1-8
A	CN 202193586 U (CHANGSHU TONGRUN AUTO JACK CO., LTD.), 18 April 2012 (18.04.2012), the whole document	1-8
A	US 8523145 B2 (ACTUANT CORP et al.), 03 September 2013 (03.09.2013), the whole document	1-8

 Further documents are listed in the continuation of Box C. See patent family annex.

* Special categories of cited documents:	“T” later document published after the international filing date or priority date and not in conflict with the application but cited to understand the principle or theory underlying the invention
“A” document defining the general state of the art which is not considered to be of particular relevance	“X” document of particular relevance; the claimed invention cannot be considered novel or cannot be considered to involve an inventive step when the document is taken alone
“E” earlier application or patent but published on or after the international filing date	“Y” document of particular relevance; the claimed invention cannot be considered to involve an inventive step when the document is combined with one or more other such documents, such combination being obvious to a person skilled in the art
“L” document which may throw doubts on priority claim(s) or which is cited to establish the publication date of another citation or other special reason (as specified)	“&” document member of the same patent family
“O” document referring to an oral disclosure, use, exhibition or other means	
“P” document published prior to the international filing date but later than the priority date claimed	

Date of the actual completion of the international search 19 November 2015 (19.11.2015)	Date of mailing of the international search report 15 December 2015 (15.12.2015)
Name and mailing address of the ISA/CN: State Intellectual Property Office of the P. R. China No. 6, Xitucheng Road, Jimenqiao Haidian District, Beijing 100088, China Facsimile No.: (86-10) 62019451	Authorized officer YAN, Zhou Telephone No.: (86-10) 62085299

INTERNATIONAL SEARCH REPORT

International application No.

PCT/CN2015/076874

5

C (Continuation). DOCUMENTS CONSIDERED TO BE RELEVANT

10

15

20

25

30

35

40

45

50

55

Category*	Citation of document, with indication, where appropriate, of the relevant passages	Relevant to claim No.
A	US 6923431 B2 (SHINN FU CORP.), 02 August 2005 (02.08.2005), the whole document	1-8
A	US 7421841 B2 (SHINN FU CORP.), 09 September 2008 (09.09.2008), the whole document	1-8

INTERNATIONAL SEARCH REPORT
 Information on patent family members

International application No.
PCT/CN2015/076874

5
10
15
20
25
30
35
40
45
50
55

Patent Documents referred in the Report	Publication Date	Patent Family	Publication Date
CN 104692279 A	10 June 2015	None	
CN 204508678 U	29 July 2015	None	
CN 102225713 A	26 October 2011	CN 102225713 B	07 November 2012
CN 102052357 A	11 May 2011	None	
CN 202193586 U	18 April 2012	None	
US 8523145 B2	03 September 2013	US 2010252791 A1	07 October 2010
US 6923431 B2	02 August 2005	US 2005062027 A1	24 March 2005
US 7421841 B2	09 September 2008	US 2005226744 A1	13 October 2005