



US00RE38854E

(19) **United States**
(12) **Reissued Patent**
Nakashiba et al.

(10) **Patent Number: US RE38,854 E**
(45) **Date of Reissued Patent: *Oct. 25, 2005**

(54) **APPARATUS FOR AND METHOD FOR POLISHING WORKPIECE**

(75) Inventors: **Masamichi Nakashiba**, Mitaka (JP); **Norio Kimura**, Fujisawa (JP); **Isamu Watanabe**, Tokyo (JP); **Kaori Yoshida**, Tokyo (JP)

(73) Assignee: **Ebara Corporation**, Tokyo (JP)

(*) Notice: This patent is subject to a terminal disclaimer.

(21) Appl. No.: **10/142,980**

(22) Filed: **May 13, 2002**

Related U.S. Patent Documents

Reissue of:

(64) Patent No.: **5,762,539**
Issued: **Jun. 9, 1998**
Appl. No.: **08/807,463**
Filed: **Feb. 27, 1997**

U.S. Applications:

(63) Continuation of application No. 09/589,388, filed on Jun. 8, 2000.

(30) **Foreign Application Priority Data**

Feb. 27, 1996 (JP) 8-65315

(51) **Int. Cl.⁷** **B24B 5/00**

(52) **U.S. Cl.** **451/41**; 451/5; 451/285; 451/286; 451/288

(58) **Field of Search** 451/41, 285-289, 451/388, 53, 5

(56) **References Cited**

U.S. PATENT DOCUMENTS

4,373,991 A 2/1983 Banks
5,486,129 A 1/1996 Sandhu et al.

5,584,751 A 12/1996 Kobayashi et al.
5,605,488 A 2/1997 Ohashi et al.
5,643,053 A 7/1997 Shendon
5,651,724 A * 7/1997 Kimura et al. 451/41
5,670,011 A 9/1997 Togawa et al.
5,795,215 A 8/1998 Guthrie et al.
5,908,530 A 6/1999 Hoshizaki et al.
5,941,758 A 8/1999 Mack
6,024,630 A 2/2000 Shendon et al.

FOREIGN PATENT DOCUMENTS

JP 401109066 4/1989
JP 401216768 8/1989
JP 404217456 8/1992
JP 6-333891 12/1994

OTHER PUBLICATIONS

U.S. Appl. No. 08/524,824, filed Sep. 7, 1995, Kimura et al., entitled "Method and Apparatus for Polishing Workpiece", now U.S. Pat. No. 5,651,724.

* cited by examiner

Primary Examiner—George Nguyen
(74) *Attorney, Agent, or Firm*—Wenderoth, Lind & Ponack, L.L.P.

(57) **ABSTRACT**

A polishing apparatus for polishing a workpiece such as a semiconductor wafer has a turntable with a polishing surface, and a top ring for holding a workpiece and pressing the workpiece against the polishing surface under a first pressing. The polishing apparatus has a pressurized fluid source for supplying pressurized fluid, and a plurality of openings provided in the holding surface of the top ring for ejecting the pressurized fluid supplied from the pressurized fluid source. A plurality of areas each having the openings are defined on the holding surface so that the pressurized fluid is selectively ejectable from the openings in the respective areas.

48 Claims, 9 Drawing Sheets

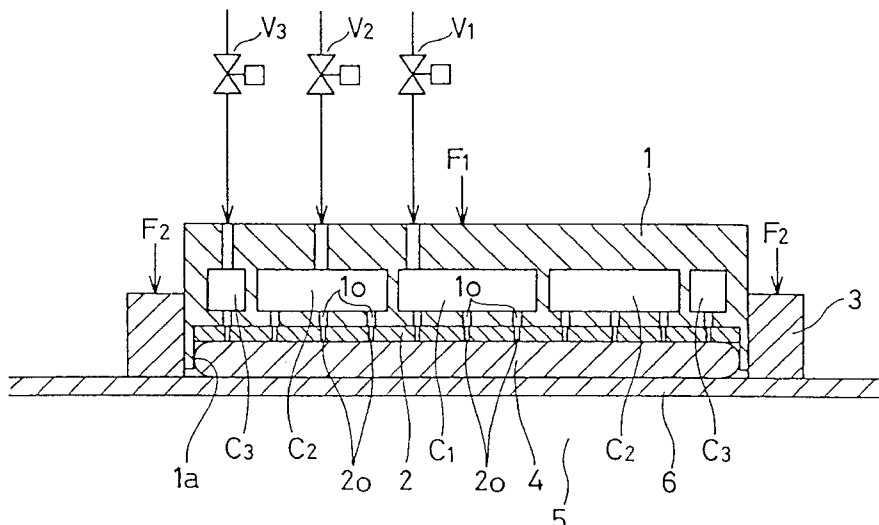

FIG. 1

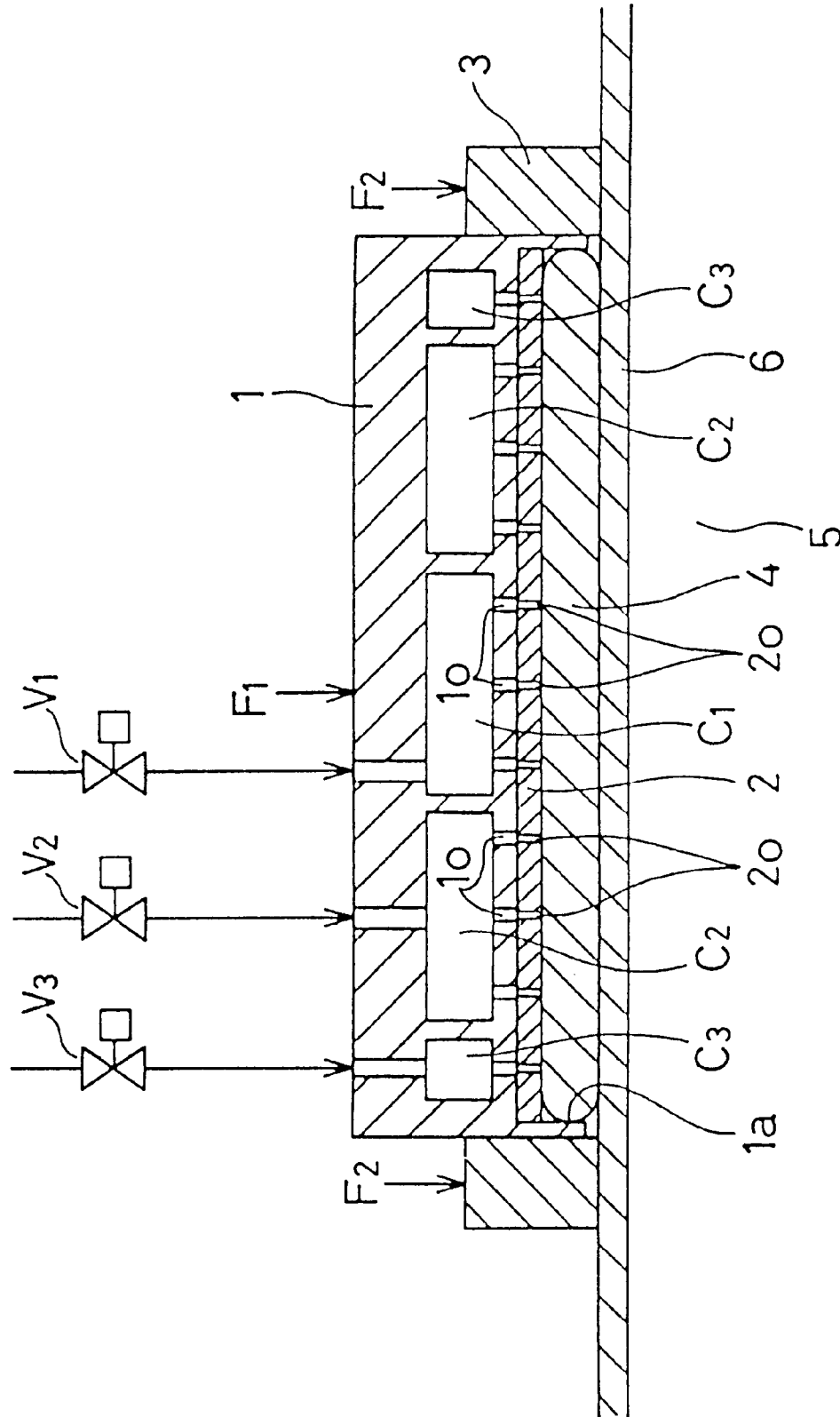

FIG. 2A

$F_1 > F_2$

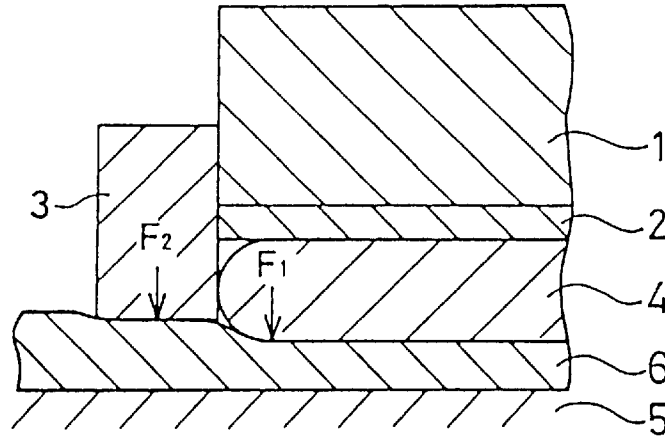

FIG. 2B

$F_1 \approx F_2$

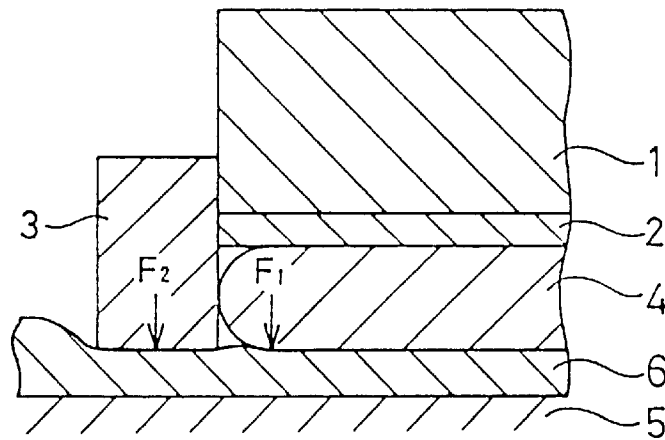

FIG. 2C

$F_1 < F_2$

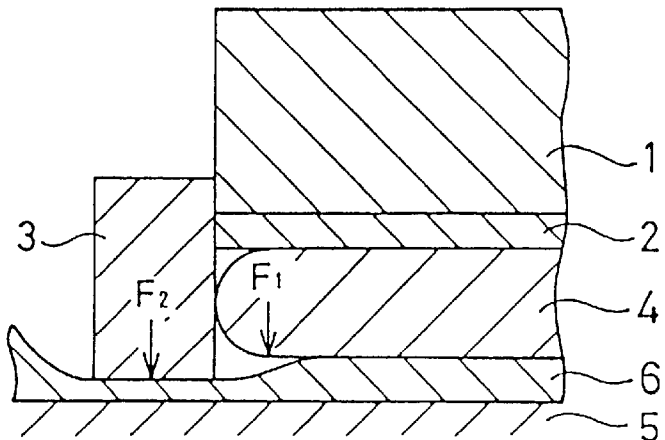

FIG. 3A

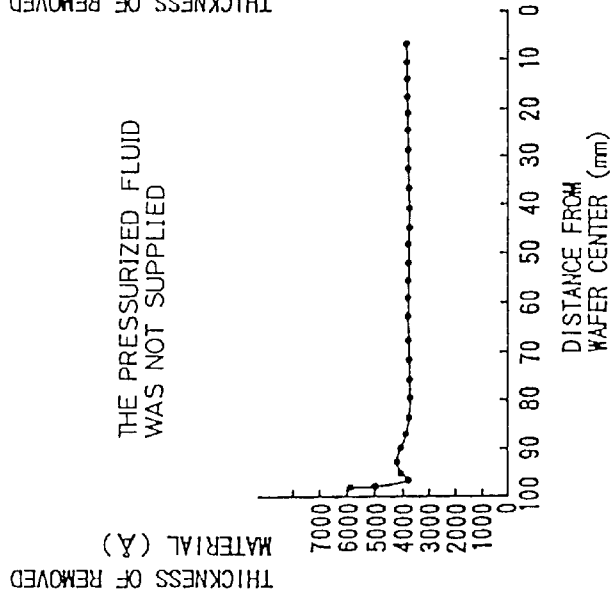

FIG. 3B

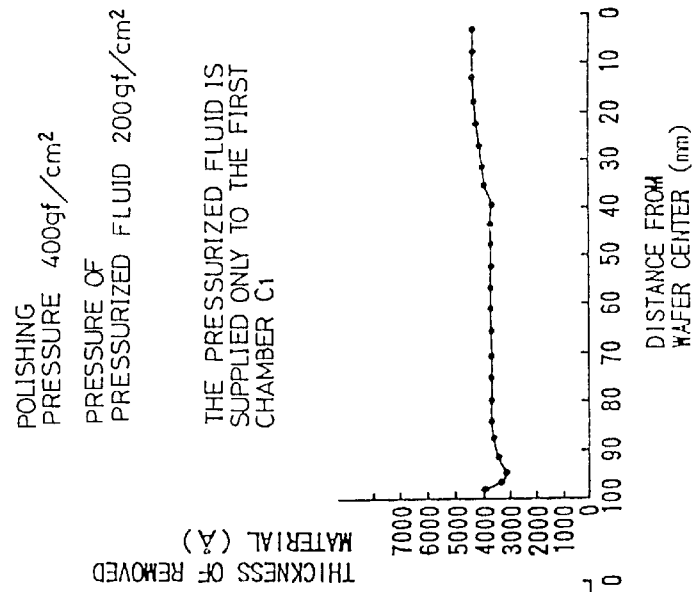
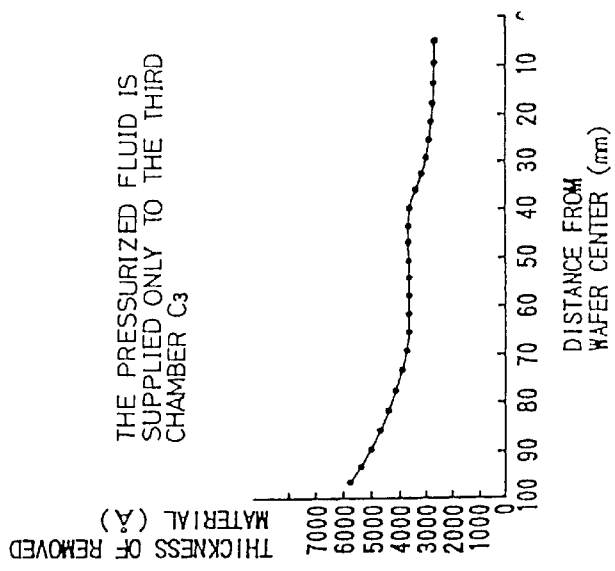

FIG. 3C



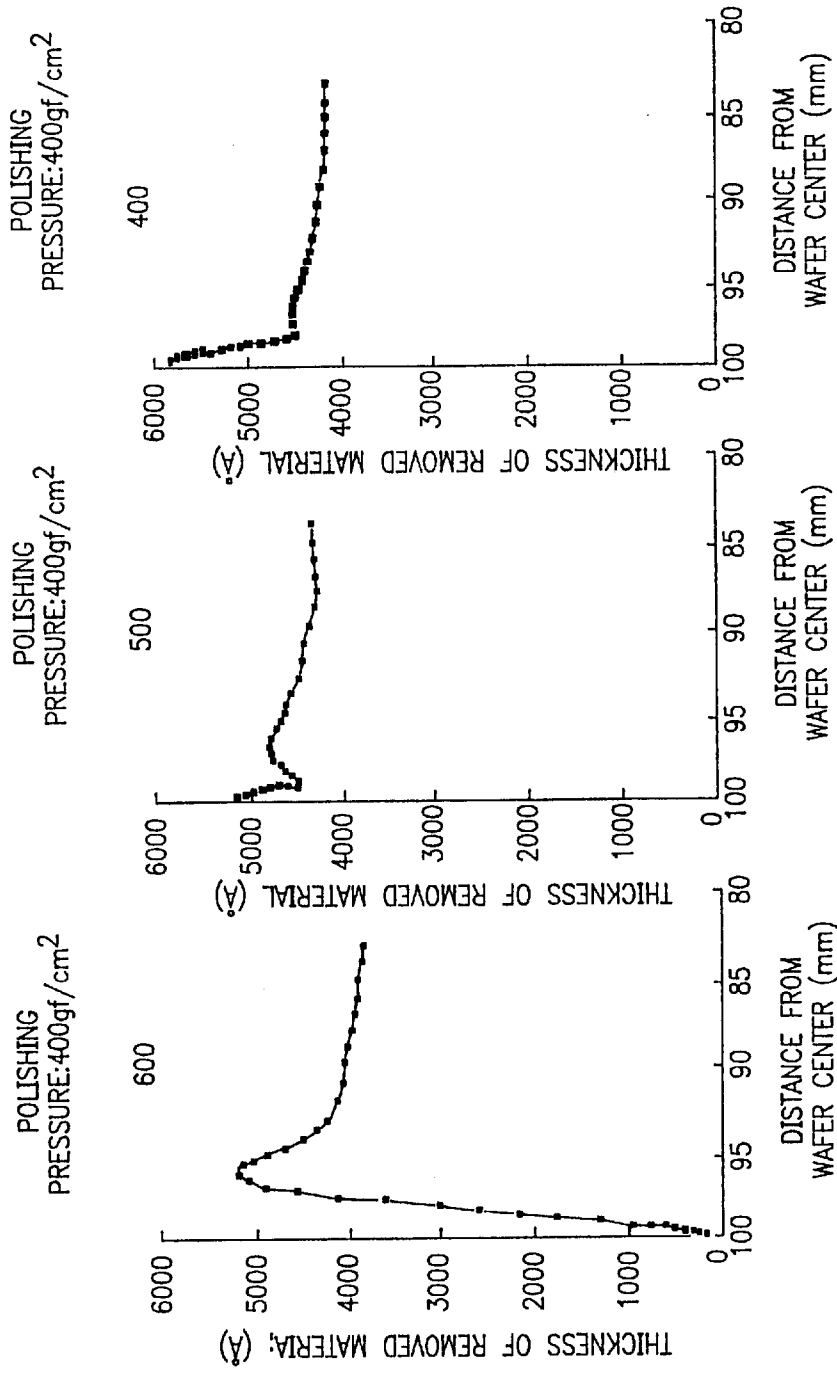

FIG. 4A

FIG. 4B

FIG. 4C

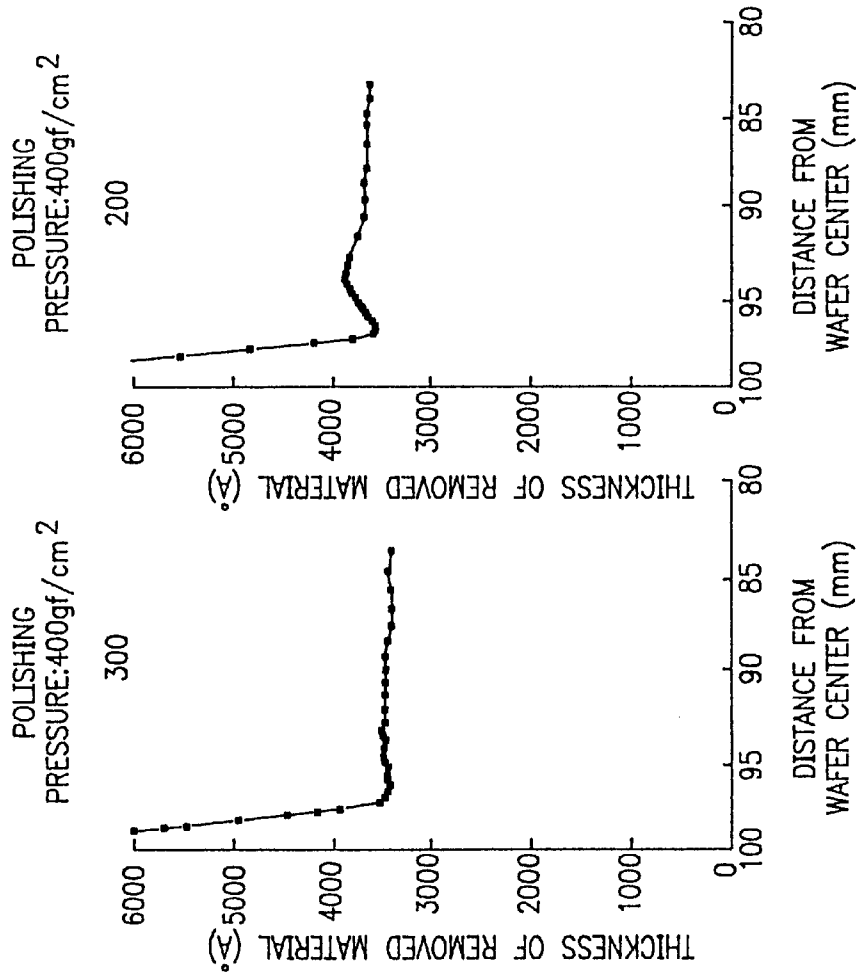

FIG. 4D

FIG. 4E

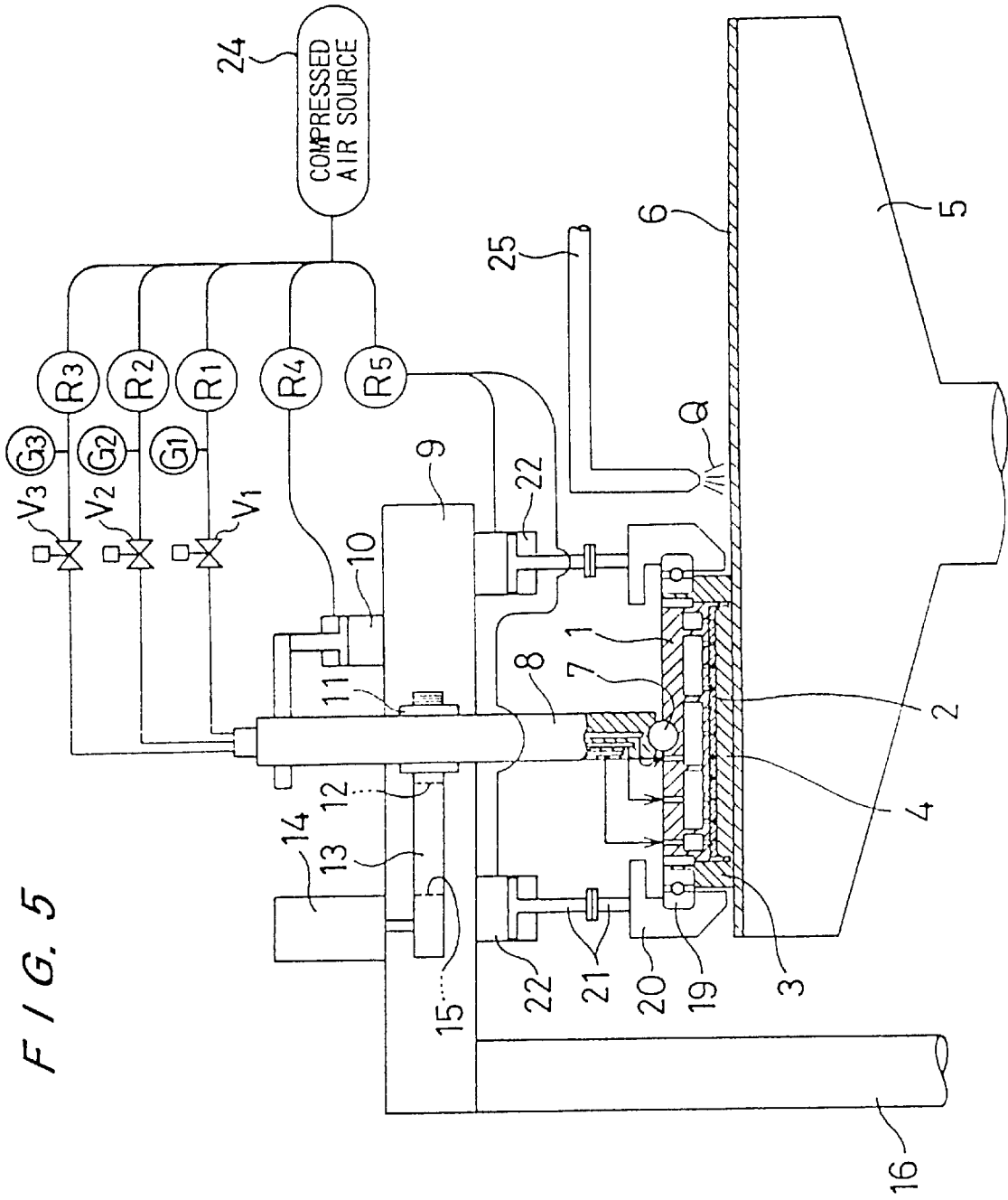

FIG. 5

FIG. 6

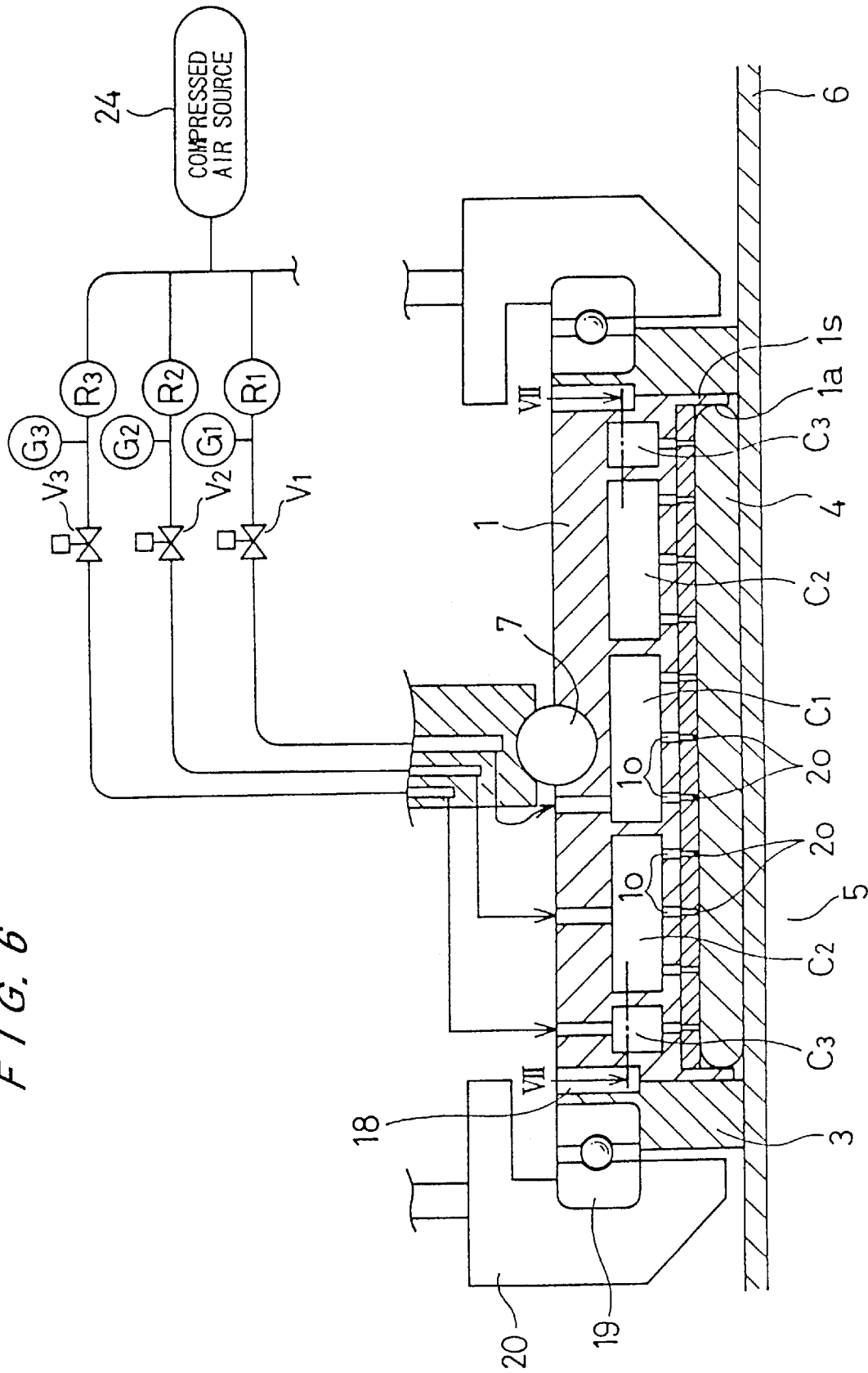

FIG. 7

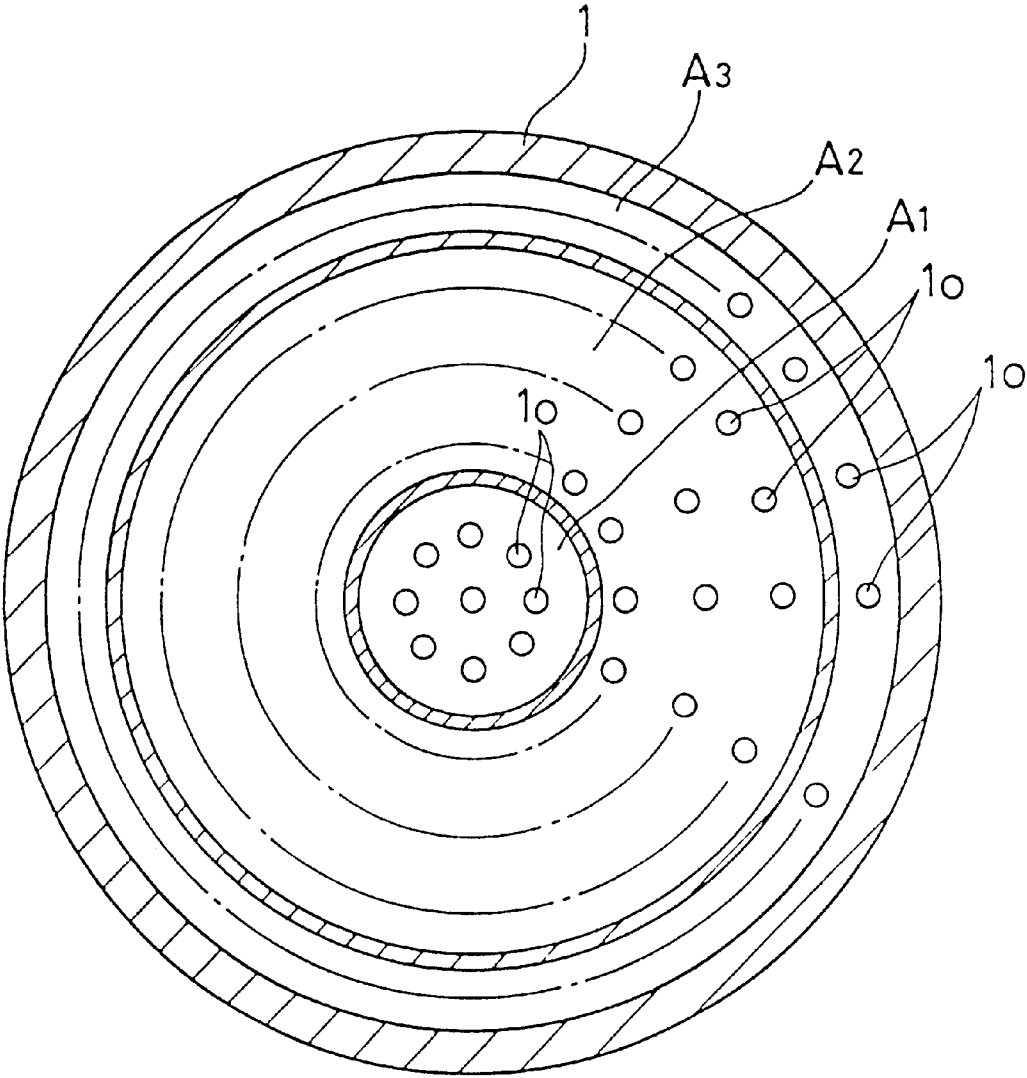
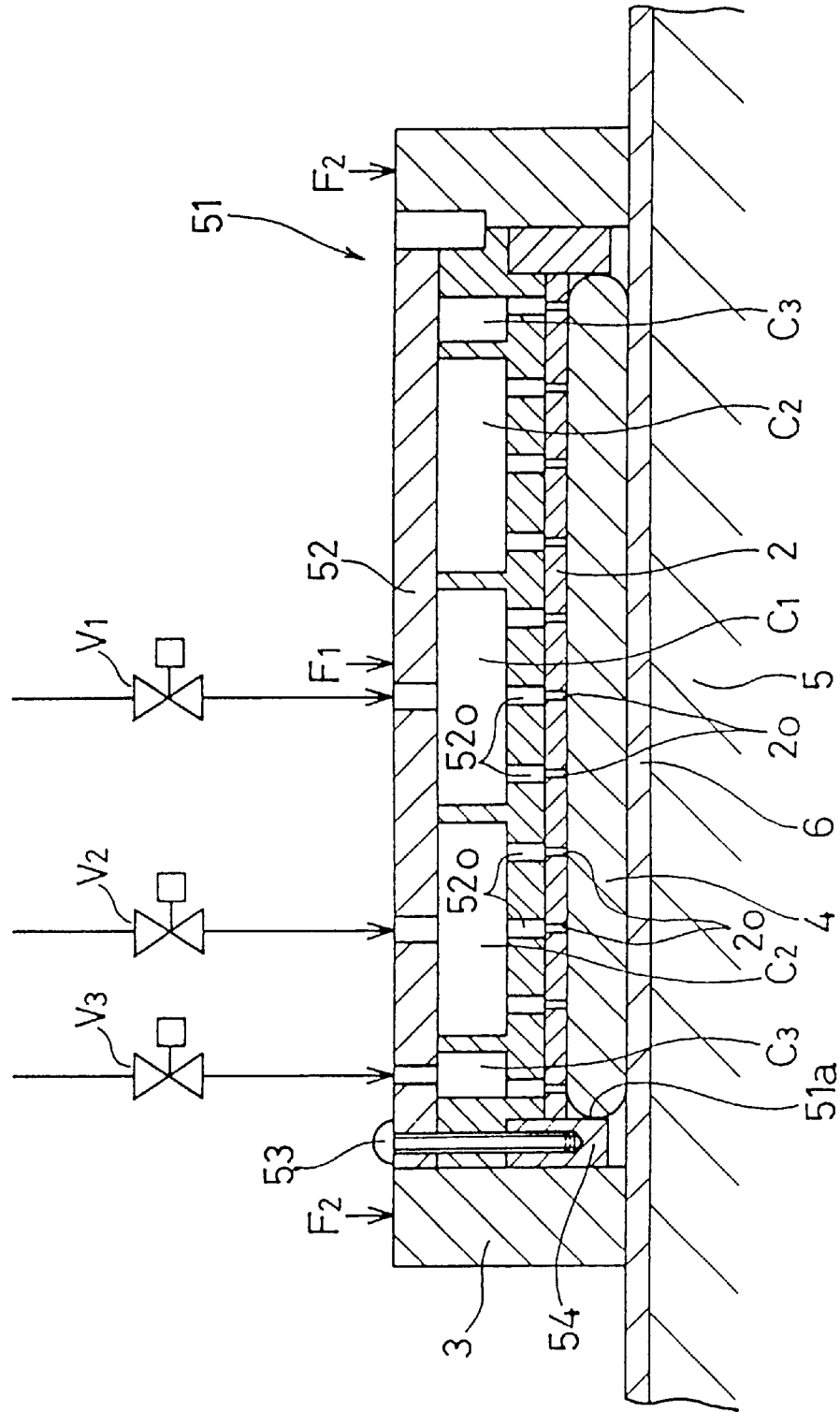

FIG. 8



APPARATUS FOR AND METHOD FOR POLISHING WORKPIECE

Matter enclosed in heavy brackets [] appears in the original patent but forms no part of this reissue specification; matter printed in italics indicates the additions made by reissue.

REFERENCE TO RELATED APPLICATIONS

This is a reissue of U.S. Pat. No. 5,762,539, and a continuation of reissue application No. 09/589,388, filed Jun. 8, 2000 which is a reissue application of U.S. Pat. No. 5,762,539. Reissue application No. 10/976,330, filed Oct. 29, 2004, is a divisional application of this reissue application (reissue application No. 10/142,980).

BACKGROUND OF THE INVENTION

1. Field of the Invention

The present invention relates to an apparatus for and a method of polishing a workpiece such as a semiconductor wafer to a flat mirror finish, and more particularly to an apparatus for and a method of polishing a workpiece such as a semiconductor wafer which can control the amount of a material removed from a desired area of the workpiece by a polishing action.

2. Description of the Related Art

Recent rapid progress in semiconductor device integration demands smaller and smaller wiring patterns or interconnections and also narrower spaces between interconnections which connect active areas. One of the processes available for forming such interconnection is photolithography. Though the photolithographic process can form interconnections that are at most 0.5 μm wide, it requires that surfaces on which pattern images are to be focused by a stepper be as flat as possible because the depth of focus of the optical system is relatively small.

It is therefore necessary to make the surfaces of semiconductor wafers flat for photolithography. One customary way of flattening the surfaces of semiconductor wafers is to polish them with a polishing apparatus.

Conventionally, a polishing apparatus has a turntable and a top ring which rotate at respective individual speeds. A polishing cloth is attached to the upper surface of the turntable. A semiconductor wafer to be polished is placed on the polishing cloth and clamped between the top ring and the turntable. An abrasive liquid containing abrasive grains is supplied onto the polishing cloth and retained on the polishing cloth. During operation, the top ring exerts a certain pressure on the turntable, and the surface of the semiconductor wafer held against the polishing cloth is therefore polished to a flat mirror finish while the top ring and the turntable are rotating.

The polishing apparatus is required to have such performance that the surfaces of semiconductor wafers have a highly accurate flatness. Therefore, it is preferable that the lower end surface (the holding surface) of the top ring which holds a semiconductor wafer and the contact surface of the polishing cloth which is held in contact with the semiconductor wafer, and hence the surface of the turntable to which the polishing cloth is attached, have a highly accurate flatness, and those surfaces which are highly accurately flat have been used in the art. The lower surface of the top ring and the upper surface of the polishing cloth are parallel to each other as in the ordinal cases.

It is known that the polishing action of the polishing apparatus is affected not only by the configurations of the

holding surface of the top ring and the contact surface of the polishing cloth, but also by the relative speed between the polishing cloth and the semiconductor wafer, the distribution of pressure applied to the surface of the semiconductor wafer which is being polished, the amount of the abrasive liquid on the polishing cloth, and the period of time when the polishing cloth has been used. It is considered that the surface of the semiconductor wafer can be highly accurately flat if the above factors which affect the polishing action of the polishing apparatus are equalized over the entire surface of the semiconductor wafer to be polished. The larger the size of the semiconductor wafer is, the more difficult the above factors are equalized.

However, some of the above factors can easily be equalized over the entire surface of the semiconductor wafer, but the other factors cannot be equalized. For example, the relative speed between the polishing cloth and the semiconductor wafer can easily be equalized by rotating the turntable and the top ring at the same rotational speed and in the same direction. However, it is difficult to equalize the amount of the abrasive liquid on the polishing cloth because of a centrifugal forces imposed on the abrasive liquid.

The above approach which tries to equalize all the factors affecting the polishing action, including the flatnesses of the lower end surface of the top ring and the upper surface of the polishing cloth on the turntable, over the entire surface of the semiconductor wafer to be polished poses limitations on efforts to make the polished surface of the semiconductor wafer flat, often resulting in a failure to accomplish a desired degree of flatness of the polished surface.

It has been customary to achieve a more accurate flatness by making the holding surface of the top ring concave or convex to develop a certain distribution of pressure on the surface of the semiconductor wafer for thereby correcting irregularities of the polishing action which are caused by an irregular entry of the abrasive liquid and variations in the period of time when the polishing cloth has been used.

However, various problems have arisen in the case where a specific configuration is applied to the holding surface of the top ring. Specifically, since the holding surface of the top ring is held in contact with the semiconductor wafer at all times, the holding surface of the top ring affects the polishing action continuously all the time while the semiconductor wafer is being polished. Because the configuration of the holding surface of the top ring has direct effect on the polishing action, it is highly complex to correct irregularities of the polishing action by intentionally making the holding surface of the top ring concave or convex, i.e., non-flat. If the holding surface of the top ring which has been made intentionally concave or convex is inadequate, the polished surface of the semiconductor wafer may not be made as flat as desired, or irregularities of the polishing action may not be sufficiently corrected, so that the polished surface of the semiconductor wafer may not be sufficiently flat.

In addition, inasmuch as the holding surface of the top ring is of substantially the same size as the surface of the semiconductor wafer to be polished, the holding surface of the top ring is required to be made irregular in a very small area. Because such surface processing is highly complex, it is not easy to correct irregularities of the polishing action by means of the configuration of the holding surface of the top ring.

The conventional polishing apparatuses, particularly those for polishing semiconductor wafers, are required to polish workpiece surfaces to higher flatness. There have not been available suitable means and apparatus for polishing

workpieces to shapes which are intentionally not flat or for polishing workpieces such that desired localized areas of workpiece surfaces are polished to different degrees.

SUMMARY OF THE INVENTION

It is therefore an object of the present invention to provide a polishing apparatus which can easily correct irregularities of a polishing action on a workpieces such as a semiconductor wafer, and polish a workpiece with an intensive polishing action on a desired localized area thereof.

According to an aspect of the present invention, there is provided a polishing apparatus for polishing a surface of a workpiece comprising: a turntable having a polishing surface thereon; a top ring for supporting the workpiece to be polished and pressing the workpiece against the polishing surface under a first pressing force, the top ring having a holding surface for holding the workpiece; a pressurized fluid source for supplying pressurized fluid; a plurality of openings provided in the holding surface of the top ring for ejecting the pressurized fluid supplied from the pressurized fluid source, a plurality of areas each having the openings being defined in the holding surface so that the pressurized fluid is selectively ejectable from the openings in the respective areas.

According to another aspect of the present invention, there is provided a method of polishing a workpiece, comprising the steps of: holding a workpiece between a polishing surface of a turntable and a holding surface of a top ring disposed above the turntable; pressing the workpiece by the top ring against the polishing surface under a first pressing force; and ejecting pressurized fluid from openings in a plurality of areas in the holding surface of the top ring toward the workpiece held by the top ring, the pressurized fluid being selectively ejectable from the openings in the respective areas; and polishing the workpiece in such a state that a pressing force applied to the workpiece by the pressurized fluid is variable in a central portion and an outer circumferential portion of the workpiece, respectively.

The above and other objects, features, and advantages of the present invention will become apparent from the following description when taken in conjunction with the accompanying drawings which illustrate preferred embodiments of the present invention by way of example.

BRIEF DESCRIPTION OF THE DRAWINGS

FIG. 1 is a fragmentary vertical cross-sectional view showing the basic principles of the present invention;

FIGS. 2A, 2B, and 2C are enlarged fragmentary vertical cross-sectional views showing the behavior of an polishing cloth when the relationship between a pressing force applied by a top ring and a pressing force applied by a presser ring is varied;

FIGS. 3A through 3C are graphs showing the results of an experiment in which a semiconductor wafer was polished based on the basic principles of the present invention;

FIGS. 4A through 4E are graphs showing the results of an experiment in which a semiconductor wafer was polished based on the basic principles of the present invention;

FIG. 5 is a vertical cross-sectional view of a polishing apparatus according to a first embodiment of the present invention;

FIG. 6 is an enlarged vertical cross-sectional view showing details of a top ring and a presser ring of the polishing apparatus according to the first embodiment;

FIG. 7 is a cross-sectional view taken along line VII—VII of FIG. 6; and

FIG. 8 is an enlarged vertical cross-sectional view of a polishing apparatus according to a second embodiment of the present invention.

DETAILED DESCRIPTION OF THE PREFERRED EMBODIMENTS

Like or corresponding parts are denoted by like or corresponding reference numerals throughout views.

FIG. 1 shows the basic principles of the present invention. As shown in FIG. 1, a top ring 1 has therein a circular first chamber C_1 at a central position thereof, an annular second chamber C_2 disposed at a radially outer side of the first chamber C_1 , and an annular third chamber C_3 disposed at a radially outer side of the second chamber C_2 . The first chamber C_1 is connected to a pressurized fluid source through a valve V_1 , the second chamber C_2 is connected to a pressurized fluid source through a valve V_2 , and the third chamber C_3 is connected to a pressurized fluid source through a valve V_3 . The top ring 1 has a recess 1a defined in a lower surface thereof for accommodating therein a semiconductor wafer 4 which is a workpiece to be polished. An elastic pad 2 of polyurethane or the like is attached to the lower surface of the top ring 1.

The top ring 1 and the elastic pad 2 have a plurality of openings 1o and 2o, respectively, which are in registry with each other. Each of the openings 1o and 2o is communicated with anyone of the first chamber C_1 , the second chamber C_2 , and the third chamber C_3 . That is, a plurality of openings each comprising the openings 1o and 2o for ejecting pressurized fluid are provided in a holding surface of the top ring 1 for holding the semiconductor wafer 4 to be polished. Thus, three concentric annular areas are defined on the holding surface of the top ring 1 by allowing the openings 1o and 2o to be communicated with anyone of the first, second and third chambers C_1 , C_2 and C_3 . The pressurized fluid is ejectable from the openings in the respective annular areas, separately.

A presser ring 3 is disposed around the top ring 1 and is vertically movable with respect to the top ring 1. A turntable 5 having an upper surface to which a polishing cloth 6 is attached is provided below the top ring 1. The top ring 1 applies a pressing force F_1 (pressure per unit area, gf/cm^2) to press the semiconductor wafer 4 against the polishing cloth 6 on the turntable 5, and the presser ring 3 applies a pressing force F_2 (pressure per unit area, gf/cm^2) to press the polishing cloth 6. These pressing forces F_1 , F_2 are variable independently of each other.

During polishing, pressurized fluid such as compressed air is supplied to the first, second and third chambers C_1 , C_2 and C_3 , selectively, and the supplied pressurized fluid is ejected from the lower surface of the elastic pad 2 through the openings 1o and 2o and is supplied between the holding surface of the top ring 1 and the upper surface of the semiconductor wafer 4. At this time, at least one of the first, second and third chambers C_1 , C_2 and C_3 to which pressurized fluid is supplied is selected, and hence at least one of the annular areas, from which pressurized fluid is ejected, in the holding surface of the top ring 1 is selected. For example, pressurized fluid is supplied only to the first chamber C_1 , and is not supplied to the second and third chambers C_2 and C_3 , and thus the pressurized fluid is ejected only from the central area of the holding surface of the top ring 1. As a result, the semiconductor wafer 4 is pressed against the polishing cloth 6 by the pressurized fluid in such a state that the polishing pressure applied to the central portion of the semiconductor wafer 4 is larger than the polishing pressure applied to outer

5

circumferential portion of the semiconductor wafer 4. Thus, if the amount of a material removed from the outer circumferential portion of the semiconductor wafer 4 is larger than the amount of a material removed from the central portion of the semiconductor wafer 4, insufficient polishing action at the central portion of the semiconductor wafer can be corrected by utilizing the pressing action of the pressurized fluid.

On the other hand, if the amount of a material removed from the central portion of the semiconductor wafer 4 is larger than the amount of a material removed from the outer circumferential portion of the semiconductor wafer 4, the pressurized fluid is supplied only to the third chamber C_3 , and is not supplied to the first and second chambers C_1 and C_2 , and thus the pressurized fluid is ejected only from the outer circumferential area of the holding surface of the top ring 1.

As a result, the polishing pressure applied to the outer circumferential portion of the semiconductor wafer 4 is made larger than the central portion of the semiconductor wafer 4. Thus, insufficient polishing action at the outer circumferential portion of the semiconductor wafer can be collected, and the entire surface of the semiconductor wafer 4 can be uniformly polished.

The pressures of pressurized fluid supplied to the first chamber C_1 , the second chamber C_2 and the third chamber C_3 are changed, respectively. That is, pressurized fluid having a pressure of P_1 gf/cm² is supplied to the first chamber C_1 , pressurized fluid having a pressure p_2 gf/cm² is supplied to the second chamber C_2 , and pressurized fluid having a pressure of p_3 gf/cm² is supplied to the third chamber C_3 , respectively. In this manner, the pressures of pressurized fluid ejected from the respective annular areas of the holding surface of the top ring 1 are varied, and the fluid which is supplied between the holding surface of the top ring 1 and the upper surface of the semiconductor wafer 4 has pressure gradient so as to be higher or lower progressively from the central area to the outer circumferential area of the semiconductor wafer 4, and hence the pressing force for pressing the semiconductor wafer 4 against the polishing cloth 6 has gradient so as to be higher or lower progressively from the central area to the outer circumferential area of the semiconductor wafer 4. Thus, irregularities of the polishing action can be sufficiently corrected and the localized area of the semiconductor wafer 4 is prevented from being polished excessively or insufficiently.

In the present invention, the pressing force F_1 (pressure per unit area, gf/cm²) for pressing the semiconductor wafer 4 against the polishing cloth 6, and the pressing force F_2 (pressure per unit area, gf/cm²) for pressing the polishing cloth 6 are variable independently of each other. Therefore, the pressing force F_2 which is applied to the polishing cloth 6 by the presser ring 3 can be changed depending on the pressing force F_1 which is applied by the top ring 1 to press the semiconductor wafer 4 against the polishing cloth 6.

Theoretically, if the pressing force F_1 which is applied by the top ring 1 to press the semiconductor wafer 4 against the polishing cloth 6 is equal to the pressing force F_2 which is applied to the polishing cloth 6 by the presser ring 3, then the distribution of applied polishing pressures, which result from a combination of the pressing forces F_1 , F_2 , is continuous and uniform from the center of the semiconductor wafer 4 to its peripheral edge and further to an outer circumferential edge of the presser ring 3 disposed around the semiconductor wafer 4. Accordingly, the peripheral portion of the semiconductor wafer 4 is prevented from being polished excessively or insufficiently.

6

FIGS. 2A through 2C schematically show how the polishing cloth 6 behaves when the relationship between the pressing force F_1 and the pressing force F_2 is varied. In FIG. 2A, the pressing force F_1 is larger than the pressing force F_2 ($F_1 > F_2$). In FIG. 2B, the pressing force F_1 is nearly equal to the pressing force F_2 ($F_1 = F_2$). In FIG. 2C, the pressing force F_1 is smaller than the pressing force F_2 ($F_1 < F_2$).

As shown in FIGS. 2A through 2C, when the pressing force F_2 applied to the polishing cloth 6 by the presser ring 3 is progressively increased, the polishing cloth 6 pressed by the presser ring 3 is progressively compressed, thus progressively changing its state of contact with the peripheral portion of the semiconductor wafer 4. i.e., progressively reducing its area of contact with the peripheral portion of the semiconductor wafer 4. Therefore, when the relationship between the pressing force F_1 and the pressing force F_2 is changed in various patterns, the distribution of polishing pressures on the semiconductor wafer 4 over its peripheral portion and inner region is also changed in various patterns.

As shown in FIG. 2A, when the pressing force F_1 is larger than the pressing force F_2 ($F_1 > F_2$), the polishing pressure applied to the peripheral portion of the semiconductor wafer 4 is larger than the polishing pressure applied to the inner region of the semiconductor wafer 4 so that the amount of a material removed from the peripheral portion of the semiconductor wafer 4 is larger than the amount of a material removed from the inner region of the semiconductor wafer 4 while the semiconductor wafer 4 is being polished.

As shown in FIG. 2B, when the pressing force F_1 is substantially equal to the pressing force F_2 ($F_1 = F_2$), the distribution of polishing pressures is continuous and uniform from the center of the semiconductor wafer 4 to its peripheral edge and further to the outer circumferential edge of the presser ring 3, so that the amount of a material removed from the semiconductor wafer 4 is uniform from the peripheral edge to the inner region of the semiconductor wafer 4 while the semiconductor wafer 4 is being polished.

As shown in FIG. 2C, when the pressing force F_1 is smaller than the pressing force F_2 ($F_1 < F_2$), the polishing pressure applied to the peripheral portion of the semiconductor wafer 4 is smaller than the polishing pressure applied to the inner region of the semiconductor wafer 4, so that the amount of a material removed from the peripheral edge of the semiconductor wafer 4 is smaller than the amount of a material removed from the inner region of the semiconductor wafer 4 while the semiconductor wafer 4 is being polished.

The pressing force F_1 and the pressing force F_2 can be changed independently of each other before polishing or during polishing.

As described above, according to the present invention, pressurized fluid is ejected from the holding surface of the top ring 1. At this time, the areas from which the pressurized fluid is ejected are suitably selected, and the pressing force applied to the semiconductor wafer 4 by the pressurized fluid is changed in the central portion and, the outer circumferential portion of the semiconductor wafer 4, respectively, during polishing.

In parallel with the above process, the pressing force F_2 of the presser ring 3 disposed around the top ring 1 is determined on the basis of the pressing force F_1 of the top ring 1, and the semiconductor wafer 4 is polished while pressing the polishing cloth 6 by the presser ring 3 under the pressing force F_2 which has been determined. Further, the pressing force F_2 is determined on the basis of the pressure

distribution which is applied to the semiconductor wafer 4 by the pressurized fluid, and the semiconductor wafer 4 is polished by a combination of an action caused by the pressurized fluid and an action caused by the presser ring 3. In this manner, insufficient polishing action in thus localized area (for example, the central area or the outer circumferential area) of the semiconductor wafer can be corrected, and the localized area of the semiconductor wafer is prevented from being polished excessively or insufficiently. In the case where the polishing pressure applied to the central portion of the semiconductor wafer 4 is made larger than the outer circumferential portion of the semiconductor wafer 4 by supplying the pressurized fluid, the pressing force F_2 of the presser ring 3 is made larger than the pressing force F_1 of the top ring 1. Conversely, in the case where the polishing pressure applied to the outer circumferential portion of the semiconductor wafer 4 is made larger than the central portion of the semiconductor wafer 4 by supplying the pressurized fluid, the pressing force F_2 of the presser ring 3 is made smaller than the pressing force F_1 of the top ring 1.

FIGS. 3A through 3C show the results of an experiment in which a semiconductor wafer was polished based on the basic principles of supply of pressurized fluid according to the present invention. The semiconductor wafer used in the experiment was an 8-inch semiconductor wafer. In the experiment, the pressing force (polishing pressure) applied to the semiconductor wafer by the top ring was a constant level of 400 gf/cm², and the supply of the pressurized fluid was controlled. FIG. 3A shows the case in which the pressurized fluid was not supplied. FIG. 3B shows the case in which the pressurized fluid is supplied only to the first chamber C_1 , and FIG. 3C shows the case in which the pressurized fluid is supplied only to the third chamber C_3 . The pressure of the pressurized fluid was 200 gf/cm². In each of FIGS. 3A through 3C, the horizontal axis represents a distance (mm) from the center of the semiconductor wafer, and the vertical axis represents a thickness (Å) of a material removed from a semiconductor wafer.

As shown in FIGS. 3A through 3C, the thickness of the removed material at the radial positions on the semiconductor wafer is affected by controlling the supply of the pressurized fluid. Specifically, when the pressurized fluid was not supplied, as shown in FIG. 3A, the peripheral portion of the semiconductor wafer was excessively polished. When the pressurized fluid is supplied only to the first chamber C_1 to press only the central portion of the semiconductor wafer by the pressurized fluid, as shown in FIG. 3B, the peripheral portion of the semiconductor wafer was not excessively polished and the central portion of the semiconductor wafer was slightly excessively polished. When the pressurized fluid was supplied only to the third chamber C_3 to press only the outer circumferential portion of the semiconductor wafer by the pressurized fluid, as shown in FIG. 3C, the outer circumferential portion of the semiconductor wafer was excessively polished and the central portion of the semiconductor wafer was polished insufficiently.

As described above, the experimental result shown in FIGS. 3A through 3E indicate that the amount of the material removed from the localized area of the semiconductor wafer can be adjusted by controlling supply of the pressurized fluid.

FIGS. 4A through 4E show the results of an experiment in which a semiconductor wafer was polished based on the basic principles of the present invention. The semiconductor wafer used in the experiment was an 8-inch semiconductor wafer. In the experiment, the pressing force (polishing pressure) applied to the semiconductor wafer by the top ring

was a constant level of 400 gf/cm², and the pressing force applied by the presser ring was changed from 600 to 200 gf/cm² successively by decrements of 100 gf/cm². Specifically, the pressing force applied by the presser ring was 600 gf/cm² in FIG. 4A, 500 gf/cm² in FIG. 4B, 400 gf/cm² in FIG. 4C, 300 gf/cm² in FIG. 4D, and 200 gf/cm² in FIG. 4E. In each of FIGS. 4A through 4E, the horizontal axis represents a distance (rom) from the center of the semiconductor wafer, and the vertical axis represents a thickness (Å) of a material removed from the semiconductor wafer.

As shown in FIGS. 4A through 4E, the thickness of the removed material at the radial positions on the semiconductor wafer is affected when the pressing force applied by the presser ring was changed. Specifically, when the pressing force applied by the presser ring was in the range from 200 to 300 gf/cm² as shown in FIGS. 4D and 4E, the peripheral portion of the semiconductor wafer was excessively polished. When the pressing force applied by the presser ring was in the range from 400 to 500 gf/cm², as shown in FIGS. 4B and 4C, the peripheral portion of the semiconductor wafer is substantially equally polished from the peripheral edge to the inner region of the semiconductor wafer. When the pressing force applied by the presser ring was 600 gf/cm² as shown in FIG. 4A, the peripheral portion of the semiconductor wafer was polished insufficiently.

The experimental results shown in FIGS. 4A through 4E indicate that the amount of the material removed from the peripheral portion of the semiconductor wafer can be adjusted by varying the pressing force applied by the presser ring independently of the pressing force applied by the top ring. From a theoretical standpoint, the peripheral portion of the semiconductor wafer should be polished optimally when the pressing force applied by the presser ring is equal to the pressing force applied by the top ring. However, since the polishing action depends on the type of the semiconductor wafer and the polishing conditions, the pressing force applied by the presser ring is selected to be of an optimum value based on the pressing force applied by the top ring depending on the type of the semiconductor wafer and the polishing conditions.

There are demands for the removal of a larger or smaller thickness of material from the peripheral portion of the semiconductor wafer than from the inner region of the semiconductor wafer depending on the type of the semiconductor wafer. To meet such demands, the pressing force applied by the presser ring is selected to be of an optimum value based on the pressing force applied by the top ring to intentionally increase or reduce the amount of the material removed from peripheral portion of the semiconductor wafer.

FIGS. 5 through 7 show a polishing apparatus according to a first embodiment of the present invention.

As shown in FIGS. 5 and 6, a top ring 1 has therein a circular first chamber C_1 at a central position thereof, an annular second chamber C_2 disposed at a radially outer side of the first chamber C_1 , and an annular third chamber C_3 disposed at a radially outer side of the first chamber C_2 . The first chamber C_1 is connected to a compressed air source 24 as a pressurized fluid source through a valve V_1 and a regulator R_1 , the second chamber C_2 is connected to the compressed air source 24 through a valve V_2 and a regulator R_2 , and the third chamber C_3 is connected to the compressed air source 24 through a valve V_3 and a regulator R_3 . The top ring 1 has a recess 1a defined in a lower surface thereof for accommodating therein a semiconductor wafer 4 which is a

workpiece to be polished. An elastic pad 2 of polyurethane or the like is attached to the lower surface of the top ring 1.

The top ring 1 and the elastic pad 2 have a plurality of openings 1o and 2o, respectively, which are in registry with each other. Each of the openings 1o and 2o is communicated with any one of the first chamber C₁, the second chamber C₂, and the third chamber C₃. That is, a plurality of openings each comprising the openings 1o and 2o for ejecting pressurized fluid are defined on a holding surface of the top ring 1 for holding the semiconductor wafer 4 to be polished. Thus, three concentric annular areas A₁, A₂ and A₃ are defined in the holding surface of the top ring 1 by allowing the openings 1o and 2o to be communicated with anyone of the first, second and third chambers C₁, C₂ and C₃. The compressed air having different pressure from one another can be supplied to respective annular areas A₁, A₂ and A₃. Pressure gages or pressure sensors G₁, G₂ and G₃ are provided in the respective pressurized fluid supply lines, and the pressure in the respective chambers C₁, C₂ and C₃ can be independently controlled on the basis of the pressures detected by the pressure gages G₁, G₂ and G₃.

A presser ring 3 is disposed around the top ring 1 and is vertically movable with respect to the top ring 1. A turntable 5 with a polishing cloth 6 attached to an upper surface thereof is disposed below the top ring 1.

The top ring 1 is connected to a vertical top ring shaft 8 whose lower end is held against a ball 7 mounted on an upper surface of the top ring 1. The top ring shaft 8 is operatively coupled to a top ring air cylinder 10 fixedly mounted on an upper surface of a top ring head 9. The top ring shaft 8 is vertically movable by the top ring air cylinder 10 to press the semiconductor wafer 4 supported on the elastic pad 2 against the polishing cloth 6 on the turntable 5.

The top ring shaft 8 has an intermediate portion extending through and corotatably coupled to a rotatable cylinder 11 by a key (not shown), and the rotatable cylinder 11 has a pulley 12 mounted on outer circumferential surface thereof. The pulley 12 is operatively connected by a timing belt 13 to a timing pulley 15 mounted on the rotatable shaft of a top ring motor 14 which is fixedly mounted on the top ring head 9. Therefore, when the top ring motor 14 is energized, the rotatable cylinder 11 and the top ring shaft 8 are integrally rotated through the timing pulley 15, the timing belt 13 and the timing pulley 12. Thus the top ring 1 is rotated. The top ring head 9 is supported by a top ring head shaft 16 which is vertically fixed on a frame (not shown).

The presser ring 3 is corotatably, but vertically movably, coupled to the top ring 1 by a key 18. The presser ring 3 is rotatably supported by a bearing 19 which is mounted on a bearing holder 20. The bearing holder 20 is connected by vertical shafts 21 to a plurality of (three in this embodiment) circumferentially spaced presser ring air cylinders 22. The presser ring air cylinders 22 are secured to a lower surface of the top ring head 9.

The top ring air cylinder 10 and the presser ring air cylinders 22 are pneumatically connected to the compressed air source 24 through regulators R₄ and R₅, respectively. The regulator R₄ regulates an air pressure supplied from the compressed air source 24 to the top ring air cylinder 10 to adjust the pressing force which is applied by the top ring 1 to press the semiconductor wafer 4 against the polishing cloth 6. The regulator R₅ also regulates the air pressure supplied from the compressed air source 24 to the presser ring air cylinder 22 to adjust the pressing force which is applied by the presser ring 3 to press the polishing cloth 6. The regulators R₄ and R₅ are controlled by a controller (not shown in FIG. 5).

An abrasive liquid supply nozzle 25 is positioned above the turntable 5 for supplying an abrasive liquid Q onto the polishing cloth 6 on the turntable 5.

As shown in FIG. 6, the top ring 1 has an outer circumferential annular flange extending downwardly toward the turntable 5. The lower surface of the top ring 1 and the annular flange jointly define a recess 1a for accommodating the semiconductor wafer 4 therein.

The polishing apparatus shown in FIGS. 5, 6 and 7 operates as follows: The semiconductor wafer 4 to be polished is placed in the recess 1a and held against the elastic pad 2, and the top ring air cylinder 10 is actuated to lower the top ring 1 toward the turntable 5 until the semiconductor wafer 4 is pressed against the polishing cloth 6 on the upper surface of the rotating turntable 5. The top ring 1 and the presser ring 3 are rotated by the top ring motor 14 through the top ring shaft 8. Since the abrasive liquid Q is supplied onto the polishing cloth 6 by the abrasive liquid supply nozzle 25, the abrasive liquid Q is retained on the polishing cloth 6. Therefore, the lower surface of the semiconductor wafer 4 is polished with the abrasive liquid Q which is present between the lower surface of the semiconductor wafer 4 and the polishing cloth 6.

During polishing, compressed air is supplied from the compressed air source 24 to the first, second and third chambers C₁, C₂ and C₃ selectively, and the supplied compressed air is ejected from the lower surface of the elastic pad 2 through the openings 1o and 2o, and is supplied between the holding surface of the top ring 1 and the upper surface of the semiconductor wafer 4. At this time, at least one of the chambers C₁, C₂ and C₃ to which compressed air is supplied is selected, and at least one of the annular areas A₁, A₂ and A₃ from which compressed air is ejected is selected. For example, compressed air is supplied only to the first chamber C₁, and is not supplied to the second and third chambers C₂ and C₃, whereby the semiconductor wafer 4 is pressed against the polishing cloth 6 by the compressed air in such a state that the polishing pressure applied to the central portion of the semiconductor wafer 4 is larger than the polishing pressure applied to outer circumferential portion of the semiconductor wafer 4. Thus, if the amount of a material removed from the outer circumferential portion of the semiconductor wafer 4 is larger than the amount of a material removed from the central portion of the semiconductor wafer 4, insufficient polishing action at the central portion of the semiconductor wafer can be corrected by utilizing the pressing action of the pressurized fluid.

On the other hand, if the amount of a material removed from the central portion of the semiconductor wafer 4 is larger than the amount of a material removed from the outer circumferential portion of the semiconductor wafer 4, the compressed air is supplied only to the third chamber C₃, and is not supplied to the first and second chambers C₁ and C₂, whereby the polishing pressure applied to the outer circumferential portion of the semiconductor wafer 4 is larger than the polishing pressure applied to the central portion of the semiconductor wafer 4. Thus, insufficient polishing action at the outer circumferential portion of the semiconductor wafer can be corrected, and the entire surface of the semiconductor wafer 4 can be uniformly polished.

The pressures of compressed air supplied to the first chamber C₁, the second chamber C₂ and the third chamber C₃ are changed respectively, that is, compressed air having a pressure of p₁ gf/cm² is supplied to the first chamber C₁, compressed air having a pressure of p₂ gf/cm² is supplied to the second chamber C₂, and compressed air having a pres-

sure of p_3 gf/cm² is supplied. In this manner, the compressed air which is supplied between the holding surface of the top ring 1 and the upper surface of the semiconductor wafer 4 has pressure gradient so as to be higher or lower progressively from the central area to the outer circumferential area of the semiconductor wafer 4. That is, the pressing force for pressing the semiconductor wafer 4 against the polishing cloth 6 has gradient from the central area to the outer circumferential area of the semiconductor wafer 4. Thus, irregularities of the polishing action can be sufficiently corrected and the localized area of the semiconductor wafer 4 is prevented from being polished excessively or insufficiently.

Further, in the present invention, depending on the pressing force applied by the top ring 1 actuated by the top ring air cylinder 10, the pressing force applied to the polishing cloth 6 by the presser ring 3 actuated by the presser ring air cylinders 22 is adjusted while the semiconductor wafer 4 is being polished. During the polishing process, the pressing force F_1 (see FIG. 1) which is applied by the top ring 1 to press the semiconductor wafer 4 against the polishing cloth 6 can be adjusted by the regulator R_1 and the pressing force F_2 which is applied by the presser ring 3 to press the polishing cloth 6 can be adjusted by the regulator R_2 . Therefore, during the polishing process, the pressing force F_2 applied by the presser ring 3 to press the polishing cloth 6 can be changed depending on the pressing force F_1 applied by the top ring 1 to press the semiconductor wafer 4 against the polishing cloth 6. By adjusting the pressing force F_2 with respect to the pressing force F_1 , the distribution of polishing pressures is made continuous and uniform from the center of the semiconductor wafer 4 to its peripheral edge and further to the outer circumferential edge of the presser ring 3 disposed around the semiconductor wafer 4. Consequently, the peripheral portion of the semiconductor wafer 4 is prevented from being polished excessively or insufficiently. The semiconductor wafer 4 can thus be polished to a high quality and with a high yield.

If a larger or smaller thickness of material is to be removed from the peripheral portion of the semiconductor wafer 4 than from the inner region of the semiconductor wafer 4, then the pressing force F_2 applied by the presser ring 3 is selected to be of a suitable value based on the pressing force F_1 applied by the top ring 1 to intentionally increase or reduce the amount of a material removed from the peripheral portion of the semiconductor wafer 4.

By controlling compressed air supplied to the first, second and third chambers C_1 , C_2 and C_3 , the semiconductor wafer 4 is polished by a combination of a pressing action caused by the compressed air and a pressing action caused by the presser ring 3. Thus, insufficient polishing action in the localized area (for example, the central area or the outer circumferential area) of the semiconductor wafer can be corrected. Further, the amount of the material removed from the localized areas (for example, the central area or the outer circumferential area) can be intentionally increased or decreased. In this case, in the case where the polishing pressure at the central portion of the semiconductor wafer 4 is made larger than the polishing pressure at the outer circumferential portion of the semiconductor wafer 4, the pressing force F_2 of the presser ring 3 is made larger than the pressing force F_1 of the top ring 1. Conversely, in the case where the polishing pressure at the outer circumferential portion of the semiconductor wafer 4 is made larger than the polishing pressure at the central portion of the semiconductor wafer 4, the pressing force F_2 of the presser ring 3 is made smaller than the pressing force F_1 of the top ring 1.

In this embodiment, since the semiconductor wafer 4 is accommodated in the recess 1a of the top ring 1 and protected by the annular flange 1s, the outer circumferential surface of the semiconductor wafer 4 at its peripheral edge is not rubbed by the presser ring 3 when the presser ring 3 is vertically moved with respect to the top ring 1. Therefore, the presser ring 3 as it is vertically moved with respect to the top ring 1 does not adversely affect the polishing performance of the polishing apparatus during the polishing process.

FIG. 8 shows a polishing apparatus according to a second embodiment of the present invention. As shown in FIG. 8, a top ring 51 comprises a main body 52 and a ring member 54 detachably fixed by bolts 53 to a lower outer circumferential surface of the main body 52. The top ring 51 has a recess 51a for accommodating the semiconductor wafer 4. The recess 51a is defined by a lower surface of the main body 52 and an inner circumferential surface of the ring member 54. The semiconductor wafer 4 accommodated in the recess 51a has an upper surface held by the lower surface of the main body 52 and an outer circumferential surface held by the inner circumferential surface of the ring member 54. The presser ring 3 is vertically movably disposed around the top ring 51.

The main body 52 of the top ring 51 has therein a circular first chamber C_1 at a central position thereof, an annular second chamber C_2 disposed at a radially outer side of the first chamber C_1 , and an annular third chamber C_3 disposed at a radially outer side of the second chamber C_2 . The first chamber C_1 , the second chamber C_2 and the third chamber C_3 are connected to the compressed air source (not shown) to allow compressed air to be supplied thereto in the same manner as the embodiment in FIGS. 5 through 7. The main body 52 of the top ring 51 has a plurality of openings 52o which are communicated with the first chamber C_1 , the second chamber C_2 and the third chamber C_3 , respectively. An elastic pad 2 also has a plurality of openings 2o which are in registry with the openings 52o. Thus compressed air can be applied to the upper surface of the semiconductor wafer 4.

While the workpiece to be polished according to the present invention has been illustrated as a semiconductor wafer, it may be a glass product, a liquid crystal panel, a ceramic product, etc. Further, as pressurized fluid, pressurized liquid may be used. The top ring and the presser ring may be pressed by hydraulic cylinders rather than the illustrated air cylinders. The presser ring may be pressed by electric devices such as piezoelectric or electromagnetic devices rather than the illustrated purely mechanical devices.

As described above, the present invention offers the following advantages:

The distribution of the pressing force of the workpiece is prevented from being nonuniform at the peripheral portion of the workpiece during the polishing process, and the polishing pressures can be uniformized over the entire surface of the workpiece. Therefore, the peripheral portion of the semiconductor wafer is prevented from being polished excessively or insufficiently. The entire surface of workpiece can thus be polished to a flat mirror finish. In the case where the present invention is applied to semiconductor manufacturing processes, the semiconductor devices can be polished to a high quality. Since the peripheral portion of the semiconductor wafer can be used as products, yields of the semiconductor devices can be increased.

In the case where there are demands for the removal of a larger or smaller thickness of material from the peripheral

portion of the semiconductor wafer than from the inner region of the semiconductor wafer depending on the type of the semiconductor wafer, the amount of the material removed from the peripheral portion of the semiconductor wafer can be intentionally increased or decreased. Further, the amount of the material removed from not only the peripheral portion of the semiconductor wafer but also the localized area (for example, central portion or outer circumferential portion) can be intentionally increased or decreased.

Although certain preferred embodiments of the present invention have been shown and described in detail, it should be understood that various changes and modifications may be made therein without departing from the scope of the appended claims.

What is claimed is:

[1. A polishing apparatus for polishing a surface of a workpiece comprising:

a turntable having a polishing surface thereon;

a top ring for supporting the workpiece to be polished and pressing the workpiece against said polishing surface under a first pressing force, said top ring having a holding surface for holding the workpiece;

a pressurized fluid source for supplying pressurized fluid; a plurality of openings provided in said holding surface of said top ring for ejecting said pressurized fluid supplied from said pressurized fluid source, a plurality of areas each having said openings being defined in said holding surface so that said pressurized fluid is selectively ejectable from said openings in said respective areas.]

[2. An apparatus according to claim 1, wherein said plurality of areas comprises concentric annular areas.]

[3. An apparatus according to claim 1, wherein said plurality of areas are defined by communicating with a plurality of chambers, respectively formed in said top ring through said openings.]

[4. An apparatus according to claim 1, wherein said first pressing force and a pressure of said pressurized fluid are variable independently of each other.]

[5. An apparatus according to claim 1, wherein a pressure of said pressurized fluid is variable in each of said areas.]

[6. An apparatus according to claim 1, further comprising: a presser ring vertically movably disposed around said top ring; and

a pressing device for pressing said presser ring against said polishing surface under a second pressing force which is variable.]

[7. An apparatus according to claim 1, wherein said top ring has a recess defined therein for accommodating the workpiece therein.]

[8. A method of polishing a workpiece, comprising the steps of:

holding a workpiece between a polishing surface of a turntable and a holding surface of a top ring disposed above said turntable;

pressing the workpiece by said top ring against said polishing surface under a first pressing force; and ejecting pressurized fluid from openings in a plurality of areas in said holding surface of said top ring toward the workpiece held by said top ring, said pressurized fluid being selectively ejectable from said openings in said respective areas; and

polishing the workpiece in such a state that a pressing force applied to the workpiece by said pressurized fluid is variable in a central portion and an outer circumferential portion of the workpiece, respectively.]

[9. A method according to claim 8, further comprising the step of:

pressing a presser ring vertically movably disposed around said top ring against said polishing surface around the workpiece under a second pressing force which is determined based on said first pressing force.]

[10. A method according to claim 8, said second pressing force is determined on the basis of a pressure distribution on the workpiece caused by said pressurized fluid ejected from said openings in said respective areas.]

[11. A top ring for supporting the workpiece to be polished, for use in a polishing apparatus, comprising:

a holding surface for holding the workpiece; and

a plurality of openings, provided in said holding surface, from which pressurized fluid is ejected, a plurality of areas each having said openings being defined in said holding surface so that said pressurized fluid is selectively ejectable from said openings in said respective areas.]

12. A method of polishing a surface of a workpiece, comprising:

holding a workpiece by a top ring; and

pressing the workpiece against a polishing surface of a turntable to polish a surface of the workpiece so that an annular area of said workpiece is selectively pressed, wherein polishing pressures applied to said workpiece are controlled on the basis of pressures detected by pressure sensors.

13. A method according to claim 12, wherein said annular area of said workpiece is an outer circumferential portion of said workpiece.

14. A method according to claim 12, further comprising applying a pressure to a presser ring vertically movably disposed around said top ring for pressing and polishing surface.

15. A method according to claim 12, wherein each of said pressures applied to the workpiece and said presser ring is produced by air pressure.

16. A method of polishing a surface of a workpiece, comprising:

holding a workpiece by a top ring;

pressing the workpiece against a polishing surface of a turntable so that a polishing pressure applied to a central portion of the workpiece is different from a polishing pressure applied to an outer circumferential portion of the workpiece to polish a surface of the workpiece; and

applying a pressure which is independently variable to a presser ring vertically movably disposed around said top ring for pressing said polishing surface,

wherein said polishing pressure applied to the central portion of the workpiece and said polishing pressure applied to the outer circumferential portion of the workpiece as controlled on the basis of pressures detected by pressure sensors.

17. A method of polishing a surface of a workpiece, comprising:

holding a workpiece on an elastic pad attached to a lower surface of a top ring; and

pressing the workpiece against a polishing surface of a turntable to polish a surface of the workpiece by applying at least two pressures through said elastic pad to substantially concentric circular areas of the workpiece, respectively.

15

18. A method of polishing a surface of a workpiece, comprising:

holding a workpiece on an elastic pad attached to a lower surface of a top ring; and

pressing the workpiece against a polishing surface of a turntable to polish a surface of the workpiece by applying at least two pressures to two chambers configured above a central portion and an outer circumferential portion of the workpiece, respectively, and through said elastic pad.

19. A method of polishing a surface of a workpiece, comprising:

holding a workpiece by a top ring;

pressing the workpiece against a polishing surface of a turntable to polish a surface of the workpiece so that at least two pressures are applied to the workpiece and are different in a central portion and in an outer circumferential portion of the workpiece; and

applying a pressure to a presser ring vertically movably disposed around said top ring by air pressure for pressing said polishing surface,

wherein said at least two pressures are controlled on the basis of pressures detected by pressure sensors.

20. A method of polishing a surface of a workpiece, comprising:

holding a workpiece by a top ring;

applying air pressure to an interior of said top ring so that the polishing pressures applied to the workpiece are different at different radial portions of said workpiece; and

applying a pressure to a presser ring vertically movably disposed around said top ring by air pressure for pressing and polishing surface,

wherein said polishing pressures are controlled on the basis of pressures detected by pressure sensors.

21. A polishing apparatus for polishing a surface of a workpiece comprising:

a turntable having a polishing surface thereon;

a top ring supporting the workpiece to be polished to polish a surface of the workpiece on said polishing surface,

a presser ring vertically movably disposed around said top ring, said presser ring being movable with respect to said top ring; and

a pressing mechanism for providing polishing pressures on the workpiece by air pressure,

wherein said polishing pressures are different in a central portion and an outer circumferential portion of the workpiece, and

wherein said presser ring is pressed against said polishing surface under a variable pressure independently of said polishing pressures.

22. A polishing apparatus according to claim 21, wherein said pressing force has gradient so as to be higher or lower progressively from the central area to the outer circumferential area of the workpiece.

23. A polishing apparatus according to claim 21, wherein the pressure applied to a central portion of the workpiece is larger than the pressure applied to an outer circumferential portion of the workpiece.

24. A polishing apparatus according to claim 21, wherein the pressure applied to an outer circumferential portion of the workpiece is larger than the pressure applied to a central portion of the workpiece.

16

25. A polishing apparatus for polishing a surface of a workpiece comprising:

a turntable having a polishing surface thereon;

a top ring for supporting the workpiece to be polished on a holding surface of said top ring and

pressing the workpiece against said polishing surface;

a first pressing device for pressing said top ring against said polishing surface under a first pressing force;

a presser ring vertically movably disposed around said top ring;

a second pressing device for pressing said presser ring against said polishing surface under a second pressing force, said second pressing force being variable with respect to said first pressing force; and

a pressing mechanism for providing a third pressing force onto the workpiece, said third pressing force being different in a central portion and an outer circumferential portion of the workpiece,

wherein said third pressing force is controlled on the basis of pressures detected by pressure sensors.

26. A polishing apparatus according to claim 25, wherein said pressing force has gradient force so as to be higher or lower progressively from the central area to the outer circumferential area of the workpiece.

27. A polishing apparatus according to claim 25, wherein the pressure applied to a central portion of the workpiece is larger than the pressure applied to an outer circumferential portion of the workpiece.

28. A polishing apparatus according to claim 25, wherein the pressure applied to an outer circumferential portion of the workpiece is larger than the pressure applied to a central portion of the workpiece.

29. A polishing apparatus according to claim 25, wherein said pressing mechanism provides said third pressing force by air pressure.

30. A polishing apparatus according to claim 25, wherein said first pressing device and second pressing device provide said first and second forces by air pressure.

31. A polishing apparatus for polishing a surface of a workpiece comprising:

a turntable having a polishing surface thereon;

a top ring for supporting the workpiece to be polished on a holding surface of said top ring;

a pressing mechanism for pressing the workpiece against said polishing surface of said turntable so that a polishing pressure applied to a central portion of the workpiece is different from a polishing pressure applied to an outer circumferential portion of the workpiece to polish a surface of the workpiece; and

a presser ring vertically movably disposed around said top ring, said presser ring being movable with respect to said top ring, and pressed against said polishing surface by air pressure,

wherein said polishing pressure applied to said central portion and said polishing pressure applied to said outer circumferential portion are controlled on the basis of pressures detected by pressure sensors.

32. A workpiece carrier for holding a workpiece and pressing the workpiece against a polishing surface, and workpiece carrier comprising:

a top ring for supporting the workpiece to be polished; and

at least two pressurized chambers provided in said top ring and to which pressurized fluid is supplied, said at

17

least two pressurized chambers comprising a central circular chamber and an annular chamber located outside of said central circular chamber,
 said central circular chamber and said annular chamber being positionable over a central circular area and an annular area of the workpiece, respectively,
 wherein a first polishing pressure applied to the central circular area of the workpiece and a second polishing pressure applied to the annular area of the workpiece are created by said pressurized fluid supplied to said central circular chamber and said annular chamber, respectively,
 wherein said first polishing pressure and second polishing pressure are controlled on the basis of pressures detected by pressure sensors.

33. A polishing apparatus for polishing a surface of a workpiece, said polishing apparatus comprising:
 a turntable having a polishing surface thereon;
 a top ring for supporting the workpiece to be polished; and
 a pressing mechanism for pressing the workpiece against said polishing surface, said pressure mechanism being capable of applying a first polishing pressure to a central circular area of the workpiece and a second polishing pressure to a first annular area of the workpiece located outside of the central circular area, said first polishing pressure and said second polishing pressure being controllable independently of each other on the basis of pressures detected by pressure sensors.

34. The polishing apparatus is claimed in claim 33, wherein said pressing mechanism comprises at least two pressurized chambers to which pressurized fluid is supported, said at least two pressurized chambers comprising a central circular chamber and a first annular chamber located outside of said central circular chamber,
 wherein said central circular chamber and said first annular chamber are configured to correspond to the central circular area and the first annular area of the workpiece, respectively,
 wherein the first polishing pressure and the second polishing pressure can be created by the pressurized fluid being supplied to said central circular chamber and said first annular chamber, respectively.

35. The polishing apparatus as claimed in claim 34, wherein said first polishing pressure and said second polishing pressure are controllable independently of each other during polishing.

36. The polishing apparatus as claimed in claim 33, wherein said first polishing pressure and said second polishing pressure can be substantially uniformly applied in each of said areas of the workpiece.

37. The polishing apparatus as claimed in claim 33, wherein said first polishing pressure and said second polishing pressure are controllable by varying fluid pressure.

38. The polishing apparatus as claimed in claim 34, wherein said pressurized fluid comprises pressurized air.

39. The polishing apparatus as claimed in claim 34, further comprising a second annular chamber located outside of said first annular chamber and configured to correspond to a second annular area of the workpiece that is located outside of the first annular area of the workpiece, wherein a third polishing pressure can be applied to said second annular area and is created by pressurized fluid being supplied to said second annular chamber.

40. The polishing apparatus as claimed in claim 39, wherein the pressurized fluid supplied to said second annular chamber comprises pressurized air.

18

41. A polishing apparatus for polishing a surface of a workpiece, said polishing apparatus comprising:
 a turntable having a polishing surface thereon;
 a top ring for supporting the workpiece to be polished;
 three pressurized chambers provided in said top ring to which pressurized fluid is supplied, said three pressurized chambers comprising a central circular chamber, a first annular chamber located outside of said central circular chamber, and a third annular chamber located outside of said first annular chamber,
 wherein said pressurized chambers can be positioned above the workpiece so that a first polishing pressure can be applied to a central circular area of the workpiece, a second polishing pressure can be applied to a first annular area of the workpiece located outside of the central circular area, and a third polishing pressure can be applied to a second annular area of the workpiece located outside of the first annular area of the workpiece,
 wherein the first, second and third polishing pressures can be created by pressurizing fluid being supplied to said first central circular chamber, said annular chamber and said third annular chamber, respectively, and
 wherein at least one of said three pressurized chambers has an opening defined in a surface on which the workpiece is held.

42. A polishing apparatus for polishing a surface of a workpiece, said polishing apparatus comprising:
 a turntable having a polishing surface thereon;
 a top ring for supporting the workpiece to be polished;
 at least two pressurized chambers provided in said top ring to which pressurized fluid is supplied,
 said at least two pressurized chambers comprising a central circular chamber and an annular chamber located outside of said central circular chamber,
 wherein said central circular chamber and said annular chamber are configured so as to be positionable over a central circular area and an annular area of the workpiece, respectively,
 wherein a first polishing pressure can be applied to said central circular area of the workpiece and a second polishing pressure can be applied to the annular area of the workpiece, said first and second polishing pressures being created by said pressurized fluid being supplied to said central circular chamber and said first annular chamber, respectively; and
 a presser ring vertically movable with respect to said top ring, wherein said presser ring is adapted to be pressed against said polishing surface,
 wherein at least one of said at least two pressurized chambers has an opening defined in a surface on which the workpiece is held.

43. A method for polishing a surface of a workpiece, the method comprising:
 holding a workpiece by a top ring;
 pressurizing a central circular chamber in the top ring to apply a first pressure to a central circular area of the workpiece;
 pressurizing a first annular chamber in the top ring to apply a second pressure to a first annular area of the workpiece located outside of the central circular area of the workpiece;
 pressurizing a second annular chamber in the top ring to apply a third pressure to a second annular area of the

19

workpiece located outside of the first annular area of the workpiece; and
controlling the first pressure and the second pressure and the third pressure on the basis of pressures detected by pressure sensors.

44. A polishing apparatus for polishing a surface of a workpiece, comprising:

- a turntable having a polishing surface thereon;
- a top ring to support the workpiece to be polished on a holding surface of said top ring;
- a presser ring vertically movably disposed around said top ring;
- a mechanism to move said top ring vertically so that said top ring moves toward and away from said polishing surface;
- a pressing mechanism to provide a first pressing force onto the workpiece, said first pressing force being different in a central portion and an outer circumferential portion of the workpiece; and
- a pressing ticket to press and presser ring against said polishing surface under a second pressing force, said second pressing force being independently controllable with respect to said first pressing force,

wherein said first pressing force is controlled on the basis of pressures detected by pressure sensors.

45. A polishing apparatus for polishing a surface comprising:

- a turntable having a polishing surface thereon;
- a top ring for supporting the workpiece to be polished and pressing the workpiece against said polishing surface under a first pressing force, said top ring having a surface area facing downward to be directed toward the workpiece when the workpiece is held by said top ring;
- a pressurized fluid source for supplying pressurized fluid;
- a plurality of openings provided in said surface area of said top ring for ejecting said pressurized fluid supplied from said pressurized fluid source, a plurality of areas each having said openings being defined so that said pressurized fluid is selectively ejectable from said openings in said respective areas.

46. The polishing apparatus of claim 45, and further comprising a material disposed at said surface for pressing against the wafer.

47. The polishing apparatus of claim 46, wherein said material comprises an elastic pad.

48. The polishing of claim 47, wherein said elastic pad comprises through holes therein for communication with said plurality of openings in said surface of said top ring.

49. A polishing apparatus for polishing a surface of a workpiece comprising:

- a turntable having a polishing surface thereon;
- a pressurized fluid source;
- a top ring connected with said pressurized fluid source and having upper side and a lower side for facing and applying pressure to a workpiece to be polished;
- fluid openings on said lower side of said top ring body provided in a plurality of areas on said lower side and connected with said pressurized fluid source so as to be capable of selectively and independently providing a fluid pressure to said plurality of areas on said lower side.

50. The polishing apparatus of claim 49, and further comprising a material disposed at said lower side for pressing against the wafer.

51. The polishing apparatus of claim 50, wherein said material comprises an elastic pad.

52. The polishing apparatus of claim 51, wherein said elastic pad comprises through holes therein for communication with said plurality of openings in said lower side of said top ring.

20

53. The polishing apparatus for polishing a surface of a workpiece comprising:

- a turntable having a polishing surface thereon;
- a top ring for supporting the workpiece to be polished and pressing the workpiece against said polishing surface, said top ring comprising:
- a holding surface for holding the workpiece;
- a plurality of openings provided in said holding surface; and
- a plurality of chambers connected to a pressurized fluid source, each of said chambers is communicated with at least one of said openings so that said holding surface is divided to a plurality of areas, each of which related to each of said chambers respectively.

54. An apparatus according to claim 53, wherein said plurality of areas comprises concentric annular areas.

55. An apparatus according to claim 53, further comprising:

- a plurality of regulators through which said chambers are connected to said pressurized fluid source so that pressures supplied to said chambers are independently controllable.

56. An apparatus according to claim 53, further comprising:

- a presser ring disposed around and holding surface; and
- a pressing device for pressing said pressing ring against said polishing surface by a pressure of a pressurized fluid.

57. A workpiece supporting and pressing apparatus comprising:

- a holding surface made of an elastic material for holding a workpiece to be polished;
- a circular chamber positioned above a central area of said holding surface;
- a first annular chamber positioned above an annular area surrounding said central area of said holding surface; and
- a plurality of openings provided in said holding surface and communicated with each of said circular chamber and said first annular chamber respectively;

wherein each pressure of said circular chamber and said first annular chamber is independently controllable.

58. A workpiece supporting and pressing apparatus according to claim 57, further comprising:

- a second annular chamber positioned above an annular area surrounding said annular area of said holding surface;

wherein some of said plurality of openings are communicated with said second annular chamber, and pressure of said annular chamber is independently controllable.

59. A workpiece supporting and pressing apparatus comprising:

- a holding surface made of an elastic material for holding a workpiece to be polished;
- a first chamber positioned above said holding surface;
- a second chamber positioned above said holding surface;
- a first group of openings provided in said holding surface and communicated with said first chamber; and
- a second group of openings provided in said holding surface and communicated with said second chamber.

UNITED STATES PATENT AND TRADEMARK OFFICE
CERTIFICATE OF CORRECTION

PATENT NO. : RE 38,854 E
DATED : October 25, 2005
INVENTOR(S) : Masamichi Nakashiba et al.

Page 1 of 1

It is certified that error appears in the above-identified patent and that said Letters Patent is hereby corrected as shown below:

Column 16,

Line 62, change "and" to -- said --;

Column 17,

Line 13, after "and" insert -- said --;

Line 30, change "is" to -- as --;

Column 18,

Line 21, change "pressurizing" to -- pressurized --;

Column 19,

Line 20, change "a pressing ticket to press and" to -- a pressing device to press said --;

Line 26, after "surface" insert -- of a workpiece --;

Line 43, after "polishing" insert -- apparatus --;

Line 51, after "having" insert -- an --;

Line 60, change "comprises" to -- comprising --;

Column 20,

Line 1, change "The" to -- A --;

Line 26, change "and" first occurrence to -- said --; and

Line 27, change "pressing" third occurrence to -- presser --.

Signed and Sealed this

Seventh Day of March, 2006

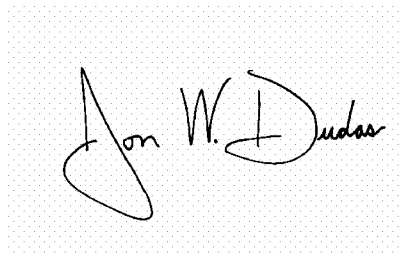
A handwritten signature in black ink on a light gray dotted background. The signature reads "Jon W. Dudas" in a cursive, stylized script.

JON W. DUDAS

Director of the United States Patent and Trademark Office