

W. S. COOPER.

Improvement in Valves for Water-Closets.

No. 132,523.

Patented Oct. 29, 1872.

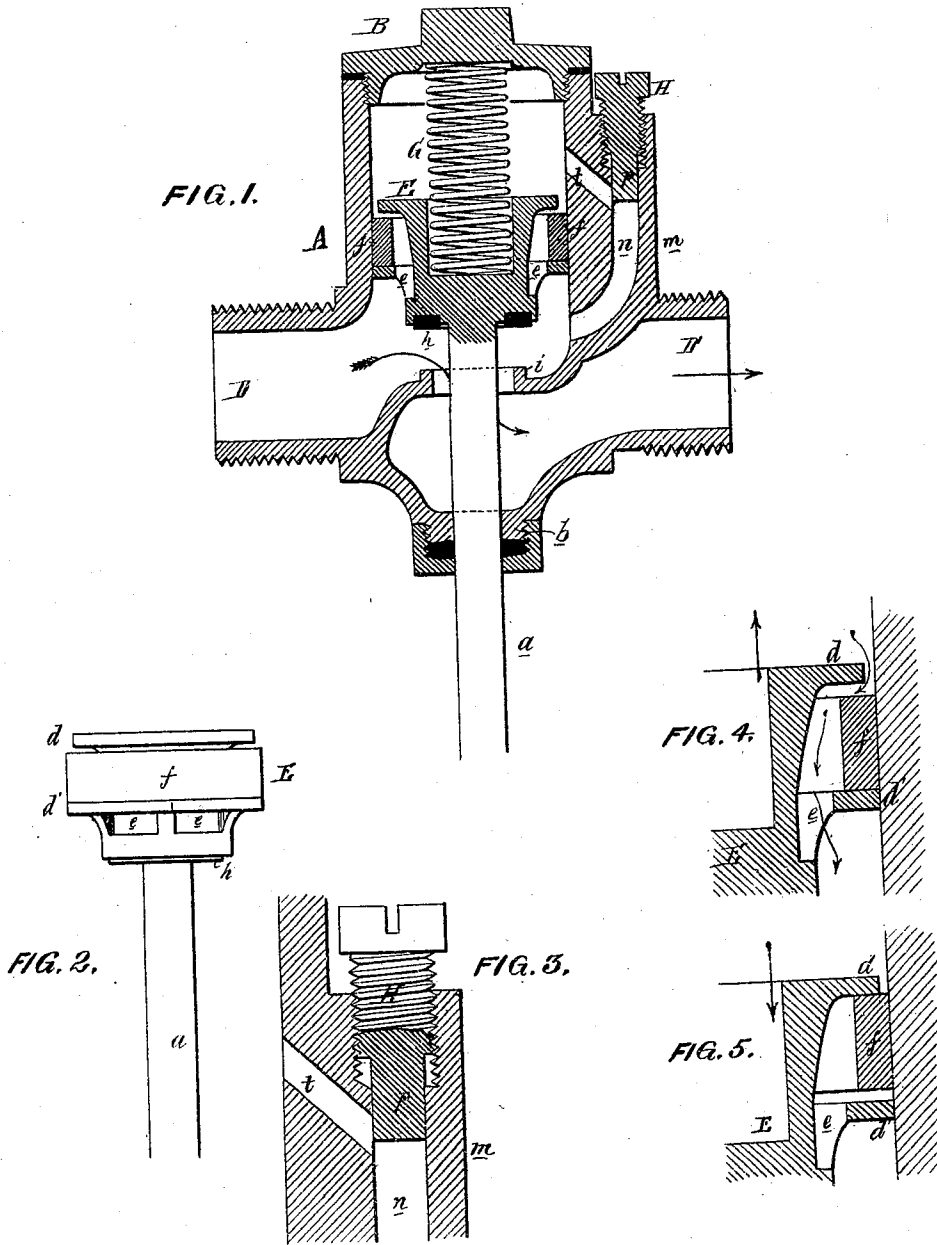

Witnesses. *Harry Smith*
John Parker

William S. Cooper
by his Atty.
Howson and Son

UNITED STATES PATENT OFFICE.

WILLIAM S. COOPER, OF PHILADELPHIA, PENNSYLVANIA.

IMPROVEMENT IN VALVES FOR WATER-CLOSETS.

Specification forming part of Letters Patent No. 132,523, dated October 29, 1872.

To all whom it may concern:

Be it known that I, WILLIAM S. COOPER, of Philadelphia, Pennsylvania, have invented certain Improvements in Valve-Cocks for Water-Closets, of which the following is a specification:

My invention relates to that class of valve-cocks which are used in connection with water closets with the view of admitting water to the same on pulling a handle, and permitting the water to flow into the basin for a limited time after the handle is released; and my improvement consists of a valve-piston having a valvular packing and certain openings adapted to the casing of the cock, all in a manner too fully explained hereafter to need preliminary description, so that the said piston-valve will be free to be raised easily by the handle, but will be in a condition to be controlled in its descent when released by the water admitted to the space above it. My invention further consists of the combination of the said piston-valve with the casing and with certain passages, and an adjusting-screw for regulating the flow of water which controls the descent of the piston-valve, all as fully explained hereafter.

Figure 1 is a vertical section of my improved valve-cock; Fig. 2, an exterior view of the improved piston-valve; Fig. 3, a sectional view of the device for regulating the descent of the piston-valve; and Figs. 4 and 5, sectional views illustrating the action of the valvular packing.

Figs. 1 and 2 are full-sized views, and Figs. 3, 4, and 5 are double the actual size.

A is the cylindrical casing of the valve-cock, and this casing is provided with a screw-cover, B, and an inlet-branch, D, and outlet-branch D'. E is the piston-valve, the stem *a* of which projects downward through a stuffing-box, *b*, at the bottom of the casing, the stem being in a position to be operated by the usual appliances connected with the pull-handle of the water-closet. The piston-valve has two flanges, *d* and *d'*, the annular space between which communicates at all times with the space in the casing beneath the piston, and also, under the circumstances described hereafter, with the space above the piston. As the upper flange *d* is somewhat less in diameter than the interior of the casing A, a ring, *f*, of rubber or other equivalent material, occupies a position

and has a limited vertical play between the two flanges of the piston, the ring serving the twofold purpose of a packing for the piston and a valve, as explained hereafter. It is not absolutely necessary that the lower flange *d'* should be continuous, as it may, if desired for convenience in casting, consist merely of a series of radial arms of sufficient width to properly support and retain the ring *f*. Into an annular recess in the under side of the piston is packed a ring, *h*, of rubber, which, when the piston is depressed, bears on the seat *i* and thus prevents the passage of the water from the inlet to the outlet branch of the casing. A light spiral spring, G, intervenes between the cover and the valve-spindle, as shown in Fig. 1. On one side of the cylindrical casing A there is a projection, *m*, in which a passage, *n*, communicating below at all times with the space in the casing beneath the piston-valve, and into the upper end of this passage fits the plain portion *p* of the screw H, directly opposite which is a passage, *t*, forming a communication between the passage *n* and the space in the casing above the piston-valve E, (Figs. 1 and 3.) By adjusting the screw, the plain portion *p* of the same can be raised or lowered so as to expose or partially close the passage *t*, and thus form a communication of greater or less area between the same and the passage *n*. On raising the piston-valve the ring *f*, owing to its friction against the interior of the casing, has a tendency to bear on the lower flange *d'*, as shown in Fig. 4, thereby permitting water above the piston-valve to pass downward between the flange *d* and the interior of the casing, and through the opening *e* to the space beneath the piston-valve; but the moment the latter, after being elevated, is released, the tendency of the spring is to give a sudden downward impulse to the piston-valve, and this, owing to the friction of the ring against the casing, will cause the upper edge of the ring to bind hard against the upper flange *d*, as shown in Fig. 5, and close the communication between the space above and the space below the piston, and the latter is consequently in a condition to be acted on by the water which flows from below through the passage *n* to the space above the piston, the rapidity with which the water takes this course being dependent upon

the extent to which the passage *t* has been exposed by the adjustment of the screw *H*, and consequently the time taken for the piston to descend to its seat and cut off the flow of water is dependent upon the same adjustment of the screw, and this adjustment is made in accordance with the time during which it is desirable for the water to escape into the basin of the water-closet. It will now be seen that the ring *f* performs the function both of a valve and packing.

I claim as my invention—

1. The piston-valve *E* with its movable valvular packing *f* and openings *ee*, the whole

being adapted to the interior of the casing *A*, substantially as set forth.

2. The combination of the said piston-valve and casing with the passages *n* and *t*, and the screw *H* for regulating the flow of water through the said passages.

In testimony whereof I have signed my name to this specification in the presence of two subscribing witnesses.

WM. S. COOPER.

Witnesses:

WM. A. STEEL,
HARRY SMITH.